



STAUFF Filtration Technology offers a complete range of filtration products and services. This will provide the system designer or user with the highest level of contamination control demanded by today's most sophisticated applications.

STAUFF Filtration Technology Products include Pressure Filters, Return -Line Filters, Elements, Spin-On Filters, Suction Strainers and Filler Breathers for various hydraulic, lubrication and fuel oils.

STAUFF has the technical expertise to provide superior filter element designs for the STAUFF original filter housings and also for the interchange element market. STAUFF manufactures more than 10000 different elements.

Many of these are designed to fit into filter housings produced by other companies while maintaining or surpassing the original performance.

A well-stocked warehouse guarantees the possibility of short-term arrangements without their own storage. Therefore, we can react flexible for your specific needs.

The "STAUFF Contamination Control Program" comprised the diagnostic services including fluid sampling and laser particle counting products for monitoring the system contamination level. In addition STAUFF offers a range of software solutions for element interchange and filter calculation. All products are subject to the audits in reference to international standards. This ensures a consistently high standard of quality.

Please do not hesitate to contact STAUFF for further details.

www.stauff.com





C

Filtration Technology

Index	C2
Filtration Guideline	C6
Pressure Filters	C18
Return Line Filters	C47
Spin-On Filters	C118
Offline- and Bypass Filters	C145
Mobile Filter Units	C172







Filtration Guideline









Pressure Filters

Introduction	C6	Overview Types SF / SF-TM / SF-SM / SFA		C18
Filtration - Why?	C7	 High Pressure Filters Max. 420 bar / 6000 PSI Max. 1320 l/min / 300 US GPM Technical Data / Dimensions High Pressure Filter - Order Code Filter Elements - Order Code	SF	
Contamination	C7		SF SE	C19 C22 C22
STAUFF Filter Components	C9	 High Pressure Filters Max. 315 bar / 4560 PSI Max. 1320 l/min / 300 US GPM Technical Data / Dimensions High Pressure Filter - Order Code Filter Elements - Order Code	SF-TM	
Test Standards and Oil Purity	C10		SF-TM SE	C23 C26 C26
Short & Curt: Filter Rating	C11	 High Pressure Filters Max. 315 bar / 4560 PSI Max. 1320 l/min / 300 US GPM Technical Data / Dimensions High Pressure Filter - Order Code Filter Elements - Order Code	SF-SM	
β-Value and Separations Efficiency	C11			C27 C30 C30
Filtration Terminology	C12		SF-SM SE	
Choice of Filters / Examples of Calculation	C14	 Medium Pressure Filters Max. 160 bar / 2320 PSI Max. 240 l/min / 70 US GPM Technical Data / Dimensions Medium Pressure Filter - Order Code Filter Elements - Order Code	SFA	
Filter Selection Software	C15		SFA SE	C31 C34 C34
STAUFF Replacement Filter Elements	C16	Valves Technical Data Order Code	HV-0 / HV-B / HV-R / HV-N / HV-M	C35
		Clogging Indicators Technical Data Order Code Dimensions	HI	C36
		 Filter Elements Technical Data Order Code	SE	C37
		Flow Characteristics Types SF / SF-TM / SF-SM / SFA		C38
		 Medium Pressure Filters Max. 110 bar / 1600 PSI Max. 90 l/min / 25 US GPM Technical Data / Dimensions Medium Pressure Filter - Order Code Filter Elements - Order Code	SMPF SMPF SME	C41 C44 C44
		Clogging Indicators Visual Clogging Indicator Visual-Electrical Clogging Indicator Order Code	HIM-V HIM-VE	C45
		Flow Characteristics Type SMPF		C46

Return Line Filters





















Return Line Filter

	Return Line Filters Max. 14 bar / 200 PSI Max. 7000 l/min / 1850 US GPM Technical Data / Dimensions Return Line Filter - Order Code Filter Elements - Order Code	SRFL-S / SRFL-D	C47 C58 C58
	Filter Elements Description Order Code	RE	C59
	Differential Pressure Switch with Visual Gauge Indicator		C59
	Flow Characteristics Type SRFL-S / D		C60
	Return Line Filters Max. 16 bar / 232 PSI Max. 500 l/min / 130 US GPM Technical Data / Dimensions Return Line Filter - Order Code Filter Elements - Order Code	RF	C61 C64 C64
	Options - Clogging Indicators Visual Clogging Indicator Electrical Clogging Switch Filter Bowl with Threaded Connection Leakage Oil Connection Filter Bowl with Threaded Connection and Diffuser		C65
	Flow Characteristics Type RF		C66
	Return Line Filters Max. 25 bar / 365 PSI Max. 30 l/min / 110 US GPM Technical Data / Dimensions Return Line Filter - Order Code Filter Elements - Order Code	RFA	C69 C72 C72
	Options - Clogging Indicators Visual Clogging Indicator Electrical Clogging Switch Filter Bowl with Threaded Connection Leakage Oil Connection Filter Bowl with Threaded Connection and Diffuser		C73
	Flow Characteristics Type RFA		C74
	Return Line Filters Max. 10 bar / 145 PSI Max. 185 l/min / 52 US GPM Technical Data / Dimensions Return Line Filter - Order Code Filter Elements - Order Code Air Filter Elements - Order Code	RFB	C75 C78 C78 C78
	Options - Clogging Indicators Visual Clogging Indicator Electrical Clogging Switch Air Filter Element Filter Bowl with Threaded Connection		C79
	Flow Characteristics Type RFB		C80

	Return Line Filter Max. 25 bar / 365 PSI Max. 1135 l/min / 300 US GPM Technical Data / Dimensions Return Line Filter - Order Code Filter Elements - Order Code	RFS	C81 C84 C84
	Options - Clogging Indicators Visual Clogging Indicator Electrical Clogging Switch		C85
	Replacement Filter Elements Description Order Code	RE	C85
	Flow Characteristics Type RFB		C86
	Return Line Filters Max. 34,5 bar / 500 PSI Max. 1135 l/min / 300 US GPM Technical Data / Dimensions Return Line Filter - Order Code Filter Elements - Order Code	RIF300	C89 C91 C91
	Clogging Indicators Visual Clogging Indicator Visual-Electrical Clogging Indicator Order Code		C92
	Flow Characteristics Type RIF300		C93
	Return Line Filters Max. 34,5 bar / 500 PSI Max. 1135 l/min / 300 US GPM Technical Data / Dimensions Return Line Filter - Order Code Filter Elements - Order Code	RTF10/25	C95 C98 C98
	Return Line Filters Max. 34,5 bar / 500 PSI Max. 1135 l/min / 300 US GPM Technical Data / Dimensions Return Line Filter - Order Code Filter Elements - Order Code	RTF20	C99 C102 C102
	Return Line Filters Max. 6,9 bar / 100 PSI Max. 378 l/min / 100 US GPM Technical Data / Dimensions Return Line Filter - Order Code Filter Elements - Order Code	RTF40	C103 C106 C106
	Return Line Filters Max. 6,9 bar / 100 PSI Max. 379 l/min / 100 US GPM Technical Data / Dimensions Return Line Filter - Order Code Filter Elements - Order Code	RTF50	C107 C110 C110
	Return Line Filters Max. 10 bar / 145 PSI Max. 500 l/min / 132 GPM Technical Data / Dimensions Return Line Filter - Order Code Filter Elements - Order Code	RTF-N	C111 C114 C114
	Flow Characteristics Type RTF		C115
	Clogging Indicators Visual Clogging Indicator Electrical Clogging Indicator Order Code		C117

Spin-On Filters

Spin-On-Filter

Introduction Technical Data Private Labelling		C118		Tank Top Spin-On Filter Heads Max. 7 bar / 100 PSI Max. 75 l/min / 20 US GPM Technical Data / Dimensions Order Code	SSFT-12B	C131
Quick Reference Guide Spin-On Filter Heads Spin-On Filter Elements		C119				
 Spin-On Filter Heads Max. 14 bar / 200 PSI Max. 26 l/min / 7 US GPM Technical Data / Dimensions Order Code	SLF-02 / 03 / 04	C120		Tank Top Spin-On Filter Heads Max. 7 bar / 100 PSI Max. 75 l/min / 20 US GPM Technical Data / Dimensions Order Code	SSFT-12	C132
 Spin-On Filter Heads Max. 14 bar / 200 PSI Max. 90 l/min / 25 US GPM Technical Data / Dimensions Order Code	SAF-05 / 06 / 07 / 11	C121		Tank Top Spin-On Filter Heads Max. 7 bar / 100 PSI Max. 200 l/min / 53 US GPM Technical Data / Dimensions Order Code	SSFT-20B	C133
 Spin-On Filter Heads Max. 14 bar / 200 PSI Max. 128 l/min / 34 US GPM Technical Data / Dimensions Order Code	SAF-10 / 13	C122		Tank Top Spin-On Filter Heads Max. 7 bar / 100 PSI Max. 200 l/min / 53 US GPM Technical Data / Dimensions Order Code	SSFT-20	C134
 Spin-On Filter Heads Max. 12 bar / 174 PSI Max. 90 l/min / 25 US GPM Technical Data / Dimensions Order Code	SSF-12	C123		Spin-On Filter Elements Technical Data Dimensions	SFC-35 / 36 SFCT-35 / 36	C135
 Spin-On Filter Heads Max. 12 bar / 174 PSI Max. 225 l/min / 60 US GPM Technical Data / Dimensions Order Code	SSF-20L	C124		Spin-On Filter Elements Technical Data Dimensions	SFC-57 / 58 SFCT-57 / 58	C136
 Spin-On Filter Heads Max. 14 bar / 200 PSI Max. 225 l/min / 60 US GPM Technical Data / Dimensions Order Code	SSF-100 / 120 / 120L / 130 / 160	C125		Spin-On Filter Elements Technical Data Dimensions	SF63	C137
 Spin-On Filter Heads Max. 14 bar / 200 PSI Max. 300 l/min / 80 US GPM Technical Data / Dimensions Order Code	SSF-150 / 180	C126		Spin-On Filter Elements Technical Data Dimensions	SF65	C138
 Double Spin-On Filter Heads Max. 12 bar / 174 PSI Max. 454 l/min / 120 US GPM Technical Data / Dimensions Order Code	SSF-24B	C127		Spin-On Filter Elements Technical Data Dimensions	SF67	C139
 Double Spin-On Filter Heads Max. 12 bar / 174 PSI Max. 454 l/min / 120 US GPM Technical Data / Dimensions Order Code	SSF-24N / 24S	C128		Flow Characteristics	SFC/SFCT-35 / 36 SFC/SFCT-57 / 58 SF63	C140
 Double Spin-On Filter Heads Max. 12 bar / 174 PSI Max. 454 l/min / 120 US GPM Technical Data / Dimensions Order Code	SSF-25B	C129		Flow Characteristics	SF65	C141
 Double Spin-On Filter Heads Max. 12 bar / 174 PSI Max. 454 l/min / 120 US GPM Technical Data / Dimensions Order Code	SSF-25	C130		Clogging Indicators Technical Data	SF67	C142
					SIS / GV / SIM / CI SIE-NO/NC / EPS/EVS	C143

Offline- and Bypass Filters

Mobile Filter Units

Overview		C145
Description		
Technical Data		
STAUFF System		C146
 Off-Line Filters	OLS	
Overview		C147
Dimensions		C148
Technical Data		
Off-Line Filter - Order Code	OLS	C152
Filter Elements - Order Code	SRM	
 Water Absorbing Off-Line Filters	OLSW	
Overview		C153
Dimensions		C154
Technical Data		
Water Absorbing Off-Line Filter- Order Code	OLS	C156
Filter Elements - Order Code	SRM	
Pre-Filter Elements - Order Code	SF	
 Heated Off-Line Filters	OLSH	
Overview		C157
Dimensions		C158
Technical Data		
Heated Off-Line Filter - Order Code	OLSH	C160
Filter Elements - Order Code	SRM	
 Bypass Filters	BPS	
Overview		C161
Dimensions		C162
Technical Data		
Bypass Filter - Order Code	BPS	C163
Filter Elements - Order Code	SRM	
Mounting Options		C164
Hydraulic Symbols / Flow Characteristics		C165
 Bypass Lube-Oil Filter	BPLS	
Overview		C166
Dimensions		
Technical Data		
Bypass Lube-Oil Filter - Order Code	BPLS	C167
Filter Elements - Order Code	SRM	
 Mini Water Vac	SMWV	
Overview		C168
Dimensions		
Technical Data		
Mini Water Vac - Order Code	SMWV	C169
 Replacement Filter Elements	SRM	
Description		C170
Technical Data		C171



Mobile Filter Units
Overview

SMFS / SCFC / SPFC **C172**





Introduction

STAUFF Filtration Technology offers two publications with knowledge and expertise about contamination in hydraulic fluids, filter types and assistance for selecting the right filter for the applications:

A. The compact "Filtration Guideline"

Please have a look at the following pages.

B. SCCP – STAUFF Contamination Control Program

A comprehensive guideline (only available in English language)



Multipass Test Bench



Selection of STAUFF Replacement Filter Elements

Filtration - Why?

Good hydraulic filtration is gaining more and more importance in the use of hydraulic systems.

Reducing contamination in the hydraulic system will reduce the wear of the components and thus extend the service life of the machine. This will prevent production downtime and lower the overall production costs.

Right from the beginning, there is contamination in a new hydraulic system, which reduces the service life of the system and its components such as valves and cylinders without any or with inadequate filtration.

This built-in dirt is created during the manufacturing of the components and mainly consists of coarse particles.

In addition to the contamination that arises during operation of the system, e.g. abrasive wear, dirt particles can also get into the system when it is filled with hydraulic oil. This is called ingress contamination.

Choosing the right filter contributes significantly to prevent the dangers mentioned above thereby ensuring efficient operation even after many years.

Reduction of Contamination

- Extension of service life
- Extension of maintenance intervals
- Reduction of machine downtime
- Reduction of environmental pollution

► Cost savings for the user

Contamination

Particle Sizes (Selection)

- 100 µm table salt, fine sand
- 75 µm diameter of a human hair
- 60 µm flower pollen
- 50 µm fog
- **30 µm (from approx.) resolution of the human eye**
- 15 µm fine particles
- 7 µm red blood cells
- 2 µm bacteria
- 1 µm layer of lubricating film (for comparison)

Type of Contamination

The most frequent ones are:

- Solid particles
- Free and dissolved water
- Non-dissolved air

A majority of the contamination can be removed with filtration.

Origin of Contamination

The main cause of failures and downtimes is dirt in the hydraulic system.

Failure analysis indicate that 70% of the failures are caused by faults in the hydraulic system. 90% of them are caused by impurities in the hydraulic oil.

Sources of External Contamination

- Filling and refilling the hydraulic tank
- Inadequately dimensioned breathers
- Damaged tank seals
- Replacement of hydraulic lines and components (pumps, cylinders)
- Impurities in the air

Types of Internal Contamination

- Contamination on/in the components caused by the manufacturing process (e.g. chips)
- Contamination on the components caused by the installation of the components

Sources of Internal Contamination

- Disintegration of particles from high pressure changes and tension on the surface of hydraulic components (e.g. cavitation)
- Material erosion that occurs at places in the hydraulic units due to the impact of pressurised liquid at high speeds (erosion wear)

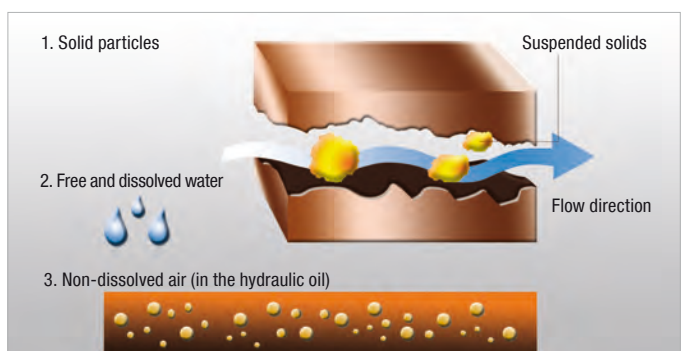
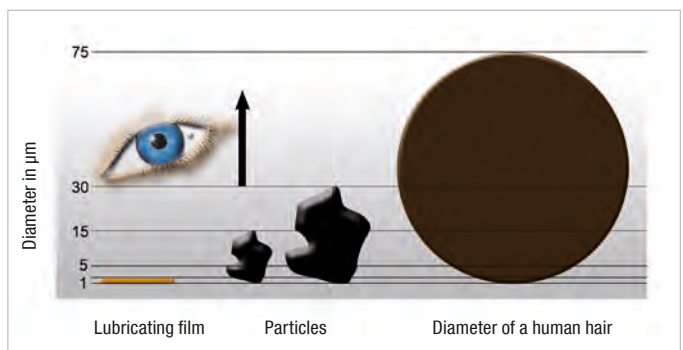



STAUFF Laser Particle Counter
LasPaC-II and Bottle Sampler

Selection of Components within the Hydraulic Circuit

- 1 Oil drum
- 2 STAUFF Mobile Filter-System SMFS-U
- 3 STAUFF Metal Filler Breather SMBB
- 4 STAUFF Return-Line Filter RF
- 5 STAUFF Diffusor SRV
- 6 STAUFF Suction Strainer SUS
- 7 STAUFF Pressure Filter SF
- 8 STAUFF Desiccant Air Breather SDB
- 9 STAUFF Plastic Filler Breather SPB
- 10 STAUFF Off-Line Filter OLS
- 11 STAUFF Level Gauge SNA

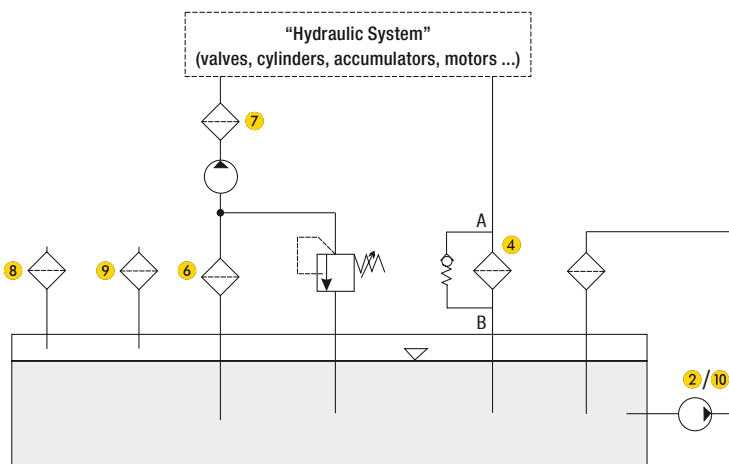
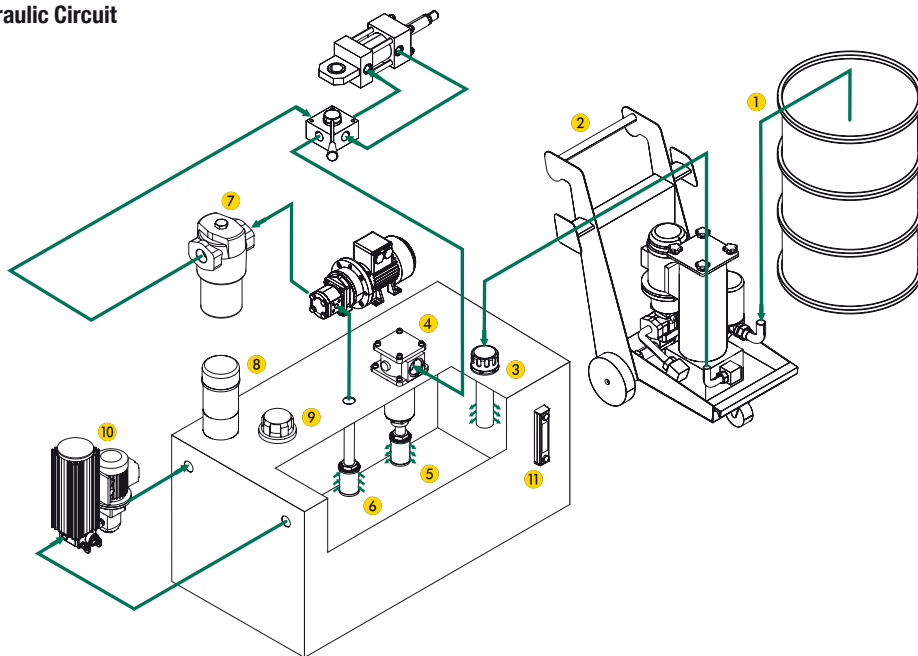

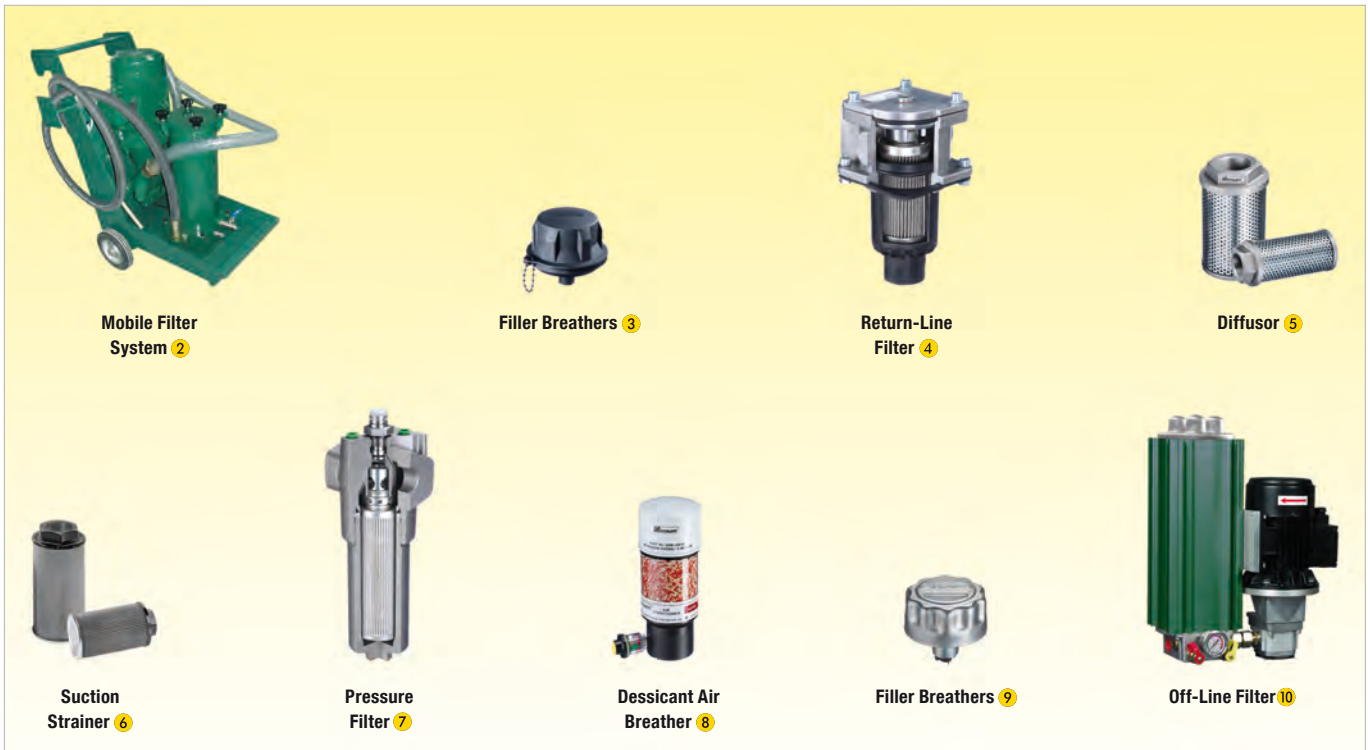

STAUFF Filter Components

Pressure Filters 7 are placed behind the pump and clean the hydraulic oil before it flows through down-stream components like valves, cylinders and so on. The main reason for pressure filtration is the protection of downstream, sensitive components.

Eroded particles from the pump are immediately filtered out of the hydraulic oil. Besides working as a protection filter, pressure filters also help to maintain the required purity class.

Because it is placed right behind the pump, a Pressure Filter has to withstand the maximum system pressure. The filter element in the pressure filter also has to withstand the loads and is more intricately constructed, for example as a Return-Line Filters element.

Return-Line Filters 4 are installed in the return line, on top of or within the oil tank. They filter the hydraulic oil before it flows back into the reservoir. This ensures that contamination arising in the components does not get into the tank. Return-Line Filters maintain the targeted purity class like pressure filters. However, because of their arrangement, they do not fulfil the additional function of a protection filter. In contrast to a pressure filter, it only has to withstand low pressure levels.

Diffusers 5 are used in combination with Return-Line Filters and ensure that the returning oil flow is settled before it reaches the oil tank thereby preventing foaming and re-suspension of deposited dirt.

The job of **Suction Strainers 6** is mainly to provide functional protection of the downstream pumps in the circulation. Suction Strainers always have to be provided if the risk of pump damage from coarse impurities is particularly high. This risk exists if impurities are collected in the tank and if they can't be filtered out afterwards. Suction Strainers are coarse filter elements with a micron rating that is usually bigger than 100 µm.

Filler Breathers 3/9 are mounted on the oil tank and prevent the entry of dirt from the surroundings during tank breathing. They should be chosen with a filter unit that is similar to the working filter (Pressure Filter, Return-Line Filter).

The replacement cycles of filter inserts is highly dependent on the surrounding conditions of the hydraulic system.

Another variant of the breather is the **Desiccant Air Breather 8**. The additional function of this filter is dehumidification of the inflowing air with a special silicate gel.

Off-Line / Bypass Filters 10 are not part of the main hydraulic system. They are supplementary to achieve the best possible filtration results. Because of the high efficiency of the Off-Line / Bypass Filters, purity levels are reached that cannot be achieved with conventional main filter systems.

Off-Line Filters work with an integrated motor/pump unit that draws in the fluid from the system, filters it and then feeds it back into the tank. Because the offline filter is independent from the hydraulic main circuit, i.e. it can still be operated if the hydraulic system is switched off, it is used in practice for continuous cleaning of the tank.

Bypass Filters on the other hand use the existing system pressure to draw a small volumetric flow out of the hydraulic system for filtration. They are only active while the unit is in operation.

Another mobile variant of the bypass filter is the **Mobile Filter System 2**.

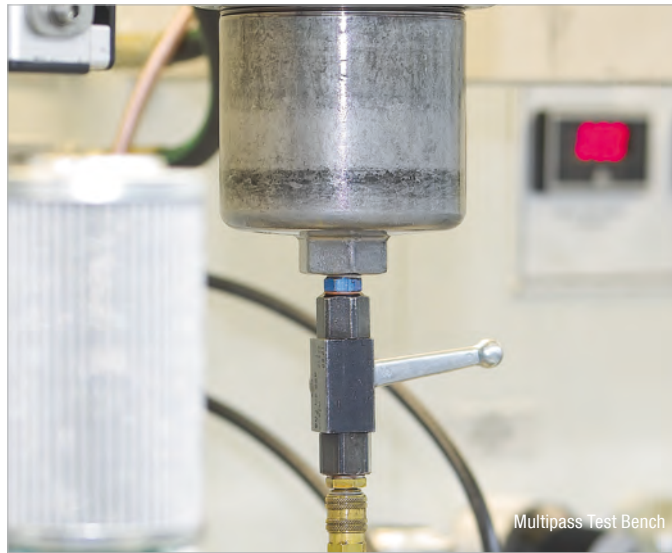
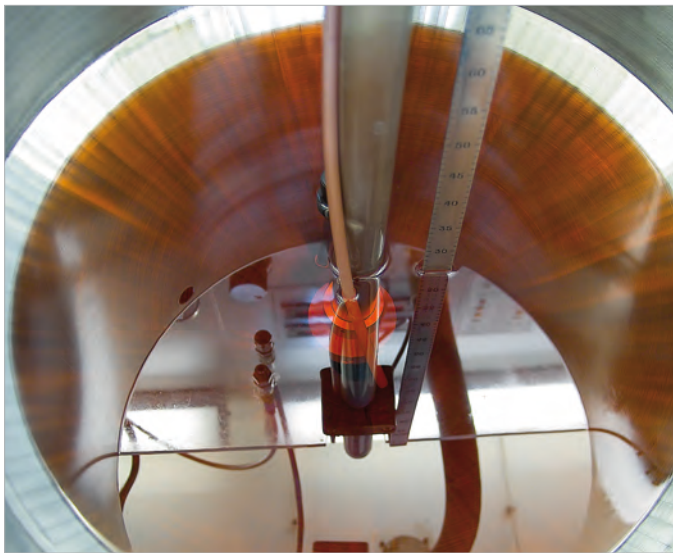

Multipass Test Bench

Test Standards and Oil Purity

Definition of the Required Micron Rating

Essentially, the components found in the hydraulic system determine the micron rating of the filtration system.

To guarantee a reliable mode of operation over the years, it is mandatory to maintain the optimum oil purity class for specific components.

The most sensitive component determines the choice of filter material and micron rating.

To determine the oil purity according to ISO 4406 (1999), a laser particle counter is used to count particles that are $>4 \mu\text{m}_{(c)}$, $>6 \mu\text{m}_{(c)}$ and $>14 \mu\text{m}_{(c)}$ in 100 ml of hydraulic oil. The number of particles is then assigned a classification number (e.g. 20/18/15) that then corresponds to the ISO purity class. Please note here that the number of particles doubles for the next higher class. The cleanliness level that has to be achieved is an important criterion for choosing the right filtration system.

STAUFF Filter Elements are Subject to the Following Test Methods

- ISO 2941 Collapse and burst resistance
- ISO 2942 Verification of fabrication integrity (bubble point test)
- ISO 2943 Compatibility with hydraulic media
- ISO 3723 End load test
- ISO 3724 Flow fatigue characteristics
- ISO 3968 Flow characteristics
- ISO 16889 Filtration performance test (multi-pass method)

Number of particles in 100 ml fluid		Classification numbers ISO 4406 (1999)		
More than	Less than	$> 4 \mu\text{m}_{(c)}$	$> 6 \mu\text{m}_{(c)}$	$> 14 \mu\text{m}_{(c)}$
8000000	16000000	24	24	24
4000000	8000000	23	23	23
2000000	4000000	22	22	22
1000000	2000000	21	21	21
500000	1000000	20	20	20
250000	500000	19	19	19
130000	250000	18	18	18
64000	130000	17	17	17
32000	64000	16	16	16
16000	32000	15	15	15
8000	16000	14	14	14
4000	8000	13	13	13
2000	4000	12	12	12



STAUFF Laser Particle Counter LasPaC-II and Bottle Sampler

Short & Curt: Filter Rating

(For exact recommendation see SCCP - STAUFF Contamination Control Program see page C15.)

Type	Component	ISO 4406 Code	Recommended Filter Rating
Pump	Piston Pump (Slow Speed, Inline)	22/20/16	20 µm
	Gear Pump	19/17/15	20 µm
	Vane Pump	18/16/14	5 µm
	Piston Pump (High Speed, Variable)	17/15/13	5 µm
Motor	Gear Motor	20/18/15	20 µm
	Vane Motor	19/17/14	10 µm
	Radial Piston Motor	19/17/13	10 µm
	Axial Piston Motor	18/16/13	5 µm
Valve	Directional Valves (Solenoid)	20/18/15	20 µm
	Check Valves	20/18/15	20 µm
	Logic Valves	20/18/15	20 µm
	Cartridge Valves	20/18/15	20 µm
	Pressure Control Valves (Modulating)	19/17/14	10 µm
	Flow Control Valves	19/17/14	10 µm
	Standard Hydraulic <100 bar / <1450 PSI	19/17/14	10 µm
	Proportional Valves	18/16/13	5 µm
	Servo Valves <210 bar / <3045 PSI	16/14/11	3 µm
Servo Valves >210 bar / >3045 PSI	15/13/10	3 µm	
Actuator	Cylinder	20/18/15	20 µm

β-Value and Separations Efficiency

To select filtration that meet the requirements, performance characteristics like the filter fineness, the filtration efficiency, the dirt-hold capacity and the pressure loss has to be observed.

 The β-value as per ISO 16889 is the relevant characteristic value for filtration efficiency. The β-value is the ratio of particles before (N_{up x}) and after (N_{down x}) the filter related to a specific particle size x.

$$\beta_x = \frac{N_{up\ x}}{N_{down\ x}}$$

 β₁₀ > 200 means that of 1000 particles that are 10 µm in size, only five particles can pass through the filter. 995 particles will be trapped by the filter element.

Popular filters with inorganic glass fibre medium have to achieve a β-value of at least 200 in order to meet the demands placed on hydraulic filtration today.

The filtration efficiency, also called the retention rate, is directly related to the β-value and is calculated as follows:

$$E = \frac{(\beta_x - 1)}{\beta_x}$$

 β₁₀ > 200 corresponds to filtration efficiency of 99,5%.

Comparison of the β-Value and Efficiency E (each related to a defined Particle Size)

β-value	Filtration Efficiency E
1	0,00 %
2	50,00 %
10	90,00 %
25	96,00 %
50	98,00 %
75	98,67 %
100	99,00 %
200	99,50 %
1000	99,90 %
9999	99,99 %

 The **dirt-hold capacity** (DHC) shows how much solid dirt a filter element can hold before it has to be replaced. The dirt-hold capacity is therefore the most important parameter in the filter service life.

 The **differential pressure** (Δp) is another important criterion for the configuration of the filter. Ensure that the size of the filter element is chosen according to the calculation guideline by STAUFF.

To guarantee optimum filtration, the β-value, the dirt-hold capacity (DHC) and the differential pressure (Δp) must be carefully matched.

Filtration Terminology

β-value

The β-value as per ISO 16889 is the relevant characteristic value for filtration efficiency. The β-value is the ratio of particles before ($N_{up,x}$) and after ($N_{down,x}$) the filter related to a specific particle size x.

$$\beta_x = \frac{N_{up,x}}{N_{down,x}} \quad (\text{see page C11})$$

Cavitation Damage

Cavitation is defined to be the cavity formation in liquids. Cavitation occurs if the local static pressure of a liquid drops below a critical value. This critical value usually corresponds to the vapour pressure of the liquid. Critical effects of cavitation are:

- Cavitation wear
- Undissolved gas in the hydraulic system
- Loud high-frequency noises
- Local high temperatures in the liquid
- Changes to the resistance characteristics of the hydraulic resistance

Cleanliness Level

The cleanliness level of a hydraulic fluid is defined by the number of solid particles per ml of fluid. The number of particles is usually measured with an automatic particle counter. The cleanliness level is determined by a class code created by counting the number of particles of different sizes.

Particle counting as well as the coding of the cleanliness class for hydraulic oils are described in the ISO 4406 (1999) standard. Beside the ISO 4406 (1999), NAS 1638 (1964) and SAE AS4059 Rev. D (2001) are also still common.

Clogging Indicator

The clogging indicator signals a specific pressure level where the soiled filter element should be replaced. They work with differential pressure (Δp) or back pressure. Clogging indicators are available in visual, electrical and visual/electrical versions. While it is the responsibility of the installation or maintenance personnel to check the degree of clogging of the filter element with visual clogging indicators, a signal contact (switch) can be connected to the machine controller with an electrical or visual/electrical clogging indicator.

Collapse Pressure

The permissible collapse pressure according to ISO 2941 is understood to be the pressure difference that a filter element can withstand with the stipulated direction of flow. Exceeding the collapse pressure results in the destruction of the filter element.

Depth Filter

Impurities penetrate into the filter fabric and are retained by the structure of the filter fabric. Mainly cellulose and inorganic glass fibre media are used in hydraulic filters. For special applications, plastic media (high-strength) and metal fibre media are also used. The design of the depth filter combines the highest micron rating with a high dirt retention capacity. Due to the fleece-like structure of depth filters, particles are not only separated on the surface of the filter material, but they can penetrate into the filter material, which leads to a considerable increase of the effective filter area. In contrast to sieves, there are no holes in fleece, rather they practically consist of labyrinths in which the particles are trapped. Hence, there is no sharply defined screening, rather a wide range of particles are trapped.

Differential Pressure

The differential pressure (Δp) is defined as the pressure difference between the filter inlet and the filter outlet, or alternatively in front of and behind the filter element.

Exceeding the maximum permissible pressure differential leads to the destruction of the filter element.

A bypass valve integrated in the filter prevents destruction of the filter element by opening if the differential pressure (Δp) is too high. Then the oil is passed unfiltered into the hydraulic circuit. For applications in which no unfiltered oil is allowed to pass into the hydraulic circuit, there is the possibility of using filters without bypass valves with filter elements that can withstand a high differential pressure (Δp). The filter elements must be designed such that they can withstand the maximum expected differential pressure (Δp).

Dirt-Hold Capacity (DHC)

The dirt-hold capacity (DHC) shows how much solid dirt a filter element can hold. It is measured in the multipass test according to ISO 16889

EPDM

Ethylene-Propylene-Diene-Monomer-rubber (EPDM) is used as a material for O-rings because of its chemical resistance.

Filter

A filter (hydraulic filter) has the job of keeping solids out of a liquid (oil). A filter is usually made of a filter housing and a filter element.

Filter Area

The filter area is the size of the theoretically spread-out filter element. The larger the filter area, the lower the flow resistance of the filter element. Simultaneously, the dirt-hold capacity (DHC) increases. The following applies in general: the larger the filter area, the longer the service life of the element. Basically the filter area can be enlarged by the number of pleats.

Filter Cake

A filter cake is made up of the particles trapped on the surface of a filter medium.

Filter Design

Essentially depends on the following factors: specific flow rate, cleanliness level, amount of contamination, the maximum pressure setting and the required filter service life.

Filter Element

The filter element is located in the filter housing and performs the actual filtering task.

Filtration Efficiency

Filtration efficiency is a measure of the effectiveness of a filter element for separating solid particles. It is given in percent (see page C11).

Filter Housing

Depending on the application, the filter housing is built into the pressure or return line and must be designed for the specific operating or system pressure and the flow rate. The filter element is located in the filter housing. Depending on the application, the filter housing may be equipped with a bypass valve, a reversing valve, a clogging indicator and other options.

Filter Material

The choice of the right filter material is dependent on different criteria. Amongst others, this includes the type of application, the filter function, degree of contamination or alternatively the required dirt-hold capacity (DHC) as well as requirements of chemical or physical resistance. The following list gives you an overview of how these filter materials differ with regard to specific properties:

Inorganic Glass Fibre

Inorganic Glass Fibre media are among the most important materials in modern filtration. During production, selected fibres (1 mm ... 5 mm long and with a diameter of 3 μm ... 10 μm) are processed into a specific mix. The manufacturing process is very similar to paper production. The fibres are bound with a resin and impregnated. The benefit compared to cellulose paper is a fibre structure that is considerably more homogenous and consequently has larger open pored surfaces. As a result, lower flow resistance is achieved.

- Based on Glass Fibres with acrylic or epoxy resin binding
- High retention and dirt-hold capacity (DHC)
- Excellent separation efficiency of the finest particles due to the three-dimensional labyrinth structure with depth filtration
- Outstanding price/performance ratio

Filter Material (Continuation)
Polyester

- 100% Polyester Fibres with thermal bonding
- High pressure differential resistance
- Good chemical resistance
- High separation efficiency of the finest particles
- Tear-proof structure
- No static charging

Cellulose

- Filter material made of Cellulose Fibres with special impregnation
- Variants with the lowest price with good dirt retention capacity
- Not suitable for water based media

Metal Fibre

- Sintered Metal Fibres with three-dimensional labyrinth structure for depth filtration
- Low flow resistance with high dirt-hold capacity
- Excellent chemical and thermal resistance

Stainless Steel Wire Mesh

Filter elements with a Metal Wire Mesh are often used as a conditionally reusable solution in protection filters, suction filters or return-line filters. Depending on the requirements (micron rating, pressure, dynamics) different types of mesh are used like twill, linen, or also Dutch weave.

- Wire mesh fabric made of material 1.4301 for surface filtration (other material on request)
- Low flow resistance due to large-pored screening surface
- Excellent chemical and thermal resistance
- Cleanable

Flow Rate

This is the amount of fluid that flows past a specific cross-section per unit time. It is given in litres per minute (l/min) or gallons per minute (US GPM).

FPM (Viton®)

Fluorinated rubber is used as a material for O-rings and is characterised by its outstanding resistance to high temperatures, mineral oils, synthetic hydraulic fluids, fuels and chemicals.

Hydraulic Fluid

A pressure liquid is defined to be a fluid used in hydraulic and lubrication systems. According to ISO 6743, the fluids are divided into mineral oil based, flame resistant and biodegradable liquids.

Micron Rating

Regarding micron rating, we must differentiate between the filter materials that are used. To define the micron rating for Inorganic Glass Fibre filter elements, the β -value as per ISO 16889 is commonly used.

Multipass Test

The Multipass Test evaluates the performance of a filter element. Standardised in ISO 16889-2008, this test allows comparable and repeatable results of the elements performance. If a normal filter element life is between a few weeks up to several months, this test reduces this life down to 90 minutes. The element is subjected to a fluid that a large amount of a special test dust ISO MTD contains. Results are given for the β -ratio, dirt-hold capacity (DHC) and differential pressure. It is used for designing hydraulic circuits, developing new filter materials and comparison of different filter elements.

See also page C10 and page C11 to get more information about the outcome data. In former time this test was also known as the Multipass Test ISO 4572.

NBR (Buna-N®)

Nitrile rubber is the most commonly used elastomer for O-rings and other sealing devices. Also known as Buna N, Nitrile is a copolymer of Butadiene and Acrylonitrile (ACN). The name Buna N is derived from Butadiene and Natrium (the Latin name for Sodium, the catalyst used in polymerizing Butadiene). The "N" stands for Acrylonitrile.

Nominal Flow Rate

The nominal flow rate describes the flow rate or the volumetric flow rate for which the respective filter has been designed. It is usually given in litres per minute (l/min) or US Gallons per minute (US GPM) and is an important parameter in the filter design.

Nominal Pressure

Pressure for which the filter is designed and which it can be identified with.

Operating Pressure / System Pressure

Maximum pressure with which the filter may be used.

Surface Filter

Impurities are separated on the surface of the filter element. Surface filters are designed to have uniform pores (gaps), therefore they can almost completely retain specific particle sizes. Surface filters are made of Metal Wire Mesh or Cellulose materials.

Other surface filters are metal-edge filters.

Valve
Bypass Valve

A bypass valve is a valve that is integrated in a filter or filter element and allows the oil to bypass the contaminated filter element if a defined pressure differential is exceeded. Bypass valves are used to protect the filter element.

Non-Return Valve

It prevents the continuation line from draining while the filter element is changed.

Reverse Flow Valve

It is used to bypass the filter element for reversible oil flow so that the fluid does not pass through the filter element in the reverse direction.

Multi-Function Valve

A combination of bypass, reverse flow and non-return valve.

Viscosity

The viscosity of a fluid describes the flow behavior of a liquid. There are the kinematic viscosity ν with the unit "m²/s" and the dynamic viscosity η with the unit "Ns/m²". In the field of filtration, in the design of filters the kinematic viscosity is required for calculating. The kinematic viscosity ν can also be calculated with the dynamic viscosity η and density ρ :

$$\nu = \frac{\eta}{\rho}$$

The kinematic viscosity unit is "mm²/s", before it was called centistokes or Stokes (1 cSt = 1 mm²/s = 10⁻⁶ m²/s). The unit of dynamic viscosity is "Ns/m²", it was previously reported in Poise (10 P = 1 Ns/m² = 1 Pa s).

Choice of Filters

Choice of a Suitable Micron Rating

Generally, the type of components incorporated in the hydraulic system will determine the micron rating required. It has been clearly demonstrated that system components will operate reliably for years if a specific minimum oil cleanliness grade is maintained. Frequently the choice will be determined by the most sensitive component in the system.

a) Operating Filter

To get a rough, first rating of what filter is needed to assure a certain oil cleanliness grade please have a look at page C11.

Apart from the specific flow rate (l/min per cm² of filter area), other factors such as operating environment and condition of seals and breathers can have an effect on the cleanliness grade which can actually be achieved.

b) Protective Filter

Occasionally, protective filters are fitted downstream of major components, e.g. the pump, to collect the debris in case of a catastrophic failure. This avoids total stripping and flushing of the system. For economic reasons, protective filters are normally one grade coarser than the operating filters since they do not significantly contribute to the cleaning of the system and this extends filter service intervals.

Choice of the Optimum Filter

In selecting the filter, the following information must be considered:

- Maximum flow volume (Q_{max}) through the filter including surge flows
- Kinematic viscosity (ν) of the fluid in mm²/s (cSt) at cold start temperature and operating temperature
- Density ρ of the fluid
- Micron rating (μ m): see table on page C11
- Filter material

The aim is to choose a filter whose total differential pressure (Δp) is not higher than $\Delta p_{max} = 1,0$ bar (for pressure filters) or $\Delta p_{max} = 0,5$ bar (for return line filters), in a clean state at the normal operating temperature. These values have been proven in practice to give the optimum service life for the element.

The nominal flow volume of the filter is the obvious reference value for pre-selection and this should be larger than the flow to be filtered.

$$Q_{nom} > Q_{max}$$

Calculations based on the filter data will verify whether the pre-selected filter meets the requirements, at operating temperatures:

$$\begin{aligned} \Delta p_{max} &\leq 1,0 \text{ bar (for pressure filter)} \\ \Delta p_{max} &\leq 0,5 \text{ bar (for return line filter)} \end{aligned}$$

The total differential pressure of the assembly Δp_{Assy} is calculated by adding the differential pressure of the housing Δp_{Hous} and that of the element Δp_{Elem} . Both the kinematic viscosity and density of the operating medium should be considered for the selection, as the flow curves on the pages following have been determined with a kinematic viscosity of $\nu = 30$ cSt and a density of $\rho = 0,86$ kg/dm³. The values of the pressure drops for the Δp_{Hous} and the Δp_{Elem} can be read from the flow curves on the pages following. The values for the kinematic viscosity in cSt and the density in kg/dm³ should be inserted into the following formula:

$$\Delta p_{Assy} = \frac{\rho}{0,86} \cdot \Delta p_{Hous} + \frac{\rho}{0,86} \cdot \frac{\nu}{30} \cdot \Delta p_{Elem}$$

The filter size is suitable if the $\Delta p_{Assy} < \Delta p_{max}$.

If the calculated Δp_{Assy} is higher than Δp_{max} select the next larger filter size and re-calculate until a satisfactory solution is found.

The following two examples explain and help to understand the procedure of calculating a filter. For daily business, it is much easier to use a tool like the "STAUFF Filter Selection" Software. (See page C15)

Examples of Calculation

Example 1: Selection Pressure Filter

System Information: A pressure filter with an Inorganic Glass Fibre element is required immediately after the pump. The system has standard components and is operating at pressures up to 200 bar. The filter shall be fitted with a bypass valve and a visual clogging indicator.

For better understanding only the calculation at the upper temperature is carried out.

Data given:	Q_{max} :	100 l/min
	Oil type:	ISO 68
	Temperature max.:	+50°C
	Viscosity $\nu_{operating}$:	44 mm ² /s
	Density ρ :	0,882 kg/dm ³
	Micron rating:	10 μ m (see table on page C11)

First Step

Pre-selection of the size: SF 045, $Q_{nominal} = 160$ l/min $> Q_{max}$

Pressure drop values (at viscosity of 30 mm²/s) from the flow characteristics:

$$\begin{aligned} \Delta p_{Hous} &= 0,15 \text{ bar} && (\text{SF 045 ... , see page C38}) \\ \Delta p_{Elem} &= 0,77 \text{ bar} && (\text{SE-045 G 10 B, see page C40}) \end{aligned}$$

Determination of the correction factor:

$$\Delta p_{Assy} = \frac{0,882}{0,86} \cdot 0,15 \text{ bar} + \frac{0,882}{0,86} \cdot \frac{44}{30} \cdot 0,77 \text{ bar}$$

$$\Delta p_{Assy} = 1,31 \text{ bar} \geq \Delta p_{max} = 1,0 \text{ bar}$$

Since the actual pressure drop is larger than the allowed pressure drop, a larger filter has to be chosen.

Second Step

Selection of the next larger filter size: SF 070, $Q_{nominal} = 240$ l/min $> Q_{max}$

$$\begin{aligned} \Delta p_{Hous} &= 0,15 \text{ bar} && (\text{SF 070 ... , see page C38}) \\ \Delta p_{Elem} &= 0,45 \text{ bar} && (\text{SE-070 G 10 B, see page C40}) \end{aligned}$$

$$\Delta p_{Assy} = \frac{0,882}{0,86} \cdot 0,15 \text{ bar} + \frac{0,882}{0,86} \cdot \frac{44}{30} \cdot 0,45 \text{ bar}$$

$$\Delta p_{Assy} = 0,83 \text{ bar} \leq \Delta p_{max} = 1,0 \text{ bar}$$

In a clean state, this filter fulfills the requirements and is suitable for the application. The correct filter designation would be **SF070G10B-TB/B/V**.

Example 2: Selection Return Line Filter

System Information: A return line filter with a Cellulose element with a micron rating of 10 µm is required to clean the oil. No clogging indicator is required.

Please note: If the system incorporates either accumulators or cylinders, the return flow can dramatically exceed pump flow and the maximum surge flow should be the flow used to calculate the pressure drop through the filter.

Data given: Q_{max} : 100 l/min
 Oil type: ISO 68
 Temperature max.: +60°C
 Viscosity $\nu_{operating}$: 29 mm²/s
 Density ρ : 0,882 kg/dm³
 Micron rating: 10 µm (see table on page C11)

First Step

Pre-selection of the size: RF 030, $Q_{nominal} = 110 \text{ l/min} > Q_{max}$

Pressure drop values (at viscosity of 30 mm²/s) from the flow characteristics:

$\Delta p_{Hous} = 0,30 \text{ bar}$ (RF 030 ..., see page C66)
 $\Delta p_{Elem} = 0,067 \text{ bar}$ (RE-030 N 10 B, see page C66)

Determination of the correction factor (see page C14):

$$\Delta p_{Assy} = \frac{0,882}{0,86} \cdot 0,30 \text{ bar} + \frac{0,882}{0,86} \cdot \frac{29}{30} \cdot 0,067 \text{ bar}$$

$\Delta p_{Assy} = 0,37 \text{ bar} \leq \Delta p_{max} = 0,5 \text{ bar}$

In a clean state, this filter fulfills the requirements and is suitable for the application. No further calculation is necessary. The correct filter designation would be **RF030N10B/B**.

Filter Selection Software

For daily business, it is much easier to use a software tool for the calculation of filters.

The STAUFF Filter Selection Software gives an outstanding support in calculating and choosing a well-dimensioned filter. The tool assists in calculating the right size and creates a technical and order data sheet.

Please contact STAUFF or your distributor for a free copy of the STAUFF Filter Selection Software.

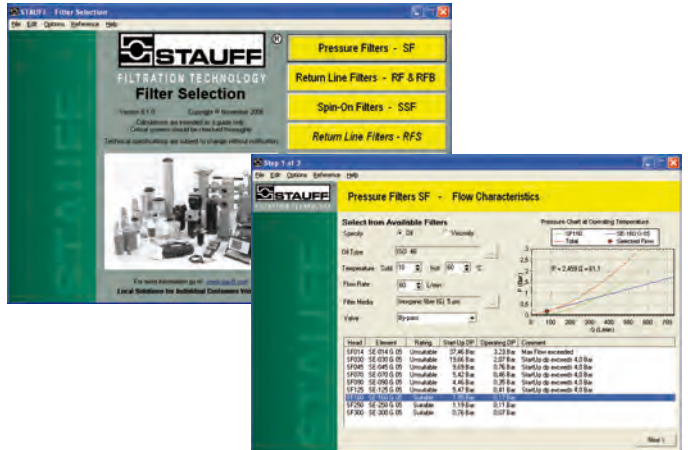

STAUFF Contamination Control Program (SCCP)



The STAUFF Contamination Control Program provides you with a proactive system to control the contamination levels in your hydraulic system.

We offer a Contamination Control Seminar, which includes a PowerPoint presentation and printed literature (only in english language available).

Topics covered include:

- Failures in hydraulic systems
- Contamination types and sources
- Damage caused by contamination
- Fluid cleanliness levels
- Target cleanliness levels
- Contamination control basics
- Filter efficiency
- Measuring fluid level cleanliness
- Practical applications of filtration

To arrange for a presentation contact STAUFF or your distributor.

Besides that, STAUFF has also a wide range of training tools and filtration software to support the proper application of filter systems and products. Software includes filter sizing programs as well as training presentations.

Contact STAUFF for more information.

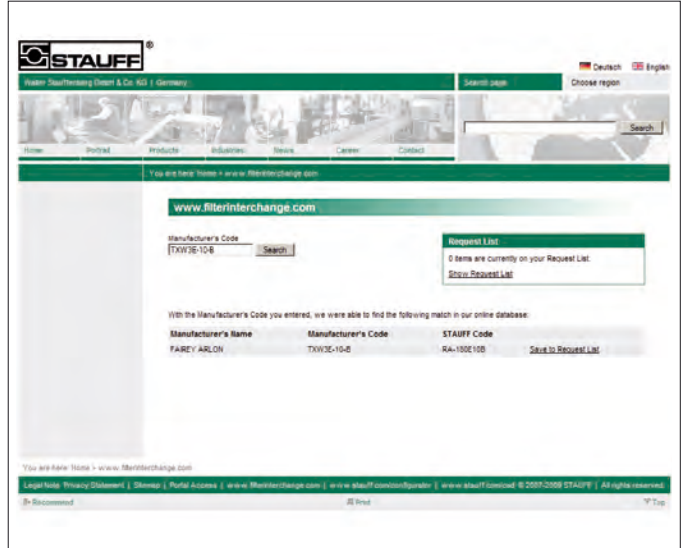

Complete Program

STAUFF manufactures one of the most comprehensive ranges of Replacement Filter Elements for hydraulic and lubrication applications which are compatible with most of the common competitor products.

The STAUFF Replacement Element program includes replacement elements for over 10000 part numbers covering almost every major international brands of filter elements. The majority of these are available from stock.

Continuous improvement of the materials used as well as strict quality controls which take into consideration international standards guarantee the consistently high performance data of the filter elements.

STAUFF impresses in particular with its:

- Innovative research, design and development
- Modern production lines with complete monitoring of production
- Certified work processes in accordance with:
 - ISO 9001: 2008 Quality management
 - ISO 14001: 2004 Environment protection
 - OHSAS 18001: 2007 Occupational health and safety
- Comprehensive stocks and quick delivery
- Customised products in accordance with customer drawings or on the basis of STAUFF designs
- Comprehensive worldwide network of wholly-owned subsidiaries and sales partners

The development and manufacture of STAUFF filter elements are subject to strict testing in accordance with:

- ISO 2941 Collapse and burst resistance
- ISO 2942 Verification of fabrication integrity (bubble point test)
- ISO 2943 Compatibility with hydraulic media
- ISO 3723 End load test
- ISO 3724 Flow fatigue characteristics
- ISO 3968 Flow characteristics
- ISO 16889 Filtration performance test (multi-pass method)

Interchanging STAUFF Filter Elements

As well as original Filter Elements for our own filter housings, STAUFF also provides access to a comprehensive range of Replacement Filter Elements. They match the quality and can be installed in the products of for example:

- Argo-Hytos
- Eppensteiner
- Hydac
- Mahle
- Parker
- Donaldson
- Fairey-Arlon
- Internomen
- Pall
- Other types are available on request

STAUFF offers many possibilities for filter conversion, design and calculation and in so doing supports interested parties and customers with the design of efficient solutions:

- Printed conversion catalogue, available in a five-language version
- Online filter search with more than 65000 data sets under www.filterinterchange.com
- Offline filter database with deposited measurements, filter surfaces and drawings
- Filter selection software for easy filter design and calculation

Thanks to their excellent dirt-hold capacity, all of the filter products supplied by STAUFF have an impressive long service life and high B-value stability:

- Inorganic Glass Fibre, Filter Paper, Stainless Fibre (micron ratings between 3 µm and 20 µm respectively) as well as stainless mesh (micron ratings between 10 µm and 500 µm)
- Maximum differential pressure depending on filter media and application for the options 16 bar / 232 PSI, 30 bar / 435 PSI or 210 bar / 3000 PSI.

Your local STAUFF Distributor will assist you interchanging to STAUFF elements.



The new STAUFF 4Pro Filter Material

Especially to highlight are the new STAUFF glass fibre filter materials 4Pro. The latest generation of inorganic glass fibre filter elements increases the service life of your hydraulic system by up to 60 %.

The new 4Pro filtermaterial offer several advantages:

- High dirt-hold capacity
- Improved filtering capacity
- Extended maintenance intervals
- Reduced operating costs

The 4Pro stands for 4 pros that characterise STAUFF glass fibre materials:

- proActive
- proFessional
- proGressive
- proTecton

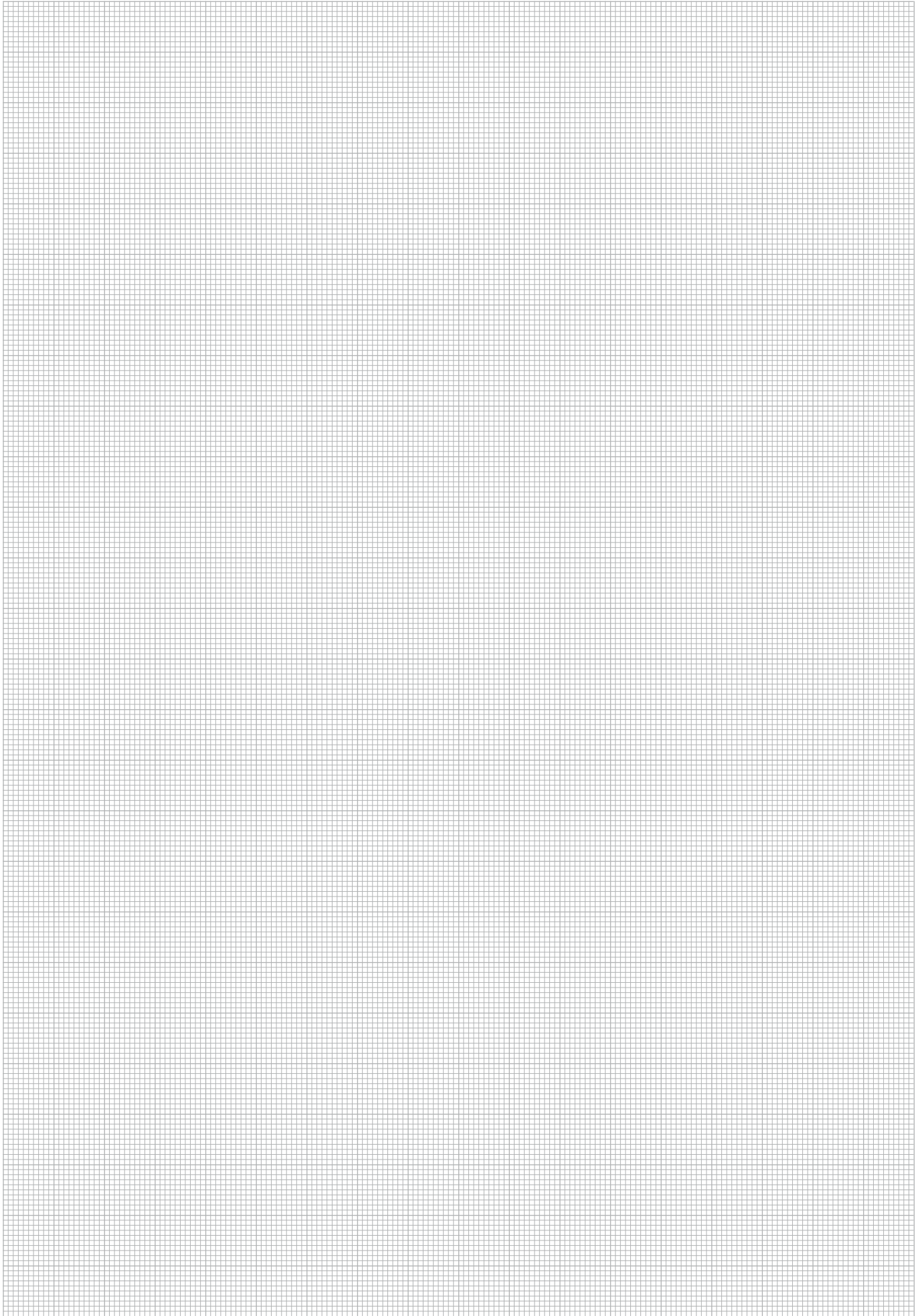

Pressure Filters ■ Types SF / SF-TM / SF-SM / SFA



SF



SF-TM



SF-SM



SFA

Product Description

STAUFF Pressure Filters are designed for manifold mounting or in-line hydraulic applications, with a maximum operating pressure up to 420 bar / 6000 PSI. Used together with STAUFF SE series Filter Elements, a high efficiency of contaminant removal is assured. The high dirt-hold capacity of the elements ensures long service life and, as a result, reduced maintenance costs.

Technical Data

Construction

- SF: Designed for in-line assembly, with threaded mounting holes on top of head.
- SF-TM: Designed for manifold mounting, with mounting holes and fluid ports on top of head.
- SF-SM: Designed for manifold mounting, with mounting holes and fluid ports on side of head.
- SFA: Designed for in-line assembly, with threaded mounting holes on top of head.

Materials

- Filter head: Spheroidal Graphite Cast Iron
Free Cutting Steel (only SF-TM014-070)
SFA: Aluminium
- Filter bowl: Cold Drawn Steel
SFA: Aluminium
- O-rings: NBR (Buna-N®)
FPM (Viton®)
EPDM (Ethylene-Propylene-Diene-Monomer-Rubber)
- Support ring: PTFE (Polytetrafluoroethylene)

Operating Pressure

- SF: max. 420 bar / 6000 PSI
- SF-TM: max. 315 bar / 4560 PSI
- SF-SM: max. 315 bar / 4560 PSI
- SFA: max. 160 bar / 2320 PSI

Temperature Range

- -10 °C ... +100 °C / +14 °F ... +212 °F

Filter Elements

- Specifications see page C37

Media Compatibility

- Mineral oils, other fluids on request

Options and Accessories

Valve

- Bypass valve: Allows unfiltered oil to bypass the contaminated element once the opening pressure has been reached, a differential pressure of $6^{+0.5}$ bar / $87^{+7.25}$ PSI Δp is the standard setting. Other settings available upon request.
- Reverse flow valve: Allows reverse flow through the filter head without backflushing the element.
- Non-return valve: Prevents draining of the delivery line during element change.
- Multi-function valve: Opening pressure $6^{+0.5}$ bar / $87^{+7.25}$ PSI
Bypass, reverse flow capability and non-return valve combined in one valve.

Clogging Indicator

- Standard actuating pressure: $5^{-0.5}$ bar / $72.5^{-7.25}$ PSI Δp
Other actuating pressure settings are available upon request.
- Available indicators: Visual
Electrical
Visual-electrical (24 V DC, 110 V AC, 230 V AC versions)

High Pressure Filters ■ Type SF

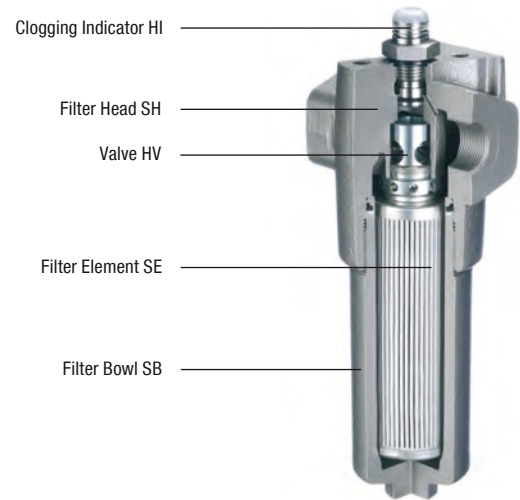
Product Description

STAUFF SF series High Pressure Filters are designed for in-line hydraulic applications, with a maximum operating pressure of 420 bar / 6000 PSI. Used together with STAUFF SE series Filter Elements, a high efficiency of contaminant removal is assured. The high dirt-hold capacity of the elements ensures long service life and, as a result, reduced maintenance costs.

Technical Data
Construction

- Designed for in-line assembly, with threaded mounting holes on top of head.

Materials

- Filter head: Spheroidal Graphite Cast Iron
- Filter bowl: Cold Drawn Steel
- O-rings: NBR (Buna-N®)
FPM (Viton®)
EPDM (Ethylene-Propylene-Diene-Monomer-Rubber)
- Support ring: PTFE (Polytetrafluoroethylene)

Port Connections

- BSP
- NPT
- SAE O-ring thread
- SAE Code 61 flange
- SAE Code 62 flange

Other port connections available on request.

Operating Pressure

- Max. 420 bar / 6000 PSI

Burst Pressure

- Min. 1260 bar / 18275 PSI

Temperature Range

- -10 °C ... +100 °C / +14 °F ... +212 °F

Filter Elements

- Specifications see page C22 / C37

Media Compatibility

- Mineral oils, other fluids on request

Options and Accessories
Valve

- Bypass valve: Allows unfiltered oil to bypass the contaminated element once the opening pressure has been reached, a differential pressure of $6^{+0.5}$ bar / $87^{+7.25}$ PSI Δp is the standard setting. Other settings available upon request.
- Reverse flow valve: Allows reverse flow through the filter head without backflushing the element.
- Non-return valve: Prevents draining of the delivery line during element change.
- Multi-function valve: Opening pressure $6^{+0.5}$ bar / $87^{+7.25}$ PSI
Bypass, reverse flow capability and non-return valve combined in one valve.

Clogging Indicator

- Standard actuating pressure: $5_{-0.5}$ bar / $72.5_{-7.25}$ PSI Δp
Other actuating pressure settings are available upon request.
- Available indicators: Visual
Electrical
Visual-electrical (24 V DC, 110 V AC, 230 V AC versions)

High Pressure Filters ■ Type SF

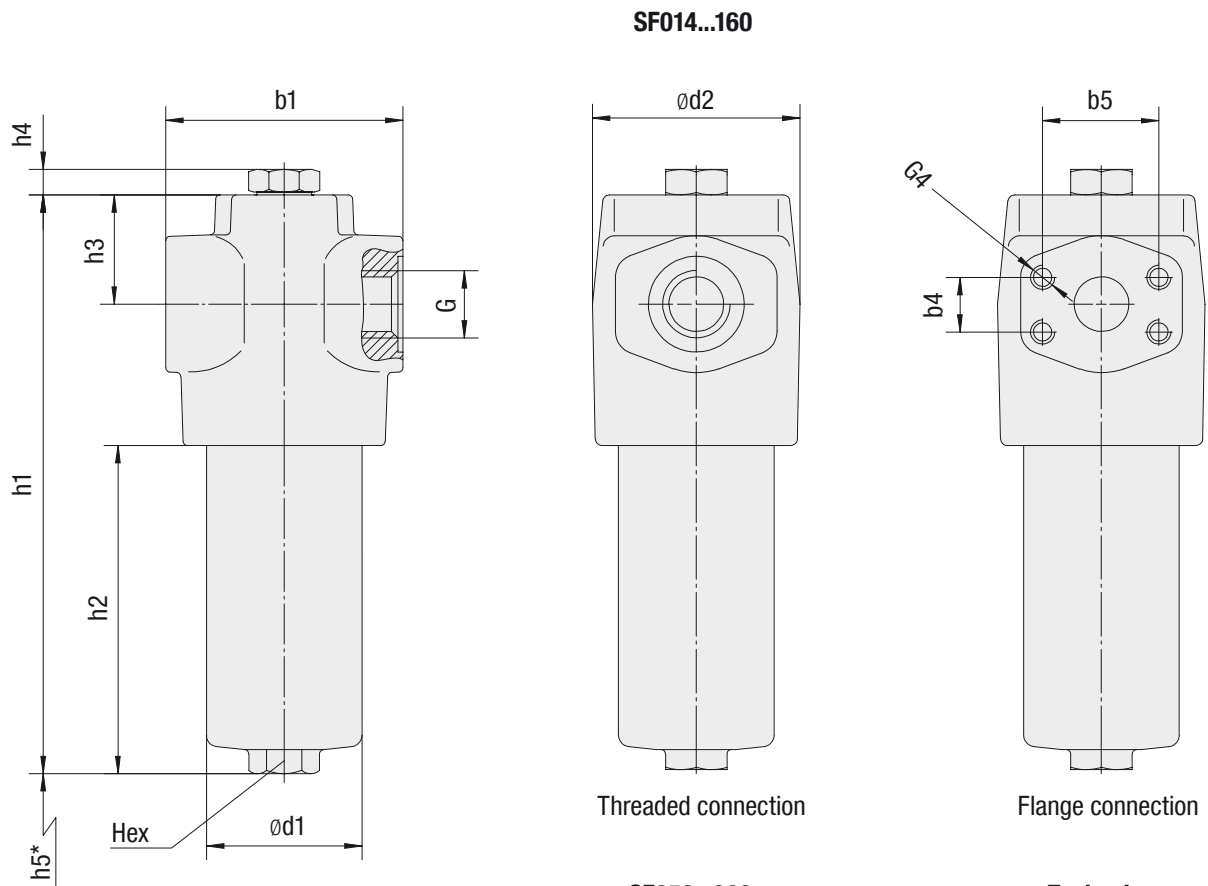

Threaded connection

Flange connection

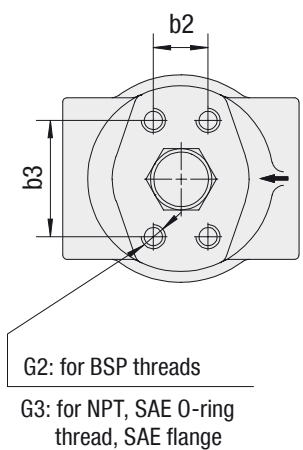

G2: for BSP threads
G3: for NPT, SAE O-ring thread, SAE flange

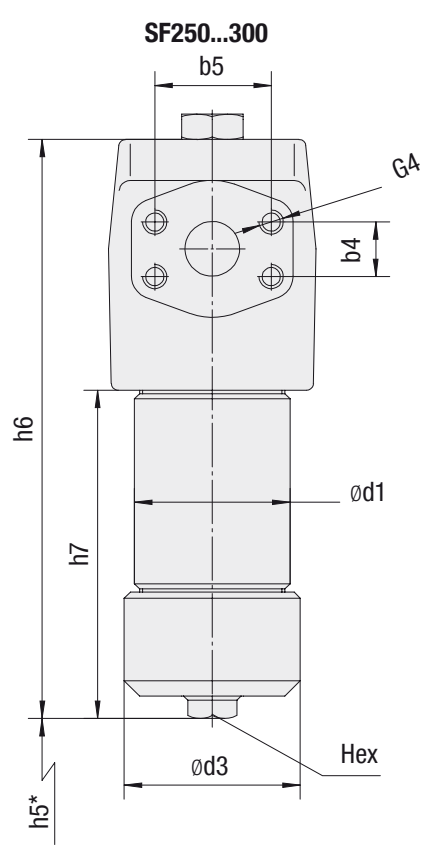

**Toploader
SF014...300..TL**

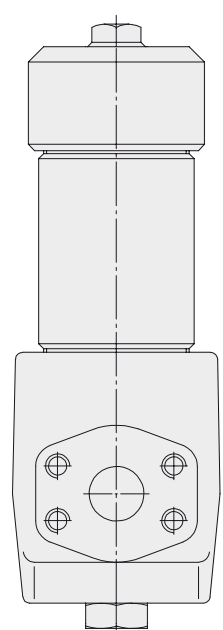

Filter with filterbowl in two-part style for element change from the top

* recommended space for element change

High Pressure Filters ■ Type SF

Thread Connection G	Filter Size SF								
	014	030	045	070	125	090	160	250	300
BSP	3/4	3/4	1-1/4	1-1/4	1-1/4	1-1/2	1-1/2	1-1/2	1-1/2
NPT	3/4	3/4	1-1/4	1-1/4	1-1/4	1-1/2	1-1/2	1-1/2	1-1/2
SAE O-ring Thread	1-1/16-12	1-1/16-12	1-5/8-12	1-5/8-12	1-5/8-12	1-7/8-12	1-7/8-12	1-7/8-12	1-7/8-12
SAE Flange 6000 PSI	3/4	3/4	1-1/4	1-1/4	1-1/4	1-1/2	1-1/2	1-1/2	1-1/2
Weight (kg/lbs) incl. Elements with Filter Bowl in One-Part Style	5,3	6,2	10,3	12	16,3	27	35,5	-	-
	11,7	13,7	22,7	26,5	35,9	59,9	78,3	-	-
Weight (kg/lbs) incl. Elements with Filter Bowl in Two-Part Style	5,9	6,9	12,2	13,7	20	32	39,3	49	57,3
	13	15,2	26,9	30,2	44,1	70,5	86,5	108	126,3

Dimensions (mm/in)		Filter Size SF									
		014	030	045	070	125	090	160	250	300	
b1		104	104	128	128	128	178	178	178	178	
		4.10	4.10	5.04	5.04	5.04	7.01	7.01	7.01	7.01	
d2		91	91	116	116	116	159	159	159	159	
		3.58	3.58	4.57	4.57	4.57	6.26	6.26	6.26	6.26	
h3		48	48	49,5	49,5	49,5	72	72	72	72	
		1.89	1.89	1.95	1.95	1.95	2.84	2.84	2.84	2.84	
h4		12,5	12,5	12,5	12,5	12,5	12,5	12,5	12,5	12,5	
		.49	.49	.49	.49	.49	.49	.49	.49	.49	
with Filter Bowl in One-Part Style Type SF	d1	68	68	95	95	95	130	130	130	130	
		2.68	2.68	3.74	3.74	3.74	5.12	5.12	5.12	5.12	
	h1	188	254	239	298	483	323	494	-	-	
		7.40	10.00	9.41	11.73	19.11	12.72	19.45	-	-	
	h2	78	144	103	161	343	148	319	-	-	
		3.07	5.67	4.06	6.34	13.5	5.83	12.56	-	-	
	h5	Rec.*	100	170	140	200	380	190	360	-	-
		Min.*	3.94	6.69	5.51	7.87	14.96	7.48	14.17	-	-
			85	85	120	120	120	150	150	-	-
	Hex	27	27	32	32	32	36	36	36	36	
1.06		1.06	1.26	1.26	1.26	1.42	1.42	1.42	1.42		
with Filter Bowl in Two-Part Style Type SF...TL	d1	70	70	101,6	101,6	101,6	133	133	133	133	
		2.76	2.76	4	4	4	5.24	5.24	5.24	5.24	
	d3	84	84	115	115	115	155	155	155	155	
		3.31	3.31	4.53	4.53	4.53	6.10	6.10	6.10	6.10	
	h5	65	130	100	160	340	120	290	425	590	
		2.56	5.12	3.94	6.30	13.39	4.72	11.42	16.73	23.23	
	h6	190	256	241	300	485	329,5	500,5	656,5	821,5	
		7.48	10.08	9.49	11.81	19.10	12.97	19.71	25.85	32.34	
	h7	80	146	103	163	344	154,5	325,5	481,5	646,5	
		3.15	5.75	4.06	6.42	13.54	6.08	12.82	18.96	25.45	
Hex	27	27	32	32	32	36	36	36	36		
	1.06	1.06	1.26	1.26	1.26	1.42	1.42	1.42	1.42		

Reference: Rec.*: Recommended | Min.*: Minimum

Dimensions (mm/in)		Filter Size SF								
		014	030	045	070	125	090	160	250	300
T	b2	23,8	23,8	31,6	31,6	31,6	36,7	36,7	36,7	36,7
		.94	.94	1.24	1.24	1.24	1.45	1.45	1.45	1.45
	b3	50,8	50,8	66,7	66,7	66,7	79,4	79,4	79,4	79,4
		2.00	2.00	2.63	2.63	2.63	3.13	3.13	3.13	3.13
Dimensions SAE Flange 6000 PSI	G2	M10 x 15		M14 x 20			M16 x 20			
	G3	3/8-16 UNC x .59		1/2-13 UNC x .79			5/8-11 UNC x .79			
	b4	23,8	23,8	31,6	31,6	31,6	36,7	36,7	36,7	36,7
.94		.94	1.24	1.24	1.24	1.45	1.45	1.45	1.45	
b5	50,8	50,8	66,7	66,7	66,7	79,4	79,4	79,4	79,4	
	2.00	2.00	2.63	2.63	2.63	3.13	3.13	3.13	3.13	
G4	M10 x 15		M14 x 17			M20 x 20				
	3/8-16 UNC		1/2-13 UNC			5/8-11 UNC				

High Pressure Filter Housings / Complete Filters ■ Type SF

SF
014
...
...
B
-
T
B
/
B
/
P
T
230
/
TL
/
X

1
2
3
4
5
6
7
8
9
10
11
12
13

1 Type

High Pressure Filter **SF**

2 Group

Flow	Size
60 l/min / 14 US GPM	014
110 l/min / 30 US GPM	030
160 l/min / 45 US GPM	045
240 l/min / 70 US GPM	070
330 l/min / 90 US GPM	090
475 l/min / 125 US GPM	125
660 l/min / 160 US GPM	160
990 l/min / 250 US GPM	250
1320 l/min / 300 US GPM	300

Note: Exact flow will depend on filter element selected.
Consult technical data on pages C39 / C40.

3 Filter Material

Material	max. Δp*collapse	Micron ratings available	Code
Without filter element	-	-	...
Inorg. glass fibre	25 bar / 363 PSI	3, 5, 10, 20	G
Inorg. glass fibre	210 bar / 3045 PSI		H
Stainless fibre	210 bar / 3045 PSI		A
Stainless mesh	30 bar / 435 PSI	25, 50, 100, 200	B, S

Note: * Collapse/burst resistance as per ISO 2941.
Bold types identify preferred materials, other materials on request.

4 Micron Rating

3 μm	03
5 μm	05
10 μm	10
20 μm	20
25 μm	25
50 μm	50
100 μm	100
200 μm	200

Note: Other micron ratings on request.

5 Sealing Material

NBR (Buna-N®)	B
FPM (Viton®)	V
EPDM	E

Note: Other sealing materials on request.

6 Connecting Flange

Type T	T
--------	----------

7 Connection Style

Connection Style	Group									Thread Style	Code
	014	030	045	070	125	090	160	250	300		
BSP	3/4		1-1/4			1-1/2				metric	B
BSP	1		1-1/2			-				metric	B1
NPT	3/4		1-1/4			1-1/2				UNC	N
SAE O-ring Thread	1-1/16-12		1-5/8-12			1-7/8-12				UNC	U
SAE Flange 6000 PSI	3/4		1-1/4			1-1/2				metric	GM
SAE Flange 6000 PSI	3/4		1-1/4			1-1/2				UNC	GU
SAE Flange 3000 PSI	3/4		1-1/4			1-1/2				metric	FM
SAE Flange 3000 PSI	3/4		1-1/4			1-1/2				UNC	FU
SAE Flange 3000 PSI	1		-			2				metric	F1M
SAE Flange 3000 PSI	1		-			2				UNC	F1U

Note: Other port connections on request. Bold types identify preferred connection styles.

8 Valve

Without valve	O
Bypass valve	B
Reverse flow valve	R
Non-return valve	N
Multi-function valve	M

9 Clogging Indicator

Without clogging indicator	O
Visual, with automatic reset	A
Visual, with manual reset	V
Electrical	E
Visual-electrical	P

10 Thermostop

Without thermostop	none
With thermostop	T

11 Voltage (only for Code P)

24 V DC	24
110 V AC	110
230 V AC	230

12 Style Filter Bowl

With bowl in one-part style	none
Toploader, with bowl in two-part style	TL

Note: Group size SF250 and SF300 only available in TL-version.

13 Design Code

Only for information	X
----------------------	----------

Filter Elements ■ Type SE

SE
-
014
G
10
B
/
X

1
2
3
4
5
6

1 Type

Filter Element Series **SE**

2 Group

According to filter housing

3 Filter Material

Material	max. Δp*collapse	Micron ratings available	Code
Inorganic glass fibre	25 bar / 363 PSI	3, 5, 10, 20	G
Inorganic glass fibre	210 bar / 3045 PSI		H
Stainless fibre	210 bar / 3045 PSI		A
Stainless mesh	30 bar / 435 PSI	25, 50, 100, 200	B, S

Note: * Collapse/burst resistance as per ISO 2941. Bold types identify preferred materials, other materials on request.

4 Micron Rating

3 μm	03
5 μm	05
10 μm	10
20 μm	20
25 μm	25
50 μm	50
100 μm	100
200 μm	200

Note: Other micron ratings on request.

5 Sealing Material

NBR (Buna-N®)	B
FPM (Viton®)	V
EPDM	E

Note: Other sealing materials on request.

6 Design Code

Only for information	X
----------------------	----------

High Pressure Filters ■ Type SF-TM

Product Description

STAUFF SF-TM series High Pressure Filters are designed for manifold block mounting hydraulic applications, with a maximum operating pressure of 315 bar / 4560 PSI. Used together with STAUFF SE series Filter Elements, a high efficiency of contaminant removal is assured. The high dirt-hold capacity of the elements ensures long service life and, as a result, reduced maintenance costs.

Technical Data
Construction

- Designed for manifold mounting, with mounting holes and fluid ports on top of head.

Materials

- Filter head: SF-TM-014-070 Free Cutting Steel
- Filter bowl: SF-TM-090-300 Spheroidal Graphite Cast Iron
- Filter bowl: Cold Drawn Steel
- O-rings: NBR (Buna-N®)
FPM (Viton®)
EPDM (Ethylene-Propylene-Diene-Monomer-Rubber)
- Support ring: PTFE (Polytetrafluoroethylene)

Operating Pressure

- Max. 315 bar / 4560 PSI

Burst Pressure

- Min. 945 bar / 13705 PSI

Temperature Range

- -10 °C ... +100 °C / +14 °F ... +212 °F

Filter Elements

- Specifications see page C26 / C37

Media Compatibility

- Mineral oils, other fluids on request

Options and Accessories
Valve

- Bypass valve: Allows unfiltered oil to bypass the contaminated element once the opening pressure has been reached, a differential pressure of $6^{+0.5}$ bar / $87^{+7.25}$ PSI Δp is the standard setting. Other settings available upon request.
- Reverse flow valve: Allows reverse flow through the filter head without backflushing the element.
- Non-return valve: Prevents draining of the delivery line during element change.
- Multi-function valve: Opening pressure $6^{+0.5}$ bar / $87^{+7.25}$ PSI
Bypass, reverse flow capability and non-return valve combined in one valve.

Clogging Indicator

- Standard actuating pressure: $5_{-0.5}$ bar / $72.5_{-7.25}$ PSI Δp
Other actuating pressure settings are available upon request.
- Available indicators: Visual
Electrical
Visual-electrical (24 V DC, 110 V AC, 230 V AC versions)



High Pressure Filters - Type SF-TM

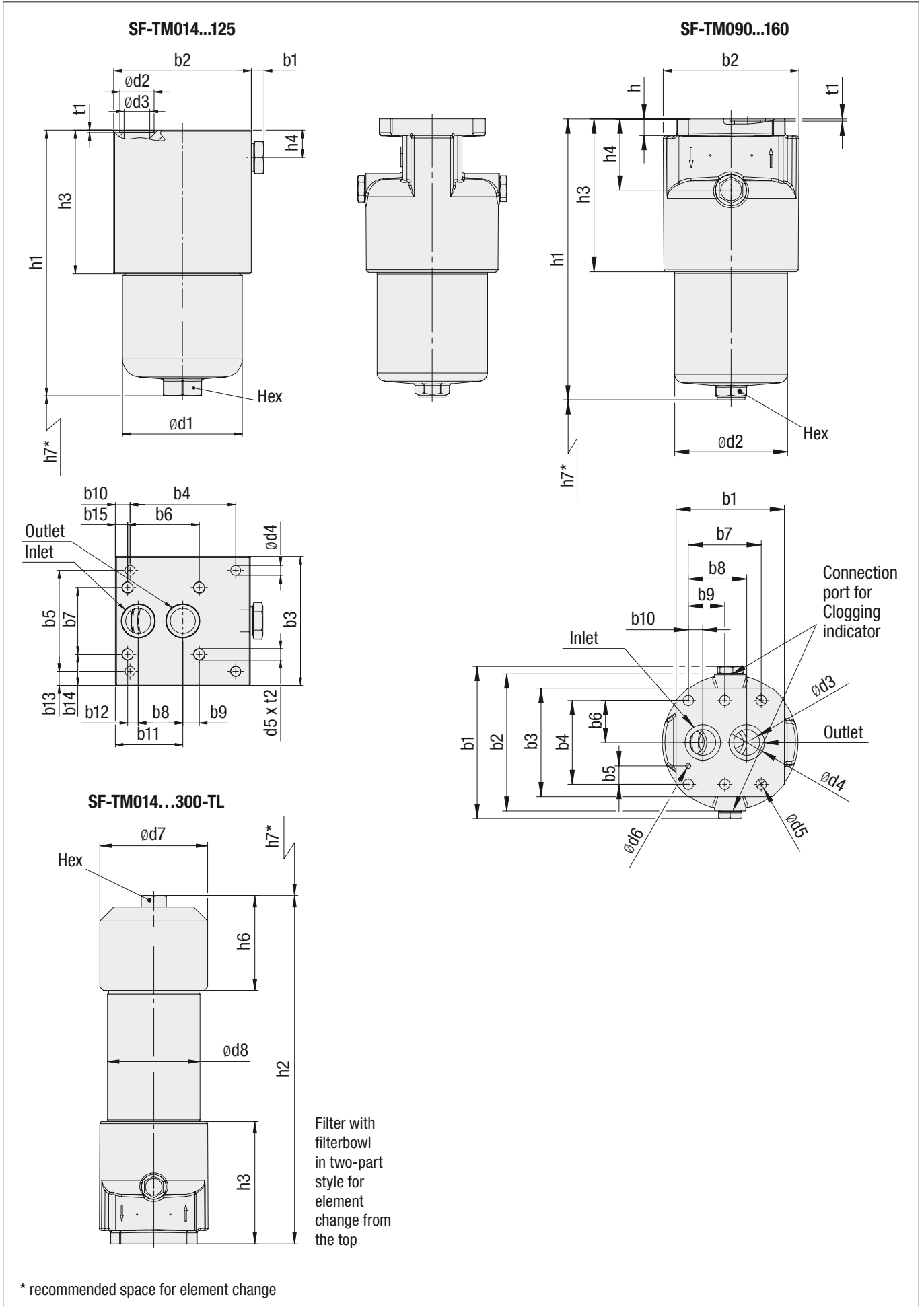

High Pressure Filters - Type SF-TM

Dimensions (mm/in)		Filter Size SF - TM									
		014	030	045	070	125	090	160	250	300	
b1		6	6	6	6	6	175,6	175,6	175,6	175,6	
		.24	.24	.24	.24	.24	6.91	6.91	6.91	6.91	
b2		104	104	115	115	115	158	158	158	158	
		4.09	4.09	4.53	4.53	4.53	6.22	6.22	6.22	6.22	
b3		80	80	110	110	110	125	125	125	125	
		3.35	3.35	4.33	4.33	4.33	4.92	4.92	4.92	4.92	
b4		89	89	90	90	90	96,8	96,8	96,8	96,8	
		3.50	3.50	3.54	3.54	3.54	3.81	3.81	3.81	3.81	
b5		31,8	31,8	86	86	86	21,4	21,4	21,4	21,4	
		1.25	1.25	3.39	3.39	3.39	.84	.84	.84	.84	
b6		-	-	61	61	61	48,4	48,4	48,4	48,4	
		-	-	2.40	2.40	2.40	1.91	1.91	1.91	1.91	
b7		-	-	57	57	57	84,1	84,1	84,1	84,1	
		-	-	2.24	2.24	2.24	3.31	3.31	3.31	3.31	
b8		31,6	31,6	38	38	38	67,4	67,4	67,4	67,4	
		1.24	1.24	1.50	1.50	1.50	2.65	2.65	2.65	2.65	
b9		-	-	14	14	14	42,05	42,05	42,05	42,05	
		-	-	.55	.55	.55	1.66	1.66	1.66	1.66	
b10		7,5	7,5	12,5	12,5	12,5	16,7	16,7	16,7	16,7	
		.30	.30	.49	.49	.49	.66	.66	.66	.66	
b11		55,9	55,9	57,5	57,5	57,5	-	-	-	-	
		2.20	2.20	2.26	2.26	2.26	-	-	-	-	
b12		-	-	9	9	9	-	-	-	-	
		-	-	.35	.35	.35	-	-	-	-	
b13		24,1	24,1	12	12	12	-	-	-	-	
		.95	.95	.47	.47	.47	-	-	-	-	
b14		-	-	26,5	26,5	26,5	-	-	-	-	
		-	-	1.04	1.04	1.04	-	-	-	-	
b15		-	-	10,5	10,5	10,5	-	-	-	-	
		-	-	.41	.41	.41	-	-	-	-	
d1		68,2	68,2	95,2	95,2	95,2	156	156	156	156	
		2.69	2.69	3.75	3.75	3.75	6.14	6.14	6.14	6.14	
d2		25,3	25,3	28,6	28,6	28,6	130,2	130,2	130,2	130,2	
		1.00	1.00	1.13	1.13	1.13	5.13	5.13	5.13	5.13	
d3		17,5	17,5	21,4	21,4	21,4	30	30	30	30	
		.69	.69	.84	.84	.84	1.18	1.18	1.18	1.18	
d4		8,5	8,5	9	9	9	41	41	41	41	
		.33	.33	.35	.35	.35	1.61	1.61	1.61	1.61	
d5		-	-	7/16-14 UNC	7/16-14 UNC	7/16-14 UNC	12	12	12	12	
		-	-				.47	.47	.47	.47	
d6		-	-	-	-	-	6	6	6	6	
		-	-	-	-	-	.24	.24	.24	.24	
d7		84	84	115	115	115	155	155	155	155	
		3.31	3.31	4.53	4.53	4.53	6.10	6.10	6.10	6.10	
d8		70	70	101,6	101,6	101,6	133	133	133	133	
		2.76	2.76	4.00	4.00	4.00	5.24	5.24	5.24	5.24	
h1		162	228	206	264	446	324	495	-	-	
		6.38	8.97	8.11	10.39	17.56	12.76	19.49	-	-	
h2		164	230	206	266	447	330,5	501,5	657,5	822,5	
		6.46	9.06	8.11	10.47	17.60	13.01	19.74	25.89	32.38	
h3		76	76	93	93	93	178	178	178	178	
		2.99	2.99	3.66	3.66	3.66	7.01	7.01	7.01	7.01	
h4		25	25	25	25	25	82	82	82	82	
		.98	.98	.98	.98	.98	3.23	3.23	3.23	3.23	
h5		-	-	-	-	-	19,1	19,1	19,1	19,1	
		-	-	-	-	-	.75	.75	.75	.75	
h6		64	64	82,5	82,5	82,5	136	136	136	136	
		2.52	2.52	3.25	3.25	3.25	5.35	5.35	5.35	5.35	
h7	One-Part Style	Rec.*	100	170	140	200	380	190	360	-	-
		Min.*	3.94	6.69	5.51	7.87	14.96	7.48	14.17	-	-
	Two-Part Style		85	85	120	120	120	150	150	-	-
			3.35	3.35	4.72	4.72	4.72	5.91	5.91	-	-
		65	130	100	160	340	120	290	425	590	
		2.56	5.12	3.94	6.30	13.39	4.72	11.42	16.73	23.23	
t1		2	2	2	2	2	3	3	3	3	
		.08	.08	.08	.08	.08	.12	.12	.12	.12	
t2		-	-	13	13	13	-	-	-	-	
		-	-	.51	.51	.51	-	-	-	-	
Hex		27	27	32	32	32	36	36	36	36	
		1.06	1.06	1.26	1.26	1.26	1.42	1.42	1.42	1.42	
Weight (kg/lbs)	One-Part Style		5,7	6,3	11	12,5	17	21,6	28,8	-	-
			12.5	13.9	24.2	27.8	37.8	48.0	64.0	-	-
	Two-Part Style		6,6	7,3	13,1	14,6	21	26,5	33,8	43,2	54,6
		14.7	16.2	29.1	32.4	46.7	58.9	75.1	96	121.3	

Reference: Rec.*: Recommended | Min.*: Minimum

High Pressure Filter Housings / Complete Filters ■ Type SF-TM

SF-TM
014
...
...
B
-
B
/
B
/
P
T
230
/
TL
/
X

1
2
3
4
5
6
7
8
9
10
11
12

1 Type

High Pressure Filter Top Mounted **SF-TM**

2 Group

Flow	Size
60 l/min / 14 US GPM	014
110 l/min / 30 US GPM	030
160 l/min / 45 US GPM	045
240 l/min / 70 US GPM	070
330 l/min / 90 US GPM	090
475 l/min / 125 US GPM	125
660 l/min / 160 US GPM	160
990 l/min / 250 US GPM	250
1320 l/min / 300 US GPM	300

Note: Exact flow will depend on filter element selected. Consult technical data on pages C39 / C40.

3 Filter Material

Material	max. Δp*collapse	Micron ratings available	Code
Without filter element	-	-	...
Inorg. glass fibre	25 bar / 363 PSI	3, 5, 10, 20	G
Inorg. glass fibre	210 bar / 3045 PSI		H
Stainless fibre	210 bar / 3045 PSI		A
Stainless mesh	30 bar / 435 PSI	25, 50, 100, 200	B, S

Note: * Collapse/burst resistance as per ISO 2941. Bold types identify preferred materials, other materials on request.

4 Micron Rating

3 µm	03
5 µm	05
10 µm	10
20 µm	20
25 µm	25
50 µm	50
100 µm	100
200 µm	200

Note: Other micron ratings on request.

5 Sealing Material

NBR (Buna-N®)	B
FPM (Viton®)	V
EPDM	E

Note: Other sealing materials on request.

6 Connection Size

Connection Size	Group								Code
	014	030	045	070	125	090	160	250	
Nominal Bore	1/2		1-1/4			1-1/2			B

7 Valve

Without valve	0
Bypass valve	B
Reverse flow valve	R
Non-return valve	N
Multi-function valve	M

8 Clogging Indicator

Without clogging indicator	0
Visual, with automatic reset	A
Visual, with manual reset	V
Electrical	E
Visual-electrical	P

9 Thermostop

Without thermostop	none
With thermostop	T

10 Voltage (only for Code P)

24 V DC	24
110 V AC	110
230 V AC	230

11 Style Filter Bowl

With bowl in one-part style	none
Toploader, with bowl in two-part style	TL

Note: Group size SF-TM-250 and SF-TM-300 only available in TL-version.

12 Design Code

Only for information	X
----------------------	----------

Filter Elements ■ Type SE

SE
-
014
G
10
B
/
X

1
2
3
4
5
6

1 Type

Filter Element Series **SE**

2 Group

According to filter housing

3 Filter Material

Material	max. Δp*collapse	Micron ratings available	Code
Inorganic glass fibre	25 bar / 363 PSI	3, 5, 10, 20	G
Inorganic glass fibre	210 bar / 3045 PSI		H
Stainless fibre	210 bar / 3045 PSI		A
Stainless mesh	30 bar / 435 PSI	25, 50, 100, 200	B, S

Note: * Collapse/burst resistance as per ISO 2941. Bold types identify preferred materials, other materials on request.

4 Micron Rating

3 µm	03
5 µm	05
10 µm	10
20 µm	20
25 µm	25
50 µm	50
100 µm	100
200 µm	200

Note: Other micron ratings on request.

5 Sealing Material

NBR (Buna-N®)	B
FPM (Viton®)	V
EPDM	E

Other sealing materials on request

6 Design Code

Only for information	X
----------------------	----------

High Pressure Filters ■ Type SF-SM

Product Description

STAUFF SF-SM series High Pressure Filters are designed for manifold block mounting hydraulic applications, with a maximum operating pressure of 315 bar / 4560 PSI. Used together with STAUFF SE series Filter Elements, a high efficiency of contaminant removal is assured. The high dirt-hold capacity of the elements ensures long service life and, as a result, reduced maintenance costs.

Technical Data
Construction

- Designed for manifold mounting, with mounting holes and fluid ports on side of head.

Materials

- Filter head: Spheroidal Graphite Cast Iron
- Filter bowl: Cold Drawn Steel
- O-rings: NBR (Buna-N®)
FPM (Viton®)
EPDM (Ethylene-Propylene-Diene-Monomer-Rubber)
- Support ring: PTFE (Polytetrafluoroethylene)

Operating Pressure

- Max. 315 bar / 4560 PSI

Burst Pressure

- Min. 945 bar / 13705 PSI

Temperature Range

- -10 °C ... +100 °C / +14 °F ... +212 °F

Filter Elements

- Specifications see page C30 / C37

Media Compatibility

- Mineral oils, other fluids on request

Options and Accessories
Valve

- Bypass valve: Allows unfiltered oil to bypass the contaminated element once the opening pressure has been reached, a differential pressure of $6^{+0.5}$ bar / $87^{+7.25}$ PSI Δp is the standard setting. Other settings available upon request.
- Reverse flow valve: Allows reverse flow through the filter head without backflushing the element.
- Non-return valve: Prevents draining of the delivery line during element change.
- Multi-function valve: Opening pressure $6^{+0.5}$ bar / $87^{+7.25}$ PSI
Bypass, reverse flow capability and non-return valve combined in one valve.

Clogging Indicator

- Standard actuating pressure: $5_{-0.5}$ bar / $72.5_{-7.25}$ PSI Δp
Other actuating pressure settings are available upon request.
- Available indicators: Visual
Electrical
Visual-electrical (24 V DC, 110 V AC, 230 V AC versions)

High Pressure Filters ■ Type SF-SM

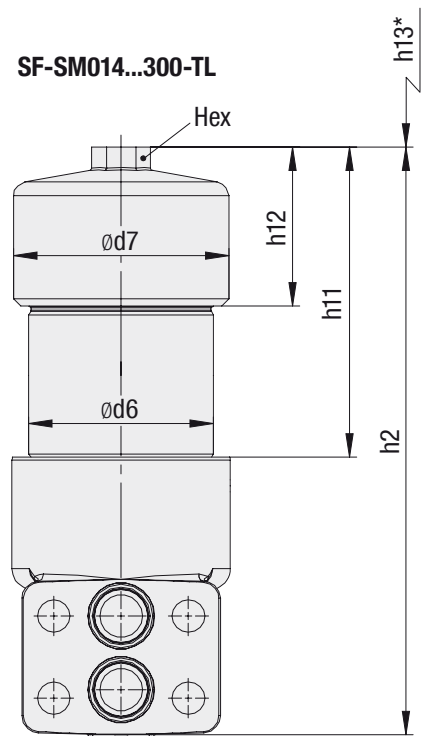
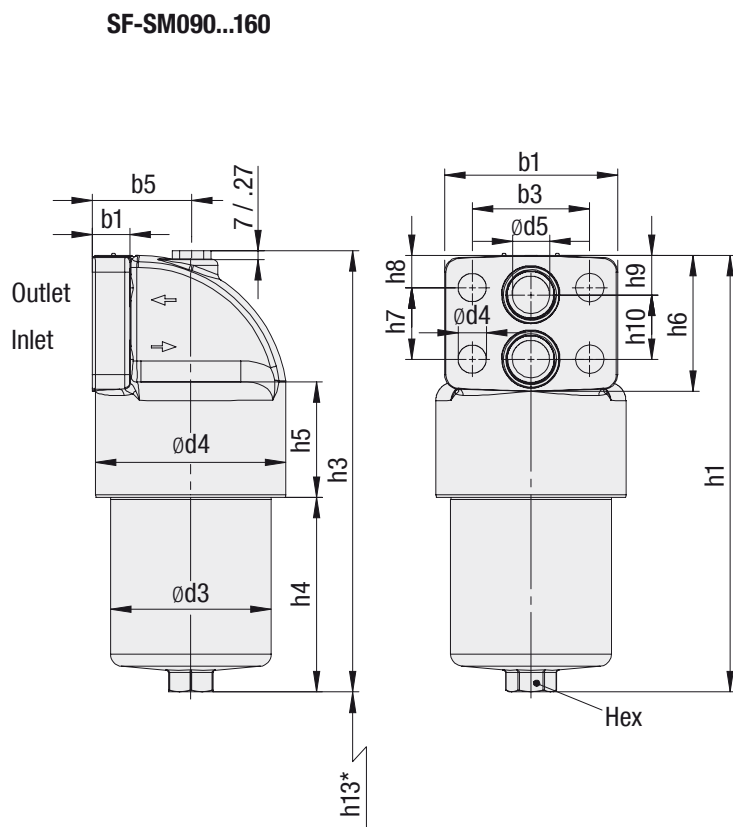
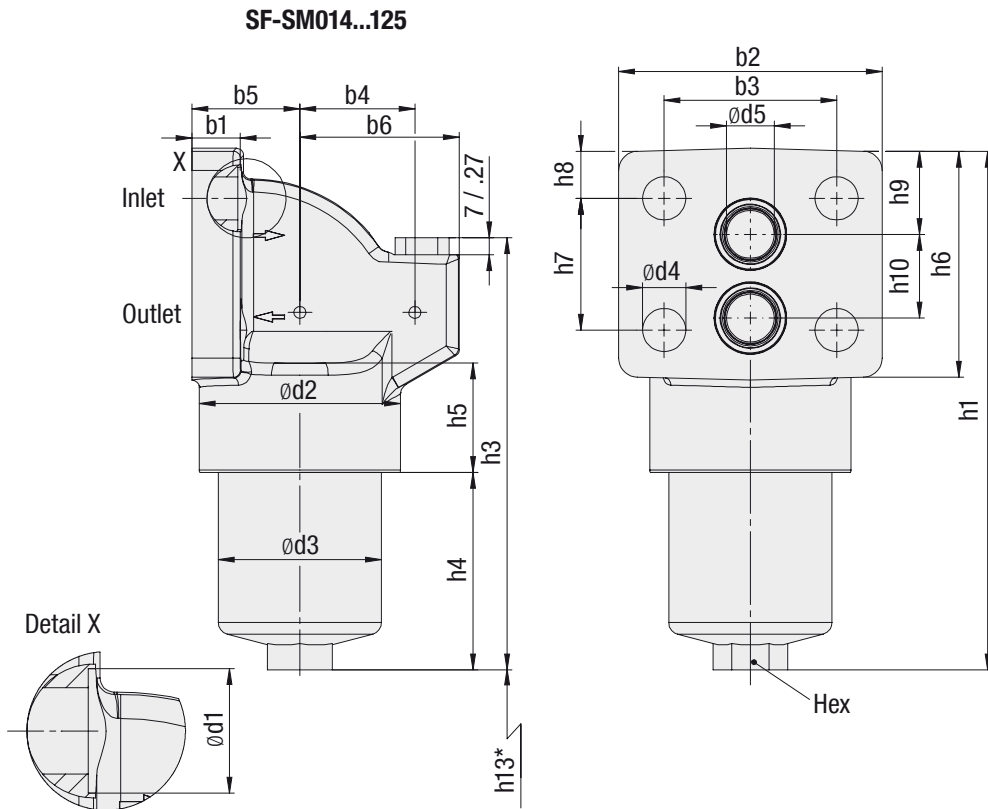

Filter with filterbowl in two-part style for element change from the top

* recommended space for element change

High Pressure Filters ■ Type SF-SM

Dimensions (mm/in)		Filter Size SF - SM												
		014	030	045	045 OAI	070	070 OAI	125	125 OAI	090	160	250	300	
b1		20	20	30	30	30	30	30	30	30	30	30	30	
		.79	.79	1.18	1.18	1.18	1.18	1.18	1.18	1.18	1.18	1.18	1.18	
b2		110	110	140	140	140	140	140	140	140	140	140	140	
		4.33	4.33	5.51	5.51	5.51	5.51	5.51	5.51	5.51	5.51	5.51	5.51	
b3		72	72	95	95	95	95	95	95	95	95	95	95	
		2.83	2.83	3.74	3.74	3.74	3.74	3.74	3.74	3.74	3.74	3.74	3.74	
b4		66	66	89	89	89	89	89	89	-	-	-	-	
		2.60	2.60	3.50	3.50	3.50	3.50	3.50	3.50					
b5		45	45	59	59	59	59	59	59	79,5	79,5	79,5	79,5	
		1.77	1.77	2.32	2.32	2.32	2.32	2.32	2.32	3.13	3.13	3.13	3.13	
b6		48	48	69	69	69	69	69	69	-	-	-	-	
		1.89	1.89	2.72	2.72	2.72	2.72	2.72	2.72					
d1		26	26	32	32	32	32	32	32	32	32	32	32	
		1.02	1.02	1.26	1.26	1.26	1.26	1.26	1.26	1.26	1.26	1.26	1.26	
d2		84	84	116	116	116	116	116	116	154	154	154	154	
		3.31	3.31	4.57	4.57	4.57	4.57	4.57	4.57	6.06	6.06	6.06	6.06	
d3		68	68	95	95	95	95	95	95	130	130	130	130	
		2.68	2.68	3.74	3.74	3.74	3.74	3.74	3.74	5.12	5.12	5.12	5.12	
d4		18	18	22	22	22	22	22	22	23	23	23	23	
		.71	.71	.87	.87	.87	.87	.87	.87	.91	.91	.91	.91	
d5		20	20	32	32	32	32	32	32	30	30	30	30	
		.79	.79	1.26	1.26	1.26	1.26	1.26	1.26	1.18	1.18	1.18	1.18	
d6		70	70	101,5	101,5	101,5	101,5	101,5	101,5	133	133	133	133	
		2.76	2.76	4.00	4.00	4.00	4.00	4.00	4.00	5.24	5.24	5.24	5.24	
d7		84	84	115	115	115	115	115	115	155	155	155	155	
		3.31	3.31	4.53	4.53	4.53	4.53	4.53	4.53	6.10	6.10	6.10	6.10	
h1		217	284	280	284	340	344	506	508	353	523	673	839	
		8.54	11.18	11.02	11.18	13.39	13.54	19.92	20.00	13.90	20.59	26.50	33.03	
h2		219	286	282	286	342	346	507	507	355	525	675	841	
		8.62	11.26	11.10	11.26	13.46	13.62	19.96	19.96	13.98	20.67	26.57	33.11	
h3		181	248	222	239	282	299	464	481	357	527	677	843	
		7.13	9.76	8.74	9.41	11.10	11.77	18.27	18.94	14.06	20.75	26.65	33.19	
h4		83	150	117	119	177	179	343	345	157	329	477	643	
		3.27	5.91	4.61	4.69	6.97	7.05	13.50	13.58	6.18	12.95	18.78	25.31	
h5		45,5	45,5	61	61	61	61	61	61	94	94	94	94	
		1.79	1.79	2.40	2.40	2.40	2.40	2.40	2.40	3.70	3.70	3.70	3.70	
h6		94	94	110	110	110	110	110	110	110	110	110	110	
		3.70	3.70	4.33	4.33	4.33	4.33	4.33	4.33	4.33	4.33	4.33	4.33	
h7		55	55	60	60	60	60	60	60	58	58	58	58	
		2.17	2.17	2.36	2.36	2.36	2.36	2.36	2.36	2.28	2.28	2.28	2.28	
h8		19,5	19,5	25	25	25	25	25	25	26	26	26	26	
		.77	.77	.98	.98	.98	.98	.98	.98	1.02	1.02	1.02	1.02	
h9		34,5	34,5	31	31	31	31	31	31	32	32	32	32	
		1.36	1.36	1.22	1.22	1.22	1.22	1.22	1.22	1.26	1.26	1.26	1.26	
h10		35	35	52	52	52	52	52	52	52	52	52	52	
		1.38	1.38	2.05	2.05	2.05	2.05	2.05	2.05	2.05	2.05	2.05	2.05	
h11		80	146	103	103	163	163	344	344	154,5	325,5	481,5	646,5	
		3.15	5.75	4.06	4.06	6.42	6.42	13.64	13.64	6.08	12.81	18.96	25.45	
h12		64	64	82,5	82,5	82,5	82,5	82,5	82,5	136	136	136	136	
		2.52	2.52	3.25	3.25	3.25	3.25	3.25	3.25	5.35	5.35	5.35	5.35	
h13	One-Part Style	Rec.*	100	170	140	140	200	200	380	380	190	360	-	-
		Min.*	3.94	6.69	5.51	5.51	7.87	7.87	14.96	14.96	7.48	14.17	-	-
	Two-Part Style		85	85	120	120	120	120	120	120	150	150	-	-
			3.35	3.35	4.72	4.72	4.72	4.72	4.72	4.72	5.91	5.91	-	-
			65	130	100	100	160	160	340	340	120	290	425	590
			2.56	5.12	3.94	3.94	6.30	6.30	13.39	13.39	4.72	11.42	16.73	23.23
O-ring		24 x 3	24 x 3	40 x 3,5	40 x 3,5	40 x 3,5	40 x 3,5	40 x 3,5	40 x 3,5	40 x 3,5	40 x 3,5	40 x 3,5	40 x 3,5	
		.95 x .14	.95 x .14	1.57 x .14	1.57 x .14	1.57 x .14	1.57 x .14	1.57 x .14	1.57 x .14	1.57 x .14	1.57 x .14	1.57 x .14	1.57 x .14	
Hex		27	27	32	32	32	32	32	32	36	36	36	36	
		1.06	1.06	1.26	1.26	1.26	1.26	1.26	1.26	1.42	1.42	1.42	1.42	
Weight (kg/lbs)	One-Part Style		5,2	6,1	9,6	10,7	11,6	12,7	15	17	22,9	30,9	-	-
			11,4	13,4	21,1	23,5	25,5	27,9	33,0	37,4	50,4	68,0	-	-
	Two-Part Style		6,1	7,2	11,5	12,6	15,4	16,5	18,8	20,8	27,9	35,9	42,1	50,3
			13,4	15,8	25,3	27,7	33,9	36,3	41,4	45,7	61,4	79,0	92,6	110,6

Reference: Rec.*: Recommended | Min.*: Minimum

High Pressure Filter Housings / Complete Filters ■ Type SF-SM

SF-SM
014
...
...
B
-
B
/
P
T
230
/
TL
/
OAI
/
X

1
2
3
4
5
6
7
8
9
10
11
12

1 Type

High Pressure Filter Side Mounted **SF-SM**

2 Group

Flow	Size
60 l/min / 14 US GPM	014
110 l/min / 30 US GPM	030
160 l/min / 45 US GPM	045
240 l/min / 70 US GPM	070
330 l/min / 90 US GPM	090
475 l/min / 125 US GPM	125
660 l/min / 160 US GPM	160
990 l/min / 250 US GPM	250
1320 l/min / 300 US GPM	300

Note: Exact flow will depend on filter element selected.
Consult technical data on pages C39 / C40.

3 Filter Material

Material	max. Δp*collapse	Micron ratings available	Code
Without filter element	-	-	...
Inorg. glass fibre	25 bar / 363 PSI	3, 5, 10, 20	G
Inorg. glass fibre	210 bar / 3045 PSI		H
Stainless fibre	210 bar / 3045 PSI		A
Stainless mesh	30 bar / 435 PSI	25, 50, 100, 200	B, S

Note: * Collapse/burst resistance as per ISO 2941.
Bold types identify preferred materials, other materials on request.

4 Micron Rating

3 µm	03
5 µm	05
10 µm	10
20 µm	20
25 µm	25
50 µm	50
100 µm	100
200 µm	200

Note: Other micron ratings on request.

5 Seal Material

NBR (Buna-N®)	B
FPM (Viton®)	V
EPDM	E

Note: Other sealing materials on request.

6 Valve

Without valve	0
Bypass valve	B
Reverse flow valve	R
Non-return valve	N
Multi-function valve	M

7 Clogging Indicator

Without clogging indicator	0
Visual, with automatic reset	A
Visual, with manual reset	V
Electrical	E
Visual-electrical	P

8 Thermostop

Without thermostop	none
With thermostop	T

9 Voltage (only for Code P)

24 V DC	24
110 V AC	110
230 V AC	230

10 Style Filterbowl

With bowl in one-part style	none
Toploader, with bowl in two-part style	TL

Note: Group size SF-SM-250 and SF-SM-300 only available in TL-version.

11 Port Connection Location

Inlet above outlet	IAO
Outlet above inlet	OAI

Note: IAO only for SF-SM-014/030/045/070/125
OAI not available for SF-SM-014/030

12 Design Code

Only for information	X
----------------------	----------

Filter Elements ■ Type SE

SE
-
014
G
10
B
/
X

1
2
3
4
5
6

1 Type

Filter Element Series **SE**

2 Group

According to filter housing

3 Filter Material

Material	max. Δp*collapse	Micron ratings available	Code
Inorganic glass fibre	25 bar / 363 PSI	3, 5, 10, 20	G
Inorganic glass fibre	210 bar / 3045 PSI		H
Stainless fibre	210 bar / 3045 PSI		A
Stainless mesh	30 bar / 435 PSI	25, 50, 100, 200	B, S

Note: * Collapse/burst resistance as per ISO 2941. Bold types identify preferred materials, other materials on request.

4 Micron Rating

3 µm	03
5 µm	05
10 µm	10
20 µm	20
25 µm	25
50 µm	50
100 µm	100
200 µm	200

Note: Other micron ratings on request.

5 Sealing Material

NBR (Buna-N®)	B
FPM (Viton®)	V
EPDM	E

Note: Other sealing materials on request

6 Design Code

Only for information	X
----------------------	----------

Medium Pressure Filters ■ Type SFA

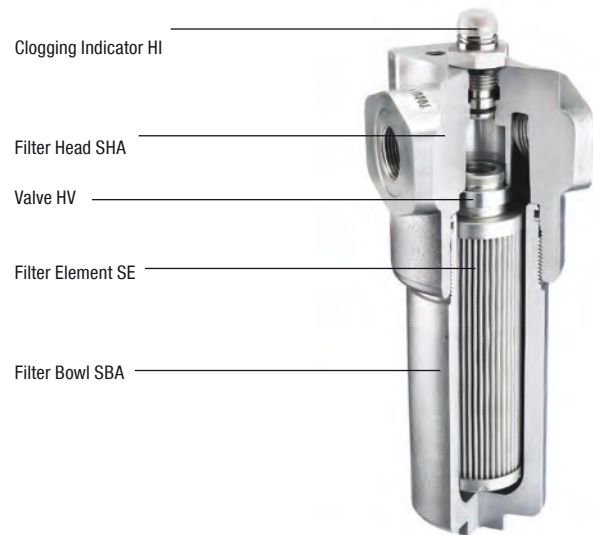
Product Description

STAUFF SFA series Medium Pressure Filters are designed for in-line hydraulic applications with a maximum operating pressure of 160 bar / 2320 PSI. Used together with STAUFF SE series Filter Elements, a high efficiency of contamination removal is assured. The dirt-hold capacity of the elements ensures long service life, and as a result, reduced maintenance costs.

Technical Data
Construction

- Designed for in-line assembly, with threaded mounting holes on top of head.

Materials

- Filter head: Cast Aluminum
- Filter bowl: Aluminium
- O-rings: NBR (Buna-N®)
FPM (Viton®)
EPDM (Ethylene-Propylene-Diene-Monomer-Rubber)
- Support ring: PTFE (Polytetrafluoroethylene)

Port Connections

- BSP
- NPT
- SAE O-ring thread
- SAE Code 61 Flange

Operating Pressure

- SFA014/030: Max. 160 bar / 2320 PSI
Max. 190 bar / 2755 PSI (according to ANSI T2.6.1. R2-2001)
- SFA045/070: Max. 150 bar / 2175 PSI
Max. 171 bar / 2480 PSI (according to ANSI T2.6.1. R2-2001)

Burst Pressure

- Min. 480 bar / 6960 PSI

Temperature Range

- -10 °C ... +100 °C / +14 °F ... +212 °F

Filter Elements

- Specifications see page C34 / C37

Media Compatibility

- Mineral oils, other fluids on request

Options and Accessories
Valve

- Bypass valve: Allows unfiltered oil to bypass the contaminated element once the opening pressure has been reached, a differential pressure of $6^{+0.5}$ bar / $87^{+7.25}$ PSI Δp is the standard setting. Other settings available upon request.
- Reverse flow valve: Allows reverse flow through the filter head without backflushing the element.
- Non-return valve: Prevents draining of the delivery line during element change.
- Multi-function valve: Opening pressure $6^{+0.5}$ bar / $87^{+7.25}$ PSI
Bypass, reverse flow capability and non-return valve combined in one valve.

Clogging Indicator

- Standard actuating pressure: $5_{-0.5}$ bar / $72.5_{-7.25}$ PSI Δp
Other actuating pressure settings are available upon request.
- Available indicators: Visual
Electrical
Visual-electrical (24 V DC, 110 V AC, 230 V AC versions)

Medium Pressure Filters ■ Type SFA

SFA014...070

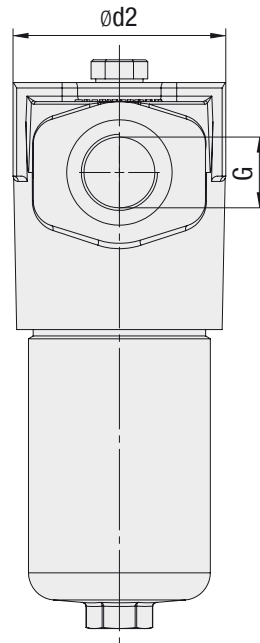
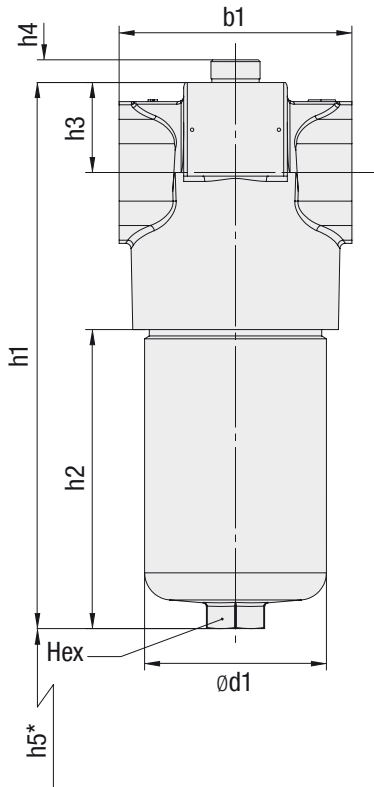

Threaded connection

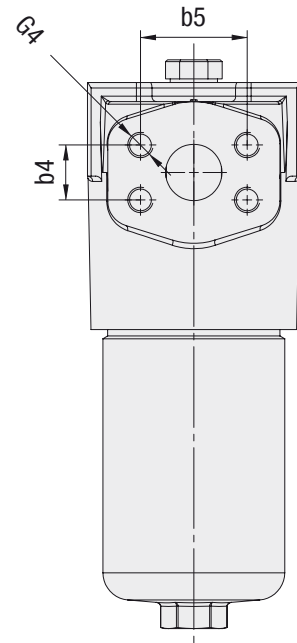

Flange connection

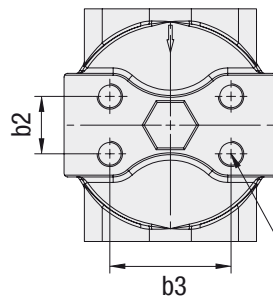

G2: for BSP threads
G3: for NPT, SAE O-ring thread, SAE flange

* recommended space for element change

Medium Pressure Filters ■ Type SFA

Thread Connection G	Filter Size SFA			
	014	030	045	070
BSP	3/4	3/4	1-1/4	1-1/4
NPT	3/4	3/4	1-1/4	1-1/4
SAE O-ring Thread	1-1/6-12	1-1/6-12	1-5/8-12	1-5/8-12
SAE Flange 3000 PSI	3/4	3/4	3/4	3/4
Weight (kg/lbs)	2,1	2,54	4,6	5,3
	4,7	5,6	10,2	11,8

Dimensions (mm/in)	Filter Size SFA			
	014	030	045	070
b1	92	92	128	128
	3.62	3.62	5.04	5.04
b2	23,8	23,8	31,6	31,6
	.94	.94	1.24	1.24
b3	50,8	50,8	66,7	66,7
	2.00	2.00	2.63	2.63
d1	72	72	100	100
	2.83	2.83	3.93	3.93
d2	86	86	117	117
	3.39	3.39	4.61	4.61
h1	187,5	255	241,5	301
	7.38	10.04	9.51	11.85
h2	78	145,5	105	164,5
	3.07	5.73	4.13	6.46
h3	40	40	49,5	49,5
	1.58	1.58	1.95	1.95
h4	12,5	12,5	12,5	12,5
	.49	.49	.49	.49
h5	100	170	140	200
	3.94	6.69	5.51	7.87
	Rec.*			
h5	85	85	120	120
	3.35	3.35	4.72	4.72
Hex	27	27	32	32
	1.05	1.05	1.25	1.25
G2	M10 x 15	M10 x 15	M14 x 20	M14 x 20
G3	3/8-16 UNC x .59	3/8-16 UNC x .59	1/2-13 UNC x .59	1/2-13 UNC x .59

Reference: Rec.*: Recommended | Min.*: Minimum

Dimensions SAE Flange 3000 PSI (mm/in)	Filter Size SFA			
	014	030	045	070
b4	22,2	22,2	47,6	47,6
	.87	.87	1.87	1.87
b5	30,2	30,2	58,7	58,7
	1.19	1.19	2.32	2.32
G4	M10 x 15 or	M10 x 15 or	M14 x 17 or	M14 x 17 or
	3/8-16 UNC	3/8-16 UNC	7/8-14 UNC	7/8-14 UNC

Medium Pressure Filter Housings / Complete Filters ■ Type SFA

SFA
014
...
...
V
-
T
B
/
B
/
P
T
230
/
X

1
2
3
4
5
6
7
8
9
10
11
12

1 Type

Medium Pressure Filter **SFA**

2 Group

Flow	Size
60 l/min / 14 US GPM	014
110 l/min / 30 US GPM	030
160 l/min / 45 US GPM	045
240 l/min / 70 US GPM	070

Note: Exact flow will depend on filter element selected. Consult technical data on pages C39 / C40.

3 Filter Material

Material	max. Δp*collapse	Micron ratings available	Code
Without filter element	-	-	...
Inorg. glass fibre	25 bar / 363 PSI	3, 5, 10, 20	G
Inorg. glass fibre	210 bar / 3045 PSI		H
Stainless fibre	210 bar / 3045 PSI		A
Stainless mesh	30 bar / 435 PSI	25, 50, 100, 200	B, S

Note: * Collapse/burst resistance as per ISO 2941. Bold types identify preferred materials, other materials on request.

4 Micron Rating

3 μm	03
5 μm	05
10 μm	10
20 μm	20
25 μm	25
50 μm	50
100 μm	100
200 μm	200

Note: Other micron ratings on request.

5 Sealing Material

NBR (Buna-N®)	B
FPM (Viton®)	V
EPDM	E

Note: Other sealing materials on request.

6 Connection Flange

Type T	T
--------	----------

7 Connection Style

Connection Style	Group					Thread Style	Code
	014	030	045	070	125		
BSP	3/4		1-1/4			metric	B
BSP	1		1-1/2			metric	B1
NPT	3/4		1-1/4			UNC	N
SAE O-ring Thread	1-1/16-12		1-5/8-12			UNC	U
SAE Flange 3000 PSI	3/4		1-1/4			metric	FM
SAE Flange 3000 PSI	3/4		1-1/4			UNC	FU
SAE Flange 3000 PSI	1		-			metric	F1M
SAE Flange 3000 PSI	1		-			UNC	F1U

Note: Other port connections on request. Bold types identify preferred connection styles.

8 Valve

Without valve	0
Bypass valve	B
Reverse flow valve	R
Non-return valve	N
Multi-function valve	M

9 Clogging Indicator

Without clogging indicator	0
Visual, with automatic reset	A
Visual, with manual reset	V
Electrical	E
Visual-electrical	P

10 Thermostop

Without thermostop	none
With thermostop	T

11 Voltage (only for Code P)

24 V DC	24
110 V AC	110
230 V AC	230

12 Design Code

Only for information	X
----------------------	----------

Filter Elements ■ Type SE

SE
-
014
G
10
B
/
X

1
2
3
4
5
6

1 Type

Filter Element Series **SE**

2 Group

According to filter housing

3 Filter Material

Material	max. Δp*collapse	Micron ratings available	Code
Inorganic glass fibre	25 bar / 363 PSI	3, 5, 10, 20	G
Inorganic glass fibre	210 bar / 3045 PSI		H
Stainless fibre	210 bar / 3045 PSI		A
Stainless mesh	30 bar / 435 PSI	25, 50, 100, 200	B, S

Note: Collapse/burst resistance as per ISO 2941. Bold types identify preferred materials, other materials on request.

4 Micron Rating

3 μm	03
5 μm	05
10 μm	10
20 μm	20
25 μm	25
50 μm	50
100 μm	100
200 μm	200

Note: Other micron ratings on request.

5 Sealing Material

NBR (Buna-N®)	B
FPM (Viton®)	V
EPDM	E

Note: Other sealing materials on request.

6 Design Code

Only for information	X
----------------------	----------

Product Description

The optional valves are fitted as an insert in the filter head and incorporate the spigot on which the element seals. The valve is selected to suit the filter application.

<p>HV-O Non-bypass standard insert without any valve function. Element collapse rating should be higher than system pressure</p>	<p>HV-N Non-return valve This valve prevents the oil in the delivery line from draining out while the filter is being serviced. Because there is no bypass, the element collapse rating should be higher than system pressure.</p>
<p>HV-B Bypass valve which allows oil to bypass the element when the differential pressure across the element reaches $6^{+0.5}$ bar / $87^{+7.25}$ PSI. (Other pressure settings available on request). The opening pressure should be higher than the Δp setting of an optional clogging indicator. Low collapse 30 bar / 435 PSI Δp elements are normally used with this valve.</p>	<p>HV-M Multi-function valve This valve combines the bypass, the reverse flow and the non-return functions in one unit. The by-pass opening pressure is $6^{+0.5}$ bar / $87^{+7.25}$ PSI Δp with other opening pressures available on request. The opening pressure should be higher than the Δp setting of an optional clogging indicator. Low collapse 30 bar / 435 PSI Δp elements are normally used with this valve.</p>
<p>HV-R Reverse flow valve is used in systems where there is flow in reverse through the filter. It allows reverse flow without backflushing the element but does not filter in the reverse direction. Element collapse rating should be higher than the system pressure.</p>	

Order Code

HV - M 014 / 030 / X

1 2 3 4

1 Type

Valve for Pressure Filters	HV
----------------------------	-----------

2 Valve Type

Non-bypass standard insert without any valve	O
Bypass valve	B
Reverse flow valve	R
Non-return valve	N
Multi-function valve	M

3 Filter Group

For filter size 014/030	014/030
For filter size 045/070/125	045/070
For filter size 090/160/250/300	090/160

4 Design Code

Only for information	X
----------------------	----------

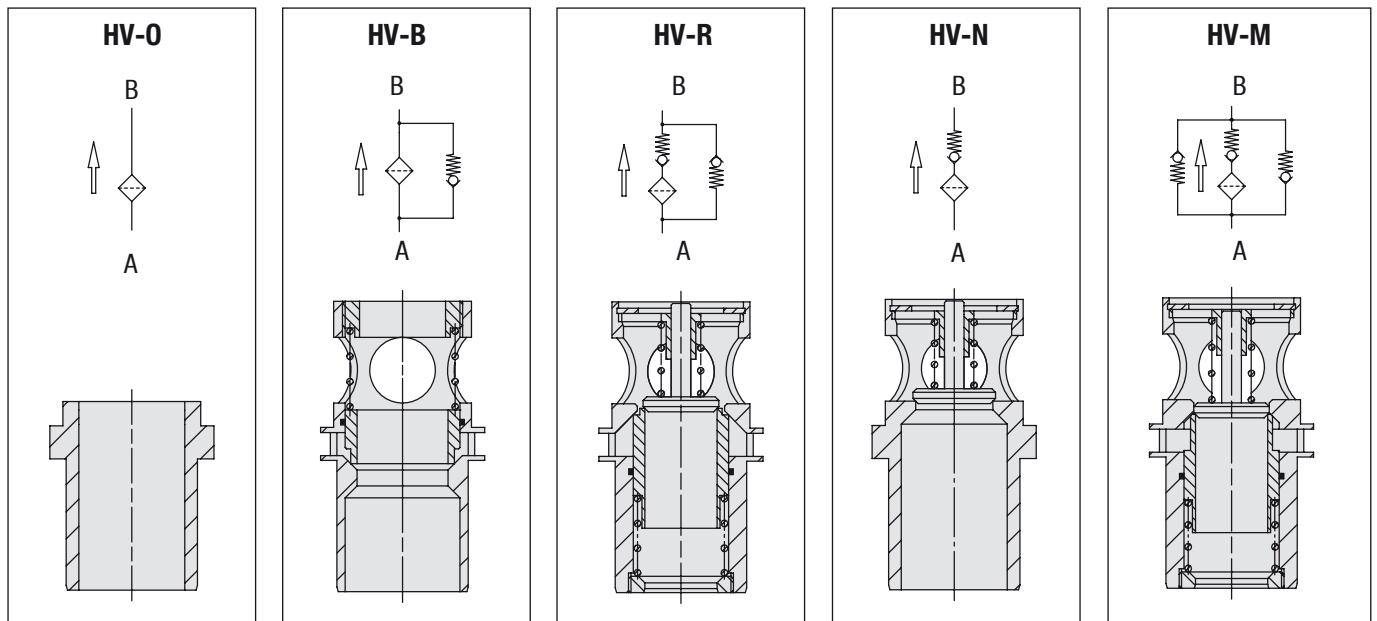

Flow characteristics of the valves see page C38

Clogging Indicators

Product Description

STAUFF Pressure Filters have a wide range of clogging indicators available. If no indicator is specified, the port is sealed by a plug (HI-0). The clogging indicators are actuated by the differential pressure (Δp) across the element. The special piston design minimizes the effects of peak pressures in the system. An optional thermal lockout (thermo-stop) is available to prevent false indication under cold start conditions. Fluid temperature have to be at least +20 °C / +68 °F for the indicator to function. Special indicators with a temperature range down to -45 °C / -49 °F are available upon request.

Technical Data

Materials

- Body: Stainless Steel
- Sealings: NBR (Buna-N®)
FPM (Viton®)
EPDM (Ethylene-Propylene-Diene-Monomer-Rubber)

Thread

- G 1/2

Differential Pressure

- 5_{-0,5} bar / 72.5_{-7,25} PSI pressure setting (other settings on request)

Electrical

- Plug according to DIN-EN 175301-803 A (DIN 43650-A). Screwed cable gland PG11, protection rating (DIN 40050) IP65, both NO and NC contacts are available in the switch, rated capacity: see chart below

The visual clogging indicators are available in the following configurations:

- Manual reset: The indicator continues to display the clogged signal even through the Δp may have fallen. Pressing the plastic cover down will reset the indicator.
- Automatic reset: The clogged signal will disappear when the Δp drops below the setting for the indicator.

Electrical and visual-electrical clogging indicators are only available with automatic reset.

Order Code

HI - P T 230 B 5,0B / X

1
 2
 3
 4
 5
 6
 7

1 Type

Clogging Indicator for Pressure Filters **HI**

2 Indicator Type

Plug **O**
 Visual, automatic reset **A**
 Visual, manual reset **V**
 Electrical **E**
 Visual-electrical **P**

3 Thermostop

Without thermostop **none**
 With thermostop **T**

4 Voltage (only for Code P)

24 V DC **24**
 110 V AC **110**
 230 V AC **230**

5 Sealing Material

NBR (Buna-N®) **B**
 FPM (Viton®) **V**
 EPDM **E**

6 Differential Pressure Setting

1,72 bar / 25 PSI **25P**
 2,0 bar / 29 PSI **2,0B**
 3,0 bar / 43.5 PSI **3,0B**
 5,0 bar / 72.5 PSI (standard option) **5,0B**
 7,0 bar / 101.5 PSI **7,0B**

7 Design Code

Only for information **X**

Dimensions

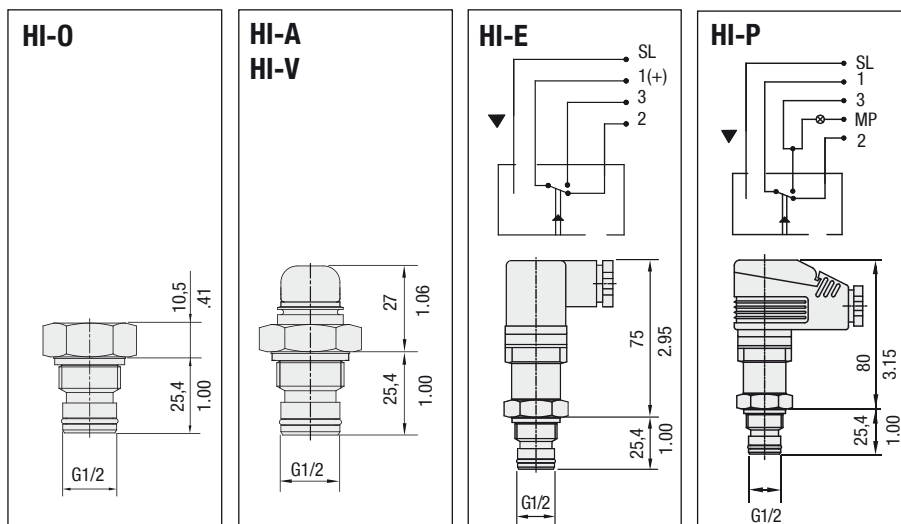

Rated Capacity HI-E and HI-P

Alternating current: 250 V AC 5 A

Direct current: see table below

Voltage V	Resistive Load A	Inductive Load A
24 V DC	8,00	7,00
110 V AC	0,50	0,20
230 V AC	0,25	0,10

High voltage peaks occur when inductive loads are switched off. Protective circuitry should be employed to reduce contact burnout.

High and Medium Pressure Filters ■ Type SF / SF-TM / SF-SM / SFA Filter Elements SE

Product Description

STAUFF SE series Replacement Filter Elements for SF / SF-TM / SF-SM / SFA series filter housings are manufactured in the common filter materials such as Stainless Fibre, Stainless Mesh and Inorganic Glass Fibre. As standard, all Replacement Elements SE series for SF / SF-TM / SF-SM / SFA, have tin-plated steel parts for use with aggressive media such as water glycol, other materials available on request. All STAUFF Replacement Elements comply with quality specifications in accordance with international standards.

Order Code

SE - 014 G 10 B / X

1 2 3 4 5 6

1 Type

Filter Element Series **SE**

2 Group

According to filter housing

3 Filter Material

Material	max. Δp^* collapse	Micron ratings available	Code
Inorganic glass fibre	25 bar / 363 PSI	3, 5, 10, 20	G
Inorganic glass fibre	210 bar / 3045 PSI		H
Stainless fibre	210 bar / 3045 PSI		A
Stainless mesh	30 bar / 435 PSI	25, 50, 100, 200	B, S

Note: * Collapse/burst resistance as per ISO 2941. Bold types identify preferred materials, other materials on request.

4 Micron Rating

3 μm	03
5 μm	05
10 μm	10
20 μm	20
25 μm	25
50 μm	50
100 μm	100
200 μm	200

Note: Other micron ratings on request.

5 Sealing Material

NBR (Buna-N®)	B
FPM (Viton®)	V
EPDM	E

Note: Other sealing materials on request.

6 Design Code

Only for information	X
----------------------	----------

High and Medium Pressure Filters - Type SF / SF-TM / SF-SM / SFA

The following characteristics are valid for mineral oils with a density of 0,85 kg/dm³ and the kinematic viscosity of 30 mm²/s (30 cSt). The characteristics have been determined in accordance to ISO 3968. Multipass filter ratings have been obtained in accordance to ISO 16889. Consult STAUFF for details.

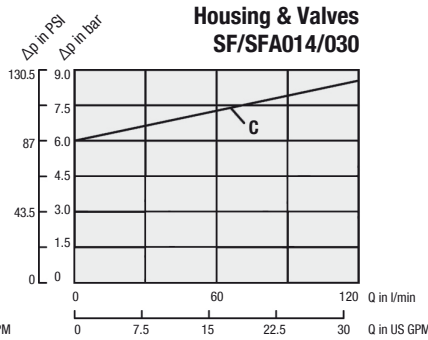
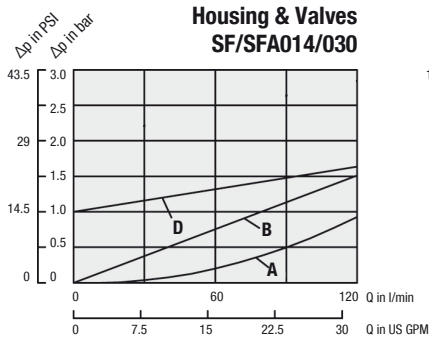

Valve Configuration	Flow direction	Curve
Housing with HV-O or HV-B	In → Out	A
HVM, HV-R, HV-N	In → Out	B
HV-M, HV-B ▪ Element 100% blocked Bypass only ▪ In reality always mixed mode	In → Out	C
HV-M, HV-R Reverse mode	Out → In	D

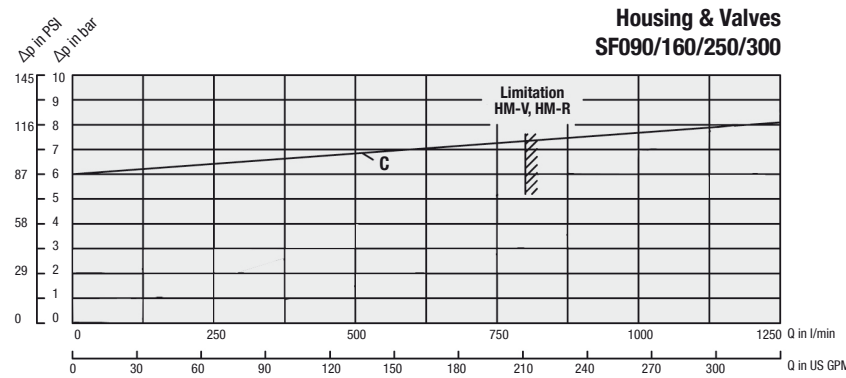
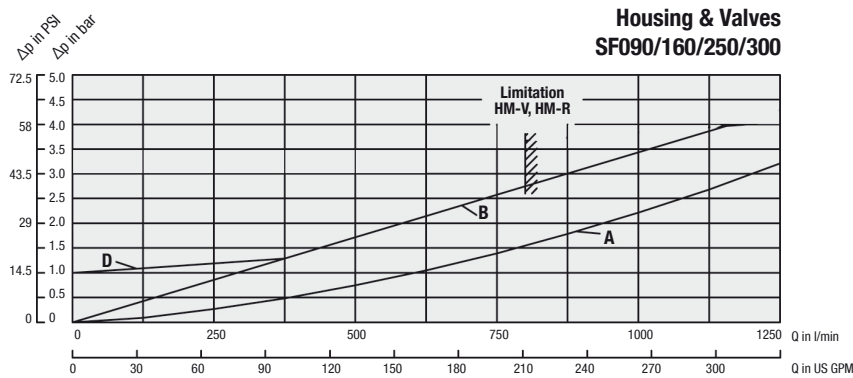
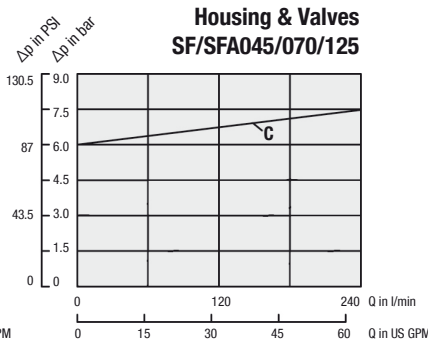
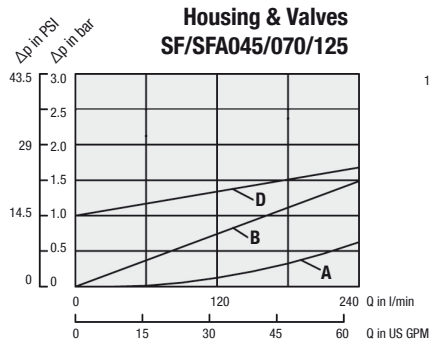

High and Medium Pressure Filters ■ Type SF / SF-TM / SF-SM / SFA

The following characteristics are valid for mineral oils with a density of 0,85 kg/dm³ and the kinematic viscosity of 30 mm²/s (30 cSt). The characteristics have been determined in accordance to ISO 3968. Multipass filter ratings have been obtained in accordance to ISO 16889. Consult STAUFF for details.

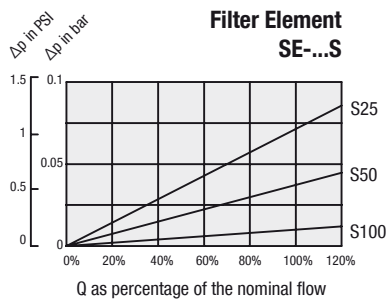
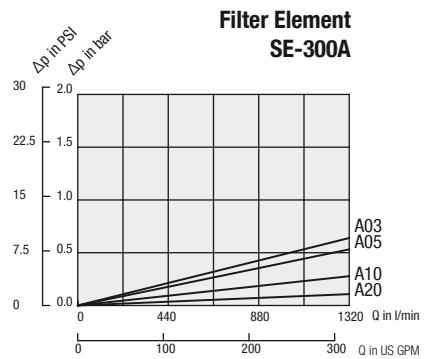
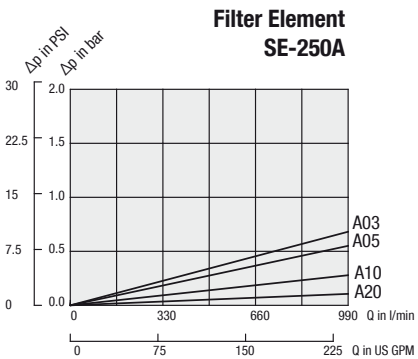
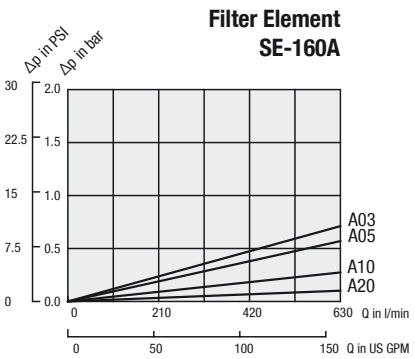
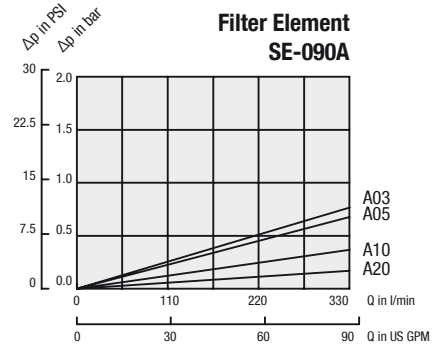
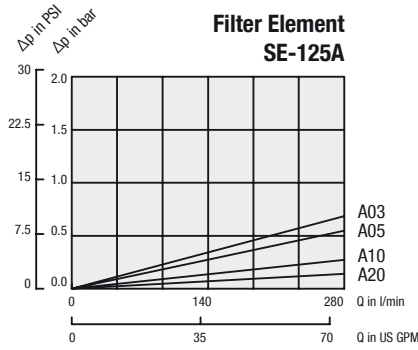
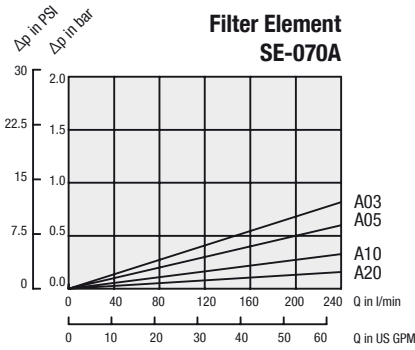
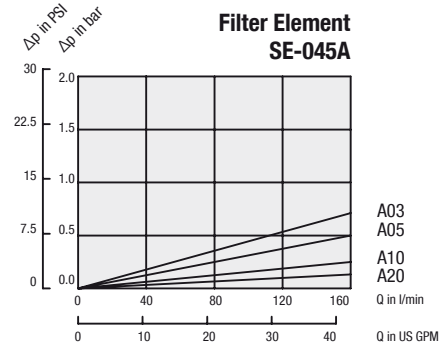
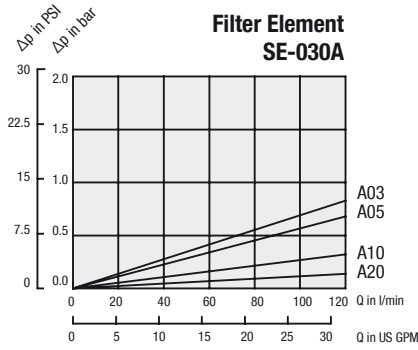
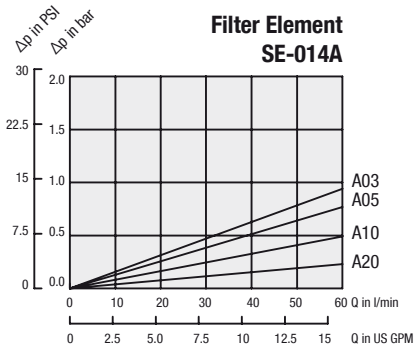

High and Medium Pressure Filters - Type SF / SF-TM / SF-SM / SFA

The following characteristics are valid for mineral oils with a density of 0,85 kg/dm³ and the kinematic viscosity of 30 mm²/s (30 cst). The characteristics have been determined in accordance to ISO 3968. Multipass filter ratings have been obtained in accordance to ISO 16889. Consult STAUFF for details.

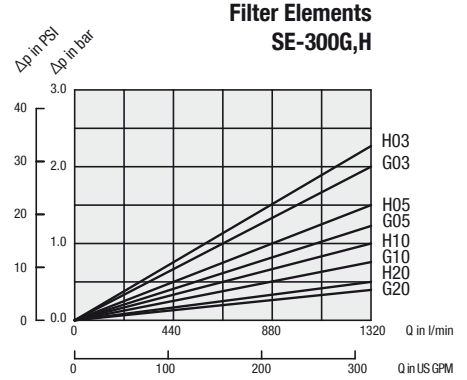
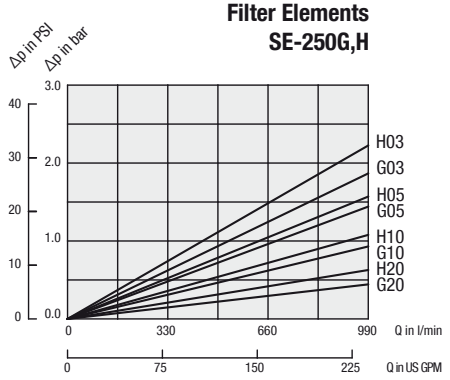
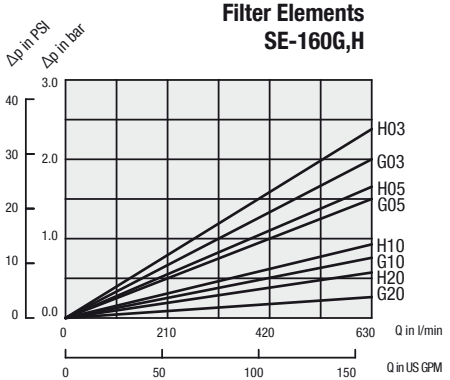
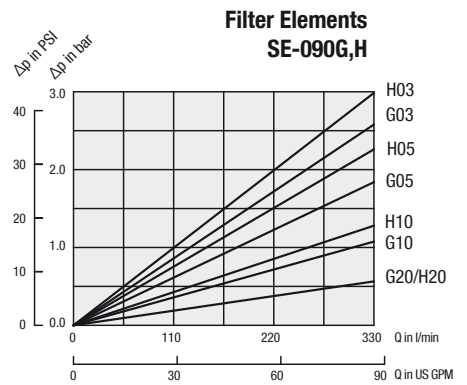
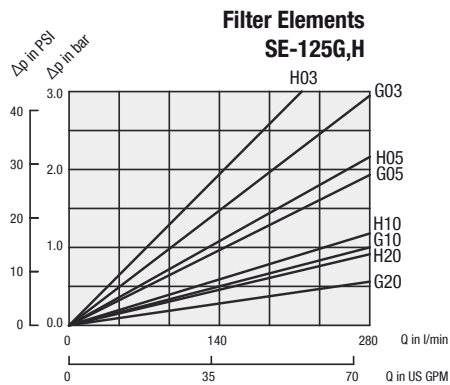
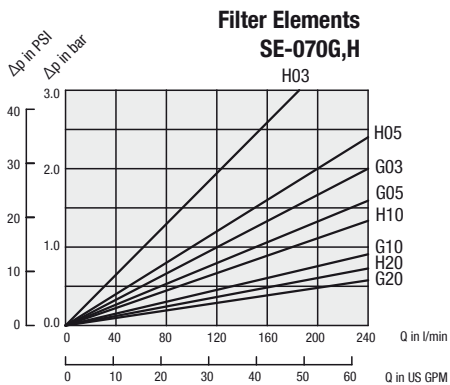
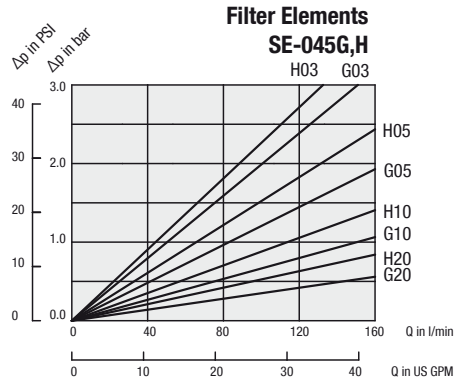
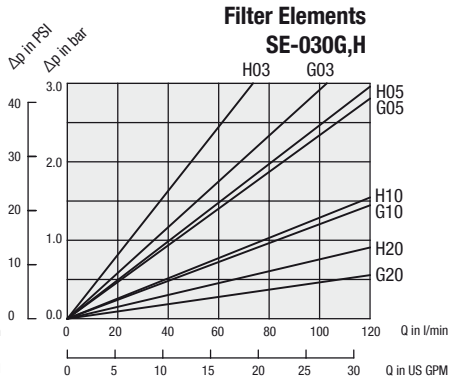
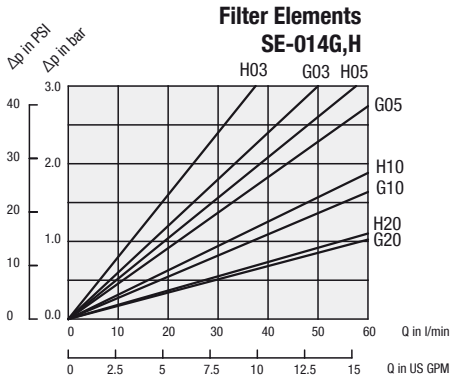

Medium Pressure Filters ■ Type SMPF

Product Description

STAUFF SMPF Medium Pressure Filters are designed for in-line hydraulic applications with a maximum operating pressure of 110 bar / 1600 PSI. Used together with STAUFF Filter Elements, a high efficiency of contamination removal is assured.

Technical Data
Construction

- In-line assembly

Materials

- Filter head: Aluminium Alloy
- Filter bowl: Aluminium Alloy
- Sealings: NBR (Buna-N®)

Port Connections

- BSP
- SAE O-ring thread

Flow Rating

- Up to 90 l/min / 25 US GPM

Operating Pressure

- Max. 110 bar / 1600 PSI

Burst Pressure

- 300 bar / 4350 PSI

Temperature Range

- -25°C ... +110°C / -13°F ... +230°F

Filter Elements

- Specifications see page C44

Media Compatibility

- Mineral oils, other fluids on request

Options and Accessories
Valve

- Bypass valve: Allows unfiltered oil to bypass the contaminated element once the opening pressure has been reached
6 bar / 87 PSI ±10% is the standard actuating pressure

Clogging Indicators

- Standard actuating pressure: 5 bar / 72.5 PSI ±10%
- Available indicators: Visual
Visual-electrical

Medium Pressure Filters ■ Type SMPF

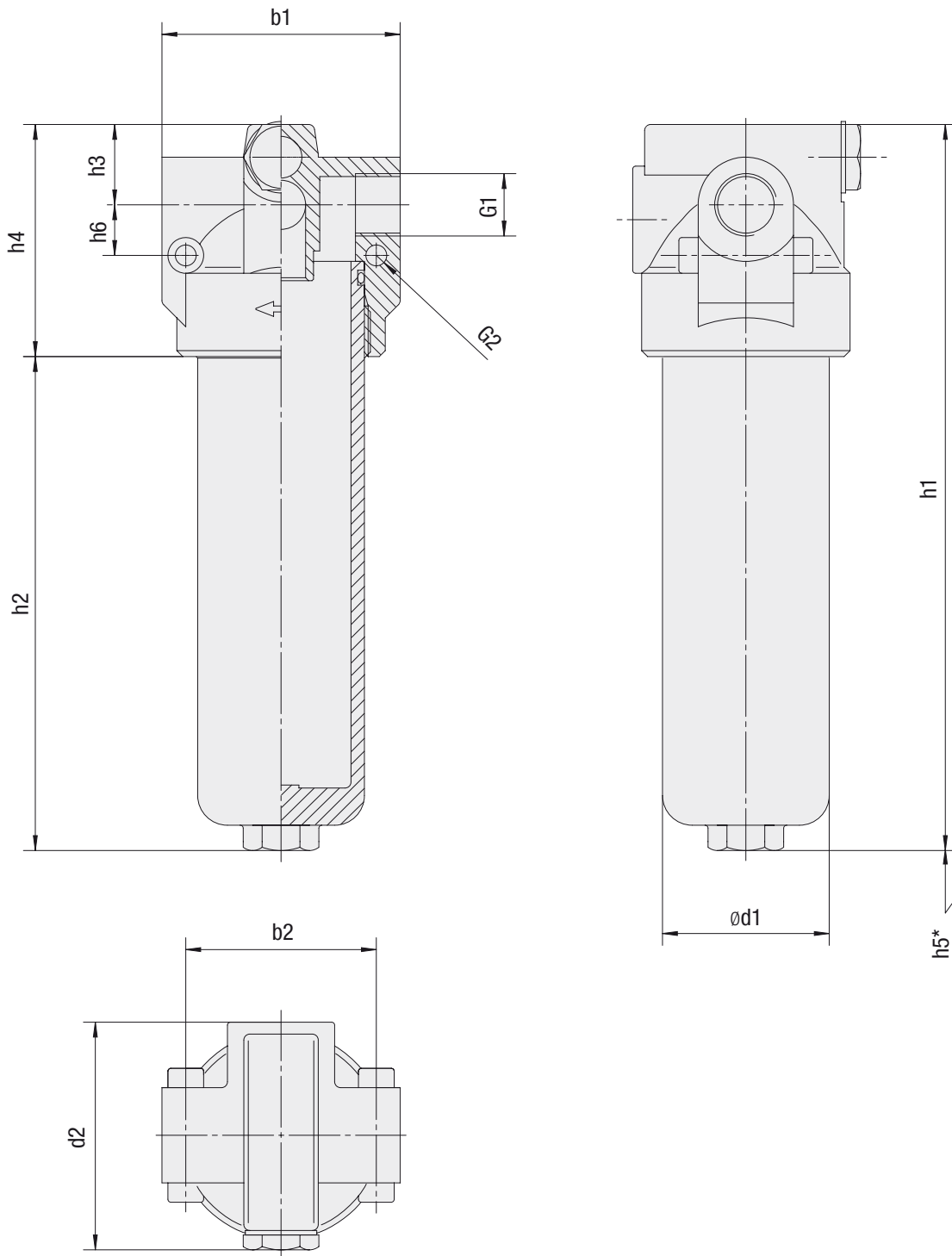

* recommended space for element change

Medium Pressure Filters ■ Type SMPF

Thread Connection G1	Filter Size SMPF	
	015	025
Nominal Flow (l/min / US GPM)	60	90
	15	25
BSP	1/2	1/2
SAE O-ring thread	3/4-16	3/4-16
Weight (kg/lb)	0,95	1,25
	2,09	2,76

Dimensions (mm/in)	Filter Size SMPF	
	015	025
b1	80	80
	3.15	3.15
b2	64	64
	2.52	2.52
d1	56	56
	2.20	2.20
d2	76,5	76,5
	3.01	3.01
h1	157	244
	6.18	9.61
h2	79	166
	3.11	6.54
h3	27	27
	1.06	1.06
h4	78	78
	3.07	3.07
h5	60	60
	2.36	2.36
h6	17	17
	.67	.67
G2	7	7
	.28	.28

Medium Pressure Filter Housings / Complete Filters ■ Type SMPF

SMPF 015 B - T B / B / E / X

1 2 3 4 5 6 7 8 9 10

1 Type

2 Group

Flow	Size
60 l/min / 15 US GPM	015
90 l/min / 25 US GPM	025

Note: Exact flow will depend on filter element selected
Consult technical data on page C46.

3 Filter Material

Material	Max. Δp*collapse	Micron ratings available	Code
Without filter element	-	-	...
Inorg. glass fibre	20 bar / 290 PSI	03, 10, 20	E
Stainless mesh	20 bar / 290 PSI	60	S

* Note: Collapse/burst resistance as per ISO 2941.
Other materials on request.

4 Micron Rating

3 µm	03
10 µm	10
20 µm	20
60 µm	60

Note: Other micron ratings on request.

5 Sealing Material

NBR (Buna®) **B**

Note: Other sealing materials on request.

6 Mounting Style

In-line **T**

7 Connection Style

BSP	1/2	B
SAE O-ring thread	3/4-16	U

8 Valve

Without valve	0
Bypass valve	B

9 Clogging Indicator

Without Clogging Indicator	0
Visual	V
Visual-electrical	VE

10 Design Code

Only for information	X
----------------------	----------

Filter Elements ■ Type SME

SME - 015 E 03 B / X

1 2 3 4 5 6

1 Type

Filter Element Series **SME**

2 Group

According to filter housing

3 Filter Material

Material	Max. Δp*collapse	Micron ratings available	Code
Without filter element	-	-	...
Inorg. glass fibre	20 bar / 290 PSI	03, 10, 20	E
Stainless mesh	20 bar / 290 PSI	60	S

* Note: Collapse/burst resistance as per ISO 2941.
Other materials on request.

4 Micron Rating

3 µm	03
10 µm	10
20 µm	20
60 µm	60

Note: Other micron ratings on request.

5 Sealing Material

NBR (Buna®) **B**

Note: Other sealing materials on request.

6 Design Code

Only for information	X
----------------------	----------

Medium Pressure Filters ■ Type SMPF

Visual Clogging Indicator

Part number HIM-V is a clogging indicator actuated by the differential pressure across the filter element. The actuating pressure of 5 bar / 72.5 PSI allows the dirty element to be changed before the bypass setting of 6 bar / 87 PSI is reached.

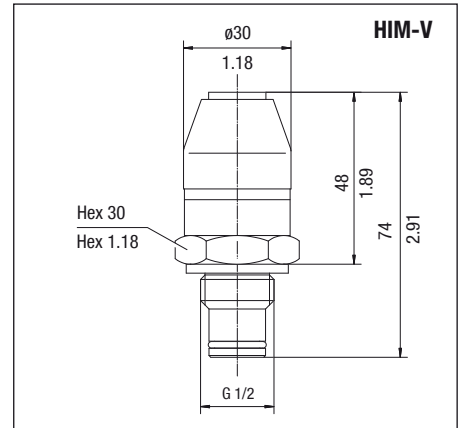
Visual-Electrical Clogging Indicator

Part number HIM-VE is used when an electrical signal is needed to indicate when the element needs changing. It is actuated by the differential pressure across the filter element. The actuating pressure of 5 bar / 72.5 PSI allows the dirty element to be changed before the bypass setting of 6 bar / 87 PSI is reached.

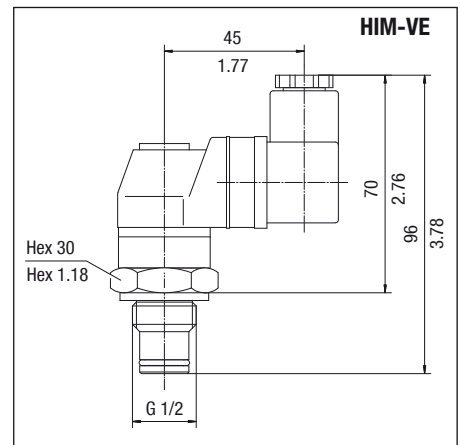

Dimensions in mm / in

HIM-VE Rated Capacity

Voltage V	Resistive Load A	Inductive Load A
125 V AC	5	5
250 V AC	5	5
15 V AC	10	10
30 V DC	5	5
50 V DC	1	1
125 V DC	0.50	0.06

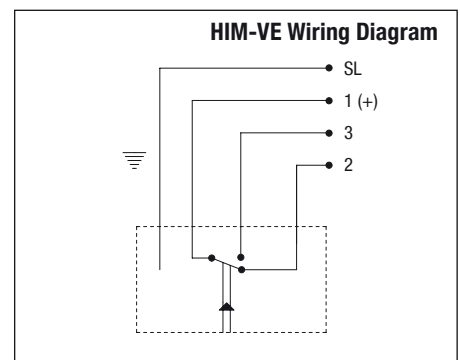
Order Code

HIM - V B - 5,0B / X

1 2 3 4 5

1 Type

Clogging Indicator SMPF Series

HIM
3 Sealing Material

NBR (Buna®)

B
5 Design Code

Only for information

X
2 Indicator Type

Visual

V

Visual-electrical

VE
4 Differential Pressure Setting

5,0 bar / 72.5 PSI

5,0B

Medium Pressure Filters - Type SMPF Flow Characteristics

The following characteristics are valid for mineral oils with a density of 0,85 kg/dm³ and the kinematic viscosity of 30 mm²/s (30 cSt). The characteristics have been determined in accordance to ISO 3968. Multipass filter ratings have been obtained in accordance to ISO 16889. Consult STAUFF for details.

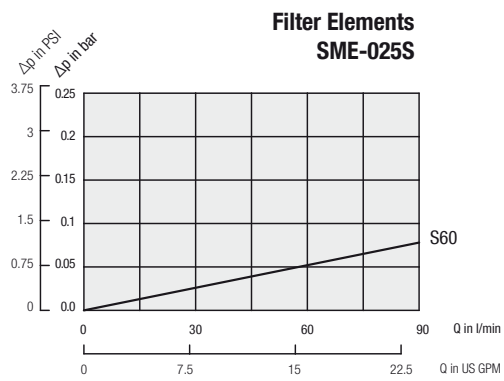
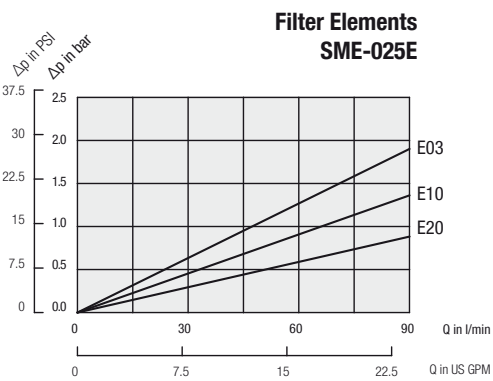
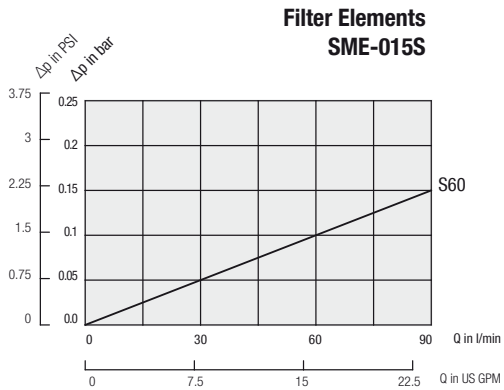
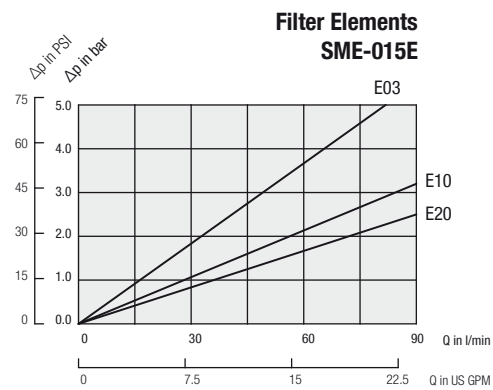
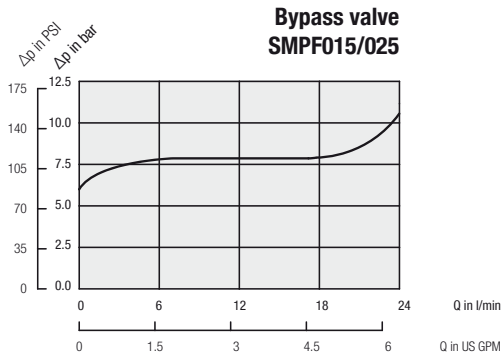
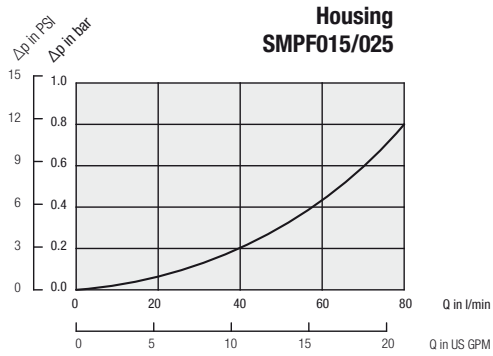

Return Line Filters ■ Type SRFL-S / D

Product Description

STAUFF Return Line Simplex Filters SRFL-S and Duplex Filters SRFL-D are designed for in-line hydraulic applications. With its compact construction and the easy to maintain assembly the SRFL-S and SRFL-D Filters are suitable for flow rates up to 7000 l/min / 1850 US GPM. The two housings of the Duplex Filter SRFL-D are connected with a special gate valve that is operated with a level or hand wheel. Therefore the filter may be serviced without shutting down the hydraulic system. A high efficiency of contaminant removal is assured by using STAUFF RE series Replacement Filter Elements. The high dirt-hold capacity of STAUFF Elements ensures a long service life and, as a result, reduced maintenance costs.

Technical Data
Construction

- In-line assembly, base mounted

Materials

- Filter housing: Carbon Steel
Stainless Steel (on request)
- Sealings: NBR (Buna-N®)
FPM (Viton®)
Other sealing materials on request

Port Connection

- DIN flange
- ANSI flange
- SAE flange

Operating Pressure

- Max. 14 bar / 200 PSI

Flow Rating

- Up to 7000 l/min / 1850 US GPM

Temperature Range

- -10°C ... +100°C / +14°F ... +212°F

Filter Elements

- Specifications see page C59

Media Compatibility

- Mineral oils, lubrication oils, other fluids on request

Options and Accessories
Valve

- Bypass valve: Opening pressure 3 bar ± 0,3 bar / 43.5 PSI ± 4.35 PSI
(integrated in the filter element)
Other settings available on request

Clogging Indicators

- Differential pressure switch, setting 1,6 bar / 23 PSI
Other clogging indicators available on request

Filter Size	Flow l/min/ US GPM	Flange			Filter Element quantity		Arrangement of filter elements	Page
		DIN	ANSI	SAE	SRFL-S	SRFL-D		
SRFL-S/D-160	900/240	DN 40	1-1/2	1-1/2	1x RE-160	2x RE-160		C48/C52
SRFL-S/D-200	900/240	DN 50	2	2	1x RE-200	2x RE-200		
SRFL-S/D-300	1400/370	DN 65	2-1/2	2-1/2	1x RE-300	2x RE-300		
SRFL-S/D-600	1400/370	DN 80	3	3	1x RE-600	2x RE-600		C50/C54
SRFL-S/D-1200	1400/370	DN 100	4	4	2x RE-600	4x RE-600		
SRFL-S/D-1800	4000/1050	DN 125	5	5	3x RE-600	6x RE-600		C50/C56
SRFL-S/D-2400	4000/1050	DN 150	6	6	4x RE-600	8x RE-600		
SRFL-S/D-3600	7000/1850	DN 200	8	8	6x RE-600	12x RE-600		C50/C56

Return Line Filters - Type SRFL-S 160 / 200 / 300 / 600

Detail arrangement of filter elements



SRFL-S 160 / 200 / 300 / 600

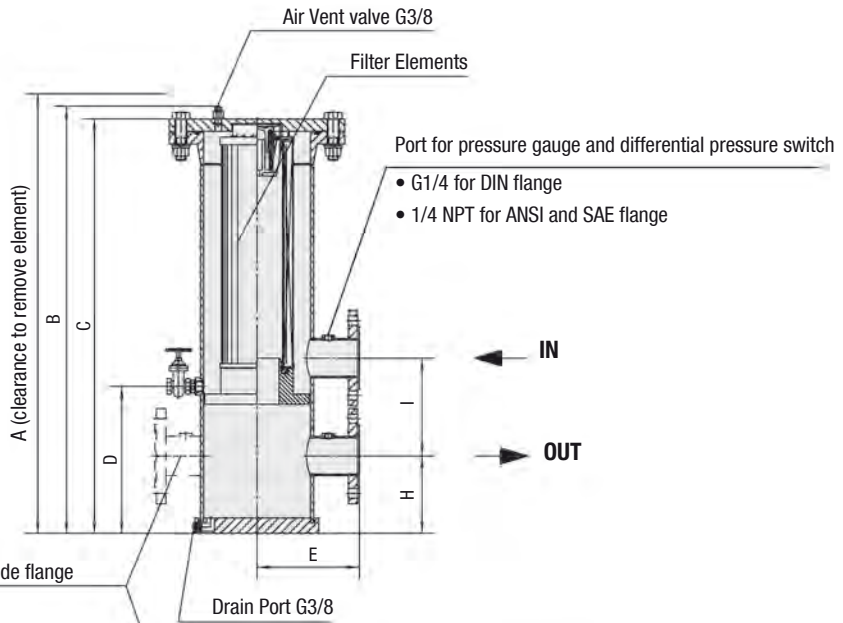
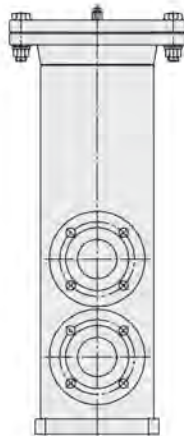

Option: Opposite side flange
see detail

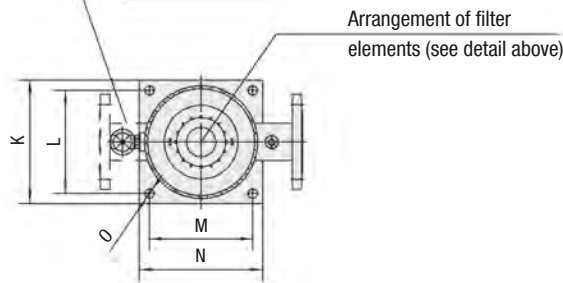

Option: Connection location

S (same side)

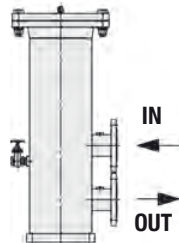

O (opposite side)

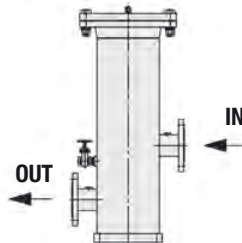

Return Line Filters ■ Type SRFL-S 160 / 200 / 300 / 600

Flange Connection	Filter Size SRFL-S			
	160	200	300	600
DIN	DN 40	DN 50	DN 65	DN 80
ANSI	1-1/2	2	2-1/2	3
SAE	1-1/2	2	2-1/2	3

Dimensions (mm/in)	Filter Size SRFL-S			
	160	200	300	600
A	885,8	1045,8	1248,7	2126,7
	34.87	41.17	49.16	83.73
B	607,6	688,7	828,6	1267,6
	23.92	27.12	32.63	49.91
C	584	664	803,9	1242,9
	22.99	26.14	31.65	48.93
D	214	214	285	285
	8.43	8.43	11.22	11.22
E	148	148	198	198
	5.83	5.83	7.80	7.80
H	130	140	150	160
	5.12	5.51	5.91	6.30
I	155	190	190	220
	6.10	7.48	7.48	8.66
K	150	150	240	240
	5.91	5.91	9.45	9.45
L	125	125	200	200
	4.92	4.92	7.87	7.87
M	125	125	200	200
	4.92	4.92	7.87	7.87
N	150	150	240	240
	5.91	5.91	9.45	9.45
O	11	11	18	18
	.43	.43	.71	.71
Total Oil Capacity (l/gal)	6,0	7,1	22,2	37,1
	1.59	1.86	5.87	9.80
Weight (kg/lbs)	14,5	15,9	29	34,5
	32	35	64	76
Filter Elements	Designation	RE-160 ...	RE-200 ...	RE-300 ...
	Quantity	1 x 1	1 x 1	1 x 1

Return Line Filters - Type SRFL-S 1200 / 1800 / 2400 / 3600

Detail arrangement of filter elements

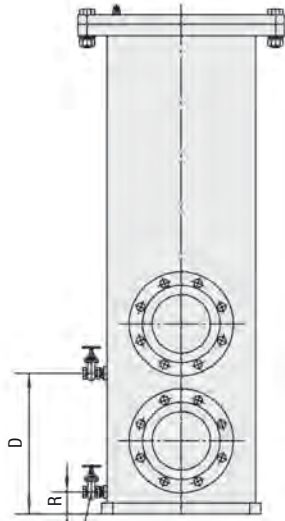

Drain Valve G1/2

Option: Opposite side flange see detail

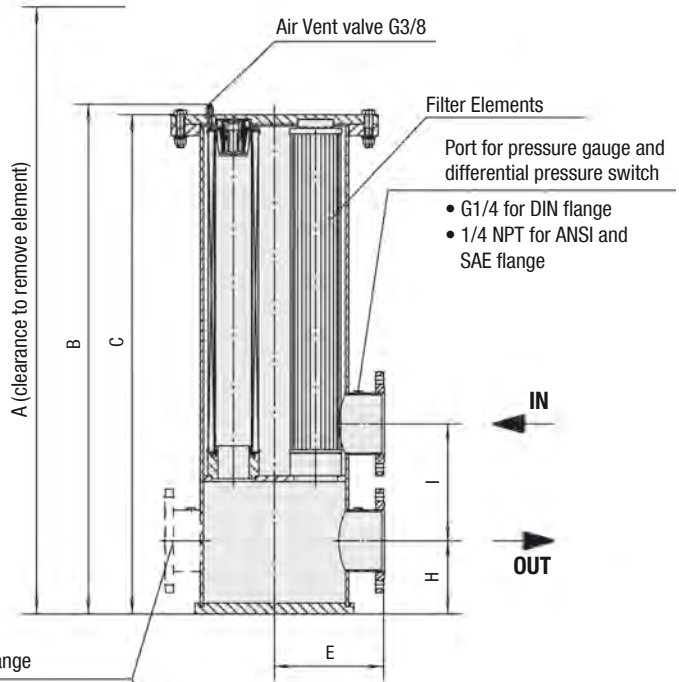

Arrangement of filter elements (see detail above)

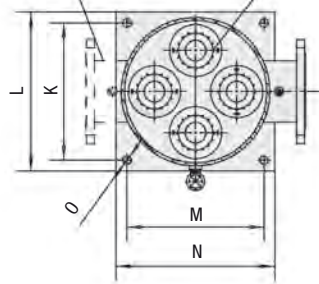

Option: Connection location

S (same side)

O (opposite side)

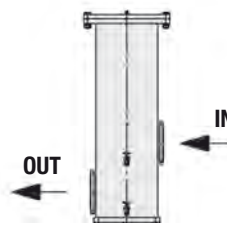

Return Line Filters ■ Type SRFL-S 1200 / 1800 / 2400 / 3600

Flange Connection	Filter Size SRFL-S			
	1200	1800	2400	3600
DIN	DN 100	DN 125	DN 150	DN 200
ANSI	4	5	6	8
SAE	4	5	6	8

Dimensions (mm/in)	Filter Size SRFL-S			
	1200	1800	2400	3600
A	2176,7	2176,7	2249,1	2249,1
	85.70	85.70	88.55	88.55
B	1319,6	1323,6	1394,8	1392,8
	51.96	52.11	54.92	54.84
C	1294,6	1294,9	1366,1	1368,1
	50.98	50.98	53.78	53.86
D	275	275	325	325
	10.83	10.83	12.80	12.80
E	273	273	298	398
	10.75	10.75	11.73	15.67
H	190	190	200	252
	7.48	7.48	7.87	9.92
I	250	280	320	425
	9.84	11.02	12.6	16.73
K	385	385	435	540
	15.16	15.16	17.13	21.26
L	325	325	375	480
	12.80	12.80	14.76	18.90
M	325	325	375	480
	12.80	12.80	14.76	18.90
N	385	385	435	540
	15.16	15.16	17.13	21.26
O	23	23	23	23
	.91	.91	.91	.91
R	60	60	60	60
	2.36	2.36	2.36	2.36
Total Oil Capacity (l/gal)	103	103	149	232
	27.21	27.21	39.37	61.30
Weight (kg/lbs)	86,2	90,7	105,2	154,2
	190	200	232	340
Filter Elements	Designation	RE-600 ...	RE-600 ...	RE-600 ...
	Quantity	1 x 2	1 x 3	1 x 4

Return Line Filters - Type SRFL-D 160 / 200 / 300 / 600

Detail arrangement of filter elements



SRFL-D 160 / 200 / 300 / 600

Detail connecting ports

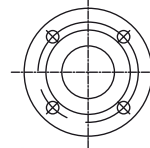

Flange 1-1/2, 2, 2-1/2

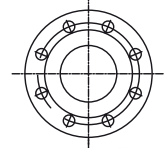

Flange 3

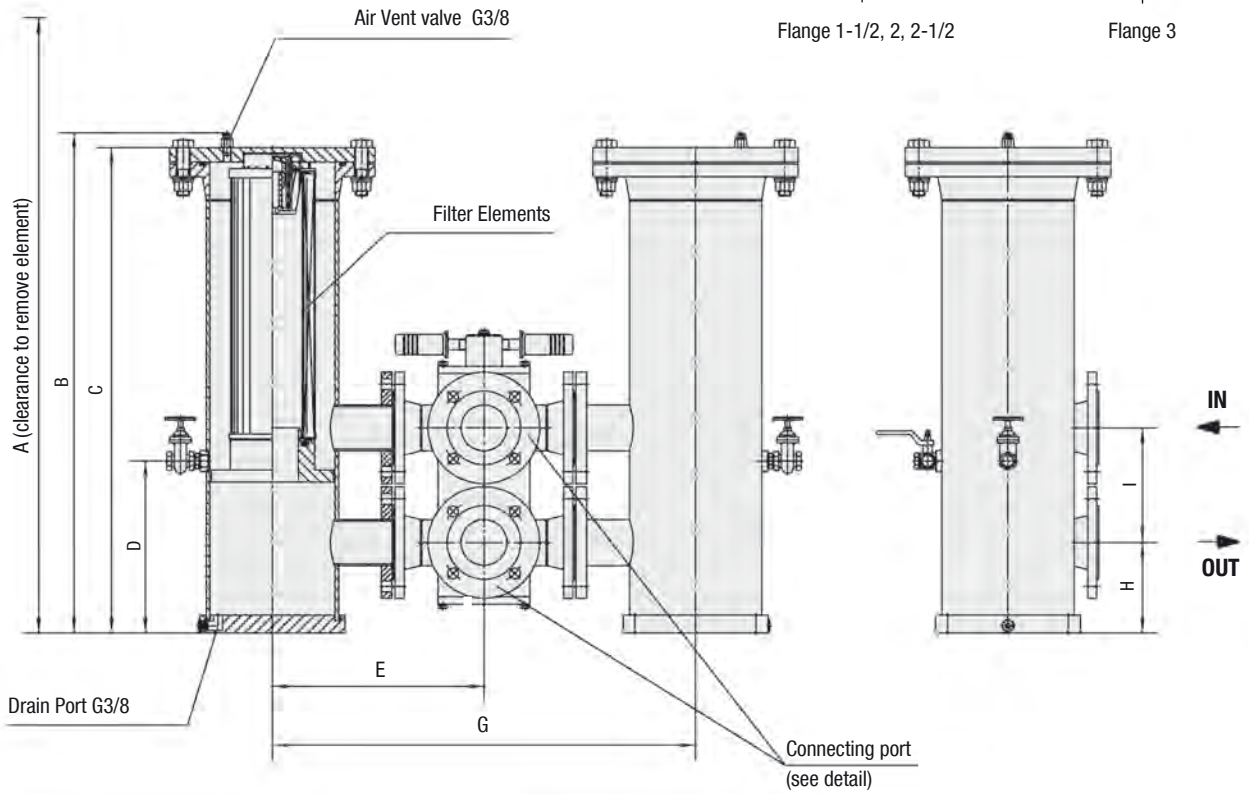

Arrangement of filter elements (see detail above)

Pressure tap
Balance line 1/2"

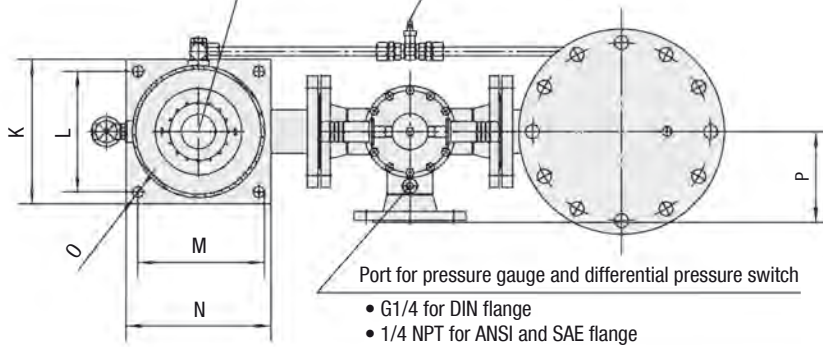

- G1/4 for DIN flange
- 1/4 NPT for ANSI and SAE flange

Return Line Filters ■ Type SRFL-D 160 / 200 / 300 / 600

Flange Connection	Filter Size SRFL-D			
	160	200	300	600
DIN	DN 40	DN 50	DN 65	DN 80
ANSI	1-1/2	2	2-1/2	3

Dimensions (mm/in)	Filter Size SRFL-D				
	160	200	300	600	
A	885,8	1045,8	1248,7	2126,7	
	34.87	41.17	49.16	83.73	
B	607,6	688,7	828,6	1267,6	
	23.92	27.12	32.63	49.91	
C	584	642	803,9	1242,9	
	22.99	25.28	31.65	48.93	
D	214	214	285	285	
	8.43	8.43	11.22	11.22	
E	260	300	350	375	
	10.24	11.81	13.78	14.76	
G	520	600	700	750	
	20.47	23.62	27.56	29.53	
H	130	140	150	160	
	5.12	5.51	5.91	6.30	
I	155	190	190	220	
	6.10	7.48	7.48	8.66	
K	150	150	240	240	
	5.91	5.91	9.45	9.45	
L	125	125	200	200	
	4.92	4.92	7.87	7.87	
M	125	125	200	200	
	4.92	4.92	7.87	7.87	
N	150	150	240	240	
	5.91	5.91	9.45	9.45	
O	11	11	18	18	
	.43	.43	.71	.71	
P	110	150	150	175	
	4.33	5.91	5.91	6.89	
Total Oil Capacity (l/gal)	6	7,1	22,2	37,1	
	1.59	1.86	5.87	9.80	
Weight (kg/lbs)	43	56,7	84	104	
	95	125	185	230	
Filter Elements	Designation	RE-160 ...	RE-200 ...	RE-300 ...	RE-600 ...
	Quantity	2 x 1	2 x 1	2 x 1	2 x 1

Return Line Filters - Type SRFL-D 1200 / 1800 / 2400

Detail arrangement of filter elements

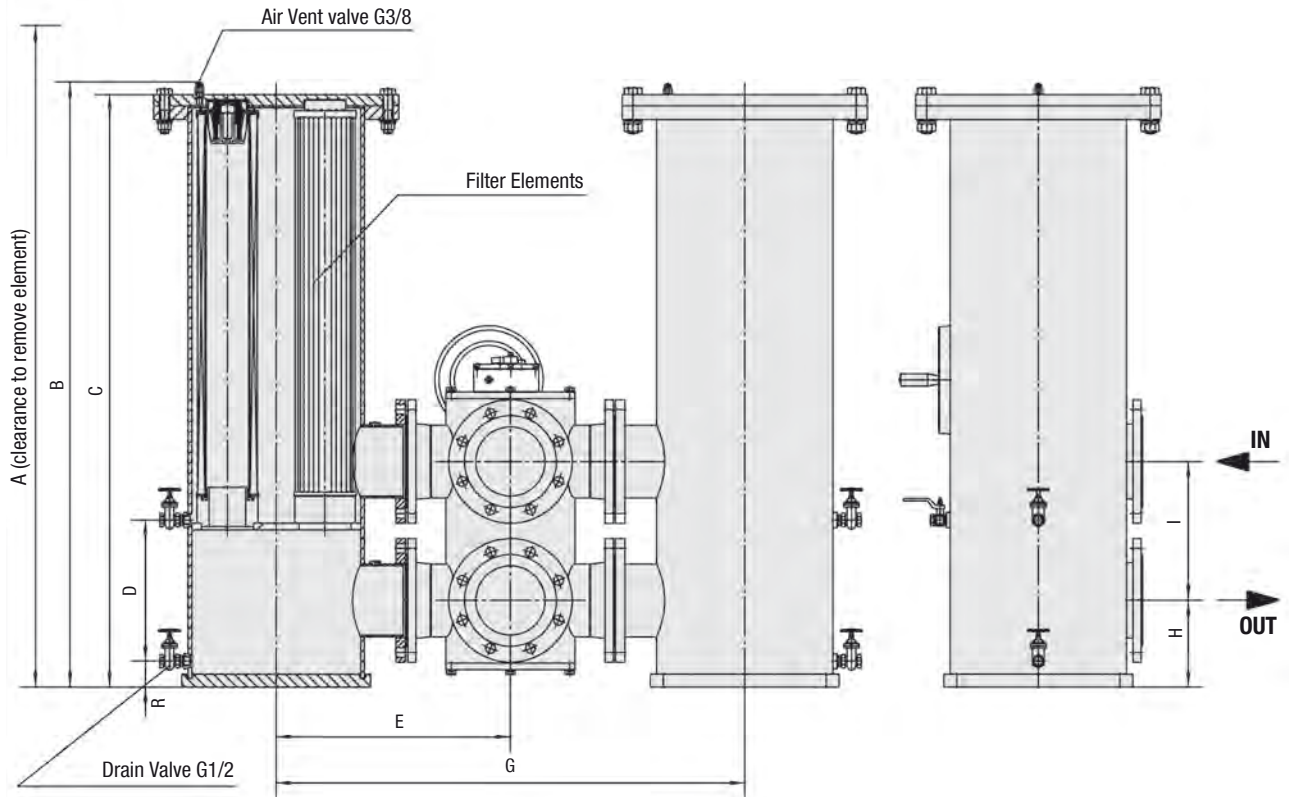

Arrangement of filter elements (see detail above)

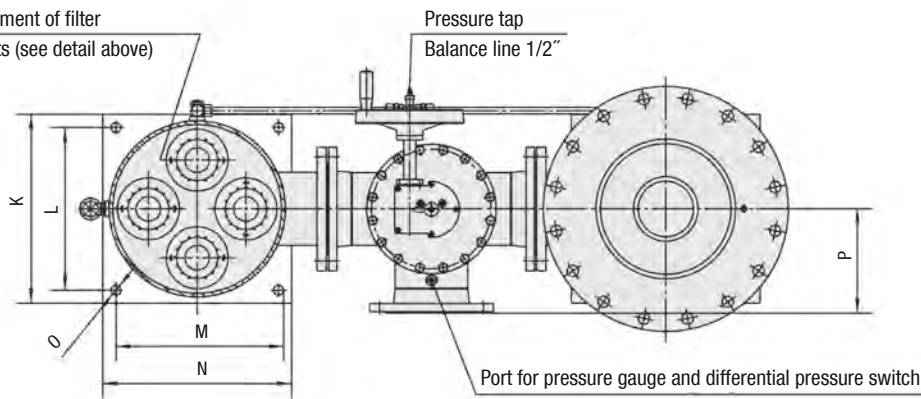

Port for pressure gauge and differential pressure switch

- G1/4 for DIN flange
- 1/4 NPT for ANSI and SAE flange

Return Line Filters ■ Type SRFL-D 1200 / 1800 / 2400

Flange Connection	Filter Size SRFL-D		
	1200	1800	2400
DIN	DN 100	DN 125	DN 150
ANSI	4	5	6

Dimensions (mm/in)	Filter Size SRFL-D		
	1200	1800	2400
A	2176,7	2176,7	2249,1
	85.70	85.70	88.55
B	1319,6	1323,6	1394,8
	51.96	52.11	54.92
C	1294,9	1294,9	1366,1
	50.98	50.98	53.78
D	275	275	325
	10.83	10.83	12.80
E	475	500	540
	18.70	19.69	21.26
G	950	1000	1080
	37.40	39.37	42.52
H	190	190	200
	7.48	7.48	7.87
I	250	280	320
	9.84	11.02	12.60
K	385	385	435
	15.16	15.16	17.13
L	325	325	375
	12.80	12.80	14.76
M	325	325	375
	12.80	12.80	14.76
N	385	385	435
	15.16	15.16	17.13
O	23	23	23
	.91	.91	.91
P	200	225	240
	7.87	8.86	9.45
R	60	60	60
	2.36	2.36	2.36
Total Oil Capacity (l/gal)	103	103	149
	27.20	27.20	39.30
Weight (kg/lbs)	215	233	263
	475	515	580
Filter Elements	Designation	RE-600 ...	RE-600 ...
	Quantity	2 x 2	2 x 3

Return Line Filters - Type SRFL-D 3600

Detail arrangement of filter elements

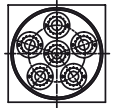

SRFL-D 3600

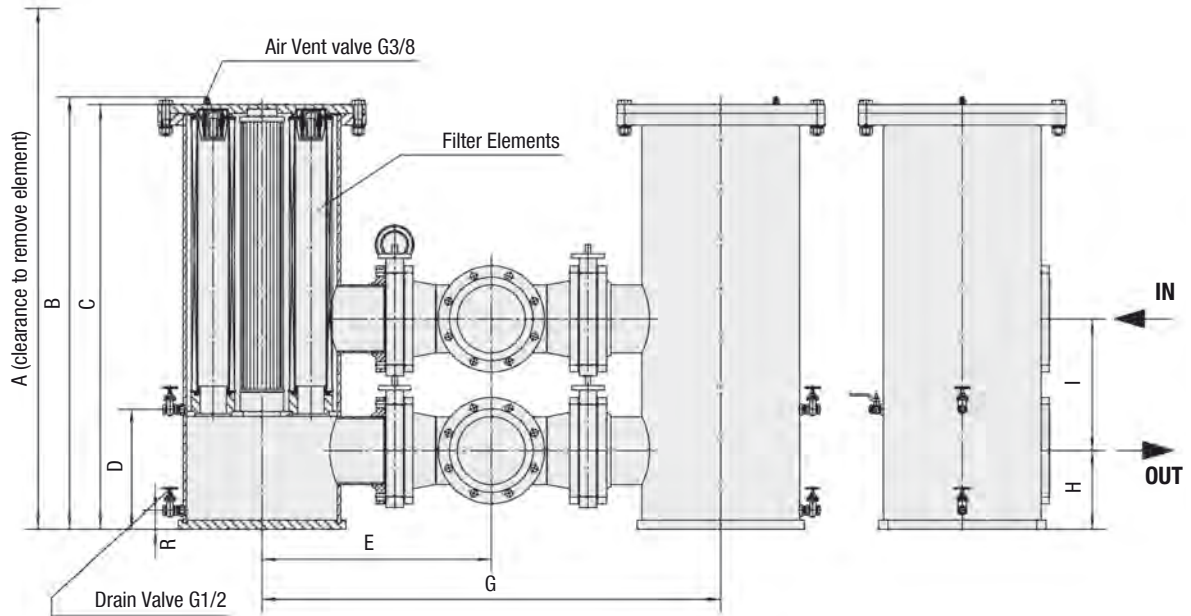

Arrangement of filter elements (see detail above)

Pressure tap
Balance line 1/2"

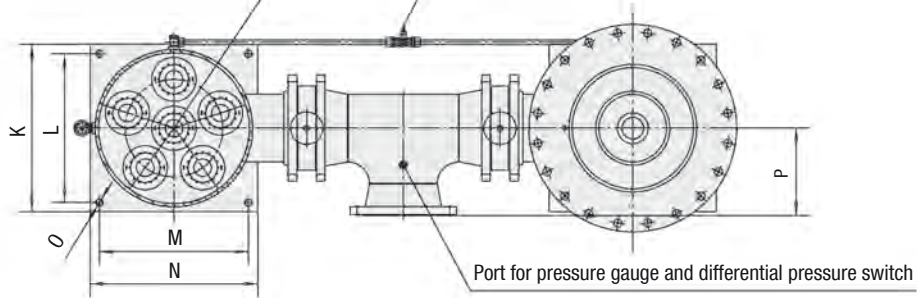

- G1/4 for DIN flange
- 1/4 NPT for ANSI and SAE flange

Return Line Filters ▪ Type SRFL-D 3600

Flange Connection	Filter Size SRFL-D
	3600
DIN	DN 200
ANSI	8

Dimensions (mm/in)	Filter Size SRFL-D	
	3600	
A	2249,1 88.55	
B	1392,8 54.84	
C	1368,1 53.86	
D	325 12.80	
E	739 29.11	
G	1479 58.22	
H	252 9.92	
I	425 16.73	
K	540 21.26	
L	480 18.90	
M	480 18.90	
N	540 21.26	
O	23 .91	
P	281,4 11.08	
R	60 2.36	
Total Oil Capacity (l/gal)	233 61.3	
Weight (kg/lbs)	390 860	
Filter Elements	Designation	RE-600 ...
	Quantity	2 x 6

Return Line Filter Housings / Complete Filters ■ Type SRFL-S / D

SRFL - D - 160 B / A / 0 / CS / D / X
1 2 3 4 5 6 7 8 9 10
1 Type

Return Line Simplex Housing	SRFL-S
Return Line Duplex Housing	SRFL-D

2 Group

Flow	Size
900 l/min / 240 US GPM	160
900 l/min / 240 US GPM	200
1400 l/min / 370 US GPM	300
1400 l/min / 370 US GPM	600
1400 l/min / 370 US GPM	1200
4000 l/min / 1050 US GPM	1800
4000 l/min / 1050 US GPM	2400
7000 l/min / 1850 US GPM	3600

3 Filter Material

Material	Max. Δp^* collapse	Micron ratings available	Code
Without filter element	-	-	...
Inorg. glass fibre	25 bar / 363 PSI	3, 5, 10, 20	G
Stainless fibre	30 bar / 435 PSI		A
Filter paper	10 bar / 145 PSI	10, 20	N
Stainless mesh	30 bar / 435 PSI	25, 50, 100, 200	S

* Note: Collapse/burst resistance as per ISO 2941.
Other materials on request.

4 Micron Rating

3 μm	03
5 μm	05
10 μm	10
20 μm	20
25 μm	25
50 μm	50
100 μm	100
200 μm	200

Note: Other micron ratings on request.

5 Sealing Material

NBR (Buna®)	B
FPM (Viton®)	V

Note: Other sealing materials on request.

6 Connection Style

Connection Style	Group								Code
	160	200	300	600	1200	1800	2400	3600	
DIN Flange	DN 40	DN 50	DN 65	DN 80	DN 100	DN 125	DN 150	DN 200	D
ANSI Flange	1-1/2	2	2-1/2	3	4	5	6	8	A
SAE Flange	1-1/2	2	2-1/2	3	4	5	6	8	S

Note: SAE flange is not available for SRFL-D.

7 Connection Location

Opposite side*	0
Same side	S

* Note: Omit for SRFL-D series

8 Housing Material

Carbon Steel	CS
Stainless Steel	SS

9 Clogging Indicator

Without Clogging Indicator	0
Differential Pressure Switch with Visual Gauge Indicator	D

Note: Other indicators on request. See page C59.

10 Design Code

Only for information	X
----------------------	----------

Filter Elements ■ Type RE

RE - 160 G 10 B / X
1 2 3 4 5 6
1 Type

Filter Element Series	RE
-----------------------	-----------

2 Group

Designation	Filter Element Quantity		Size
	SRFL-S	SRFL-D	
RE-160	1x1	2x1	160
RE-200	1x1	2x1	200
RE-300	1x1	2x1	300
RE-600	1x1	2x1	600
RE-600	1x2	2x2	1200
RE-600	1x3	2x3	1800
RE-600	1x4	2x4	2400
RE-600	1x6	2x6	3600

3 Filter Material

Material	Max. Δp^* collapse	Micron ratings available	Code
Inorg. glass fibre	25 bar / 363 PSI	3, 5, 10, 20	G
Stainless fibre	30 bar / 435 PSI		A
Filter paper	10 bar / 145 PSI	10, 20	N
Stainless mesh	30 bar / 435 PSI	25, 50, 100, 200	S

* Note: Collapse/burst resistance as per ISO 2941.
Other materials on request.

4 Micron Rating

3 μm	03
5 μm	05
10 μm	10
20 μm	20
25 μm	25
50 μm	50
100 μm	100
200 μm	200

Note: Other micron ratings on request.

5 Sealing Material

NBR (Buna®)	B
FPM (Viton®)	V

Note: Other sealing materials on request

6 Design Code

Only for information	X
----------------------	----------

Return Line Filters - Type SRFL-S / D

Filter Elements and Clogging Indicator

Product Description

STAUFF Replacement Filter Elements for SRFL-S and SRFL-D Series Filters are manufactured in the common filter materials such as Stainless Fibre, Stainless Mesh, Cellulose and Inorganic Glass Fibre. As standard all Replacement Elements series RE have tin plated steel parts for use with aggressive media such as water glycol, upon request you also can get other materials. All Replacement Elements made by STAUFF comply with quality specifications in accordance with international standards.

Order Code
RE - 160 G 10 B / X

1 2 3 4 5 6

1 Type

 Filter Element Series **RE**
2 Group

 According to filter housing
 Note: See order code page C58

3 Filter Material

Material	Max. Δp *collapse	Micron ratings available	Code
Inorg. glass fibre	25 bar / 363 PSI	3, 5, 10, 20	G
Stainless fibre	30 bar / 435 PSI		A
Filter paper	10 bar / 145 PSI	10, 20	N
Stainless mesh	30 bar / 435 PSI	25, 50, 100, 200	S

* Note: Collapse/burst resistance as per ISO 2941.
 Other materials on request.

4 Micron Rating

3 μm	03
5 μm	05
10 μm	10
20 μm	20
25 μm	25
50 μm	50
100 μm	100
200 μm	200

Note: Other micron ratings on request.

5 Sealing Material

 NBR (Buna®) **B**
 FPM (Viton®) **V**
 Note: Other sealing materials on request.

6 Design Code

 Only for information **X**
Differential Pressure Switch with Visual Gauge Indicator

The switch is used to indicate when the elements need changing. The switch can turn on a light, shut down the machine or any further function controlled by an electrical signal. The gauge visually indicates the differential pressure across the filter elements.

Diameter

- 100 mm / 3.94 in

Scale

- 0 ... 1,6 kg/cm²

Connection Thread

- G1/4

Operating Pressure

- Max. 200 bar / 2900 PSI

Temperature Range

- 20 °C ... +80 °C / -4 °F ... +176 °F

Materials

- Body: Aluminium
- Lens: Glass
- Sealing Material: NBR (Buna-N®)
FPM (Viton®)

Protection Rating

- IP 65: Dust tight and protected against water jets.

Switch Voltage

- Max. 28 V AC/DC

Current On Contact

- Max. 0,25 A

Contact Rating

- 5 VA AC/DC

Return Line Filters - Type SRFL-S / D Flow Characteristics

The following characteristics are valid for mineral oils with a density of 0,85 kg/dm³ and the kinematic viscosity of 30 mm²/s (30cSt). The characteristics have been determined in accordance to ISO 3968. Multipass filter ratings have been obtained in accordance to ISO 16889. The housing pressure drop is directly proportional to the oil density. Consult STAUFF for details.

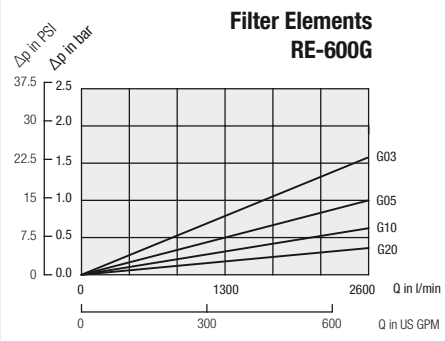
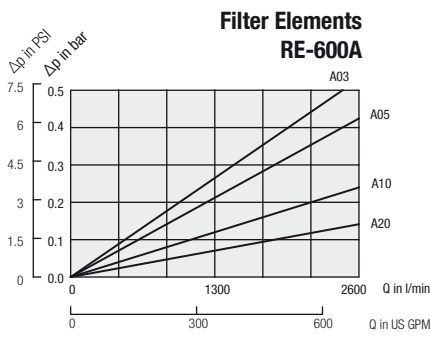
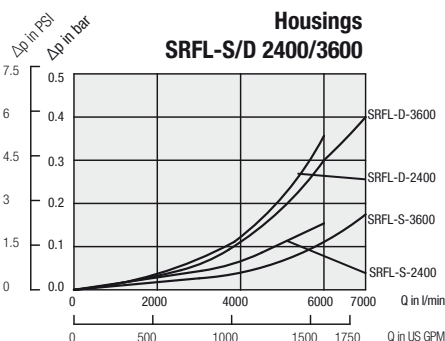
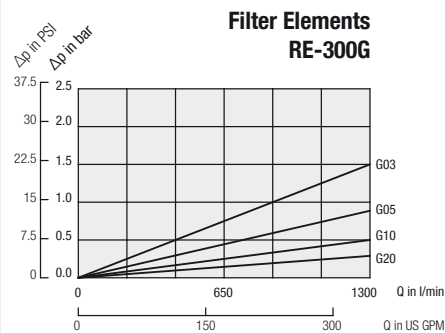
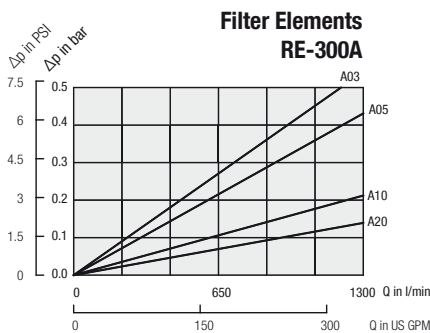
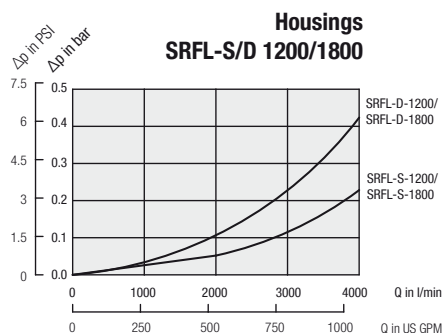
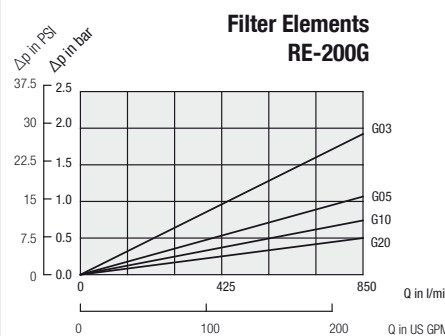
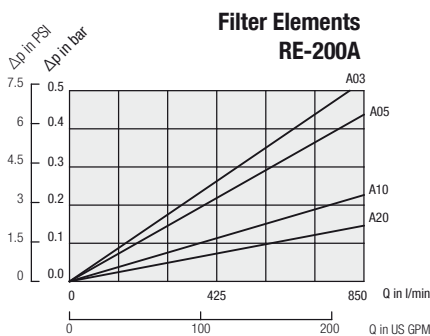
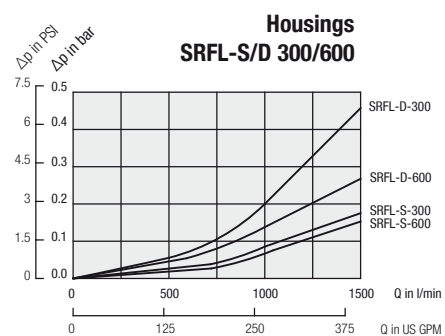
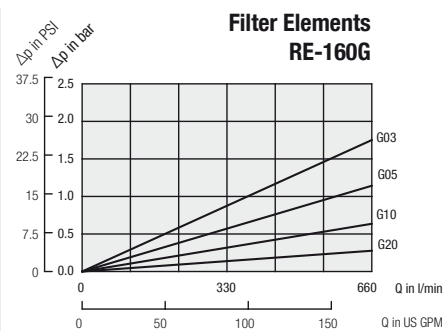
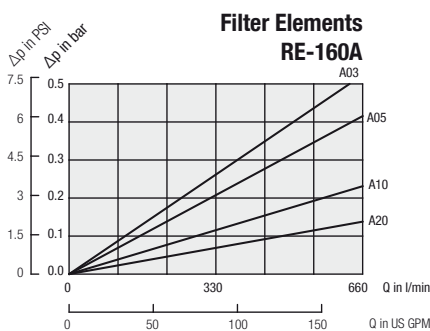
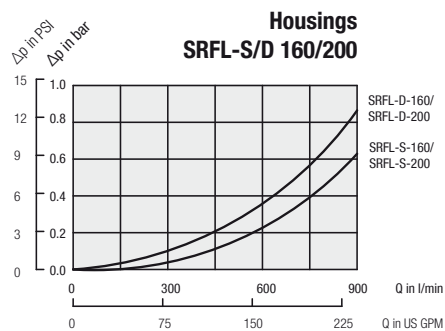

Pressure drop of housing including filter elements

General: $\Delta p_{total} = \Delta p_{housing} + \Delta p_{Element} \times (\text{operating viscosity [mm}^2\text{/s]} / 30\text{mm}^2\text{/s})$

with $\Delta p_{housing}$ = See diagrams above

$\Delta p_{Element}$ = pressure drop of element at a flow Q/n (at a viscosity of 30 mm²/s and n = numbers of elements as listed in ordering code filter elements see page C58 and diagrams above.)

Example

Data given Q_{max} = 6000 l/min / 1585 US GPM, SRFL-D-2400 with filter elements RE-600S25B;
operating viscosity = 100 mm²/s
 Q_{max} = 6000 l/min; n=4 elements (SRFL-D-2400) Q/n =1500 l/min / 396 gal
 $\Delta p_{housing}$ = 0,35 bar / 5.07 PSI, $\Delta p_{Element}$ = 0,03 bar / 0.44 PSI

Pressure drop: $\Delta p_{total} = 0,35 \text{ bar} + 0,03 \text{ bar} \times (100 \text{ mm}^2\text{/s} / 30\text{mm}^2\text{/s})$
= 0,45 bar / 6.53 PSI

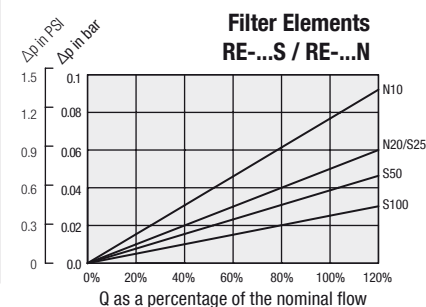

Return Line Filters ▪ Type RF

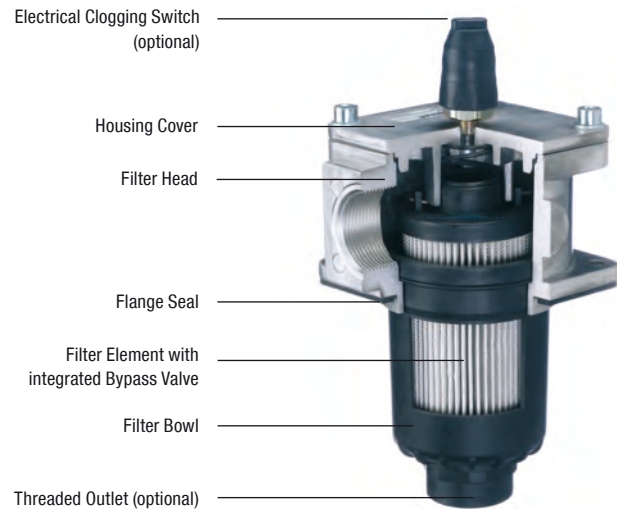
Product Description

STAUFF RF Return Line Filters are designed as tank top filters. They are mounted directly on the tank top and when 100% of the system's oil is filtered they provide the optimum removal of contaminant from the system. This provides the pump with clean oil thus reducing contaminant generated wear. The filter bowl is designed to return the oil beneath the surface thus preventing the entrainment of air by the returning oil. A high efficiency of contaminant removal is assured by using STAUFF RE Replacement Filter Elements. The high dirt-hold capacity of STAUFF Elements ensures a long service life and as a result reduced maintenance costs.

Technical Data
Construction

- Tank Top flange mounting

Materials

- Filter head: Aluminium
- Filter bowl: Glass Fibre reinforced Polyamide
- Sealings: NBR (Buna-N®)
FPM (Viton®)
EPDM (Ethylene-Propylene-Diene-Monomer-Rubber)
Other sealing materials on request

Port Connection

- BSP
- NPT
- SAE O-ring thread
- SAE flange 3000 PSI

Operating Pressure

- Max. 16 bar / 232 PSI

Temperature Range

- -10°C ... +100°C / +14°F ... +212°F

Filter Elements

- Specifications see page C64

Media Compatibility

- Mineral oils, other fluids on request

Options and Accessories
Valve

- Bypass valve (integrated in the filter element) Opening pressure 3 bar \pm 0,3 bar / 43.5 PSI \pm 4.35 PSI
Other settings available on request

Clogging Indicators

- Visual clogging indicator 0 ... 4 bar / 0 ... 58 PSI coloured segments
- Electrical clogging switch, setting 2,5 bar / 36.25 PSI
Other clogging indicators available on request

Return Line Filters - Type RF

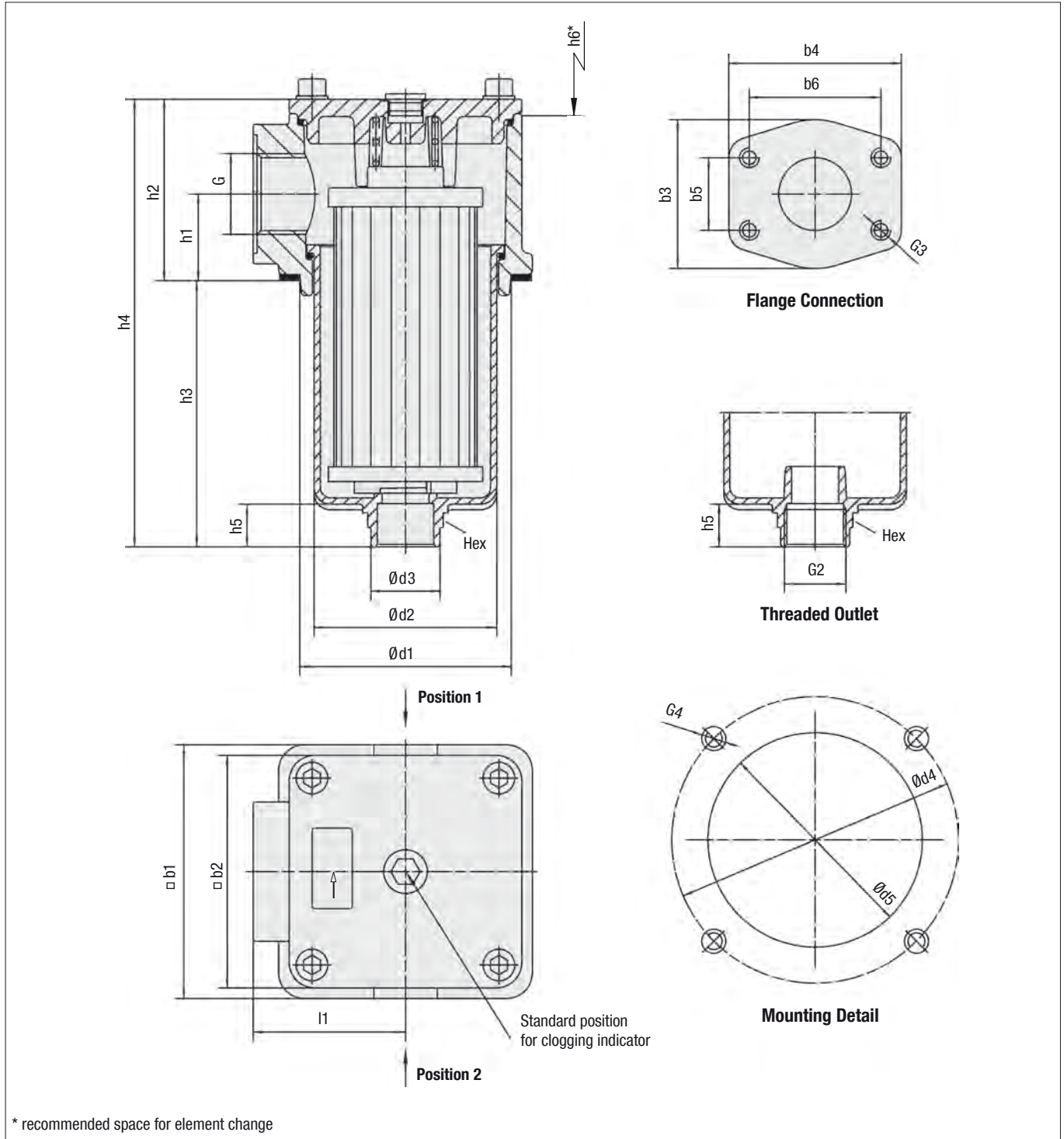

Return Line Filters ■ Type RF

Thread Connection G	Filter Size RF					
	014	030	045	070	090	130
BSP	3/4	1	1-1/4	1-1/2	2	2
NPT	3/4	1	1-1/4	1-1/2	2	2
SAE O-ring Thread	1-1/16-12	1-5/16-12	1-5/8-12	1-7/8-12	1-7/8-12	1-7/8-12
SAE Flange 3000 PSI	-	-	-	-	2	2

Dimensions (mm/in)	Filter Size RF					
	014	030	045	070	090	130
b1	89	89	120	120	150	150
	3.50	3.50	4.72	4.72	5.91	5.91
b2	80	80	110	110	135	135
	3.15	3.15	4.33	4.33	5.31	5.31
b3	-	-	-	-	88	88
	-	-	-	-	3.47	3.47
b4	-	-	-	-	102	102
	-	-	-	-	4.02	4.02
b5	-	-	-	-	42,9	42,9
	-	-	-	-	1.69	1.69
b6	-	-	-	-	77,8	77,8
	-	-	-	-	3.06	3.06
d1	73	73	100	100	126	126
	2.87	2.87	3.94	3.94	4.96	4.96
d2	57,5	57,5	84	84	112,5	112,5
	2.26	2.26	3.31	3.31	4.43	4.43
d3	36	36	48	48	54,5	54,5
	1.42	1.42	1.89	1.89	2.15	2.15
d4	100	100	135	135	170	170
	3.94	3.94	5.31	5.31	6.69	6.69
d5	78	78	105	105	131	131
	3.07	3.07	4.13	4.13	5.16	5.16
h1	33	33	41	41	47	47
	1.30	1.30	1.61	1.61	1.85	1.85
h2	66	66	86	86	98	98
	2.60	2.60	3.39	3.39	3.86	3.86
h3	91,5	159,5	119	180	172,5	252,5
	3.60	6.28	4.69	7.09	6.79	9.94
h4	157,5	225,5	206	267	273,5	353,5
	6.20	8.88	8.11	10.51	10.77	13.91
h5	23,5	23,5	24	24	27	27
	.93	.93	.95	.95	1.06	1.06
h6	140	210	180	240	235	315
	5.51	8.27	7.09	9.45	9.25	12.40
l1	48	48	66	66	85	85
	1.89	1.89	2.60	2.60	3.35	3.35
G2	G1 or 1 NPT	G1 or 1 NPT	G1-1/4 or 1-1/4 NPT	G1-1/4 or 1-1/4 NPT	G1-1/2 or 1-1/2 NPT	G1-1/2 or 1-1/2 NPT
G3	-	-	-	-	1/2 UNC x 15 1/2 UNC x .59	1/2 UNC x 15 1/2 UNC x .59
G4	M6 or 1/4-20 UNC	M6 or 1/4-20 UNC	M8 or 5/16-18 UNC	M8 or 5/16-18 UNC	M10 or 3/8-16 UNC	M10 or 3/8-16 UNC
Hex	36	36	50	50	55	55
	1.42	1.42	1.97	1.97	2.16	2.16

Return Line Filter Housings / Complete Filters ■ Type RF

RF **070** **...** **...** **B** / **B** / **M** / **G** / **L1** / **X**

1 2 3 4 5 6 7 8 9 10

1 Type

Return Line Filter **RF**

2 Group

Flow	Size
60 l/min / 14 US GPM	014
110 l/min / 30 US GPM	030
160 l/min / 45 US GPM	045
240 l/min / 70 US GPM	070
330 l/min / 90 US GPM	090
500 l/min / 130 US GPM	130

Note: Exact flow will depend on filter element selected.
Consult technical data on pages C66 / C67.

3 Filter Material

Material	max. Δp^* collapse	Micron ratings available	Code
Without filter element	-	-	...
Inorg. glass fibre	25 bar / 363 PSI	3, 5, 10, 20	G
Stainless fibre	30 bar / 435 PSI	3, 5, 10, 20	A
Filter paper	10 bar / 145 PSI	10, 20	N
Stainless mesh	30 bar / 435 PSI	25, 50, 100, 200	S

Note: *Collapse/burst resistance as per ISO 2941. Other materials on request.

4 Micron Rating

3 μ m	03
5 μ m	05
10 μ m	10
20 μ m	20
25 μ m	25
50 μ m	50
100 μ m	100
200 μ m	200

Note: Other micron ratings on request.

5 Sealing Materials

NBR (Buna®)	B
FPM (Viton®)	V
EPDM	E

Note: Other sealing materials on request

6 Connection Style

Connection Style	Group						Code
	014	030	045	070	090	130	
BSP	3/4	1	1-1/4	1-1/2	2	2	B
BSP	1/2	1/2	1-1/2	1-1/4	1-1/4	1-1/4	B1
BSP	1	3/4	-	-	1-1/2	1-1/2	B2
NPT	3/4	1	1-1/4	1-1/2	2	2	N
NPT	1	3/4	1-1/2	1-1/4	1-1/2	1-1/2	N1
SAE O-ring Thread	1-1/16	1-5/16	1-5/8	1-7/8	1-7/8	1-7/8	U
SAE O-ring Thread	1-5/16	1-1/16	1-7/8	1-5/8	1-5/8	1-5/8	U1
SAE Flange 3000 PSI	-	-	-	-	2	2	F

Note: Bold types identify preferred connection styles.

7 Clogging Indicator

	Position*		
Without Clogging Indicator	-	-	O
Visual Clogging Indicator	-	-	M
Electrical Clogging Switch 42 V, NO	1	2	G42NO
Electrical Clogging Switch 42 V, NC			G42NC
Electrical Clogging Switch 110 V			G110
Electrical Clogging Switch 230 V			G230

Note: *Position of clogging indicator see page C62.
Without any code: assembly in the middle of the filter cover.

8 Outlet Style

Standard outlet (without thread)	O
Filter bowl with threaded outlet	G

9 Additional Features

	Position*		
Without leakage oil connection	-	-	none
Leakage oil connection	1	2	L

Note: *Position of the leakage oil connection see page C62
Without any code: assembly in the middle of the filter cover.

10 Design Code

Only for information	X
----------------------	----------

Filter Elements ■ Type RE

RE - **014** **G** **10** **B** / **X**

1 2 3 4 5 6

1 Type

Filter Element Series **RE**

2 Group

According to filter housing

3 Filter Material

Material	Max. Δp^* collapse	Micron ratings available	Code
Inorg. glass fibre	25 bar / 363 PSI	3, 5, 10, 20	G
Stainless fibre	30 bar / 435 PSI	3, 5, 10, 20	A
Filter paper	10 bar / 145 PSI	10, 20	N
Stainless mesh	30 bar / 435 PSI	25, 50, 100, 200	S

Note: *Collapse/burst resistance as per ISO 2941. Other materials on request.

4 Micron Rating

3 μ m	03
5 μ m	05
10 μ m	10
20 μ m	20
25 μ m	25
50 μ m	50
100 μ m	100
200 μ m	200

Note: Other micron ratings on request.

5 Sealing Materials

NBR (Buna®)	B
FPM (Viton®)	V
EPDM	E

Note: Other sealing materials on request.

6 Design Code

Only for information	X
----------------------	----------

Return Line Filters ■ Type RF

Visual Clogging Indicator

The gauge visually displays the degree of contamination of the element.
The colored segments allow quick visual checking.

green	0 ... 2,5 bar / 0 ... 36.25 PSI	Element has service life left
yellow	2,5 ... 3,0 bar / 36.25 ... 43.5 PSI	Element is contaminated and should be changed
red	>3,0 bar / >43.5 PSI	Bypass valve open, unfiltered oil passing to tank

Electrical Clogging Switch

The switch is used where an electrical signal is needed to indicate when the element needs changing. The switch can turn on a light, or shut the machine down, or any further function controlled by an electric signal. The switching pressure is 2,5 bar / 36.25 PSI and this allows the element to be changed before the bypass setting of 3 bar / 43.5 PSI is reached.

Maximum Voltage	Switch Type
42 V (normally open)	G42NO
42 V (normally closed)	G42NC
110 V (two-way contact)	G110
230 V (two-way contact)	G230

Filter Bowl with Threaded Connection

Under some circumstances such as a tall reservoir or one with oil levels which vary greatly during operation, it is necessary to extend the filter bowl so that the returning oil returns beneath the surface and does not entrain air in the process. The optional bowl with a female thread allows an extension to be fitted quite simply. The one piece design also allows for inline applications.

Leakage Oil Connection

Seal or case drain lines can be connected to the filter through either of the clogging indicator ports providing that the leakage oil can accept a pressure of 3 bar / 43.5 PSI. It ensures that no unfiltered oil can return to the reservoir.

Filter Bowl with Threaded Connection and Diffuser

Diffusers mounted to the filter bowl minimise foaming and reduce noise of high return line flows. For further details on STAUFF Diffusers please refer to the "Hydraulic Accessories" section on page E36.

Attention: Connection pipe not included in scope of delivery!

Size SRV	for Return Line Filter Size	Dimensions (mm/in)			
		øD	L	Thread G	Hex
SRV-114-B16	RF 014/030	60	139	G1	46
SRV-114-N16		2.36	5.47	1 NPT	1.81
SRV-200-B20	RF 045/070	82	139	G1-1/4	60
SRV-200-N20		3.23	5.47	1-1/4 NPT	2.36
SRV-227-B24	RF 090/130	82	200	G1-1/2	60
SRV-227-N24		3.23	7.87	1-1/2 NPT	2.36

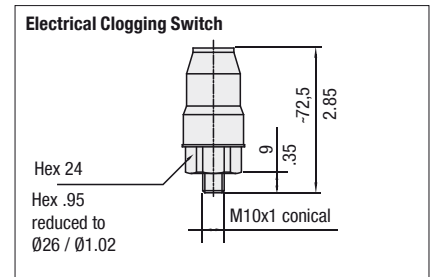
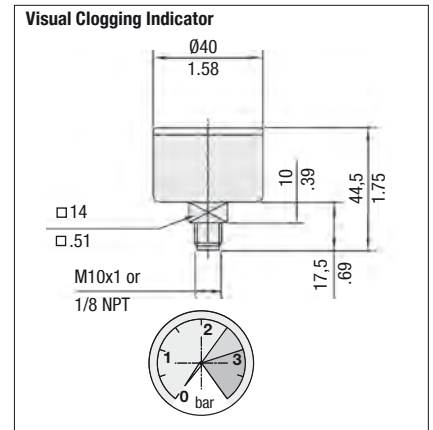

Dimensions in mm/in

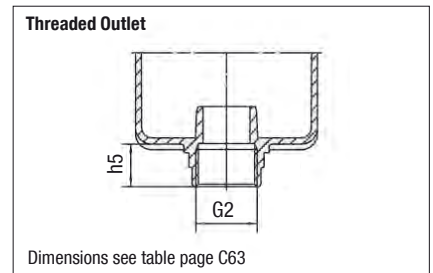

Dimensions see table page C63

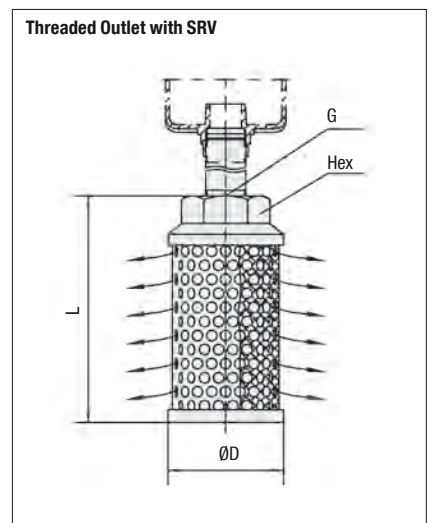
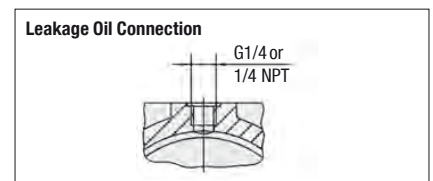

Return Line Filters ■ Type RF Flow Characteristics

The following characteristics are valid for mineral oils with a density of 0,85 kg/dm³ and the kinematic viscosity of 30 mm²/s (30cSt). The characteristics have been determined in accordance to ISO 3968. Multipass filter ratings have been obtained in accordance to ISO 16889. The housing pressure drop is directly proportional to the oil density. Consult STAUFF for details.

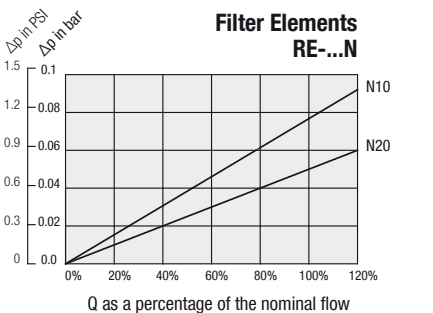
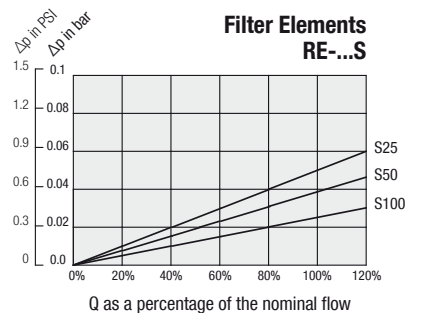
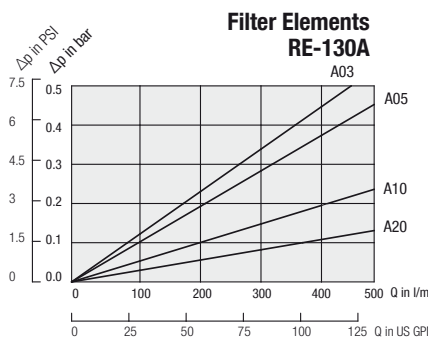
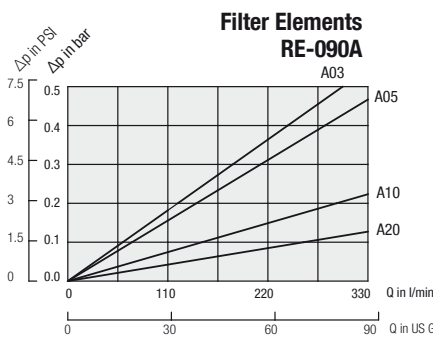
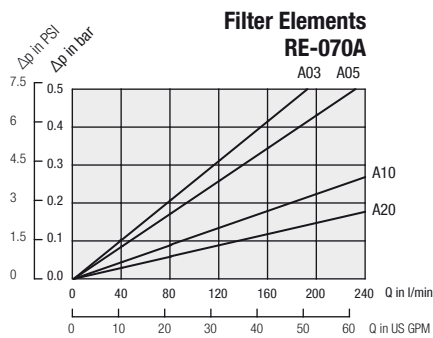
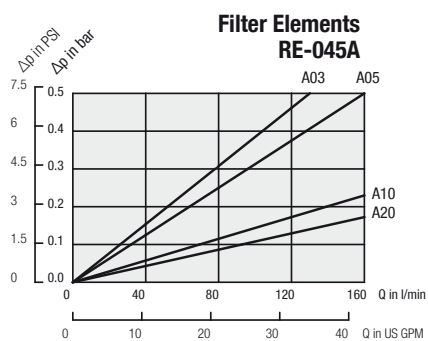
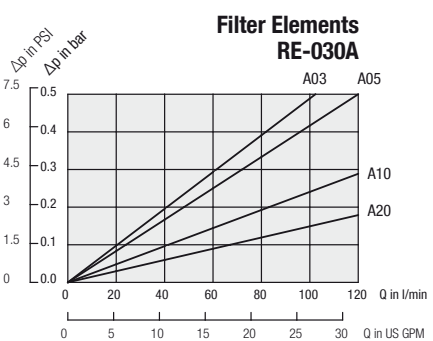
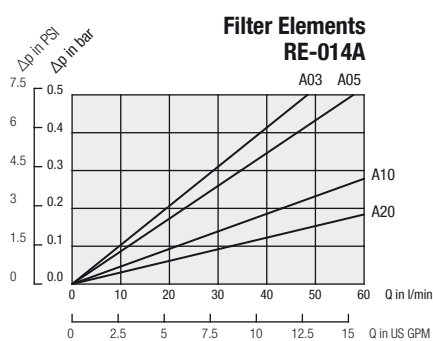
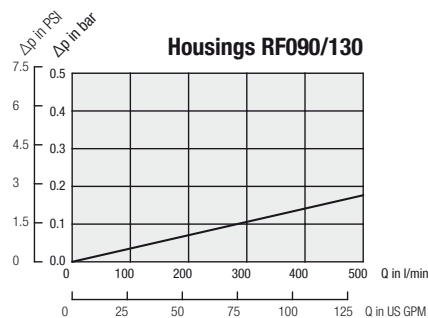
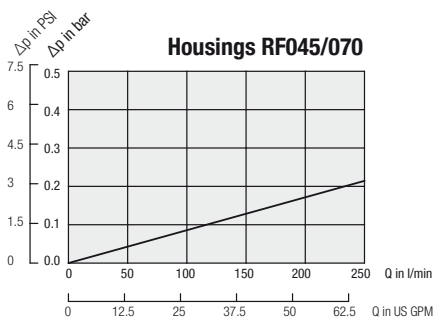
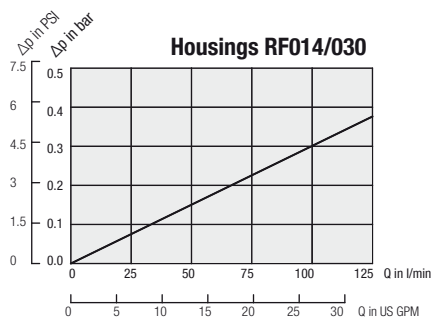

Return Line Filters ■ Type RF Flow Characteristics

The following characteristics are valid for mineral oils with a density of 0,85 kg/dm³ and the kinematic viscosity of 30 mm²/s (30cSt). The characteristics have been determined in accordance to ISO 3968. Multipass filter ratings have been obtained in accordance to ISO 16889. The housing pressure drop is directly proportional to the oil density. Consult STAUFF for details.

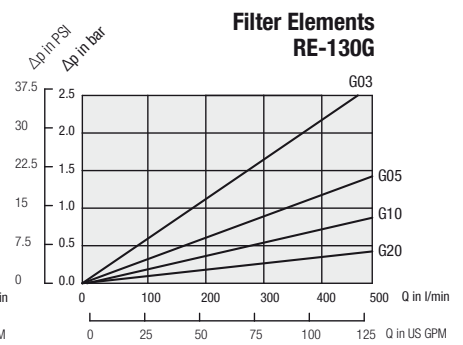
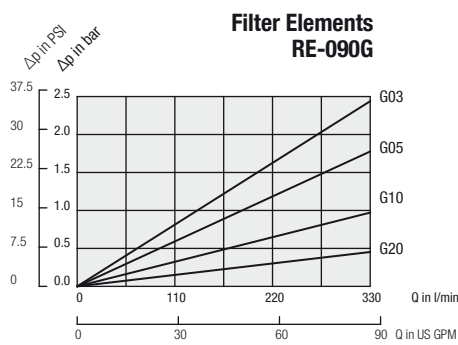
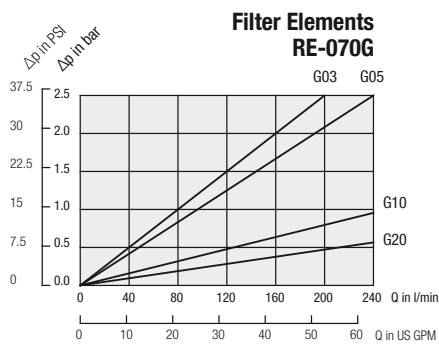
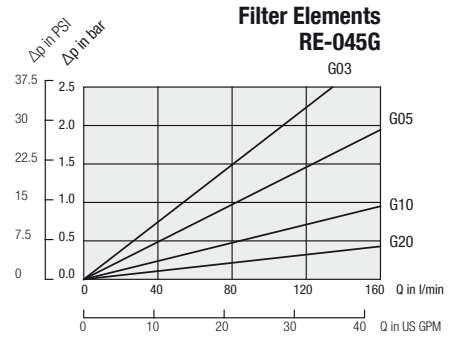
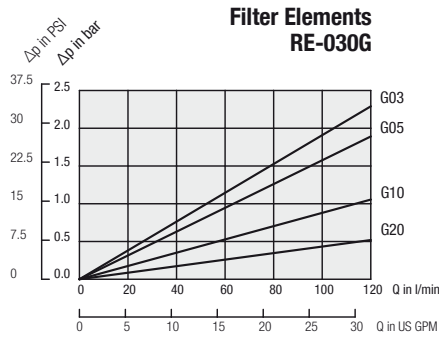
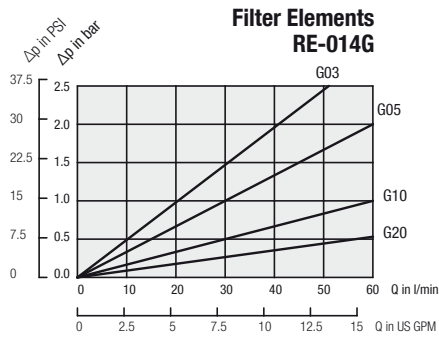

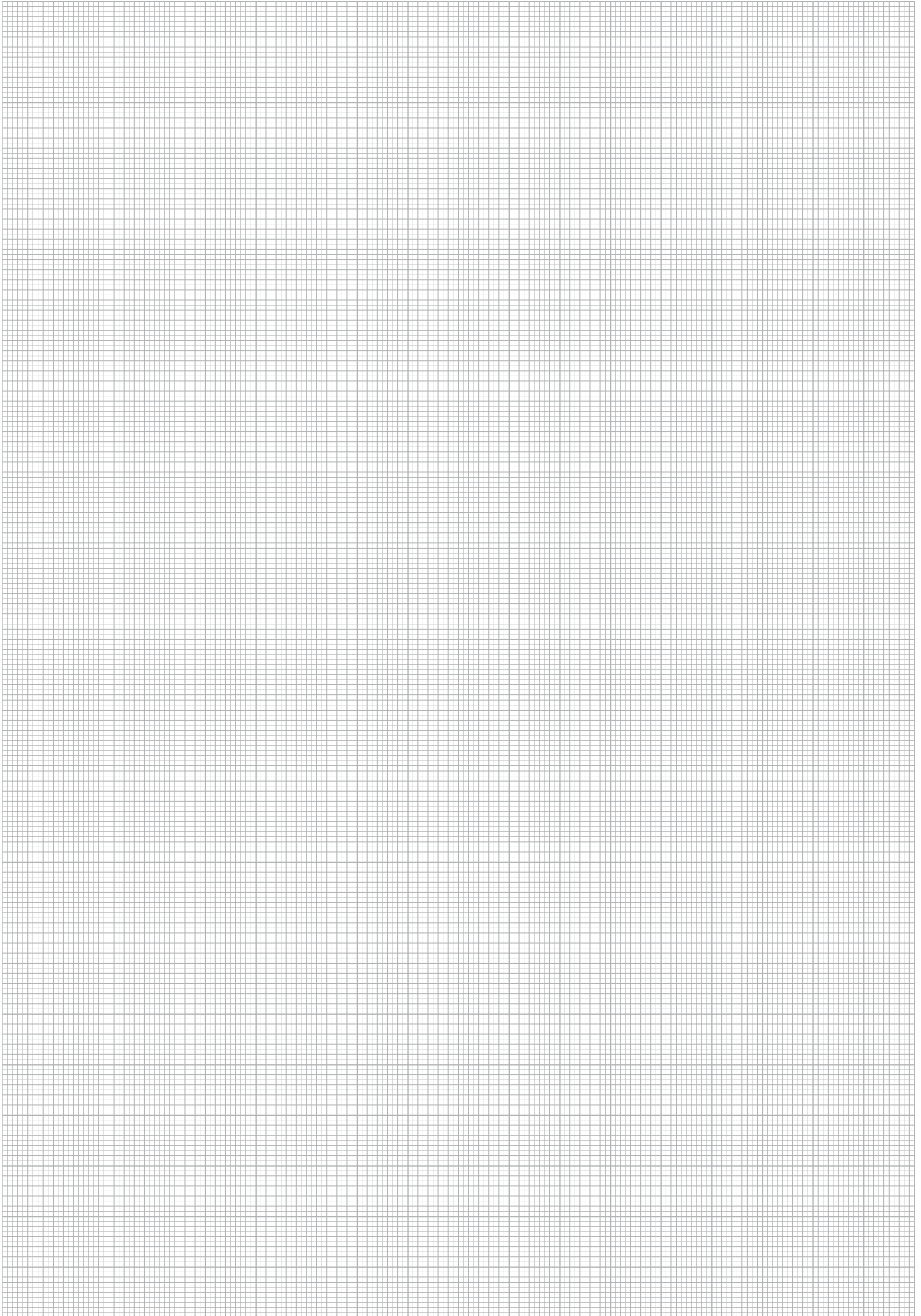

Return Line Filters ▪ Type RFA

Product Description

STAUFF RFA Return Line Filters are a one piece design and can be used as a tank top or an in-line filter. They are mounted in the return line and if 100% of the system oil is filtered, provide the optimum removal of contaminant for the systems. This provides the pump with clean oil, thus reducing contaminant generated wear. A high efficiency of contaminant removal is assured by using STAUFF RE Replacement Filter Elements. The high dirt-hold capacity of STAUFF Elements ensures a long service life and as a result reduced maintenance costs.

Technical Data
Construction

- Tank Top or in-line mounting

Materials

- Filter housing: Aluminium
- Sealings: NBR (Buna-N®)
FPM (Viton®)
EPDM (Ethylene Propylene Diene Monomer Rubber)
Other sealing materials on request

Port Connection

- SAE O-ring thread

Operating Pressure

- Max. 25 bar / 365 PSI

Temperature Range

- -10°C ... +100°C / +14°F ... +212°F

Filter Elements

- Specifications see page C72

Media Compatibility

- Mineral oils, other fluids on request

Options and Accessories
Valve

- Bypass valve (integrated in the filter element) Opening pressure 3 bar ± 0,3 bar / 43.5 PSI ± 4.35 PSI
Other settings available on request

Clogging Indicators

- Visual clogging indicator 0 ... 4 bar / 0 ... 58 PSI coloured segments
- Electrical clogging switch, setting 2,5 bar / 36.25 PSI
Other clogging indicators available on request

Return Line Filters - Type RFA

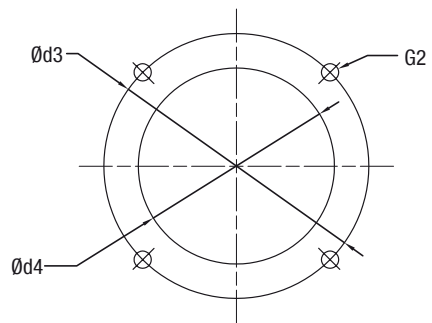
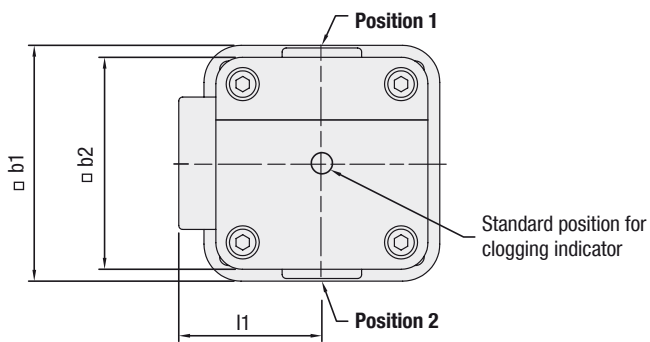
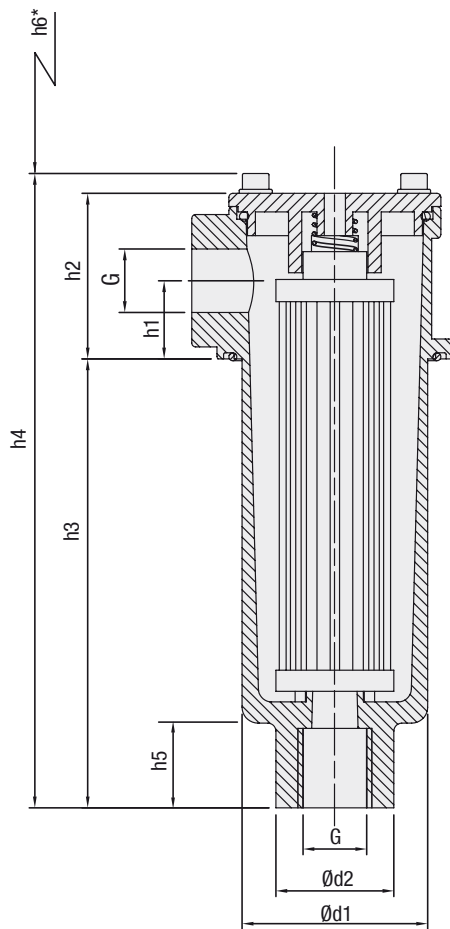

Mounting Detail

* recommended space for element change

Return Line Filters ▪ Type RFA

Thread Connection G	Filter Size RFA030
SAE O-ring Thread U	1-1/16-12
SAE O-ring Thread U1	3/4-16

Dimensions (mm/in)	Filter Size RFA030
h1	25,5
	1.16
h2	62,5
	2.46
h3	169,5
	6.67
h4	239,5
	9.43
h5	32
	1.26
h6	210
	8.27
b1	89
	3.50
b2	80
	3.15
d1	70
	2.76
d2	44,5
	1.75
d3	100
	3.94
d4	74
	2.91
l1	54
	2.16
G2	M6 or 1/4 UNC

Return Line Filter Housings / Complete Filters ▪ Type RFA

RFA **030** ... **B** / **U** / **M** / **G** / **L1** / **X**

1 2 3 4 5 6 7 8 9 10

1 Type

Return Line Filter **RFA**

2 Group

Flow **Size**
30 l/min / 110 US GPM **030**
Note: Exact flow will depend on filter element selected.
Consult technical data on pages C74.

3 Filter Material

Material	Max. Δp *collapse	Micron ratings available	Code
Without filter element	-	-	...
Inorg. glass fibre	25 bar / 363 PSI	3, 5, 10, 20	G
Stainless fibre	30 bar / 435 PSI		A
Filter paper	10 bar / 145 PSI	10, 20	N
Stainless mesh	30 bar / 435 PSI	25, 50, 100, 200	S

Note: *Collapse/burst resistance as per ISO 2941.
Other materials on request.

4 Micron Rating

3 μm	03
5 μm	05
10 μm	10
20 μm	20
25 μm	25
50 μm	50
100 μm	100
200 μm	200

Note: Other micron ratings on request.

5 Sealing Material

NBR (Buna®) **B**
FPM (Viton®) **V**
EPDM **E**
Note: Other sealing materials on request

6 Connection Style

Connection Style	Thread	Code
SAE-O-ring Thread	1-1/16-12	U
SAE-O-ring Thread	3/4-16	U1

7 Clogging Indicator

	Position*	Code
Without Clogging Indicator	-	0
Visual Clogging Indicator		M
Electrical Clogging Switch 42 V, NO	1 2	G42NO
Electrical Clogging Switch 42 V, NC		G42NC
Electrical Clogging Switch 110 V		G110
Electrical Clogging Switch 230 V		G230

Note: *Position of clogging indicator see page C70.
Without any code: assembly in the middle of the filter cover.

8 Outlet Style

Standard outlet (without thread) **0**
Filter bowl with threaded outlet **G**

9 Additional Features

	Position*	
Without leakage oil connection	-	none
Leakage oil connection	1 2	L

Note: *Position of the leakage oil connection see page C70.
Without any code: assembly in the middle of the filter cover.

10 Design Code

Only for information **X**

Filter Elements ▪ Type RE

RE - **030** **G** **10** **B** / **X**

1 2 3 4 5 6

1 Type

Filter Element Series **RE**

2 Group

According to filter housing

3 Filter Material

Material	Max. Δp *collapse	Micron ratings available	Code
Inorg. glass fibre	25 bar / 363 PSI	3, 5, 10, 20	G
Stainless fibre	30 bar / 435 PSI		A
Filter paper	10 bar / 145 PSI	10, 20	N
Stainless mesh	30 bar / 435 PSI	25, 50, 100, 200	B, S

Note: *Collapse/burst resistance as per ISO 2941.
Bold types identify preferred material.
Other materials on request.

4 Micron Rating

3 μm	03
5 μm	05
10 μm	10
20 μm	20
25 μm	25
50 μm	50
100 μm	100
200 μm	200

Note: Other micron ratings on request.

5 Sealing Material

NBR (Buna®) **B**
FPM (Viton®) **V**
EPDM **E**
Note: Other sealing materials on request.

6 Design Code

Only for information **X**

Return Line Filters ■ Type RFA

Visual Clogging Indicator

The gauge visually displays the degree of contamination of the element.
The colored segments allow quick visual checking.

green	0 ... 2,5 bar / 0 ... 36.25 PSI	Element has service life left
yellow	2,5 ... 3,0 bar / 36.25 ... 43.5 PSI	Element is contaminated and should be changed
red	>3,0 bar / >43.5 PSI	Bypass valve open, unfiltered oil passing to tank

Electrical Clogging Switch

The switch is used where an electrical signal is needed to indicate when the element needs changing. The switch can turn on a light, or shut the machine down, or any further function controlled by an electric signal. The switching pressure is 2,5 bar / 36.25 PSI and this allows the element to be changed before the bypass setting of 3 bar / 43.5 PSI is reached.

Maximum Voltage	Switch Type
42 V (normally open)	G42NO
42 V (normally closed)	G42NC
110 V (two-way contact)	G110
230 V (two-way contact)	G230

Filter Bowl with Threaded Connection

Under some circumstances such as a tall reservoir or one with oil levels which vary greatly during operation, it is necessary to extend the filter bowl so that the returning oil returns beneath the surface and does not entrain air in the process. The optional bowl with a female thread allows an extension to be fitted quite simply. The one piece design also allows for inline applications.

Leakage Oil Connection

Seal or case drain lines can be connected to the filter through either of the clogging indicator ports providing that the leakage oil can accept a pressure of 3 bar / 43.5 PSI. It ensures that no unfiltered oil can return to the reservoir.

Filter Bowl with Threaded Connection and Diffuser

Diffusers mounted to the filter bowl minimise foaming and reduce noise of high return line flows. For further details on STAUFF Diffusers please refer to the "Hydraulic Accessories" section on page E36.

Attention: Connection pipe not included in scope of delivery!

Size SRV	for Return Line Filter Size	Dimensions (mm/in)			
		øD	L	Thread G	Hex
SRV-114-B16	RFA030	60	139	G1	46
SRV-114-N16		2.36	5.47	1 NPT	1.81

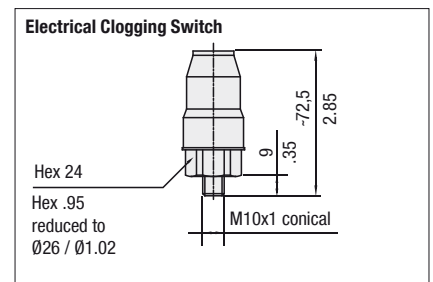
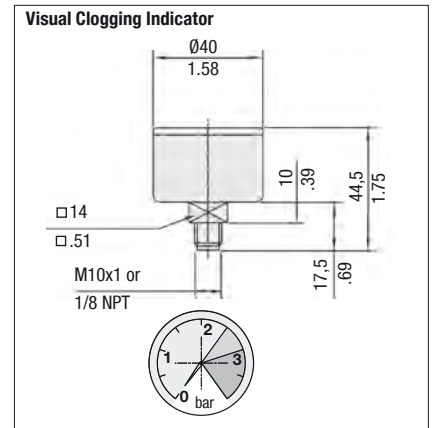

Dimensions in mm/in

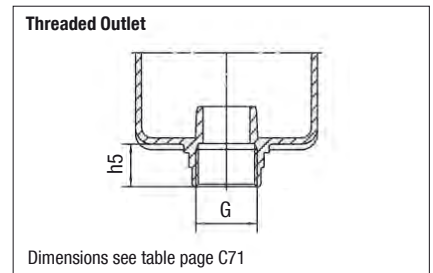

Dimensions see table page C71

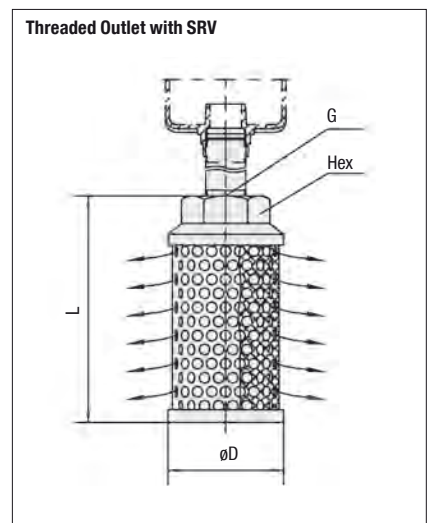
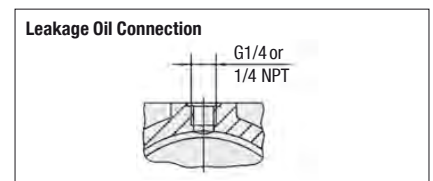

Return Line Filters - Type RFA Flow Characteristics

The following characteristics are valid for mineral oils with a density of 0,85 kg/dm³ and the kinematic viscosity of 30 mm²/s (30cSt). The characteristics have been determined in accordance to ISO 3968. Multipass filter ratings have been obtained in accordance to ISO 16889. The housing pressure drop is directly proportional to the oil density. Consult STAUFF for details.

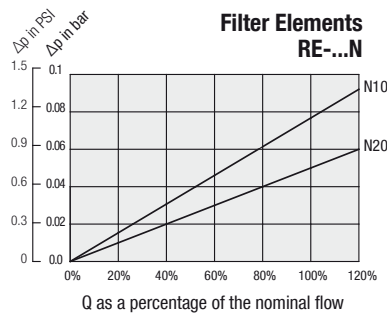
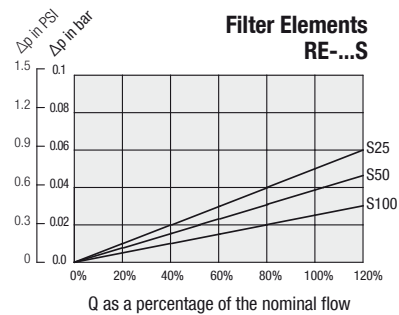
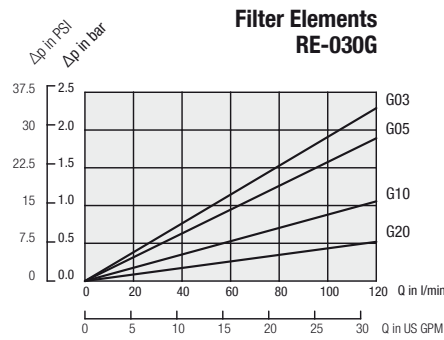
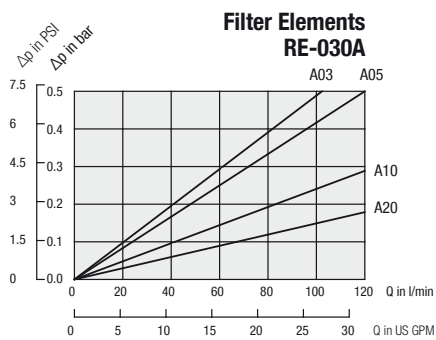
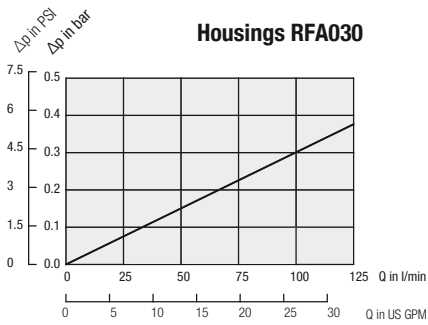

Return Line Filters ▪ Type RFB

Product Description

STAUFF RFB Return Line Filters are designed as tank top filters. They are mounted directly on the tank top and if 100% of the system oil is filtered they provide the optimum removal of contaminant from the system. This provides the pump with clean oil thus reducing contaminant generated wear. Because of its low weight and compact design, the STAUFF RFB Filters are ideally suited for mobile hydraulic applications. A high efficiency of contaminant removal is assured by using STAUFF RE Replacement Filter Elements. The high dirt-hold capacity of STAUFF Elements ensures a long service life and as a result reduced maintenance costs.

Technical Data
Construction

- Tank Top flange mounting

Materials

- Filter head: Aluminium
- Filter bowl & cap: Glass Fibre Reinforced Polyamide
- Sealings: NBR (Buna-N®)
FPM (Viton®)
EPDM (Ethylene Propylene Diene Monomer Rubber)
Other sealing materials on request

Port Connection

- BSP
- NPT
- SAE O-ring thread

Operating Pressure

- Max. 10 bar / 145 PSI

Temperature Range

- -10°C ... +100°C / +14°F ... +212°F

Filter Elements

- Specifications see page C78

Media Compatibility

- Mineral oils, other fluids on request

Options and Accessories
Valve

- Bypass valve (integrated in the filter element) Opening pressure 3 bar ± 0,3 bar / 43.5 PSI ± 4.35 PSI
Other settings available on request

Clogging Indicators

- Visual clogging indicator 0 ... 4 bar / 0 ... 58 PSI coloured segments
- Electrical clogging switch, setting 2,5 bar / 36.25 PSI
Other clogging indicators available on request

Return Line Filters - Type RFB

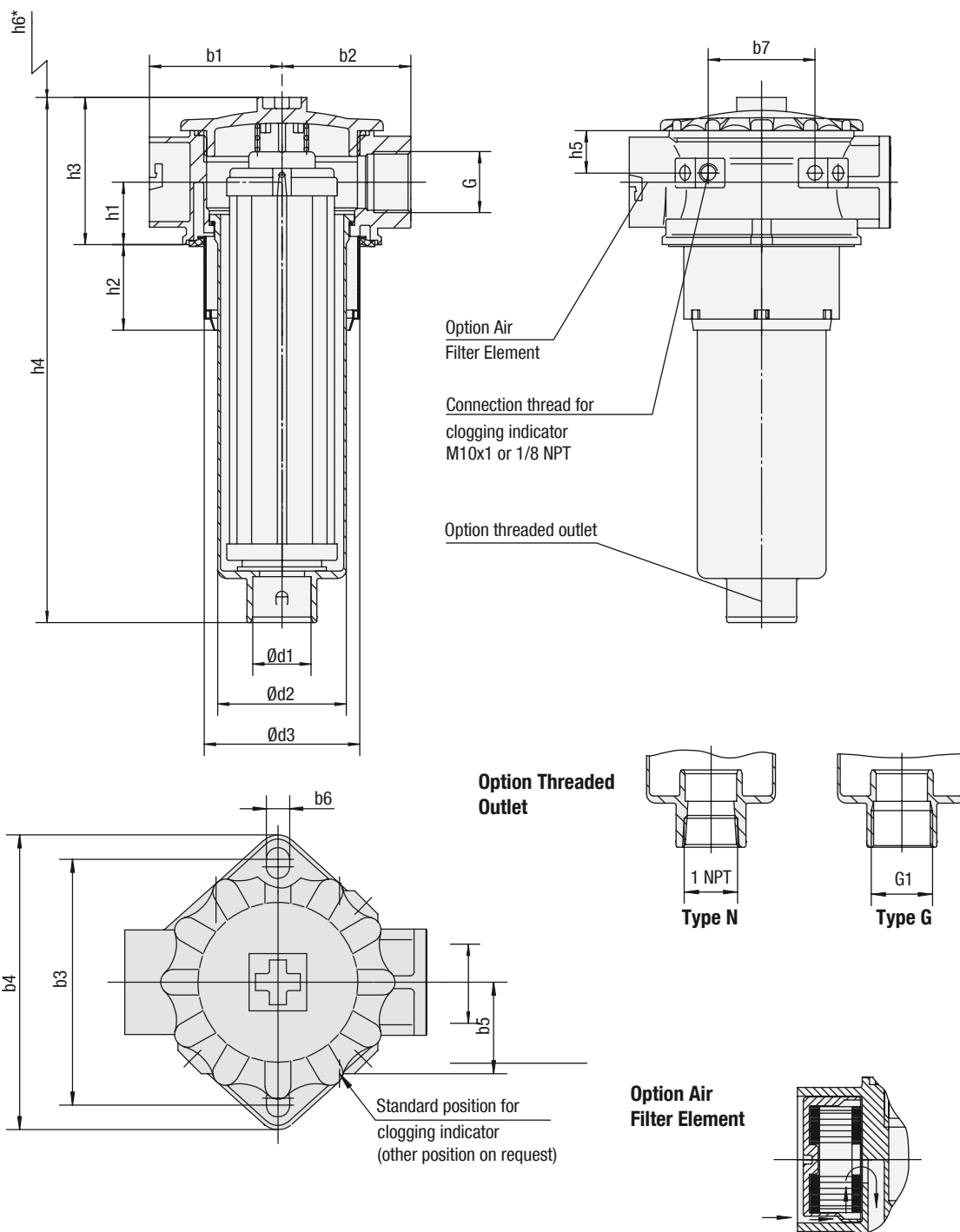

* recommended space for element change

Return Line Filters ■ Type RFB

Thread Connection G	Filter Size RFB					
	022		046		052	
BSP	3/4	1	3/4	1	3/4	1
NPT	3/4	1	3/4	1	3/4	1
SAE O-ring Thread	1-5/16-12					

Dimensions (mm/in)	Filter Size RFB					
	022		046		052	
h1	34		34		34	
	1.34		1.34		1.34	
h2	46,5		46,5		46,5	
	1.83		1.83		1.83	
h3	80		80		80	
	3.15		3.15		3.15	
h4	205,5		285,5		351,5	
	8.09		11.24		13.84	
h5	23		23		23	
	.91		.91		.91	
h6	154		239		305	
	6.26		9.41		12.01	
d1	32		32		32	
	1.26		1.26		1.26	
d2	70		70		70	
	2.76		2.76		2.76	
d3	84,5		84,5		84,5	
	3.33		3.33		3.33	
b1	72		72		72	
	2.84		2.84		2.84	
b2	70		70		70	
	2.76		2.76		2.76	
b3	115,5		115,5		115,5	
	4.55		4.55		4.55	
b4	138,5		138,5		138,5	
	5.45		5.45		5.45	
b5	43		43		43	
	1.69		1.69		1.69	
b6	11		11		11	
	.43		.43		.43	
b7	58		58		58	
	2.28		2.28		2.28	

Return Line Filter Housings / Complete Filters ■ Type RFB

RFB **022** ... **B** / **B** / **M** / **G** / **L10** / **X**

1 2 3 4 5 6 7 8 9 10

1 Type

Return Line Filter **RFB**

2 Group

Flow	Size
75 l/min / 22 US GPM	022
165 l/min / 46 US GPM	046
185 l/min / 52 US GPM	052

Note: Exact flow will depend on filter element selected.
Consult technical data on pages C80.

3 Filter Material

Material	Max. Δp^* collapse	Micron ratings available	Code
Without filter element	-	-	...
Inorg. glass fibre	25 bar / 363 PSI	3, 5, 10, 20	G
Stainless fibre	30 bar / 435 PSI	3, 5, 10, 20	A
Filter paper	10 bar / 145 PSI	10, 20	N
Stainless mesh	30 bar / 435 PSI	10, 25, 50, 100, 200	S

Note: *Collapse/burst resistance as per ISO 2941.
Other materials on request.

4 Micron Rating

3 μ m	03
5 μ m	05
10 μ m	10
20 μ m	20
25 μ m	25
50 μ m	50
100 μ m	100
200 μ m	200

Note: Other micron ratings on request.

5 Sealing Material

NBR (Buna®)	B
FPM (Viton®)	V
EPDM	E

Note: Other sealing materials on request.

6 Connection Style

Connection Style	Group			Code
	022	046	052	
BSP	1			B
BSP	3/4			B1
NPT	1			N
NPT	3/4			N1
SAE-O-ring Thread	1-5/16-12			U

Note: Bold types identify preferred connection style.

7 Clogging Indicator

	Position*	Code
Without Clogging Indicator	-	0
Visual Clogging Indicator		M
Electrical Clogging Switch 42 V, NO	1 2	G42NO
Electrical Clogging Switch 42 V, NC	1 2	G42NC
Electrical Clogging Switch 110 V	1 2	G110
Electrical Clogging Switch 230 V	1 2	G230

Note: *Position of clogging indicator see page C76.

Without any code: assembly in the middle of the filter cover.

8 Outlet Style

Standard outlet (without thread)	0
With thread G1	G
With thread 1 NPT	N

9 Air Filter Element

Without Air Filter Element	0
Filter paper 10 micron	L10

Note: Other materials and micron ratings on request.

10 Design Code

Only for information	X
----------------------	----------

Filter Elements ■ Type RE

RE - **022** **G** **10** **B** / **X**

1 2 3 4 5 6

1 Type

Filter Element Series **RE**

2 Group

According to filter housing

3 Filter Material

Material	Max. Δp^* collapse	Micron ratings available	Code
Inorg. glass fibre	25 bar / 363 PSI	3, 5, 10, 20	G
Stainless fibre	30 bar / 435 PSI	3, 5, 10, 20	A
Filter paper	10 bar / 145 PSI	10, 20	N
Stainless mesh	30 bar / 435 PSI	25, 50, 100, 200	S

Note: *Collapse/burst resistance as per ISO 2941.
Other materials on request.

4 Micron Rating

3 μ m	03
5 μ m	05
10 μ m	10
20 μ m	20
25 μ m	25
50 μ m	50
100 μ m	100
200 μ m	200

Note: Other micron ratings on request.

5 Sealing Material

NBR (Buna®)	B
FPM (Viton®)	V
EPDM	E

Note: Other sealing materials on request.

6 Design Code

Only for information	X
----------------------	----------

Air Filter Elements

REA - **046** **L** **10** **B** / **X**

1 2 3 4 5 6

1 Type

Air Filter Element **REA**

2 Group

Air filter for RFB 022/046/052 **046**

3 Filter Material

Filter Paper **L**

Note: Other materials on request.

4 Micron Rating

10 μ m **10**

Note: Other micron ratings on request.

5 Design Code

Only for information **X**

Return Line Filters ■ Type RFB

Visual Clogging Indicator

The gauge visually displays the degree of contamination of the element.
The colored segments allow quick visual checking.

green	0 ... 2,5 bar / 0 ... 36.25 PSI	Element has service life left
yellow	2,5 ... 3,0 bar / 36.25 ... 43.5 PSI	Element is contaminated and should be changed
red	>3,0 bar / >43.5 PSI	Bypass valve open, unfiltered oil passing to tank

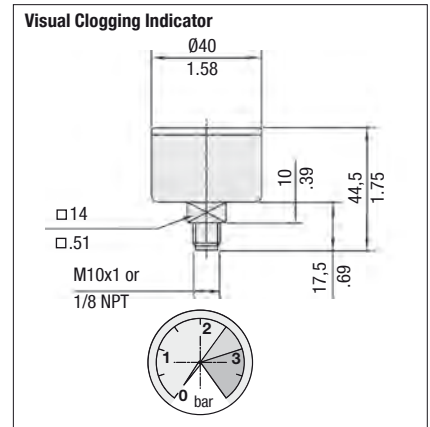
Electrical Clogging Switch

The switch is used where an electrical signal is needed to indicate when the element needs changing. The switch can turn on a light, or shut the machine down, or any further function controlled by an electric signal. The switching pressure is 2,5 bar / 36.25 PSI and this allows the element to be changed before the bypass setting of 3 bar / 43.5 PSI is reached.

Maximum Voltage	Switch Type
42 V (normally open)	G42NO
42 V (normally closed)	G42NC
110 V (two-way contact)	G110
230 V (two-way contact)	G230

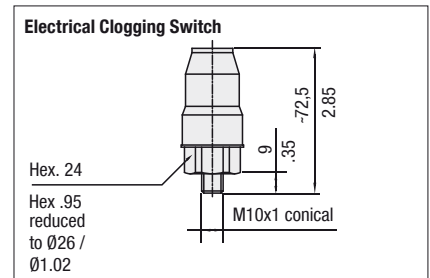

Dimensions in mm / in

Air Filter Element

Allows an effective filtration of the incoming air which avoids the infiltration of dirt particles into the hydraulic system. The standard air filter element is a 10 micron cellulose; other materials and micron ratings on request.

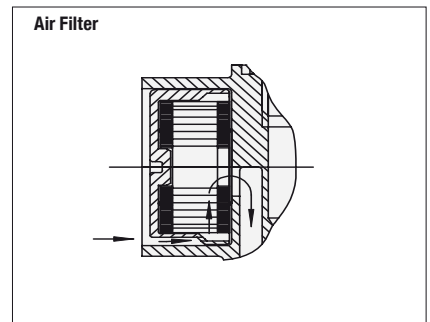
Filter Bowl with Threaded Connection

Under some circumstances such as a tall reservoir or one with oil levels which vary greatly during operation, it is necessary to extend the filter bowl so that the returning oil returns beneath the surface and does not entrain air in the process. The optional bowl with a female thread allows an extension to be fitted quite simply.

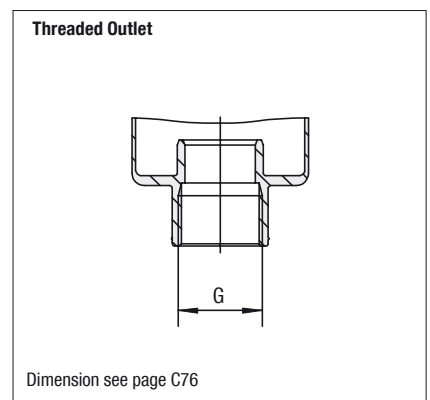

Dimension see page C76

Return Line Filters ■ Type RFB Flow Characteristics

The following characteristics are valid for mineral oils with a density of 0,85 kg/dm³ and the kinematic viscosity of 30 mm²/s (30cSt). The characteristics have been determined in accordance to ISO 3968. Multipass filter ratings have been obtained in accordance to ISO 16889. The housing pressure drop is directly proportional to the oil density. Consult STAUFF for details.

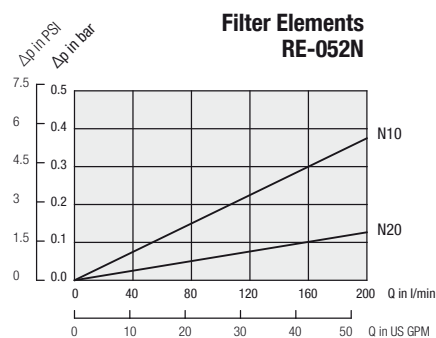
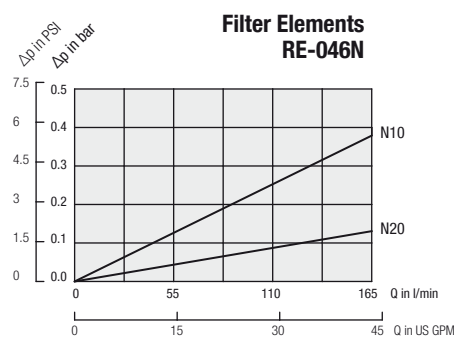
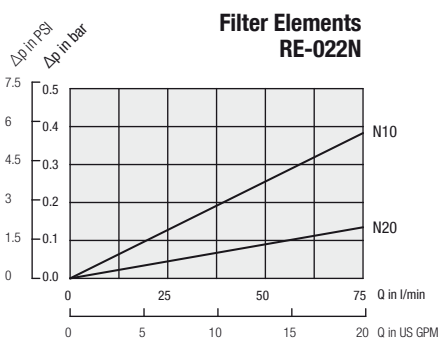
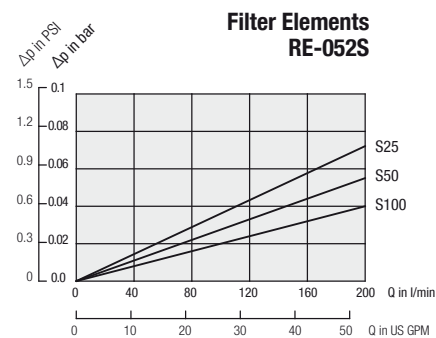
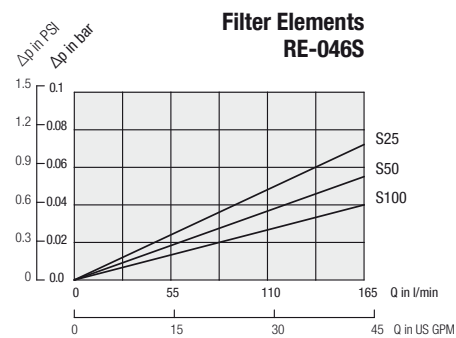
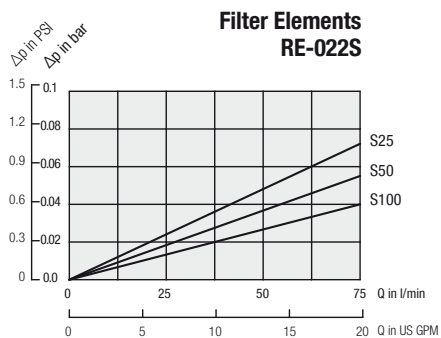
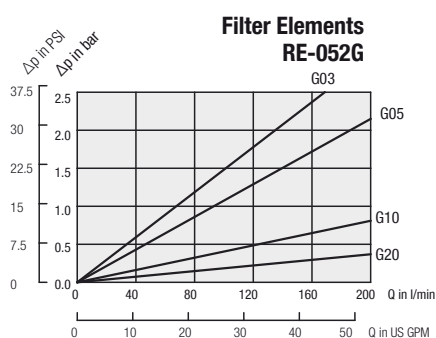
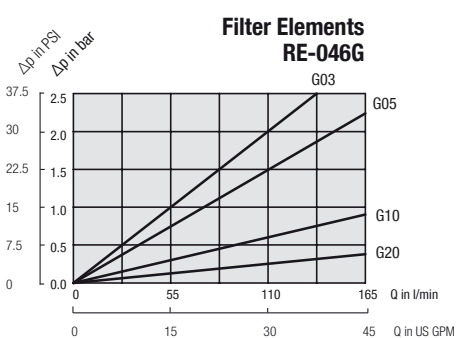
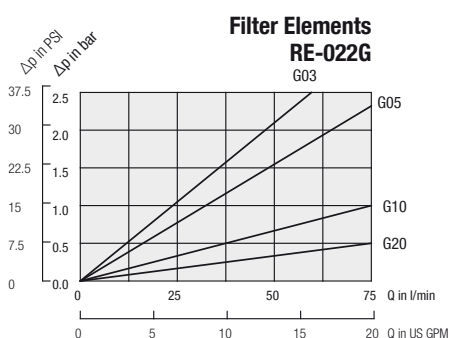
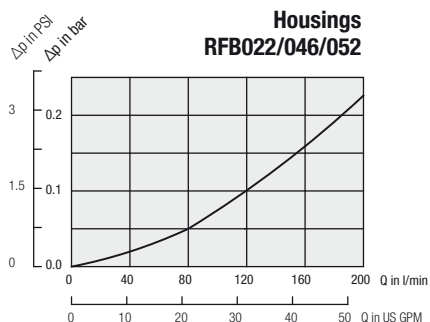

Return Line Filters ▪ Type RFS

Product Description

STAUFF RFS Carbon Steel Return Line Filters are designed as tank top or in-line filters. They are mounted directly on the tank top and if 100% of the system oil is filtered, they provide the optimum removal of contaminants from the system. This provides the pump with clean oil thus reducing contaminant generated wear. The filter bowl is designed with a connection, threaded or flanged, for extending the return oil beneath the surface thus preventing the entrainment of air. A high efficiency of contaminant removal is assured by using STAUFF RE Replacement Filter Elements. The high dirt-hold capacity of STAUFF Elements ensures a long service life and as a result reduced maintenance costs.

Technical Data
Construction

- Tank Top mounting or in-line mounting

Materials

- Filter Housing: Carbon Steel
- Sealings: NBR (Buna-N®)
FPM (Viton®)
EPDM (Ethylene Propylene Diene Monomer Rubber)
Other sealing materials on request

Port Connection

- BSP
- SAE flange 3000 PSI

Flow Rating

- Up to 1135 l/min / 300 US GPM

Operating Pressure

- Max. 25 bar / 365 PSI

Proof Pressure

- Min. 37,5 bar / 545 PSI

Temperature Range

- -10°C ... +100°C / +14°F ... +212°F

Filter Elements

- Specifications see page C84

Media Compatibility

- Mineral oils, other fluids on request

Options and Accessories
Valves

- Bypass valve (integrated in the filter element) Opening pressure 3 bar ± 0,3 bar / 43.5 PSI ± 4.35 PSI
Other settings available on request

Clogging Indicators

- Visual clogging indicator 0...4 bar / 0...58 PSI coloured segments
- Electrical clogging switch, setting 2,5 bar / 36.25 PSI
Other clogging indicators available on request

Return Line Filters - Type RFS

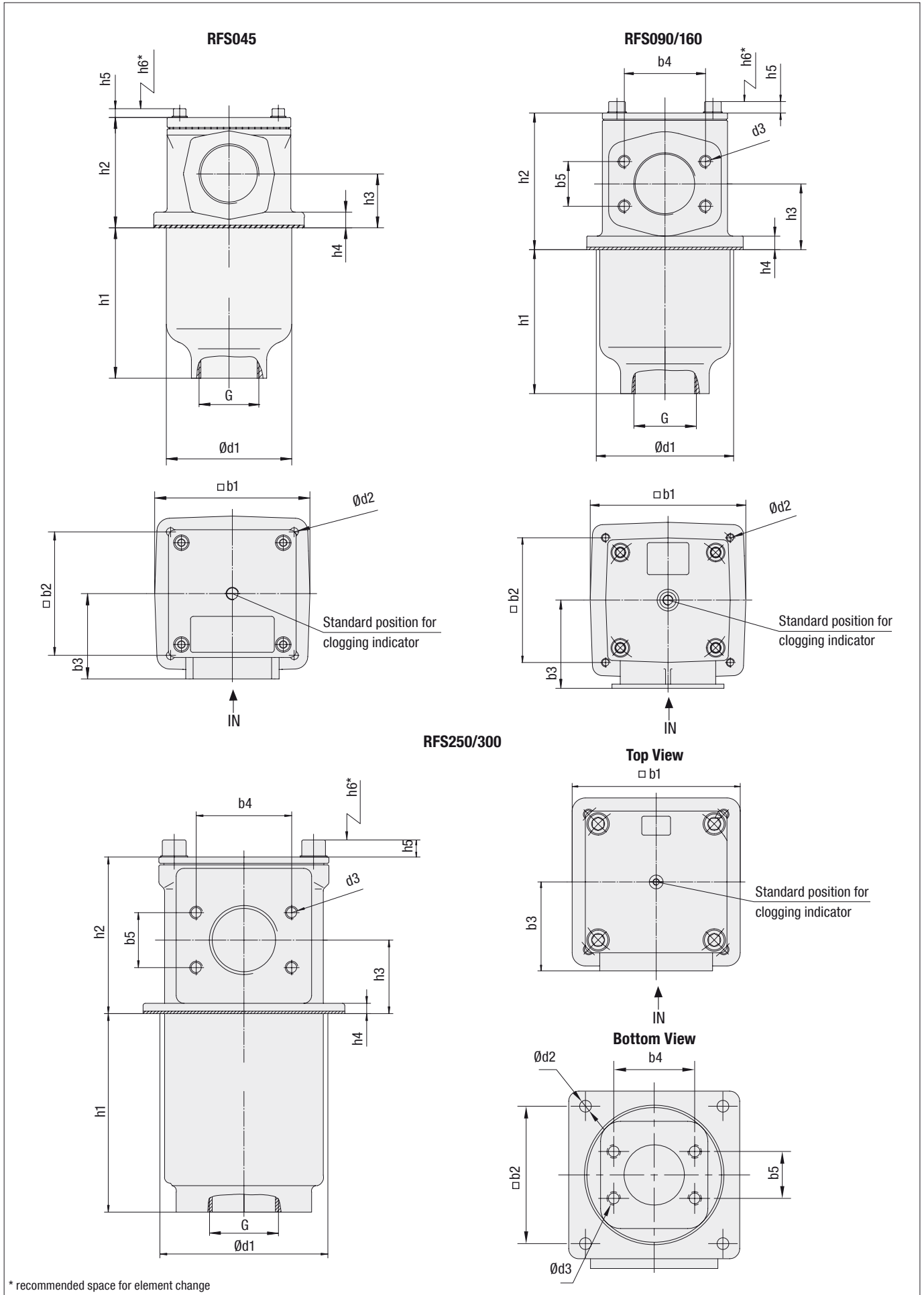

* recommended space for element change

Return Line Filters ▪ Type RFS

Thread Connection		Filter Size RFS				
		045	090	160	250	300
Inlet	BSP	1-1/2	2	-	-	-
	SAE Flange	-	2	3	3-1/2	4
Outlet G	BSP	1-1/2	2	3	-	-
	SAE Flange	-	-	-	3-1/2	4

Dimensions (mm/in)	Filter Size RFS				
	045	090	160	250	300
b1	120	150	196	255	255
	4.72	5.91	7.72	10.04	10.04
b2	95,5	120	155,5	205	205
	3.76	4.72	6.12	8.07	8.07
b3	66	85	110	135	145
	2.60	3.35	4.33	5.32	5.71
b4	-	77,8	106,4	120,7	130,2
	-	3.06	4.19	4.75	5.13
b5	-	42,9	61,9	69,5	77,8
	-	1.69	2.44	2.74	3.06
d1	100	135	180	208	208
	3.94	5.32	7.09	8.19	8.19
d2	6,5	9	13,5	17,5	17,5
	.26	.35	.53	.69	.69
d3	-	M12	M16	M16	M16
	-	1/2-UNC	5/8-UNC	5/8 UNC	5/8 UNC
h1	120	138	243	251	332
	4.72	5.43	9.57	9.88	13.07
h2	88	131	167	198	241
	3.47	5.16	6.57	7.80	9.49
h3	43	63	84	93	121
	1.69	2.48	3.31	3.66	4.76
h4	13	13	13	13	13
	.51	.51	.51	.51	.51
h5	7	12	12	12	12
	.28	.47	.47	.47	.47
h6	130	180	320	350	460
	5.11	7.09	12.60	13.78	18.11

Return Line Filter Housings / Complete Filters ▪ Type RFS

RFS **250** ... **B** / **F** / **M** / **F** / **X**

1 2 3 4 5 6 7 8 9

1 Type

Carbon Steel Return Line Filter **RFS**

2 Group

Flow	Size
170 l/min / 45 US GPM	045
340 l/min / 90 US GPM	090
600 l/min / 160 US GPM	160
945 l/min / 250 US GPM	250
1135 l/min / 300 US GPM	300

Note: Exact flow will depend on filter element selected.
Consult technical data on pages C86 / C87.

3 Filter Material

Material	Max. Δp^* collapse	Micron ratings available	Code
Without filter element	-	-	...
Inorg. glass fibre	25 bar / 363 PSI	3, 5, 10, 20	G
Stainless fibre	30 bar / 435 PSI		A
Filter paper	10 bar / 145 PSI	10, 20	N
Stainless mesh	30 bar / 435 PSI	25, 50, 100, 200	S

Note: *Collapse/burst resistance as per ISO 2941.
Other materials on request.

4 Micron Rating

3 μ m	03
5 μ m	05
10 μ m	10
20 μ m	20
25 μ m	25
50 μ m	50
100 μ m	100
200 μ m	200

Note: Other micron ratings on request.

5 Sealing Material

NBR (Buna®)	B
FPM (Viton®)	V
EPDM	E

Note: Other sealing materials on request.

6 Connection Style

Connection Style	Group					Code
	045	090	160	250	300	
BSP	1-1/2	2	-	-	-	G
SAE Flange 3000 PSI	-	2	3	3-1/2	4	F

7 Clogging Indicator

	Position*		Code
Without Clogging Indicator	-		0
Visual Clogging Indicator	1	2	M
Electrical Clogging Switch 42 V, NO			G42NO
Electrical Clogging Switch 42 V, NC			G42NC
Electrical Clogging Switch 110 V			G110
Electrical Clogging Switch 230 V			G230

Note: *Position of clogging indicator see page C82.

Without any code: assembly in the middle of the filter cover.

8 Outlet Style

Connection Style	Group					Code
	045	090	160	250	300	
BSP	1-1/2	2	3	-	-	G
SAE Flange 3000 PSI	-	-	-	3-1/2	4	F

9 Design Code

Only for information **X**

Filter Elements ▪ Type RE

RE - **250** **G** **10** **B** / **X**

1 2 3 4 5 6

1 Type

Filter Element Series **RE**

2 Group

According to filter housing

3 Filter Material

Material	Max. Δp^* collapse	Micron ratings available	Code
Inorg. glass fibre	25 bar / 363 PSI	3, 5, 10, 20	G
Stainless fibre	30 bar / 435 PSI		A
Filter paper	10 bar / 145 PSI	10, 20	N
Stainless mesh	30 bar / 435 PSI	25, 50, 100, 200	S

Note: *Collapse/burst resistance as per ISO 2941.
Other materials on request.

4 Micron Rating

3 μ m	03
5 μ m	05
10 μ m	10
20 μ m	20
25 μ m	25
50 μ m	50
100 μ m	100
200 μ m	200

Note: Other micron ratings on request.

5 Sealing Material

NBR (Buna®)	B
FPM (Viton®)	V
EPDM	E

Note: Other sealing materials on request.

6 Design Code

Only for information **X**

Return Line Filters ■ Type RFS

Visual Clogging Indicator

The gauge visually displays the degree of contamination of the element.
The colored segments allow quick visual checking.

green	0 ... 2,5 bar / 0 ... 36.25 PSI	Element has service life left
yellow	2,5 ... 3,0 bar / 36.25 ... 43.5 PSI	Element is contaminated and should be changed
red	>3,0 bar / >43.5 PSI	Bypass valve open, unfiltered oil passing to tank

Electrical Clogging Switch

The switch is used where an electrical signal is needed to indicate when the element needs changing. The switch can turn on a light, or shut the machine down, or any further function controlled by an electric signal. The switching pressure is 2,5 bar / 36.25 PSI and this allows the element to be changed before the bypass setting of 3 bar / 43.5 PSI is reached.

Maximum Voltage	Switch Type
42 V (normally open)	G42NO
42 V (normally closed)	G42NC
110 V (two-way contact)	G110
230 V (two-way contact)	G230

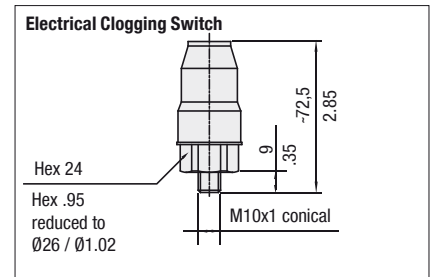
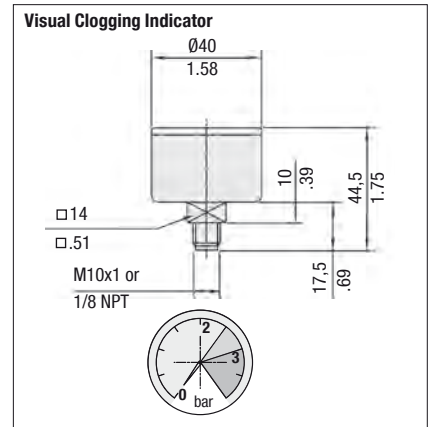

Dimensions in mm / in

Replacement Filter Elements RE Series
Product Description

STAUFF RE Replacement Filter Elements are manufactured in the common filter materials such as Stainless Fibre, Stainless Mesh, Cellulose and Inorganic Glass Fibre. As standard all Replacement Elements RE have tin plated steel parts for use with aggressive media such as water glycol, upon request you also can get other materials. All Replacement Elements made by STAUFF comply with quality specifications in accordance with international standards.

Order Code

RE - 250 G 10 B / X

1 2 3 4 5 6

1 Type

 Filter Element Series **RE**
2 Group

 According to filter housing
Note: See order code page C84.

3 Filter Material

Material	Max. Δp*collapse	Micron ratings available	Code
Inorg. glass fibre	25 bar / 363 PSI	3, 5, 10, 20	G
Stainless fibre	30 bar / 435 PSI		A
Filter paper	10 bar / 145 PSI	10, 20	N
Stainless mesh	30 bar / 435 PSI	25, 50, 100, 200	S

Note: *Collapse/burst resistance as per ISO 2941.
Other materials on request.

4 Micron Rating

3 µm	03
5 µm	05
10 µm	10
20 µm	20
25 µm	25
50 µm	50
100 µm	100
200 µm	200

Note: Other micron ratings on request.

5 Sealing Material

NBR (Buna®)	B
FPM (Viton®)	V
EPDM	E

Note: Other sealing materials on request.

6 Design Code

 Only for information **X**

Return Line Filters - Type RFS Flow Characteristics

The following characteristics are valid for mineral oils with a density of 0,85 kg/dm³ and the kinematic viscosity of 30 mm²/s (30cSt). The characteristics have been determined in accordance to ISO 3968. Multipass filter ratings have been obtained in accordance to ISO 16889. The housing pressure drop is directly proportional to the oil density. Consult STAUFF for details.

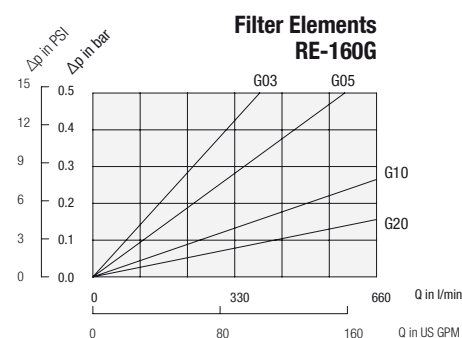
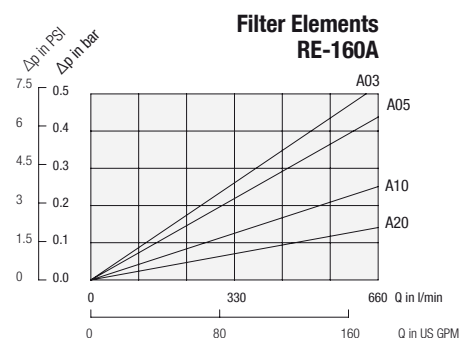
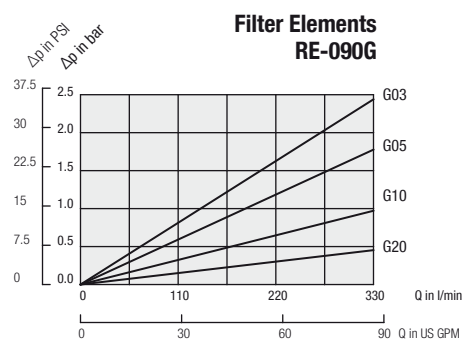
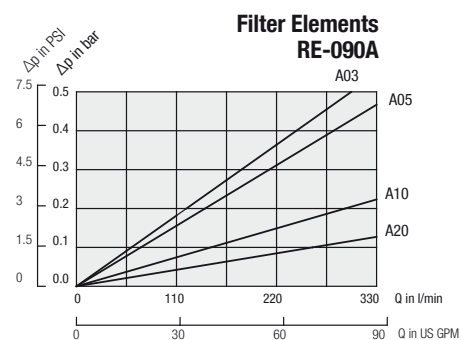
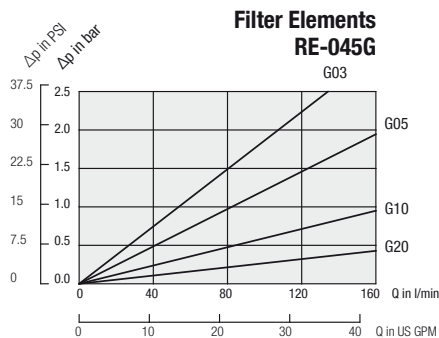
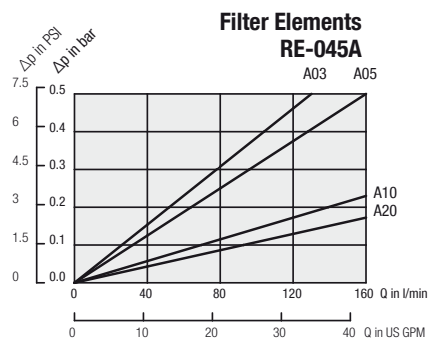
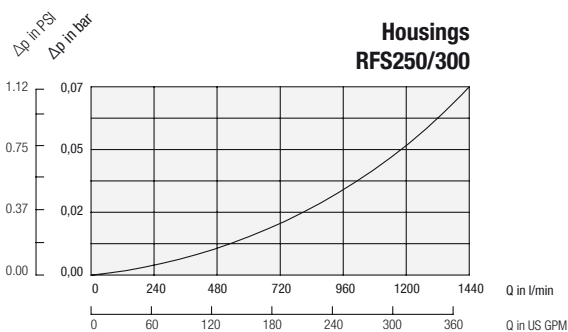
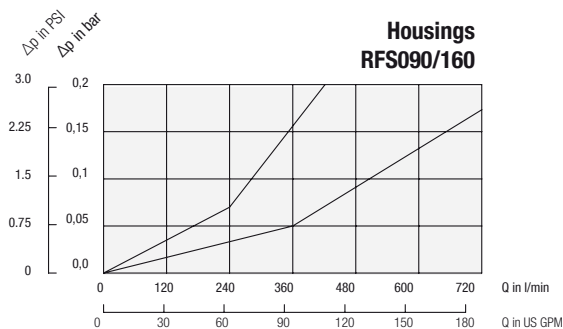
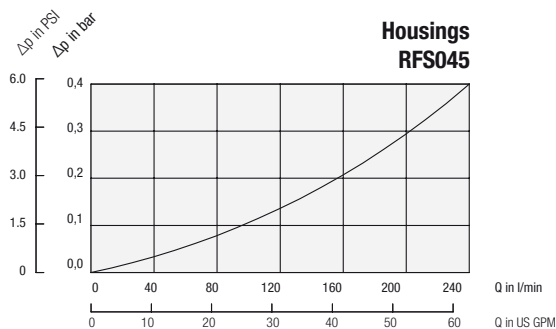

Return Line Filters ■ Type RFS Flow Characteristics

The following characteristics are valid for mineral oils with a density of 0,85 kg/dm³ and the kinematic viscosity of 30 mm²/s (30cSt). The characteristics have been determined in accordance to ISO 3968. Multipass filter ratings have been obtained in accordance to ISO 16889. The housing pressure drop is directly proportional to the oil density. Consult STAUFF for details.

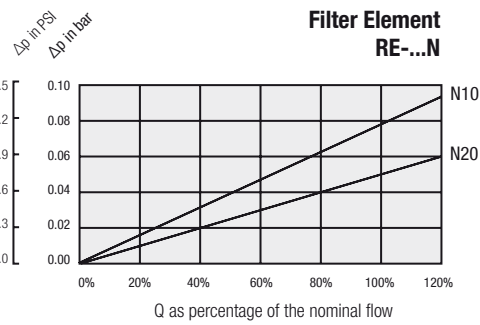
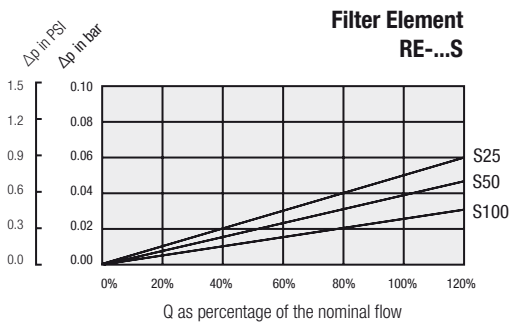
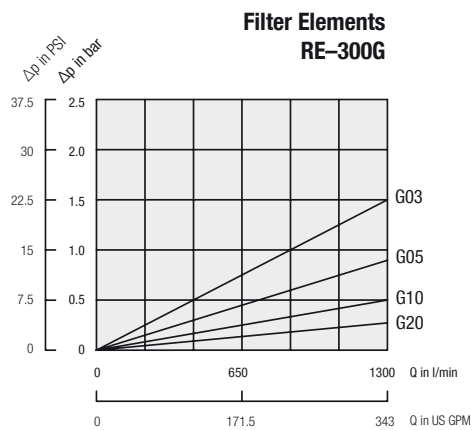
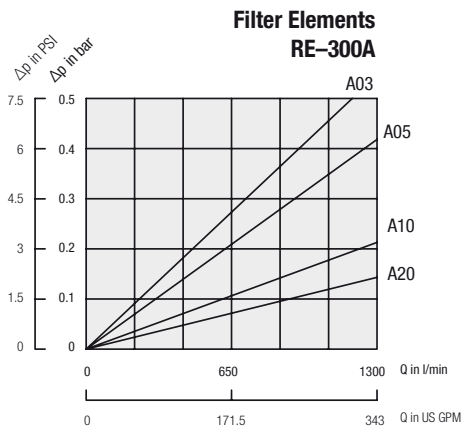
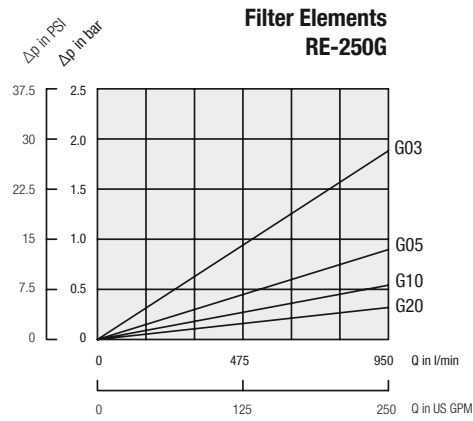
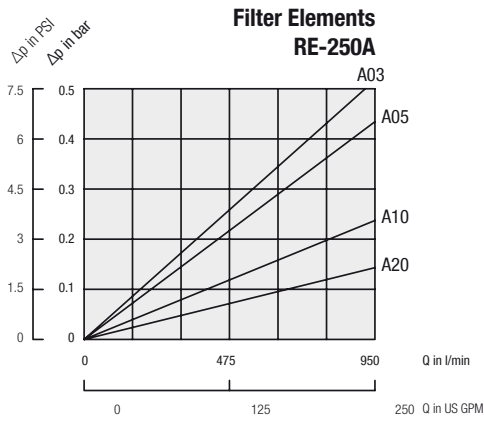

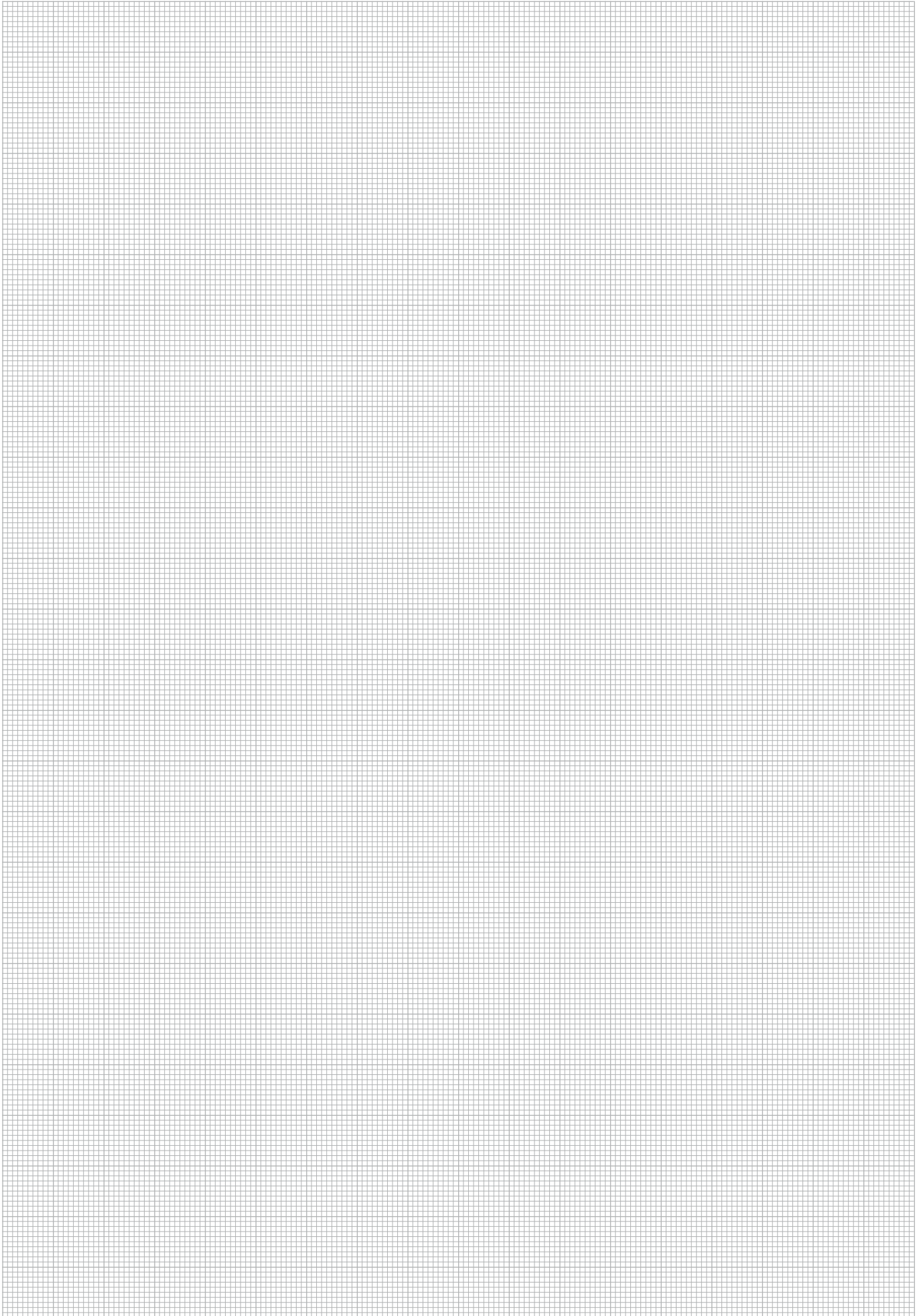

Return Line Filters ▪ Type RIF300

Product Description

STAUFF RIF300 Return Line Filters are designed for in-line hydraulic applications with a maximum working pressure of 34,5 bar / 500 PSI. Used together with STAUFF Filter Elements, a high efficiency of contaminant removal is assured.

Technical Data
Construction

- In-line assembly

Materials

- Filter head: Aluminium
- Filter bowl: Steel
- Filter cover: Cast Iron
- Sealings: NBR (Buna-N®)
FPM (Viton®)
Other sealing materials on request

Port Connection

- SAE Code 61 flange

Flow Rating

- Up to 1135 l/min / 300 US GPM

Operating Pressure

- Max. 34,5 bar / 500 PSI

Burst Pressure

- Min. 103 bar / 1500 PSI

Temperature Range

- -10°C ... +100°C / +14°F ... +212°F

Filter Elements

- Specifications see page C91

Media Compatibility

- Mineral oils, other fluids on request

Options and Accessories
Valve

- Bypass valve (integrated in the filter element)
 - Opening pressure 3,4 ^{+0,35} bar / 50 ⁺⁵ PSI
 - Allows unfiltered oil to bypass the contaminated element once the opening pressure has been reached
 - Other settings available on request

Clogging Indicators

- Visual clogging indicator 2,4 bar / 35 PSI
- Visual-electrical clogging indicator 2,4 bar / 35 PSI
- Other clogging indicators available on request

Return Line Filters ■ Type RIF300

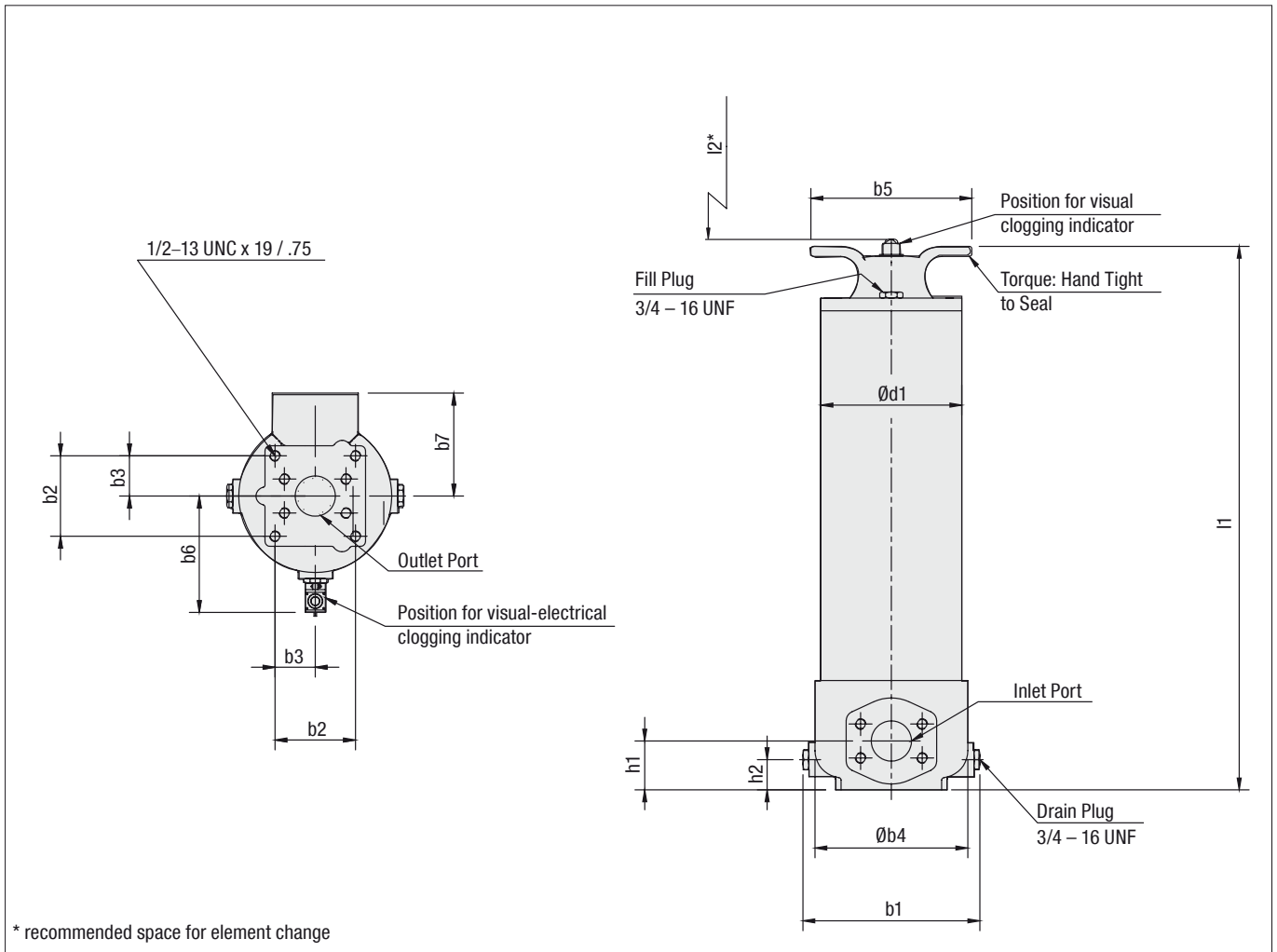

Dimensions in mm / in

Dimensions (mm/in)	Filter Size RIF 300
b1	220,4 8.68
b2	101,6 4
b3	50,8 2
b4	193 7.60
b5	186,44 7.34
b6	153,1 6.03
b7	127 5
d1	184,1 7.25
h1	61,7 2.43
h2	38,1 1.50
l1	1204 47.40
l2	991 39
Weight (kg/lbs)	39,2 86.2

Return Line Filter Housings / Complete Filters ■ Type RIF300

RIF
300
...
...
B /
 F /
 B /
 V /
 X

1
2
3
4
5
6
7
8
9

1 Type

 Return Line Filter RIF
2 Group

 With Standard Element 300
 With Deep Pleat Element 310
3 Filter Material

Material	Max. Δp*collapse	Micron ratings available	Code
Without filter element	-	-	...
Inorg. glass fibre (only RIF300)	30 bar / 435 PSI	3, 5, 10, 20	E
Inorg. glass fibre (only RIF310)	6,9 bar / 100 PSI	1, 3, 5, 10	E
Water removal (only RIF300)	6,9 bar / 100 PSI	10	EW

 Note: *Collapse/burst resistance as per ISO 2941.
 Other materials on request.

4 Micron Rating

1 μm	01
3 μm	03
5 μm	05
10 μm	10
20 μm	20

Note: Other micron ratings on request.

5 Sealing Material

 NBR (Buna®) B
 FPM (Viton®) V

Note: Other sealing materials on request.

6 Connection Style

Connection Style	Thread	Code
SAE Code 61 Flange	2-1/2	F

7 Valve

 Without Valve 0
 With Bypass Valve 3,4 bar / 50 PSI B
8 Clogging Indicator

 No Clogging Indicator none
 Visual Clogging Indicator V
 Visual-electrical Clogging Indicator P
9 Design Code

 Only for Information X

Filter Elements ■ Type SP

SP -
 300
E
10
B /
 X

1
2
3
4
5
6

1 Type

 Filter Element Series SP
2 Group

According to filter housing

3 Filter Material

Material	Max. Δp*collapse	Micron ratings available	Code
Without filter element	-	-	...
Inorg. glass fibre (only RIF300)	30 bar / 435 PSI	3, 5, 10, 20	E
Inorg. glass fibre (only RIF310)	6,9 bar / 100 PSI	1, 3, 5, 10	E
Water removal (only RIF300)	6,9 bar / 100 PSI	10	EW

 Note: *Collapse/burst resistance as per ISO 2941.
 Other materials on request.

4 Micron Rating

1 μm	01
3 μm	03
5 μm	05
10 μm	10
20 μm	20

Note: Other micron ratings on request.

5 Sealing Material

 NBR (Buna®) B
 FPM (Viton®) V

Note: Other sealing materials on request.

6 Design Code

 Only for information X

Return Line Filters - Type RIF300

Visual Clogging Indicator

Part number HIR-V is a clogging indicator actuated by the differential pressure across the filter element. The actuating pressure of 2,4 bar / 35 PSI allows the dirty element to be changed before the bypass setting of 3,4 bar / 50 PSI is reached.

Visual Clogging Indicator

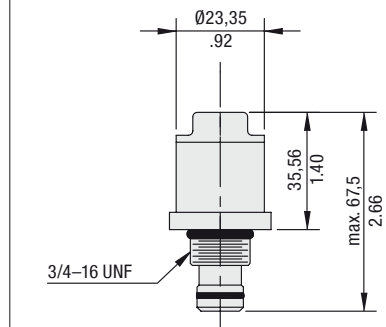

Visual/Electrical Clogging Indicator

Part number HIR-VE is used when an electrical signal is needed to indicate when the element needs changing. It is actuated by the differential pressure across the filter element. The actuating pressure of 2,4 bar / 35 PSI allows the dirty element to be changed before the bypass setting of 3,4 bar / 50 PSI is reached.

Visual/Electrical Clogging Indicator

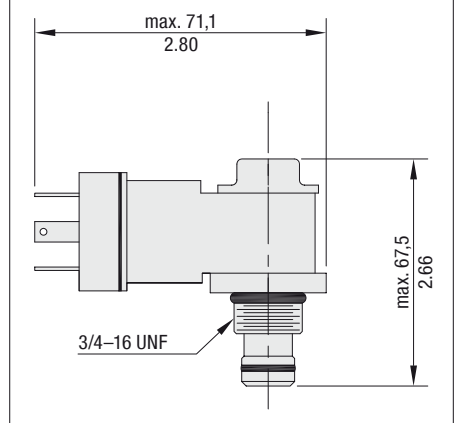

Dimensions in mm / in

HIR-VE Rated Capacity

4 A inductive
7 A 28 V DC resistive
7 A 250 V AC

Order Code

HIR	-	V
------------	----------	----------

1

2

1 Type

Clogging Indicator for RIF300 **HIR**

2 Visual / Electrical

Visual	V
Visual-electrical	VE

Wiring Diagram

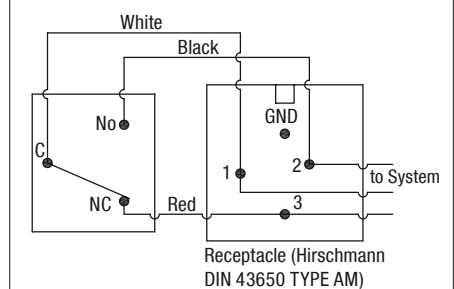

Note: The female plug (connector) is to be furnished by the customer.

Installation:

Lubricate both O-rings supplied with the indicator. Install in the cavity and torque to 41 ... 47 Nm / 30 ... 35 ft-lbs.

Return Line Filters ■ Type RIF300 Flow Characteristics

The following characteristics are valid for mineral oils with a density of 0,85 kg/dm³ and the kinematic viscosity of 30 mm²/s (30cSt). The characteristics have been determined in accordance to ISO 3968. Multipass filter ratings have been obtained in accordance to ISO 16889. The housing pressure drop is directly proportional to the oil density. Consult STAUFF for details.

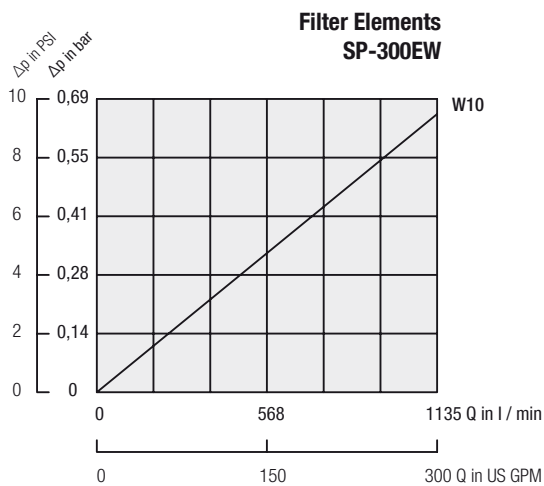
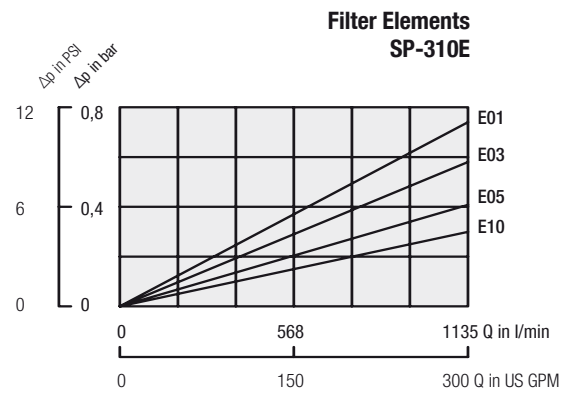
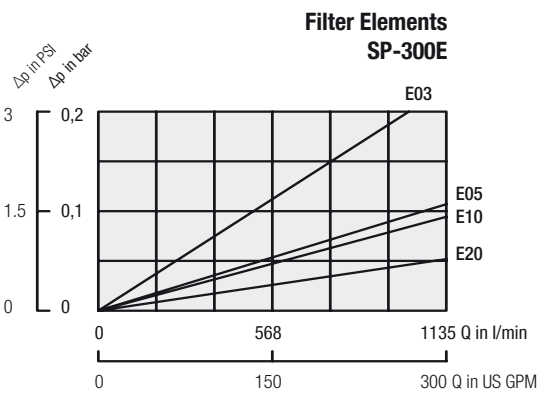
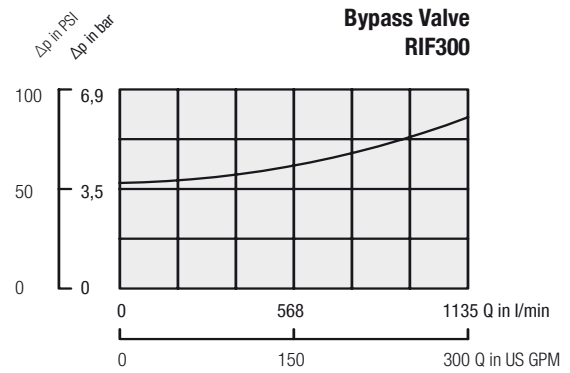
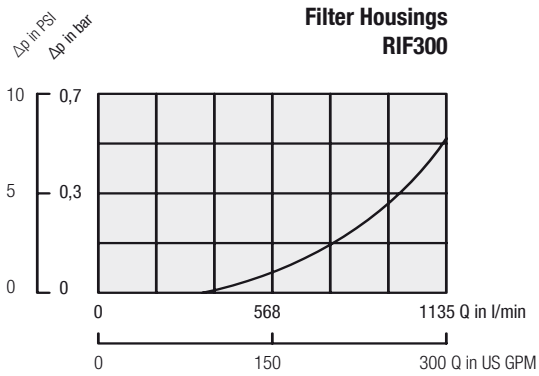

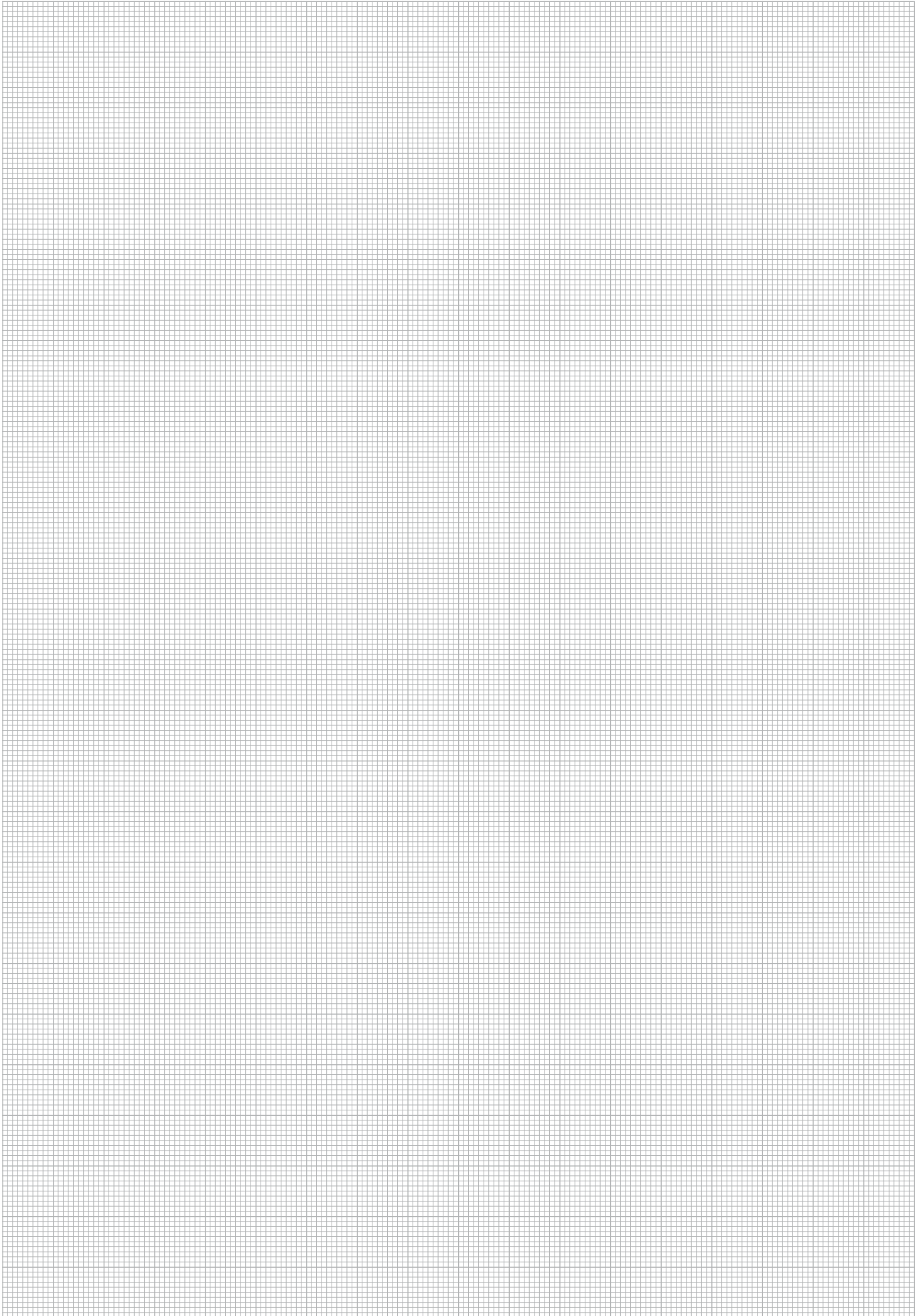

Return Line Filters ▪ Type RTF10/25

Product Description

STAUFF RTF10/25 Return Line Filters are designed as tank top filters with a maximum operating pressure of 3,4 bar / 49 PSI.

Technical Data
Construction

- Tank Top flange mounting

Materials

- Filter head: Aluminum
- Filter bowl: Polyamide
- Sealings: NBR (Buna-N®)
FPM (Viton®)
Other sealing materials on request

Port Connection

- BSP
- NPT
- SAE O-ring thread

Flow Rating

- Up to 95 l/min / 25 US GPM

Operating Pressure

- Max. 3,4 bar / 49 PSI

Burst Pressure

- Min. 10 bar / 145 PSI

Temperature Range

- -25°C ... +95°C / -13°F ... +203°F

Filter Elements

- Specifications see page C98

Media Compatibility

- Mineral oils, other fluids on request

Options and Accessories
Valve

- Bypass valve: Opening pressure 1,7 bar / 25 PSI
(integrated in the filter element) Other settings available on request

Clogging Indicators

- Visual clogging indicator, coloured segments
- Electrical clogging switch, adjustable
Other clogging indicators available on request

Return Line Filters ■ Type RTF10/25

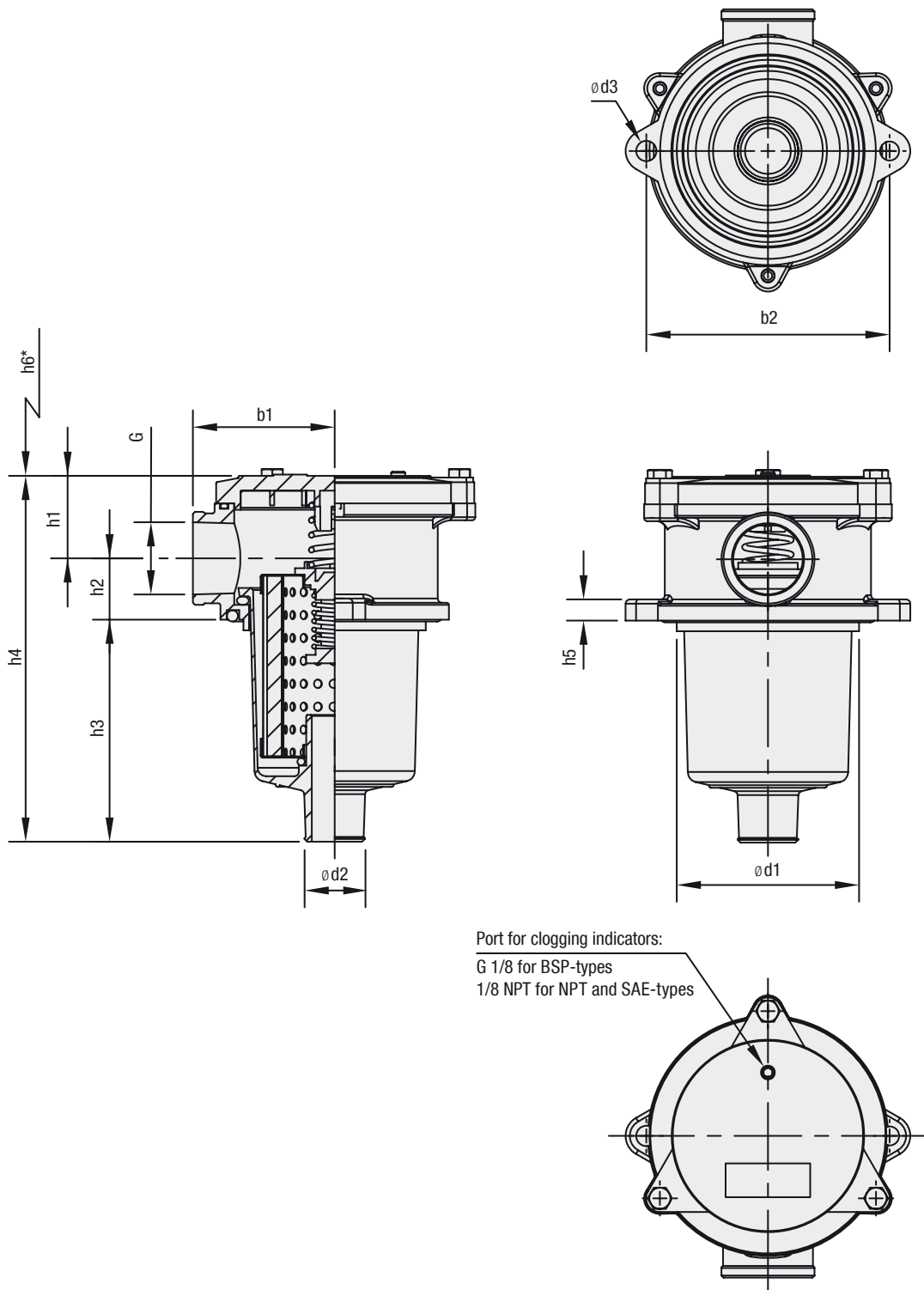

* recommended space for element change

Return Line Filters ▪ Type RTF10/25

Thread Connection G	Filter Size RTF		
	10S1	25S1	25S2
BSP	1/2	1	1
NPT	1/2	1	1
SAE O-ring	-	1-5/16-12	1-5/16-12

Dimensions (mm/in)	Filter Size RTF		
	10S1	25S1	25S2
h1	26	34	34
	1.02	1.34	1.34
h2	21	29	29
	.83	1.14	1.14
h3	88	103	151
	3.46	4.05	5.95
h4	136	166	212
	5.35	6.53	8.35
h5	8	10	10
	.32	.39	.39
h6	110	130	175
	4.33	5.12	6.89
b1	50	67	67
	1.97	2.64	2.64
b2	90	115	115
	3.54	4.52	4.52
d1	66	86	86
	2.60	3.39	3.39
d2	24	28	28
	.94	1.10	1.10
d3	7	9	9
	.28	.35	.35
Weight (kg/lbs)	0,45	0,9	1
	1	2	2.2

Return Line Filter Housings / Complete Filters ■ Type RTF10/25

RTF 25 ... B / N / S2 / V / X

1 2 3 4 5 6 7 8 9

1 Type

Return Line Filter **RTF**

2 Group

Flow	Size
38 l/min / 10 US GPM	10
90 l/min / 25 US GPM	25

Note: Exact flow will depend on filter element selected.
Consult technical data on pages C115

3 Filter Material

Material	Max. Δp^* collapse	Micron ratings available	Code
Without filter element	-	-	...
Inorg. glass fibre	3 bar / 43.5 PSI	3, 6, 10, 25	G
Filter paper	3 bar / 43.5 PSI	10, 25	D

*Note: Collapse/burst resistance as per ISO 2941
Other materials on request

4 Micron Rating

3 μm	03
6 μm	06
10 μm	10
20 μm	20
25 μm	25

Note: Other micron ratings on request

5 Sealing Material

NBR (Buna®) **B**
 FPM (Viton®) **V**
 Note: Other sealing materials on request

6 Connection Style

Connection Style	Group		Code
	10	25	
BSP	1/2	1	B
NPT	1/2	1	N
SAE O-ring Thread	-	1-5/16-12	S

7 Length

Bowl Length 1 **S1**
 Bowl Length 2 **S2**

Note: RTF 10 size available in bowl length 1 only.

8 Clogging Indicator

Without clogging indicator **none**
 Visual clogging indicator **V**
 Electrical clogging indicator **E**
 Note: See pages C96 and C117 for more details on indicator ports and types

9 Design Code

Only for information **X**

Filter Elements ■ Type RTE

RTE - 25 D 10 B / S2 / X

1 2 3 4 5 6 7

1 Type

Filter Element Series **RTE**

2 Group

According to filter housing

3 Filter Material

Material	Max. Δp^* collapse	Micron ratings available	Code
Inorg. glass fibre	3 bar / 43.5 PSI	3, 6, 10, 25	G
Filter paper	3 bar / 43.5 PSI	10, 25	D

*Note: Collapse/burst resistance as per ISO 2941
Other materials on request

4 Micron Rating

3 μm	03
6 μm	06
10 μm	10
20 μm	20
25 μm	25

Note: Other micron ratings on request

5 Sealing Material

NBR (Buna®) **B**
 FPM (Viton®) **V**
 Note: Other sealing materials on request

6 Length

Bowl Length 1 **S1**
 Bowl Length 2 **S2**

Note: RTF 10 size available in bowl length 1 only.

7 Design Code

Only for information **X**

Return Line Filters ■ Type RTF20

Product Description

STAUFF RTF20 Return Line Filters are designed as tank top filters with a maximum operating pressure of 10 bar / 145 PSI and flow rates up to 115 l/min / 30 US GPM. The filter bowl is designed to return the oil beneath the surface thus preventing entrainment of air. RTF20 series compact design and integral breather make them ideal for mobile hydraulic applications.

Technical Data
Construction

- Tank Top flange mounting

Materials

- Filter head: Aluminum
- Filter bowl & cap: Polyamide
- Sealings: NBR (Buna-N®)
FPM (Viton®)
Other sealing materials on request

Port Connection

- BSP
- NPT
- SAE O-ring thread

Flow Rating

- Up to 115 l/min / 30 US GPM

Operating Pressure

- Max. 10 bar / 145 PSI

Burst Pressure

- Min. 30 bar / 435 PSI

Temperature Range

- -25°C ...+95°C / -13°F ... +203°F

Integrated Breather

- Filter paper 10 µm
- Filter paper 40 µm

Filter Elements

- Specifications see page C102

Media Compatibility

- Mineral oils, other fluids on request

Options and Accessories
Valve

- Bypass valve: Opening pressure 1,7 bar / 25 PSI
(integrated in the filter element) Other settings available on request

Clogging Indicators

- Visual clogging indicator, coloured segments
- Electrical clogging switch, adjustable
Other clogging indicators available on request

Return Line Filters - Type RTF20

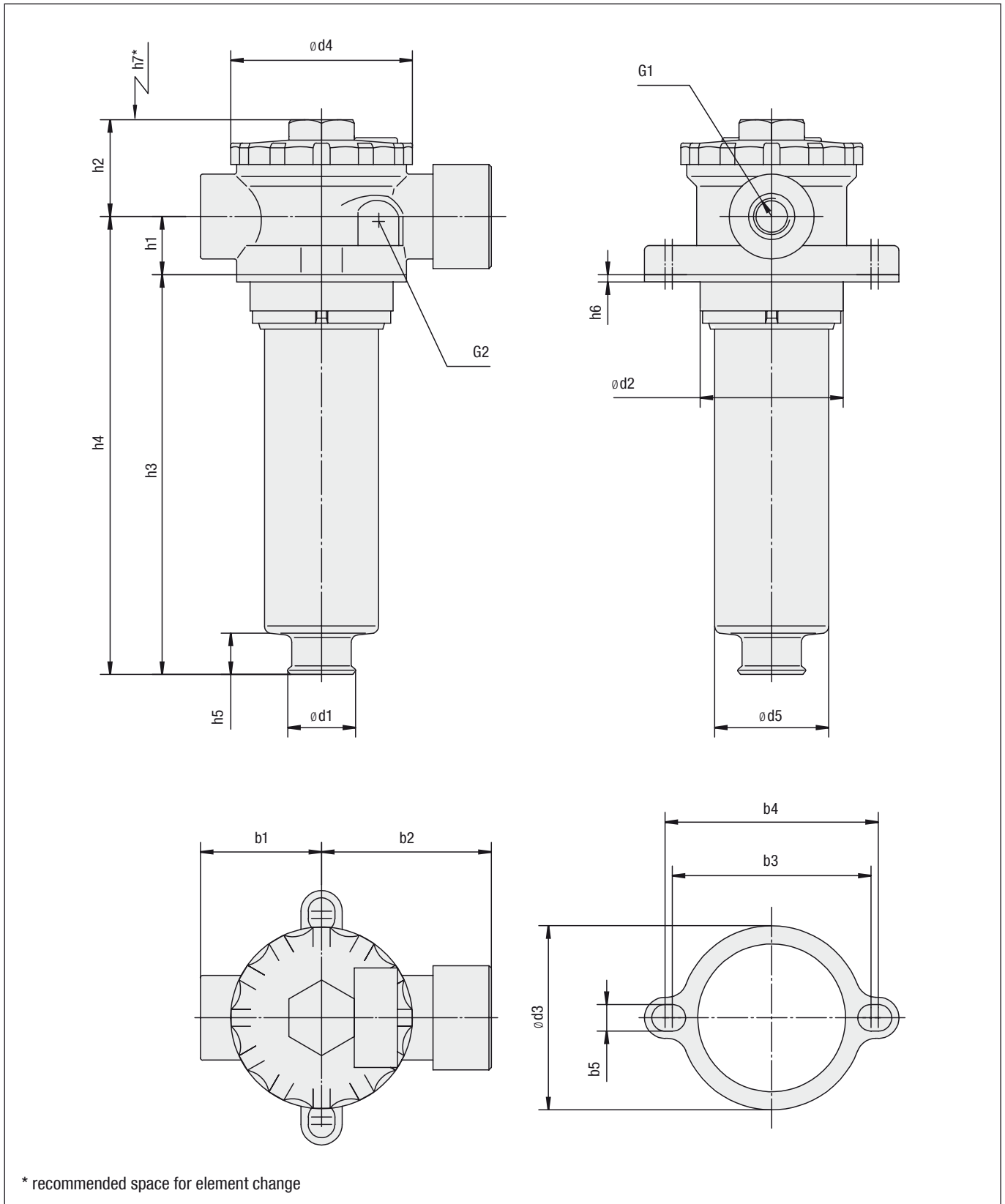

Return Line Filters ■ Type RTF20

Thread Connection G1	Filter Size RTF	
	020	
BSP	1/2	3/4
NPT	1/2	3/4
SAE Thread	3/4-16	1-1/16

Dimensions (mm/in)	Filter Size RTF	
	020	
b1	50	
	1.97	
b2	70	
	2.76	
b3	82	
	3.23	
b4	88	
	3.46	
b5	11	
	.43	
d1	28	
	1.10	
d2*	Min. 60 / Max. 63	
	Min. 2.36 / Max. 2.48	
d3	77	
	3.03	
d4	75	
	2.95	
d5	48	
	1.89	
h1	24	
	.94	
h2	37,5	
	1.48	
h3	178	
	7.01	
h4	202	
	7.95	
h5	16	
	.63	
h6	2	
	.07	
h7	210	
	8.27	
G2	G1/8 or	
	1/8 NPT	

* recommended diameter for mounting hole

Return Line Filter Housings / Complete Filters ▪ Type RTF20

RTF **20** **D** **10** **B** / **N1** / **V** / **B10** / **D** / **X**

1 2 3 4 5 6 7 8 9 10

1 Type

Return Line Filter **RTF20**

2 Group

Flow **Size**
115 l/min / 30 US GPM **20**
Note: Exact flow will depend on filter element selected.
Consult technical data on pages C115 / C116

3 Filter Material

Material	Max. Δp *collapse	Micron ratings available	Code
Without filter element	-	-	...
Inorg. glass fibre	25 bar / 363 PSI	6, 10, 20	G
Filter paper	10 bar / 145 PSI	10	D

*Note: Collapse/burst resistance as per ISO 2941
Other materials on request

4 Micron Rating

6 μ m **06**
10 μ m **10**
20 μ m **20**

Note: Other micron ratings on request

5 Sealing Material

NBR (Buna®) **B**
FPM (Viton®) **V**
Note: Other sealing materials on request

6 Connection Style

Connection Style	Thread	Code
BSP	1/2	B1
BSP	3/4	B2
NPT	1/2	N1
NPT	3/4	N2
SAE O-ring Thread	3/4-16	S1
SAE O-ring Thread	1-1/16-12	S2

7 Clogging Indicator

No clogging indicator **N**
Visual clogging indicator **V**
Electrical clogging indicator **E**
Note: See pages C100 and C117 for more details on indicator ports and types

8 Breather

10 μ m Filter Paper **B10**
40 μ m Filter Paper **B40**

9 Dipstick

Without dipstick **none**
With dipstick **D**

10 Design Code

Only for information **X**

Filter Elements ▪ Type RTE

RTE - **20** **D** **10** **B** / **X**

1 2 3 4 5 6

1 Type

Filter Element Series **RTE**

2 Group

According to filter housing

3 Filter Material

Material	Max. Δp *collapse	Micron ratings available	Code
Inorg. glass fibre	25 bar / 363 PSI	6, 10, 20	G
Filter paper	10 bar / 145 PSI	10	D

*Note: Collapse/burst resistance as per ISO 2941
Other materials on request

4 Micron Rating

6 μ m **06**
10 μ m **10**
20 μ m **20**

Note: Other micron ratings on request

5 Sealing Material

NBR (Buna®) **B**
FPM (Viton®) **V**
Note: Other sealing materials on request

6 Design Code

Only for information **X**

Return Line Filters ▪ Type RTF40

Product Description

STAUFF RTF40 Return Line Filters are designed as tank top filters with a maximum operating pressure of 6,9 bar / 100 PSI. The filter bowl is designed to return the oil beneath the surface thus preventing entrainment of air.

Technical Data
Construction

- Tank Top flange mounting

Materials

- Filter head: Aluminum
- Filter bowl: Bowl length 1: Polyamide
Bowl length 2: Steel
- Sealings: NBR (Buna-N®)
Other sealing materials on request

Port Connection

- BSP
- NPT
- SAE O-ring thread
- SAE flange

Flow Rating

- Up to 378 l/min / 100 US GPM

Operating Pressure

- Max. 6,9 bar / 100 psi

Temperature Range

- -25°C ...+95°C / -13°F ... +203°F

Filter Elements

- RTE-47 with integrated bypass valve, single stack length
- RTE-48 bypass valve integrated in the filter head, equivalent to the HF-4 elements, single and double stack lengths
- RTE-49 bypass valve integrated in the filter head, single and double stack lengths
- Specifications see page C106

Media Compatibility

- Mineral oils, other fluids on request

Options and Accessories
Valve

- Bypass valve: Opening pressures 1 bar / 14.5 PSI ±10 % or 1,7 bar / 25 PSI ±10 %
RTF47: Bypass intergrated in the filter element
RTF48/49: Bypass integrated in the filter head

Clogging Indicators

- Visual clogging indicator, coloured segments
- Electrical clogging switch, adjustable
Other clogging indicators available on request

Return Line Filters ▀ Type RTF40

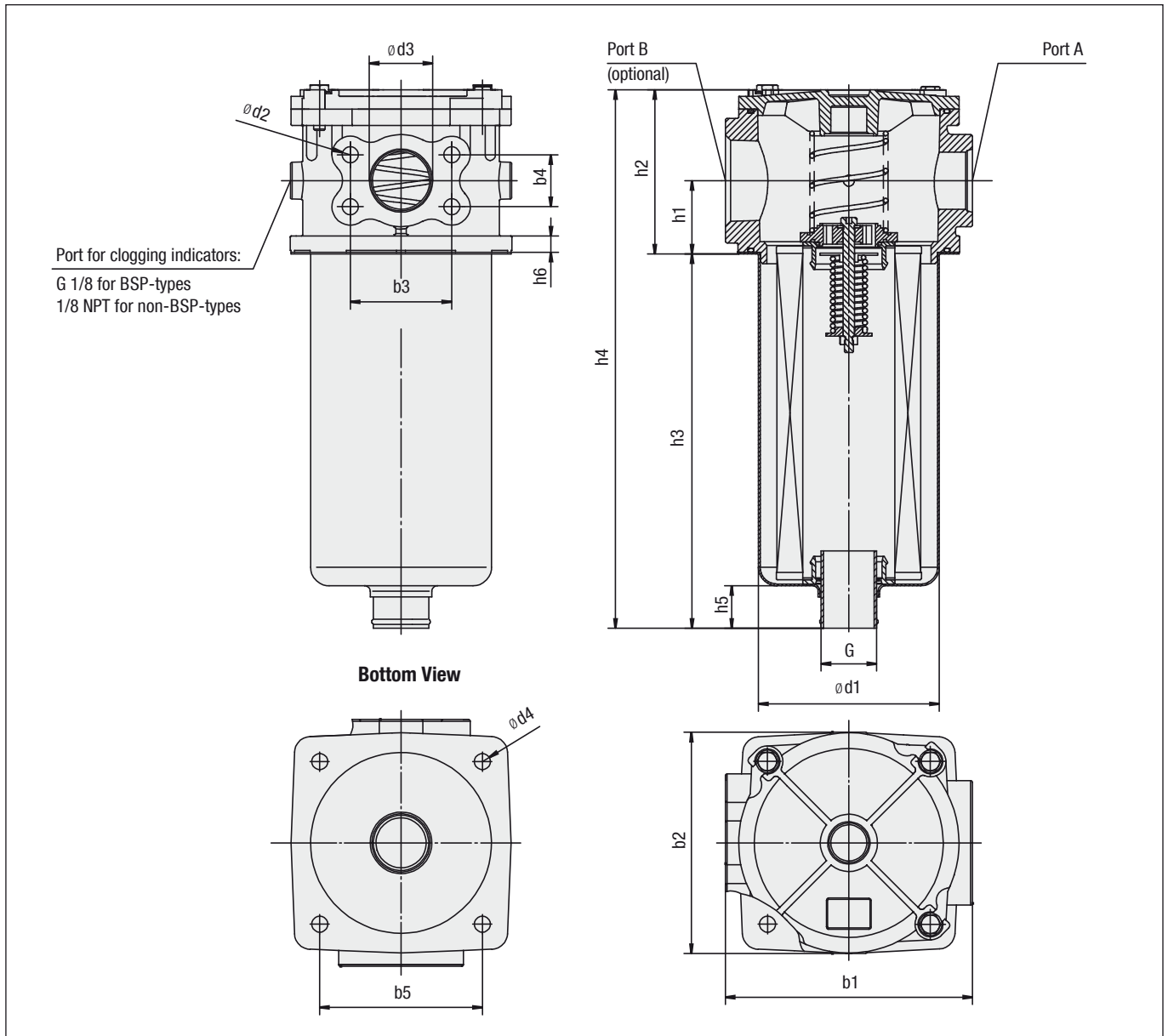

Return Line Filters ▀ Type RTF Accessories

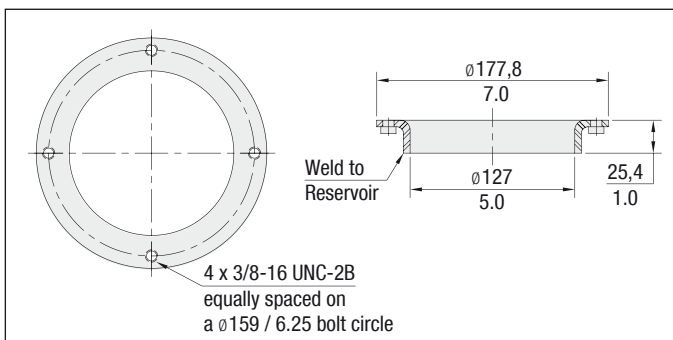

Dimensions in mm / in

RTF40 Series Weld Ring WR-40

The WR-40 weld ring is welded directly to the hydraulic reservoir, eliminating the need for drilling and tapping mounting holes in the reservoir.

Material: Carbon Steel

Return Line Filters ■ Type RTF40

Thread Connection Combinations	Filter Size RTF			
	4...S1		4...S2	
	Port A	Port B	Port A	Port B
BSP (B)	1-1/4 and 1-1/2 SAE Flange	None	1-1/4 and 1-1/2 SAE Flange	None
BSP (BB)	1-1/4 and 1-1/2 SAE Flange	1-1/4	1-1/4 and 1-1/2 SAE Flange	1-1/4
NPT (N)	1-1/4 and 1-1/2 SAE Flange	None	1-1/4 and 1-1/2 SAE Flange	None
NPT (NN)	1-1/4 and 1-1/2 SAE Flange	1-1/4	1-1/4 and 1-1/2 SAE Flange	1-1/4
NPT (M)	1-1/2	None	1-1/2	None
NPT (MN)	1-1/2	1-1/4	1-1/2	1-1/4
NPT (MM)	1-1/2	1-1/2	1-1/2	1-1/2
SAE (S)	1-5/8-12	None	1-5/8-12	None
SAE (SS)	1-5/8-12	1-5/8-12	1-5/8-12	1-5/8-12
SAE (ST)	1-5/8-12	1-7/8-12	1-5/8-12	1-7/8-12
SAE (SU)	1-5/8-12	2-1/2-12	1-5/8-12	2-1/2-12
SAE (TT)	1-7/8-12	1-7/8-12	1-7/8-12	1-7/8-12
Combination SAE & NPT (S0)	1-5/8-12	2	1-5/8-12	2

Dimensions (mm/in)	Filter Size RTF	
	4...S1	4...S2
h1	50	50
	1.97	1.97
h2	112	112
	4.41	4.41
h3	263	475
	10.35	18.70
h4	385	587
	15.16	23.11
h5	21	38
	.83	1.50
h6	11	11
	.43	.43
b1	170	170
	6.70	6.70
b2	152	152
	5.98	5.98
b3	69.9	69.9
	2.75	2.75
b4	35.6	35.6
	1.40	1.40
b5	112	112
	4.41	4.41
d1	122	122
	4.80	4.80
d2	M12 or 1/2-13 UN	M12 or 1/2-13 UN
	38,1 1.50	38,1 1.50
d3	11	11
	.43	.43
G	G1-1/2 or 1-1/2 NPT	G1-1/2 or 1-1/2 NPT

Return Line Filter Housings / Complete Filters ■ Type RTF40

RTF **48** **...** **...** **B** / **N** / **25** / **S2** / **V** / **X**

1 2 3 4 5 6 7 8 9 10

1 Type

Return Line Filter **RTF**

2 Group

Flow	Size
190 l/min / 50 US GPM	47
190 l/min / 50 US GPM	48
190 l/min / 50 US GPM	49

Note: Exact flow will depend on filter element selected.
Consult technical data on pages C115 / C116
For element length 2 (only RTF48 / RTF49) please double relating flow values.

3 Filter Material

Material	Max. Δp^* collapse	Micron ratings available	Code
Without filter element	-	-	...
Inorg. glass fibre	10 bar / 145 PSI	3, 5, 10, 25	G
Filter paper	10 bar / 145 PSI	3, 10, 25	D

*Note: Collapse/burst resistance as per ISO 2941
Other materials on request

4 Micron Rating

3 μ m	03
5 μ m	05
10 μ m	10
20 μ m	20
25 μ m	25

Note: Other micron ratings on request

5 Sealing Material

NBR (Buna®) **B**
Note: Other sealing materials on request

6 Connection Style

Connection Style	Group		Code
	Port A	Port B	
BSP	1-1/4 and 1-1/2 SAE Flange	None	B
BSP	1-1/4 and 1-1/2 SAE Flange	1-1/4	BB
NPT	1-1/4 and 1-1/2 SAE Flange	None	N
NPT	1-1/4 and 1-1/2 SAE Flange	1-1/4	NN
NPT	1-1/2	None	M
NPT	1-1/2	1-1/4	MN
NPT	1-1/2	1-1/2	MM
SAE	1-5/8-12	None	S
SAE	1-5/8-12	1-5/8-12	SS
SAE	1-5/8-12	1-7/8-12	ST
SAE	1-5/8-12	2-1/2-12	SU
SAE	1-7/8-12	1-7/8-12	TT
Combination NPT & SAE	1-5/8-12	2	SO

7 Valve

No bypass	00
1 bar / 15 PSI	15
1,7 bar / 24.6 PSI	25

8 Length

Bowl Length 1 (1 element)	S1
Bowl Length 2 (2 elements)	S2

Note: RTF 47 size available in S1 bowl length only.

9 Clogging Indicator

No clogging indicator	N
Visual clogging indicator	V
Electrical clogging indicator	E

Note: See pages C104 and C117 for more details on indicator ports and options

10 Design Code

Only for information	X
----------------------	----------

Filter Elements ■ Type RTE

RTE - **48** **D** **10** **B** / **X**

1 2 3 4 5 6

1 Type

Filter Element Series **RTE**

2 Group

According to filter housing

3 Filter Material

Material	Max. Δp^* collapse	Micron ratings available	Code
Inorg. glass fibre	10 bar / 145 PSI	3, 5, 10, 25	G
Filter paper	10 bar / 145 PSI	3, 10, 25	D

*Note: Collapse/burst resistance as per ISO 2941
Other materials on request

4 Micron Rating

3 μ m	03
5 μ m	05
10 μ m	10
20 μ m	20
25 μ m	25

Note: Other micron ratings on request

5 Sealing Material

NBR (Buna®) **B**
Note: Other sealing materials on request

6 Design Code

Only for information	X
----------------------	----------

Return Line Filters ■ Type RTF50

Product Description

STAUFF RTF50 Return Line Filters are designed for tank top applications with a maximum pressure of 6,9 bar / 100 PSI. The filter bowl is designed to return the oil beneath the surface thus preventing entrainment of air. The RTF58 elements interchange with the popular "K" series and RTF59 elements interchange with the "RE-409" series elements.

Technical Data
Construction

- Tank Top flange mounting

Materials

- Filter head: Aluminum
- Filter bowl: Bowl length 1: Polyamide
Bowl length 2: Steel
- Sealings: NBR (Buna-N®)
Other sealing materials on request

Port Connection

- BSP
- NPT
- SAE O-ring thread

Flow Rating

- Up to 379 l/min / 100 US GPM

Operating Pressure

- Max. 6,9 bar / 100 PSI

Temperature Range

- -25°C ...+95°C / -13°F ... +203°F

Filter Elements

- Specifications see page C110

Media Compatibility

- Mineral oils, other fluids on request

Options and Accessories
Valve

- Bypass valve: Opening pressures 1 bar / 14.5 PSI ±10 % or 1,7 bar / 25 PSI ±10 %
Other settings available on request

Clogging Indicators

- Visual clogging indicator, coloured segments
- Electrical clogging switch, adjustable
Other clogging indicators available on request

Return Line Filters ▪ Type RTF50

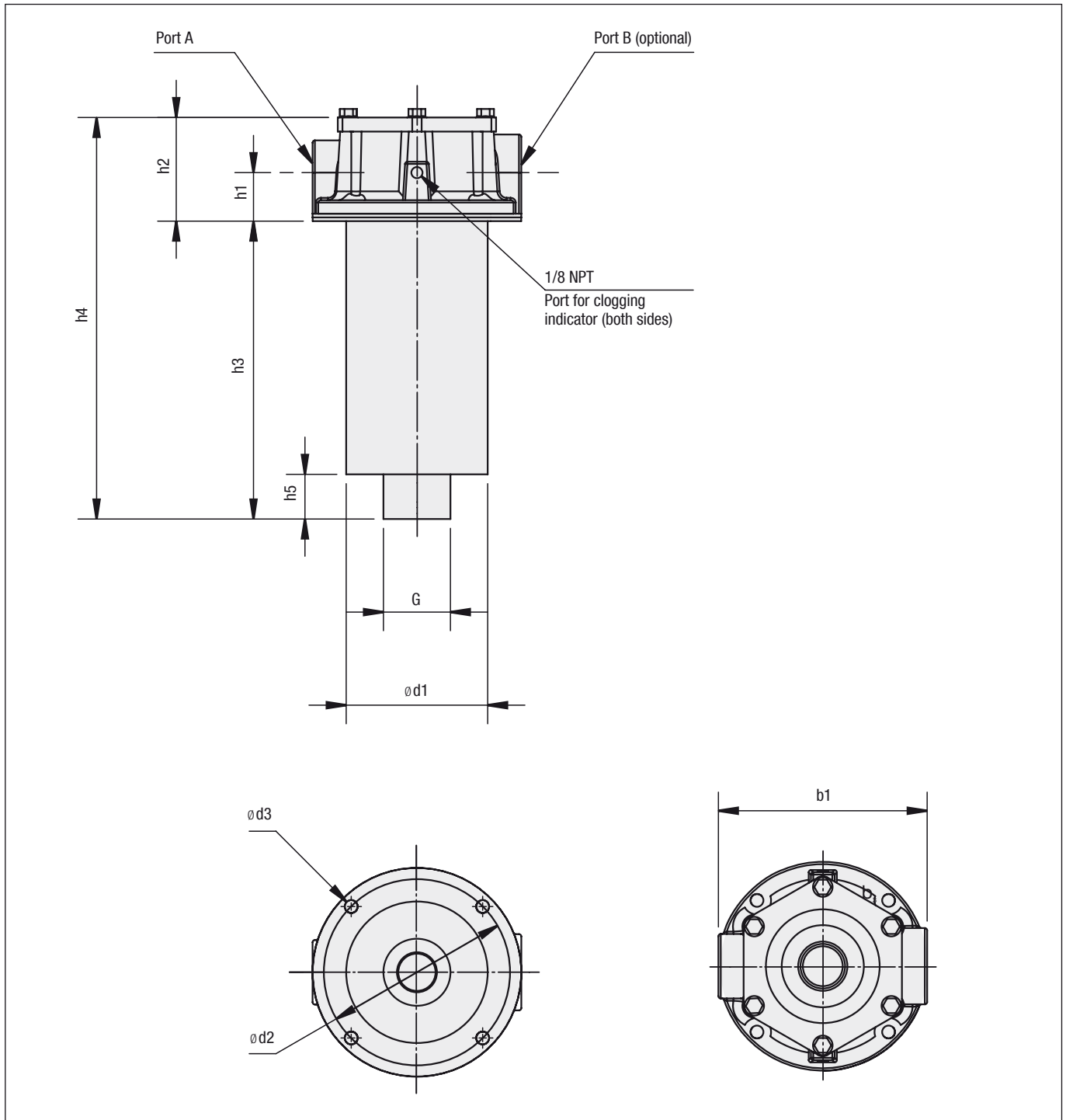

Return Line Filters ▪ Type RTF Accessories

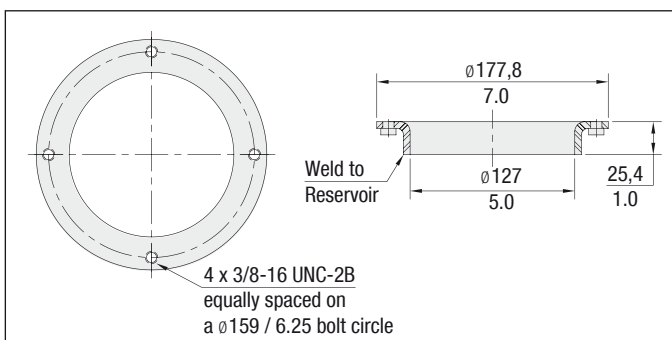

Dimensions in mm / in

RTF50 Series Weld Ring WR-40

The WR-40 weld ring is welded directly to the hydraulic reservoir, eliminating the need for drilling and tapping mounting holes in the reservoir.

Material: Carbon Steel

Return Line Filters ■ Type RTF50

Thread Connection Combinations	Filter Size RTF			
	5...S1		5...S2	
	Port A	Port B	Port A	Port B
NPT (N)	1-1/4	None	1-1/4	None
NPT (NM)	1-1/4	1-1/2	1-1/4	1-1/2
NPT (M)	None	1-1/2	None	1-1/2
Combination SAE & NPT (SM)	1-5/8-12	1-1/2	1-5/8-12	1-1/2
SAE (S)	1-5/8-12	None	1-5/8-12	None
SAE (T)	None	1-7/8-12	None	1-7/8-12
SAE (ST)	1-5/8-12	1-7/8-12	1-5/8-12	1-7/8-12
Combination NPT & SAE (NT)	1-1/4	1-7/8-12	1-1/4	1-7/8-12

Dimensions (mm/in)	Filter Size RTF	
	5...S1	5...S2
h1	49,3	42,3
	1,94	1,67
h2	95,5	88,5
	3,78	3,48
h3	241,3	485,9
	9,50	19,13
h4	336,8	574,9
	13,26	22,61
h5	29,5	38,1
	1,16	1,50
b1	177,8	177,8
	7,00	7,00
d1	124,8	124,8
	4,91	4,91
d2	158,7	158,7
	6,25	6,25
d3	11,2	11,2
	.44	.44
G	1-1/2 NPT	1-1/2 NPT

Return Line Filter Housings / Complete Filters ■ Type RTF50

RTF **58** **...** **...** **B** / **N** / **25** / **S2** / **V** / **X**

1 2 3 4 5 6 7 8 9 10

1 Type

Return Line Filter **RTF**

2 Group

Flow	Size
Group size 58	58
Group size 59	59

Note: Exact flow will depend on filter element selected.
Consult technical data on page C116

3 Filter Material

Material	Max. Δp^* collapse	Micron ratings available	Code
Without filter element	-	-	...
Inorg. glass fibre	10 bar / 145 PSI	3, 5, 10, 25	G
Filter paper	5 bar / 72.5 PSI	3, 10, 25	D

*Note: Collapse/burst resistance as per ISO 2941
Other materials on request

4 Micron Rating

3 μm	03
5 μm	05
10 μm	10
20 μm	20
25 μm	25

Note: Other micron ratings on request

5 Sealing Material

NBR (Buna®) **B**
Note: Other sealing materials on request

6 Connection Style

Connection Style	Group		Code
	Port A	Port B	
NPT	1-1/4	None	N
NPT	1-1/4	1-1/2	NM
NPT	None	1-1/2	M
Combination SAE & NPT	1-5/8-12	1-1/2	SM
SAE	1-5/8-12	None	S
SAE	None	1-7/8-12	T
SAE	1-5/8-12	1-7/8-12	ST
Combination NPT & SAE	1-1/4	1-7/8-12	NT

7 Valve

No bypass	00
1 bar / 15 PSI	15
1,7 bar / 24.6 PSI	25

8 Length

Bowl Length 1 (1 element)	S1
Bowl Length 2 (2 elements)	S2

9 Clogging Indicator

No clogging indicator	N
Visual clogging indicator	V
Electrical clogging indicator	E

Note: See pages C108 and C117 for more details on indicator ports and types

10 Design Code

Only for information **X**

Filter Elements ■ Type RTE

RTE - **58** **D** **10** **B** / **X**

1 2 3 4 5 6

1 Type

Filter Element Series **RTE**

2 Group

According to filter housing

3 Filter Material

Material	Max. Δp^* collapse	Micron ratings available	Code
Inorg. glass fibre	10 bar / 145 PSI	3, 5, 10, 25	G
Filter paper	5 bar / 72.5 PSI	3, 10, 25	D

*Note: Collapse/burst resistance as per ISO 2941
Other materials on request

4 Micron Rating

3 μm	03
5 μm	05
10 μm	10
20 μm	20
25 μm	25

Note: Other micron ratings on request

5 Sealing Material

NBR (Buna®) **B**
Note: Other sealing materials on request

6 Design Code

Only for information **X**

Return Line Filters ■ Type RTF-N

Product Description

STAUFF RTF-N Return Line Insert Filters allow for a choice of installation configurations which permits custom reservoir design with an in tank filtering system. The filters are installed semi-immersed or totally immersed into a reservoir. The filtration flow is from inside to the outside of the element which ensures that all the contaminant is collected inside the element itself avoiding contact with the reservoir fluid during element change. The combination of magnetic pre-filtration and high filtration efficiency results in a cost effective and versatile filtration system.

Technical Data
Construction

- Insert filter

Materials

- Flange plate: Aluminum
- Magnet rod: Steel
- Bypass: Steel
- Diffuser: Steel
- Sealings: NBR (Buna-N®)
FPM (Viton®)
Other sealing materials on request

Flow Rating

- Up to 500 l/min / 132 GPM

Operating Pressure

- Max. 10 bar / 145 PSI

Temperature Range

- -29°C ...+107°C / -20°F ... +225°F

Filter Elements

- Specifications see page C114

Media Compatibility

- Mineral oils, other fluids on request

Options and Accessories
Valve

- Bypass valve: Opening pressure 1,5 bar / 22 PSI
(integrated in the filter element) Other settings available on request

Return Line Filters - Type RTF-N

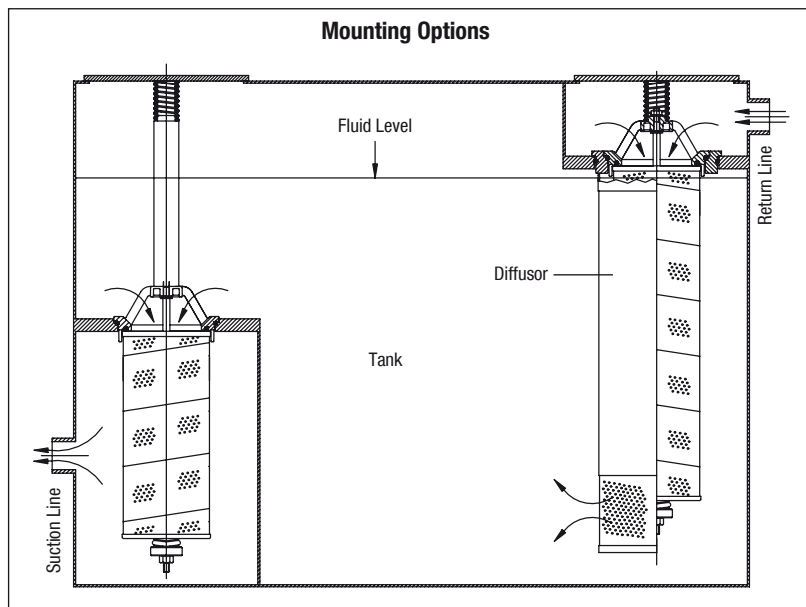
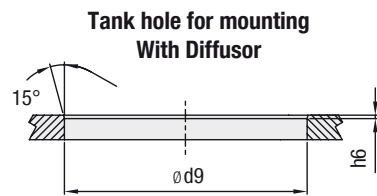
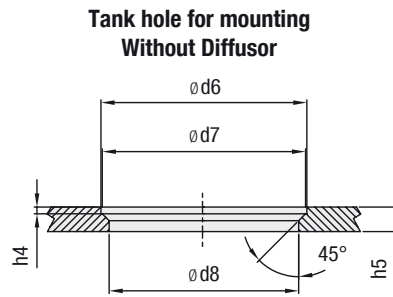
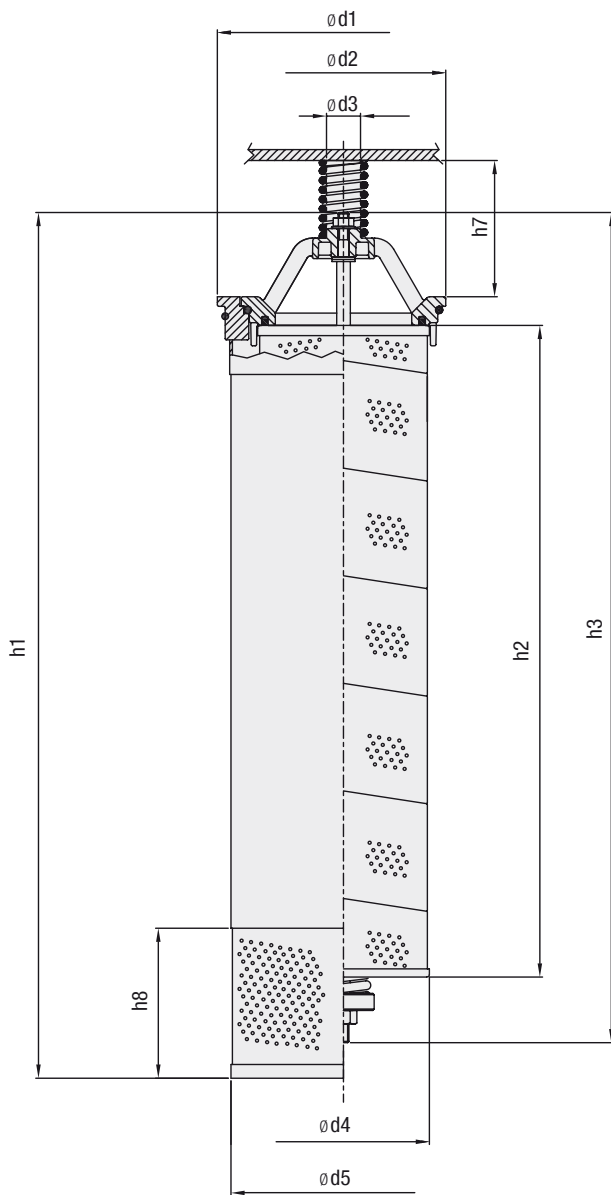

Return Line Filters ▀ Type RTF-N

Dimensions (mm/in)	Filter Size RTF-N	
	390	500
h1	445	635
	17.52	25.00
h2	290	478
	11.42	18.82
h3	421	609
	16.57	23.98
h4	5	5
	.20	.20
h5	18	18
	.71	.71
h6	2,5	2,5
	.10	.10
h7	100	100
	3.94	3.94
h8	110	110
	4.33	4.33
d1	185	185
	7.28	7.28
d2	150	150
	5.91	5.91
d3	25	25
	.98	.98
d4	126	126
	4.95	4.95
d5	165	165
	6.50	6.50
d6	151	151
	5.94	5.94
d7	149	149
	5.87	5.87
d8	139	139
	5.47	5.47
d9	178	178
	7.01	7.01

Return Line Filter Housings / Complete Filters ■ Type RTF-N

RTF-N **500** **...** **...** / **B** / **22** / **D** / **X**
1 **2** **3** **4** **5** **6** **7** **8**
1 TypeReturn Line Insert Filter **RTF-N****2** Group

Flow	Size
390 l/min / 103 GPM	390
500 l/min / 132 GPM	500

Note: Exact flow will depend on filter element selected.
Consult technical data on page C116

3 Filter Material

Material	Max. Δp^* collapse	Micron ratings available	Code
Without filter element	-	-	...
Inorg. glass fibre	10 bar / 145 PSI	3, 5, 10, 20	E
Filter paper	10 bar / 145 PSI	10	L

*Note: Collapse/burst resistance as per ISO 2941
Other materials on request

4 Micron Rating

3 μm	03
5 μm	05
10 μm	10
20 μm	20

Note: Other micron ratings on request

5 Sealing Material

NBR (Buna®)	B
FPM (Viton®)	V

Note: Other sealing materials on request

6 Bypass Setting

1,5 bar / 22 PSI	22
------------------	-----------

7 Options

Without diffusor	none
With diffusor	D

8 Design Code

Only for information	X
----------------------	----------

Filter Elements ■ Type RA

RA - **500** **E** **10** / **B** / **X**
1 **2** **3** **4** **5** **6**
1 TypeElement for Insert Filter **RA****2** Group

According to filter housing

3 Filter Material

Material	Max. Δp^* collapse	Micron ratings available	Code
Inorg. glass fibre	10 bar / 145 PSI	3, 5, 10, 20	E
Filter paper	10 bar / 145 PSI	10	L

*Note: Collapse/burst resistance as per ISO 2941
Other materials on request

4 Micron Rating

3 μm	03
5 μm	05
10 μm	10
20 μm	20

Note: Other micron ratings on request

5 Sealing Material

NBR (Buna®)	B
FPM (Viton®)	V

Note: Other sealing materials on request

6 Design Code

Only for information	X
----------------------	----------

Return Line Filters - Type RTF Flow Characteristics

The following characteristics are valid for mineral oils with a density of 0,85 kg/dm³ and the kinematic viscosity of 30 mm²/s (30cSt). The characteristics have been determined in accordance to ISO 3968. Multipass filter ratings have been obtained in accordance to ISO 16889. The housing pressure drop is directly proportional to the oil density. Consult STAUFF for details.

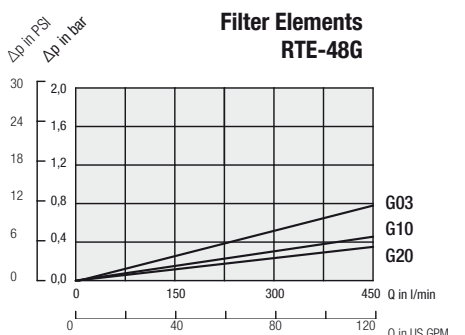
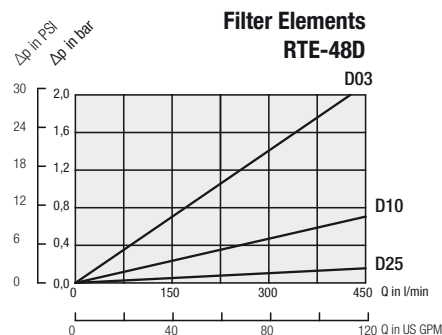
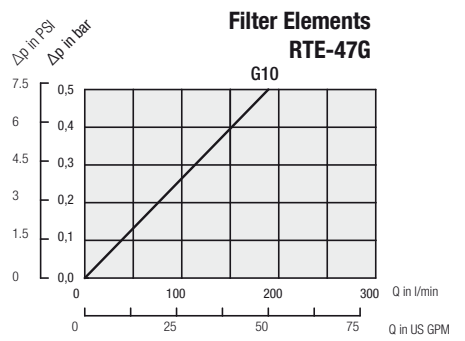
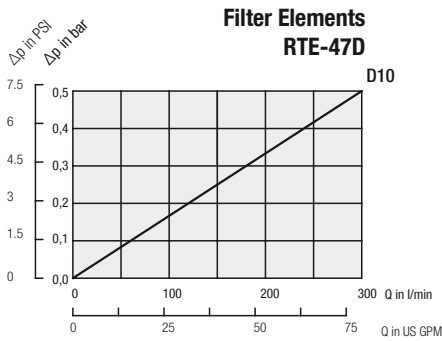
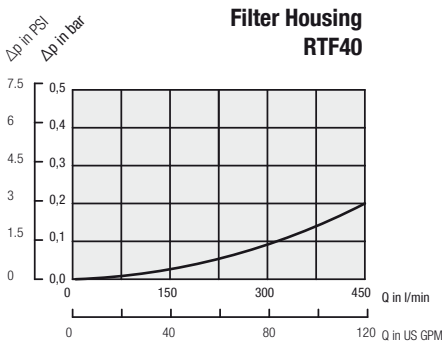
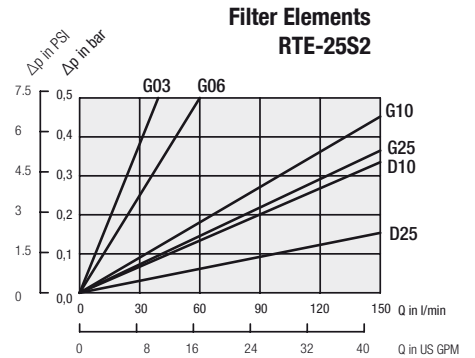
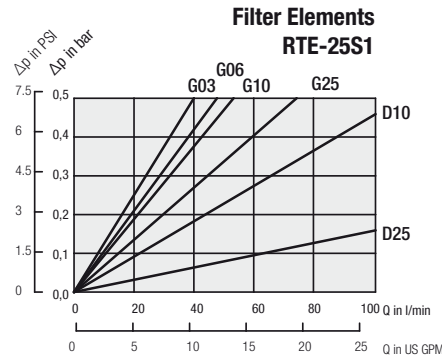
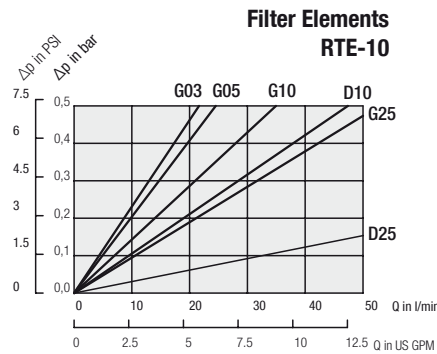
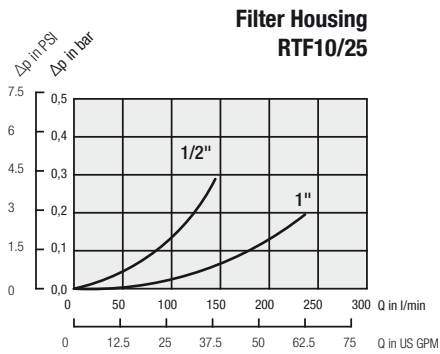
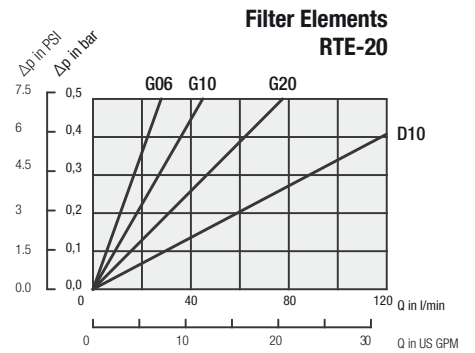
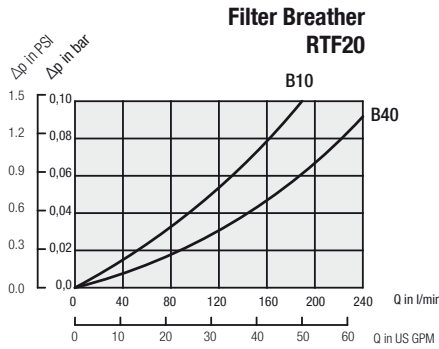
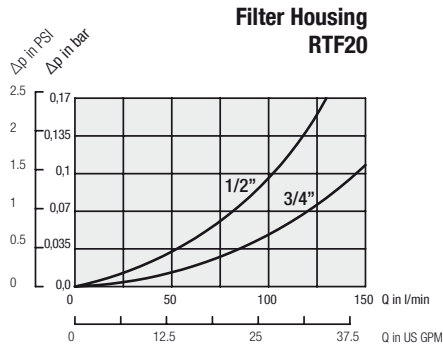

Return Line Filters - Type RTF Flow Characteristics

The following characteristics are valid for mineral oils with a density of 0,85 kg/dm³ and the kinematic viscosity of 30 mm²/s (30cSt). The characteristics have been determined in accordance to ISO 3968. Multipass filter ratings have been obtained in accordance to ISO 16889. The housing pressure drop is directly proportional to the oil density. Consult STAUFF for details.

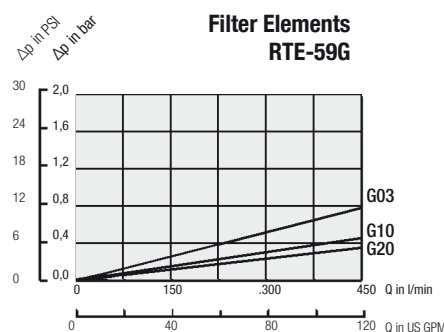
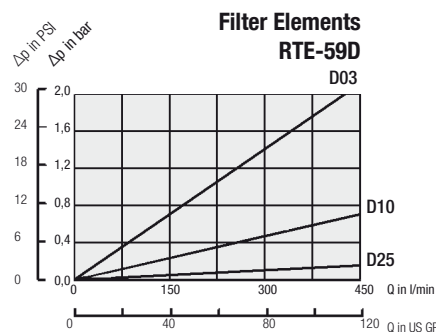
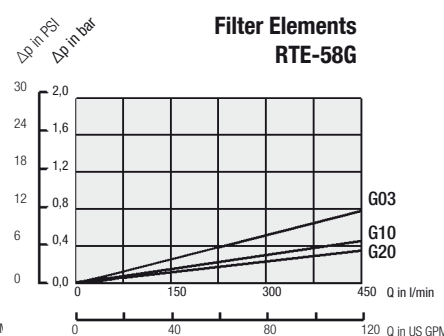
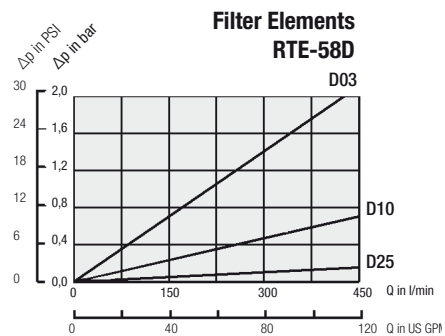
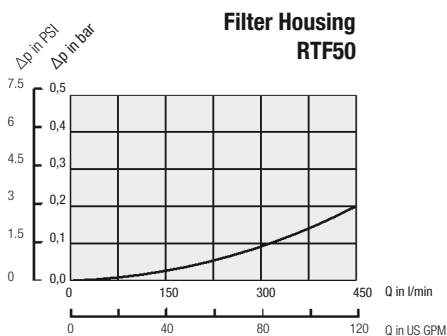
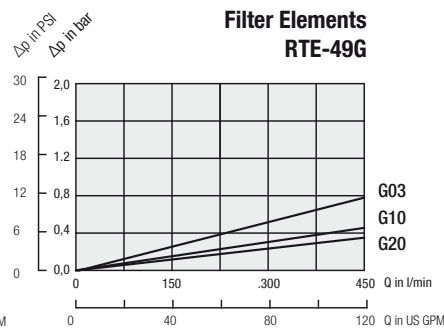
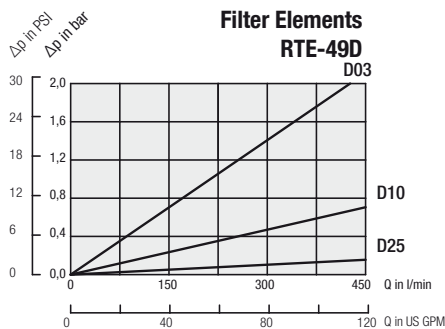

Note: Element pressure drop curves are for "S1" single elements. For "S2" double elements use 50% of the "S1" Value.

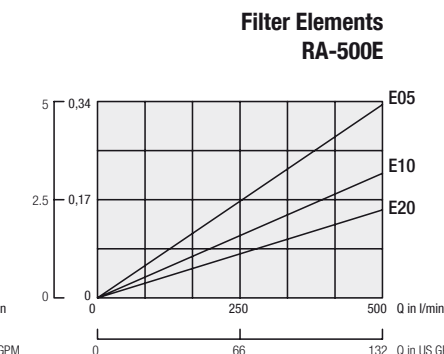
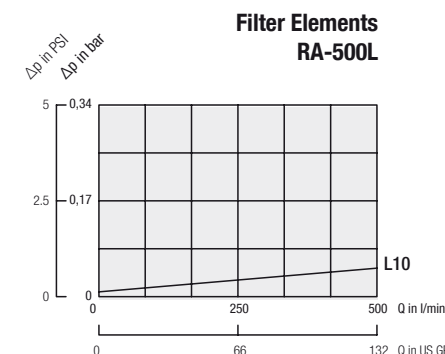
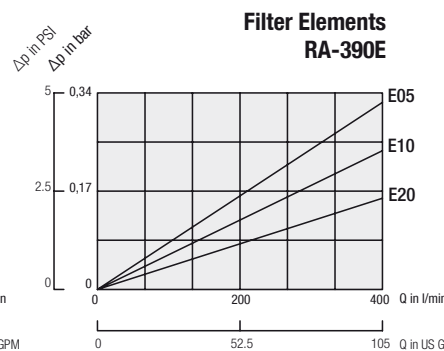
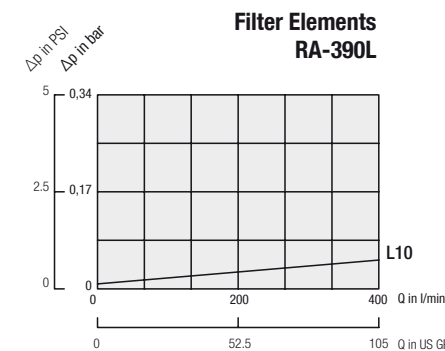
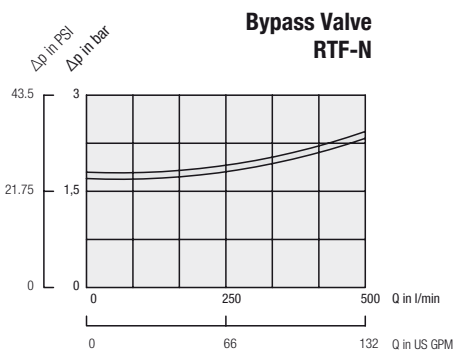

RTF Filter Indicators

Visual Indicators



SIM-04



CI-12

Visual Pressure Clogging Indicators

	Type	Thread Connection G	Unit of scale	Range of scale	Coloured Segments		
					Green	Yellow	Red
BSP	SIM-02	1/8	bar	0 ... 2,5	0 ... 1,2	1,2 ... 1,5	1,5 ... 2,5
	SIM-04	1/8	bar	0 ... 4	0 ... 2,5	2,5 ... 3	3 ... 4
	SIM-12	1/8	bar	0 ... 12	without coloured segments		
NPT	CI-12	1/8	PSI	0 ... 100	0 ... 13	13 ... 15	15 ... 100
	CI-20	1/8	PSI	0 ... 100	0 ... 21	21 ... 25	25 ... 100

Electrical Indicators



SIE-NO/NC



EPS

Electrical Clogging Indicators

	Type	Thread Connection G	Unit of scale	Adjustable range / Actuating pressure	Max. over pressure
BSP	SIE-NO	1/8	bar	1,3 (normally open)	80 bar / 1160 PSI
	SIE-NC	1/8	bar	1,3 (normally closed)	80 bar / 1160 PSI
	EPS-1B	1/8	bar	0,35 ... 2,5	25 bar / 362 PSI
NPT	EPS-1	1/8	PSI	5 ... 35	24 bar / 350 PSI

Technical Data SIE / EPS

	Type EPS-1 / 1B
Electrical data	6 Amp 125/250 V AC
Protection	DIN 43650 IP65
Temperature Range	-5°C ... +90°C / +23°F ... +194°F (ambient and media)
Diaphragm Material	NBR
Housing Material	Brass
Adjustable Range	0,35 bar ... 2,0 bar / 5 ... 30 PSI
Dead Band	20% F.S.
Weight	0,1 kg / .22 lbs
Repeatability	± 2 %
Hirschmann Connector With Strain Relief	

	Type SIE (electrical switch)
Electrical data	48V
Protection	DIN 43650 IP54
Temperature Range	-5°C ... +60°C / 23°F ... +140°F (ambient and media)
Diaphragm Material	NBR
Housing Material	Brass
Actuating Pressure	1,3 bar / 19 PSI
Max. current (res.)	0,5 A
Max. current (ind.)	0,2 A
Available as "normally open" (closes contact at actuating pressure) and as "normally closed" (opens contact at actuating pressure)	

Dimensions

Type SIM

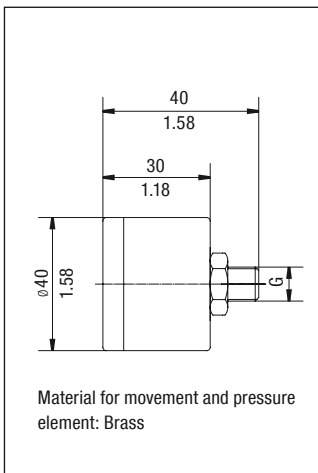

Type CI

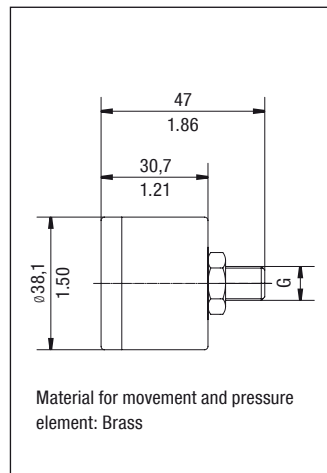

Type SIE

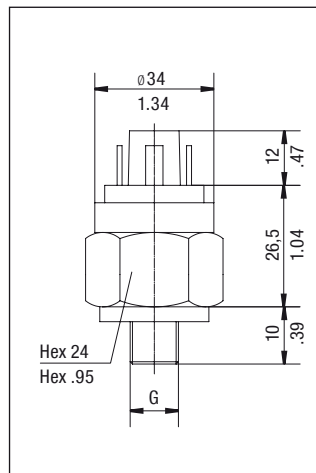

Type EPS

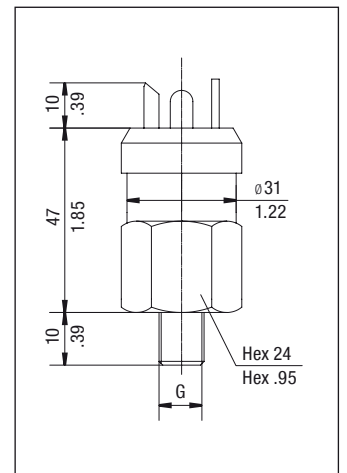

Dimensions in mm/in

Spin-On Filters ■ Introduction



Product Description

STAUFF provides a complete range of Spin-On filters which can be used either as suction filters or as return line filters for low pressure applications. The various ranges meet international standards. The corresponding STAUFF Filter Elements are available from stock.

Technical Data

Material

- Filter head: Aluminium
- Sealings: NBR (Buna-N®)

Port Connection

- BSP
 - NPT
 - SAE Flange
 - SAE O-ring thread
- Other port connections on request

Operating Pressure

- Up to 14 bar / 200 PSI

Nominal Flow Rate

- Up to 460 l/min / 120 US GPM

Options and Accessories

Clogging Indicators

- Visual clogging indicator with coloured segments
 - Electrical clogging switch
- Other types available on request

Private Labelling

- On request, the filter elements can be printed with a private label

Private Labeling

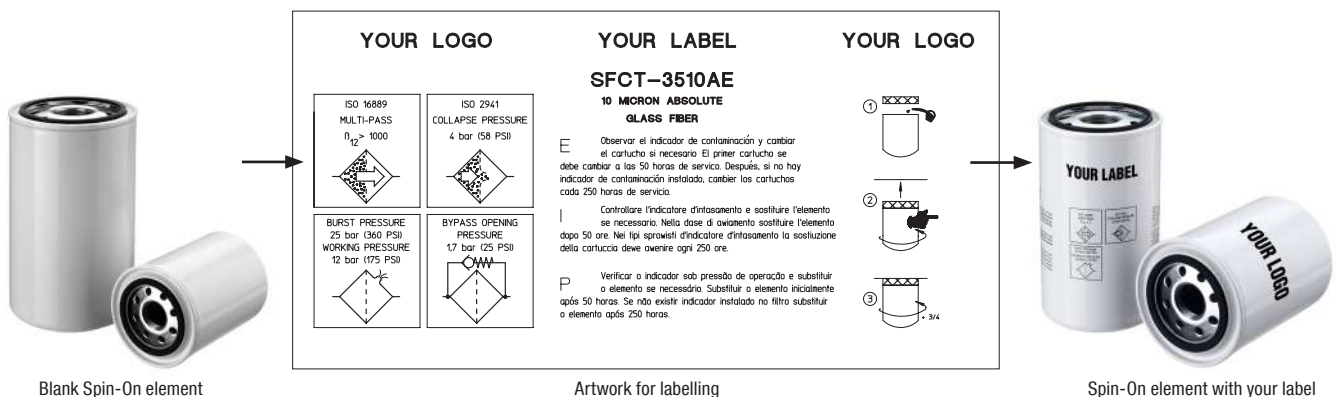

Spin-On Filters ■ Quick Reference Guide

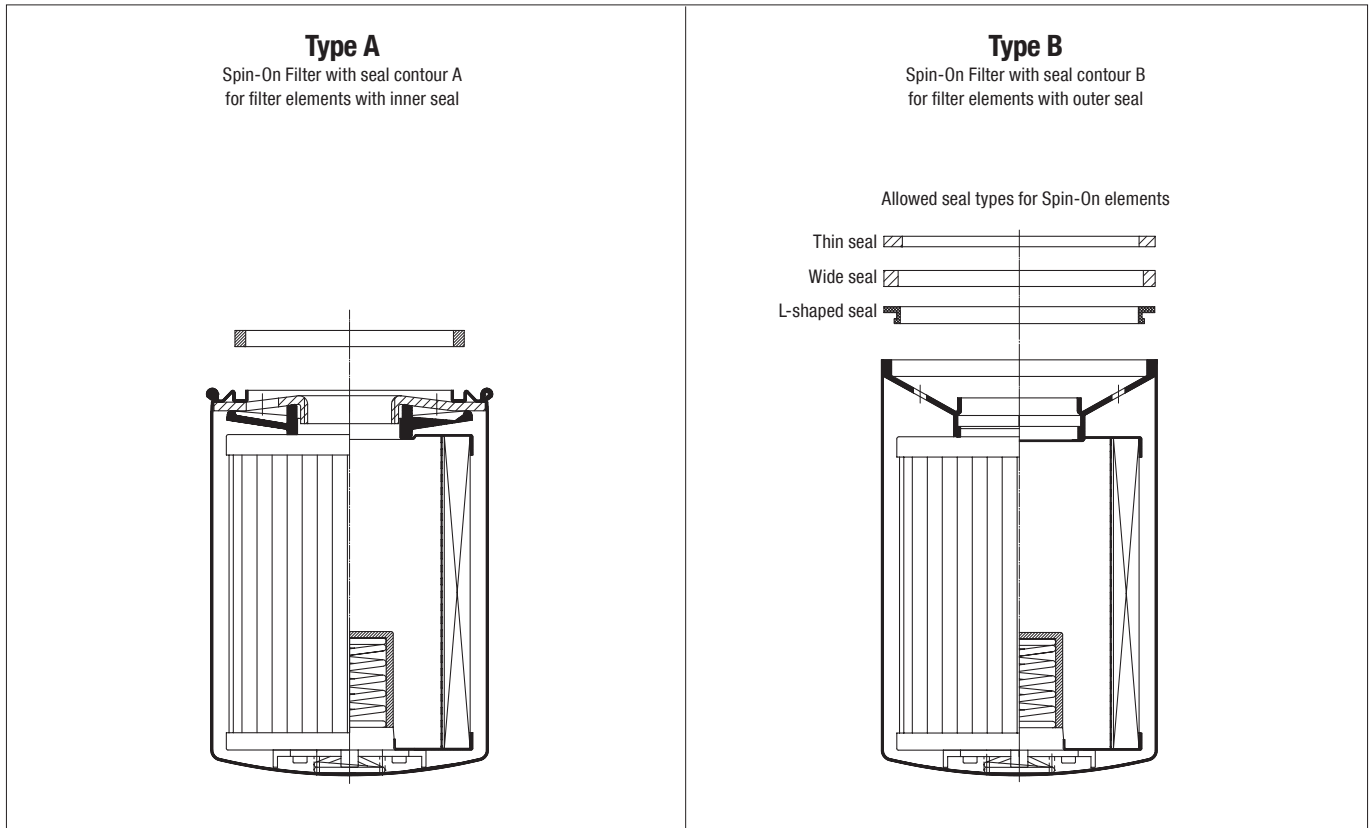

Spin on Filters Quick Reference Guide															
Spin-On Filter Heads								Spin-On Filter Elements (see page ...)							
Series	Size	Port	Spigot	Max. Flow Rate*		Catalog Page	Seal Contour		SF63	SF65	SF67	SFC-35 SFC-36	SFC-57 SFC-58	SFCT-35 SFCT-36	SFCT-57 SFCT-58
				l/min	US GPM		Type A	Type B							
SLF	02	1/4 NPT	3/4-16 UNF	19	5	C120	x		C137						
SLF	03	3/8 NPT	3/4-16 UNF	19	5	C120	x		C137						
SLF	04	9/16-18 UN	3/4-16 UNF	26	7	C120	x		C137						
SAF	05	1/2 NPT	1-12 UNF	57	15	C121	x			C138					
SAF	06	3/4-16 UN	1-12 UNF	57	15	C121	x			C138					
SAF	07	3/4 NPT	1-12 UNF	90	25	C121	x			C138					
SAF	11	1-1/16-12 UN	1-12 UNF	90	25	C121	x			C138					
SAF	10	1 NPT	1-12 UNF	128	34	C122	x			C138					
SAF	13	1-5/16-12 UN	1-12 UNF	128	34	C122	x			C138					
SSF	12	G3/4	G3/4	90	25	C123	x					C135			
SSF	20L	G1-1/4	G1-1/4 + 1-1/2-16 UN	225	60	C124	x	x			C139		C136		
SSF	100	1 NPT	G1-1/4 + 1-1/2-16 UN	170	45	C125	x	x			C139		C136		
SSF	120L	1-1/4 NPT	G1-1/4 + 1-1/2-16 UN	225	60	C125	x	x			C139		C136		
SSF	120	1-1/4 NPT	G1-1/4 + 1-1/2-16 UN	225	60	C125	x	x			C139		C136		
SSF	130	1-5/16-12 UN	G1-1/4 + 1-1/2-16 UN	225	60	C125	x	x			C139		C136		
SSF	160	1-5/8-12 UN	G1-1/4 + 1-1/2-16 UN	225	60	C125	x	x			C139		C136		
SSF	150	1-1/2 NPT	1-1/2-16 UN	300	80	C126		x			C139				
SSF	180	1-7/8-12 UN	1-1/2-16 UN	300	80	C126		x			C139				
SSF	24B	G1-1/2	G1-1/4 + 1-1/2-16 UN	454	120	C127	x	x			C139		C136		
SSF	24N	1-1/2 NPT	G1-1/4 + 1-1/2-16 UN	454	120	C128	x	x			C139		C136		
SSF	24S	1-7/8-12 UN	G1-1/4 + 1-1/2-16 UN	454	120	C128	x	x			C139		C136		
SSF	25B	G1-1/4 and 1-1/2 SAE Flange	G1-1/4 + 1-1/2-16 UN	454	120	C129	x	x			C139		C136		
SSF	25	1-1/2 NPT and 2 SAE Flange	G1-1/4 + 1-1/2-16 UN	454	120	C130	x	x			C139		C136		
SSFT	12B	G3/4	G3/4	75	20	C131	x	x						C135	
SSFT	12	3/4 NPT	G3/4	75	20	C132	x	x						C135	
SSFT	20B	G1-1/2	G1-1/4 + 1-1/2-16 UN	200	53	C133	x								C136
SSFT	20	1-1/2 NPT	G1-1/4 + 1-1/2-16 UN	200	53	C134	x								C136

* Note: Reflects nominal flow rate for return line application. Actual flow rate will depend on selected element and the viscosity of the fluid.

Spin-On Filter Heads ■ SAF-05 / 06 / 07 / 11

Dimensions

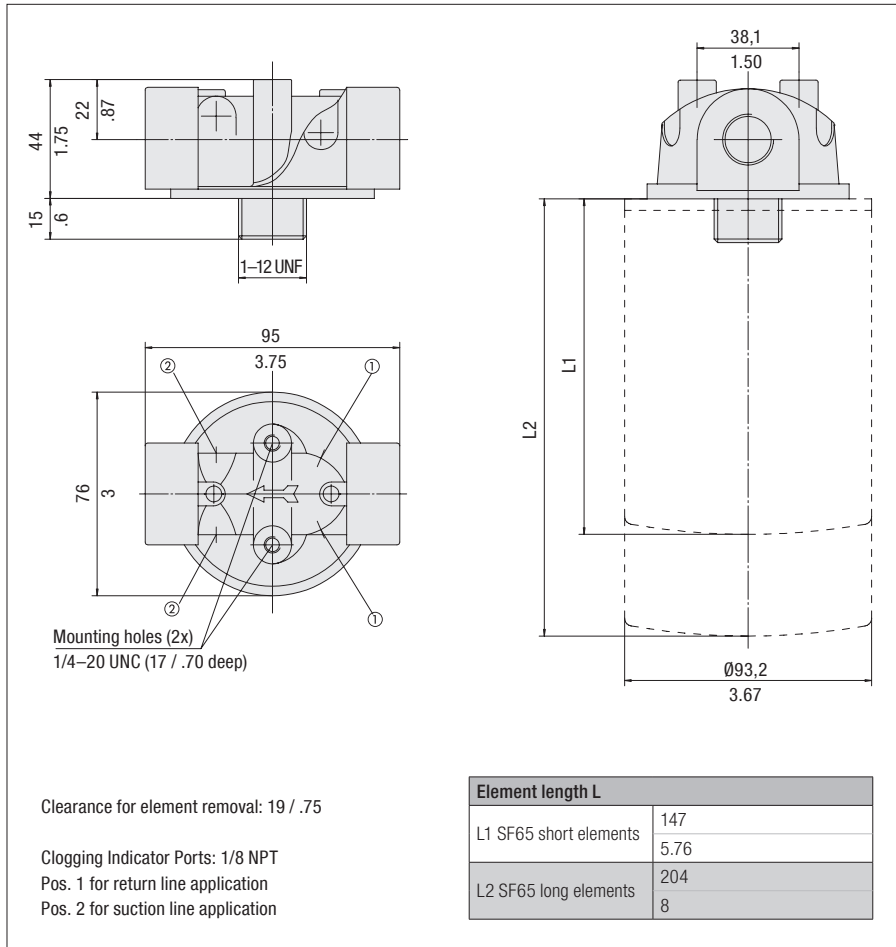

Dimensions in mm / in



Technical Data

Construction

- In-line Spin-On filter head

Material

- Aluminium

Port Connection

- NPT
- SAE O-ring thread

Flow Rate

- 90 l/min / 25 US GPM for return line application
- 23 l/min / 6 US GPM for suction line application

Operating Pressure

- Max. 14 bar / 200 PSI
- Max. 5,5 bar / 80 PSI differential pressure (for any application with no bypass valve)

Temperature Range

- -32°C ... +100°C / -25°F ... +212°F

Media Compatibility

- Mineral oils, other fluids on request

Options and Accessories

Filter Elements

- For use with SF65 series elements
- For element types with seal contour type A
- For element types and flow characteristics see page C138
- The element is not part of the scope of delivery

Valve

- Bypass valve (integrated in the head): Optional

Clogging Indicators

- Visual clogging indicator with coloured segments
- Electrical clogging switch 0,35 ... 2,5 bar / 5 ... 35 PSI adjustable
- For clogging indicator types see page C143

Order Code

SAF - 07 - 25 - 0

1 2 3 4

1 Type

 Spin-On Filter Head **SAF**
2 Connection Style

Connection	Thread	Code
NPT	1/2	05
SAE	3/4-16	06
NPT	3/4	07
SAE	1-1/16-12	11

3 Bypass Options

No bypass	00
0,2 bar / 3 PSI	03
0,35 bar / 5 PSI	05
1 bar / 15 PSI	15
1,7 bar / 25 PSI	25

4 Clogging Indicator Port Options

No clogging indicator port	0
Clogging indicator port drilled for return line application	1
Clogging indicator port drilled for suction line application	2
All clogging indicator ports drilled	4
Special	9

Note: Standard clogging indicator port is 1/8 NPT.

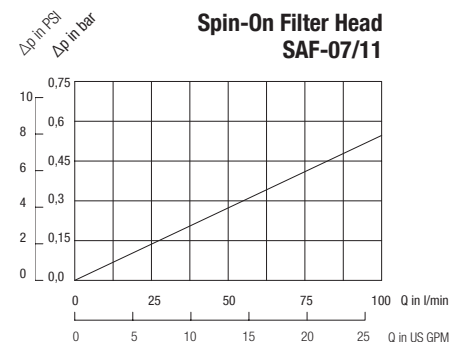
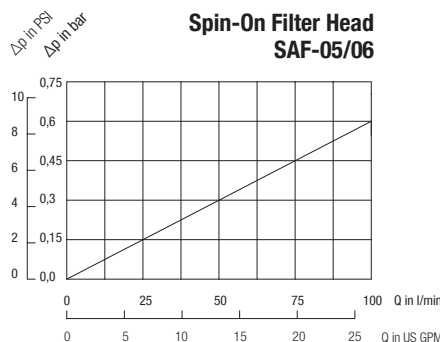

Spin-On Filter Heads ■ SAF-10 / 13



Dimensions

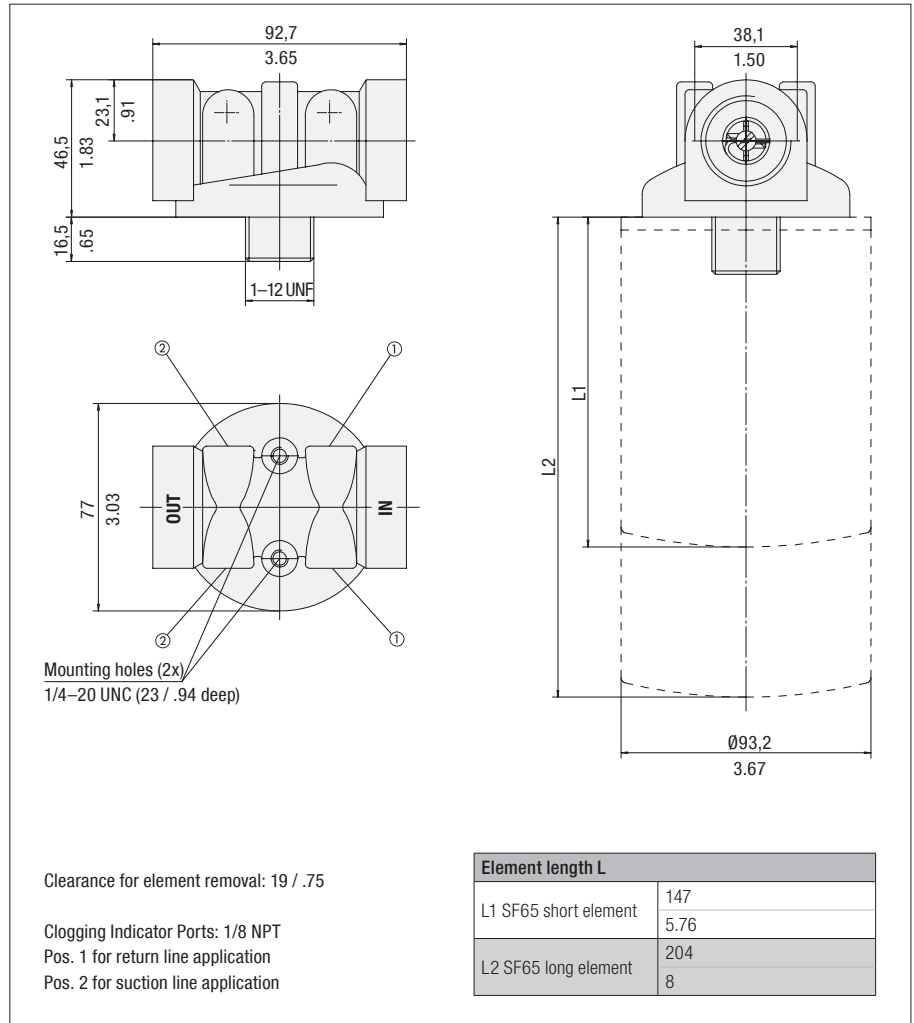

Dimensions in mm / in

Technical Data

Construction

- In-line Spin-On filter head

Material

- Aluminium

Port Connection

- NPT
- SAE O-ring thread

Flow Rate

- 128 l/min / 34 US GPM for return line application
- 30 l/min / 8 US GPM for suction line application

Operating Pressure

- Max. 14 bar / 200 PSI
- Max. 5,5 bar / 80 PSI differential pressure (for any applicaton with no bypass valve)

Temperature Range

- -32°C ... +100°C / -25°F ... +212°F

Media Compatibility

- Mineral oils, other fluids on request

Options and Accessories

Filter Elements

- For use with SF65 series elements
- For element types with seal contour type A
- For element types and flow characteristics see page C138
- The element is not part of the scope of delivery

Valve

- Bypass valve (integrated in the filter head): Optional

Clogging Indicators

- Visual clogging indicator with coloured segments
- Electrical clogging switch 0,35 ... 2,5 bar / 5 ... 35 PSI adjustable
- For clogging indicator types see page C143

Order Code

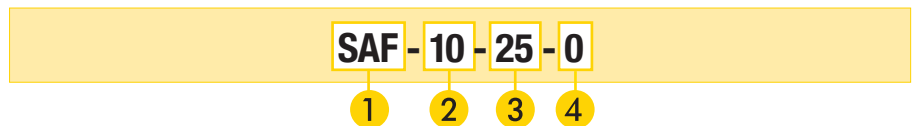

1 Type

Spin-On Filter Head	SAF
---------------------	-----

2 Connection Style

Connection	Thread	Code
NPT	1	10
SAE	1-5/16-12	13

3 Bypass Options

No bypass	00
0,2 bar / 3 PSI	03
0,35 bar / 5 PSI	05
1 bar / 15 PSI	15
1,7 bar / 25 PSI	25

4 Clogging Indicator Port Options

No clogging indicator port	0
Clogging indicator port drilled for return line application	1
Clogging indicator port drilled for suction line application	2
All clogging indicator ports drilled	4
Special	9

Note: Standard clogging indicator port is 1/8 NPT.

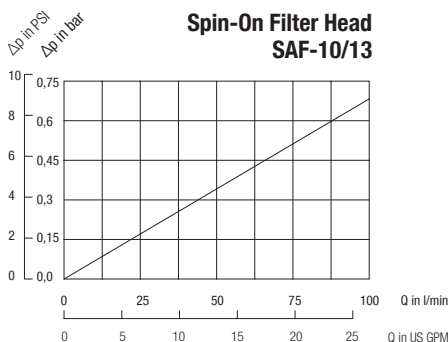

Spin-On Filter Heads ■ SSF-12

Dimensions

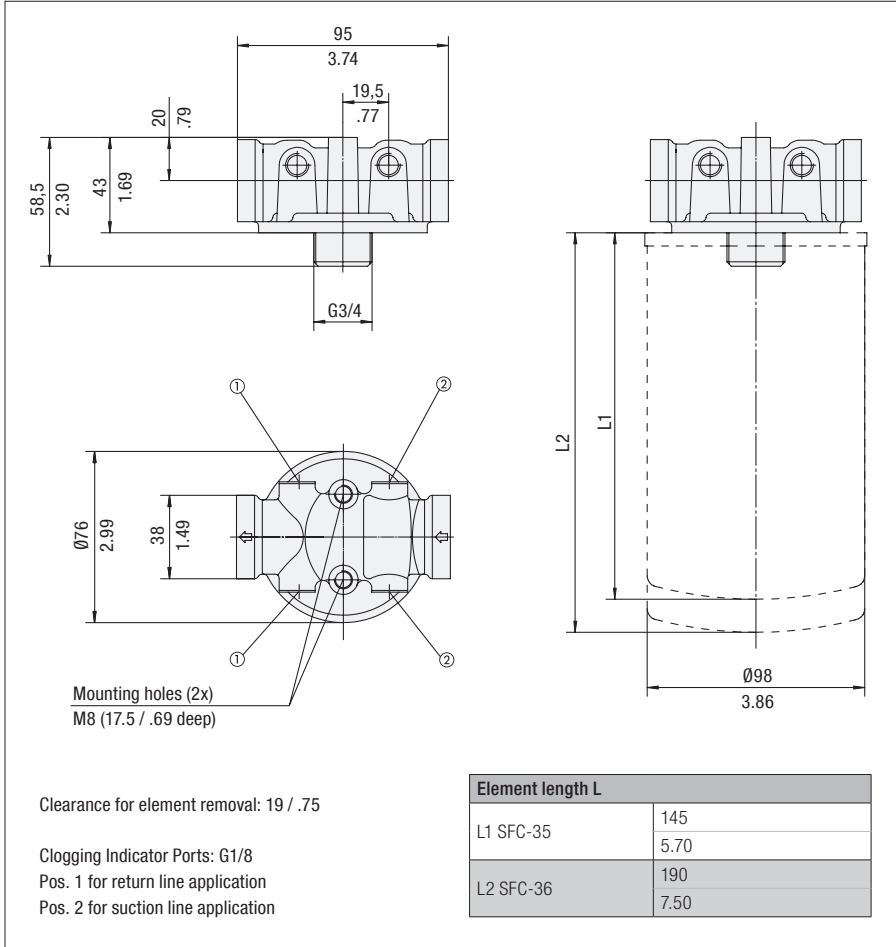

Technical Data

Construction

- In-line Spin-On filter head

Material

- Aluminium

Port Connection

- BSP

Flow Rate

- 90 l/min / 25 US GPM for return line application
- 23 l/min / 6 US GPM for suction line application

Operating Pressure

- Max. 12 bar / 174 PSI
- Max. 4 bar / 58 PSI differential pressure (for any application with no bypass valve)

Temperature Range

- -32°C ... +100°C / -25°F ... +212°F

Media Compatibility

- Mineral oils, other fluids on request

Options and Accessories

Filter Elements

- For use with SFC-35/36 series elements
- For element types with seal contour type A
- For element types and flow characteristics see page C135
- The element is not part of the scope of delivery

Valve

- Bypass valve (integrated in the filter head): Optional

Clogging Indicators

- Visual clogging indicator with coloured segments
- Electrical clogging switch 1,3 bar / 19 PSI adjustable
- For clogging indicator types see page C143

Order Code

SSF - 12 - 25 - 4

1 2 3 4

1 Type

 Spin-On Filter Head **SSF**
2 Connection Style

Connection	Thread	Code
BSP	3/4	12

3 Bypass Options

No bypass	00
0,2 bar / 3 PSI	03
1,7 bar / 25 PSI	25

Note: Other settings available on request.

4 Clogging Indicator Port Options

All clogging indicator ports drilled	4
Special	9

Note: Standard clogging indicator port is G1/8.

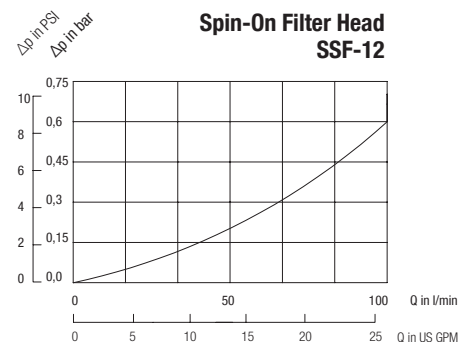

Spin-On Filter Heads ■ SSF-20L



Technical Data

Construction

- In-line Spin-On filter head

Material

- Aluminium

Port Connection

- BSP

Flow Rate

- 225 l/min / 60 US GPM for return line application
- 46 l/min / 12 US GPM for suction line application

Operating Pressure

- Max. 12 bar / 174 PSI
- Max. 4 bar / 58 PSI differential pressure (for any applicaton with no bypass valve)

Temperature Range

- -32°C ... +100°C / -25°F ... +212°F

Media Compatibility

- Mineral oils, other fluids on request

Options and Accessories

Filter Elements

- For use with SF67 and SFC-57/58 series elements
- For element types with seal contour type A and B
- For element types and flow characteristics see page C139 for SF67 and page C136 for SFC-57/58.
- The element is not part of the scope of delivery

Valve

- Bypass valve (integrated in the filter head): Optional

Clogging Indicators

- Visual clogging indicator with coloured segments
- Electrical clogging switch 0,35 ... 2,5 bar / 5 ... 35 PSI adjustable
- For clogging indicator types see page C143

Dimensions

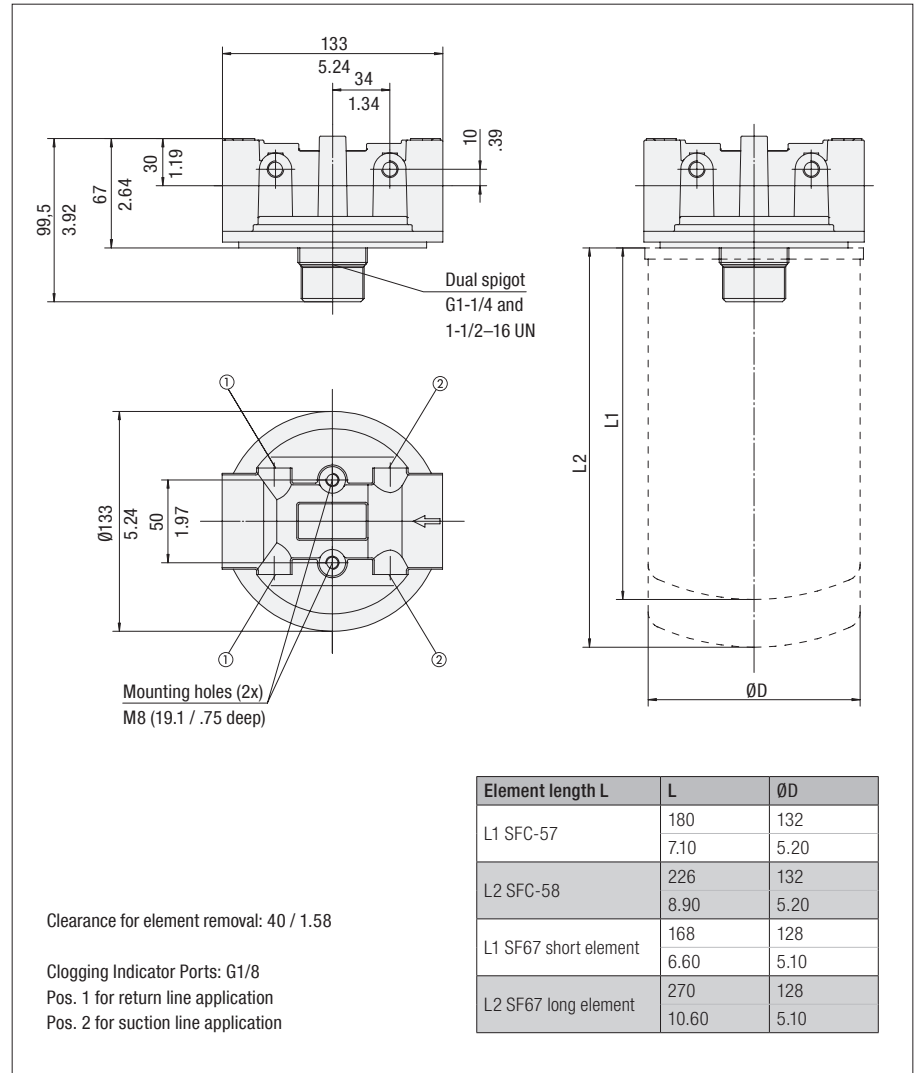

Dimensions in mm / in

Order Code

SSF - 20L - 25 - 4

1
2
3
4

1 Type

Spin-On Filter Head **SSF**

2 Connection Style

Connection	Thread	Code
BSP	1-1/4	20L

3 Bypass Options

No bypass	00
0,2 bar / 3 PSI	03
1,7 bar / 25 PSI	25

Note: Other settings available on request.

4 Clogging Indicator Port Options

All clogging indicator ports drilled	4
Special	9

Note: Standard clogging indicator port for is G1/8.

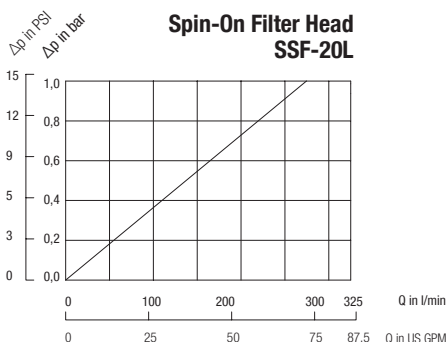

Spin-On Filter Heads ■ SSF-100 / 120 / 120L / 130 / 160

Dimensions

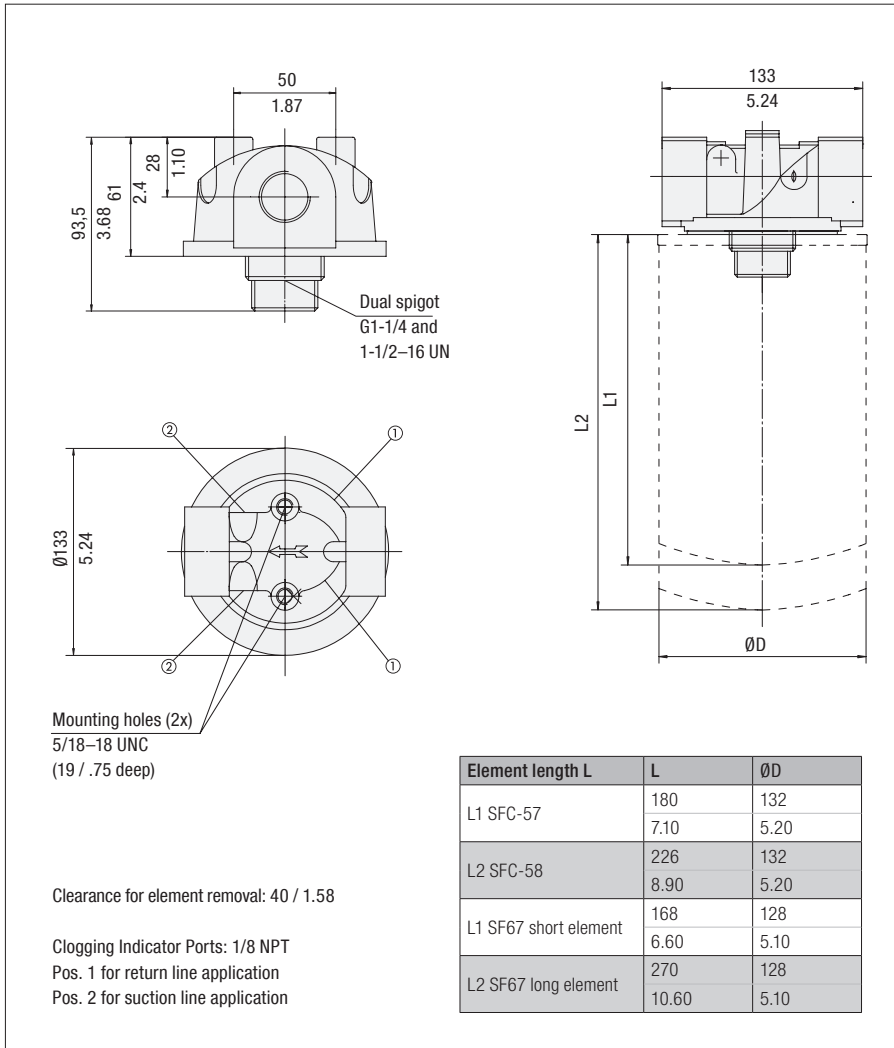

Technical Data

Construction

- In-line Spin-On filter head

Material

- Aluminium

Port Connection

- NPT
- SAE O-ring thread

Flow Rate

- 225 l/min / 60 US GPM for return line application
- 46 l/min / 12 US GPM for suction line application

Operating Pressure

- Max. 14 bar / 200 PSI
- Max. 5,5 bar / 80 PSI differential pressure (for any application with no bypass valve)

Temperature Range

- -32°C ... +100°C / -25°F ... +212°F

Media Compatibility

- Mineral oils, other fluids on request

Options and Accessories
Filter Elements

- For use with SF67 and SFC-57/58 series elements
- For element types with seal contour type A and B
- For element types and flow characteristics see page C139 for SF67 and page C136 for SFC-57/58.
- The element is not part of the scope of delivery

Valve

- Bypass valve (integrated in the filter head): Optional

Clogging Indicators

- Visual clogging indicator with coloured segments
- Electrical clogging switch 0,35 ... 2,5 bar / 5 ... 35 PSI adjustable
- For clogging indicator types see page C143

Order Code

SSF - 120 - 25 - 0

1 Type

 Spin-On Filter Head **SSF**
2 Connection Style

Connection	Thread	Code
NPT	1	100
NPT	1-1/4	120L
NPT	1-1/2	120
SAE	1-5/16-12	130
SAE	1-5/8-12	160

3 Bypass Options

No bypass	00
0,2 bar / 3 PSI	03
0,35 bar / 5 PSI	05
1 bar / 15 PSI	15
1,7 bar / 25 PSI	25

4 Clogging Indicator Port Options

No clogging indicator port	0
Clogging indicator port drilled for return line application	1
Clogging indicator port drilled for suction line application	2
All clogging indicator ports drilled	4
Special	9

Note: Standard clogging indicator port is 1/8 NPT.

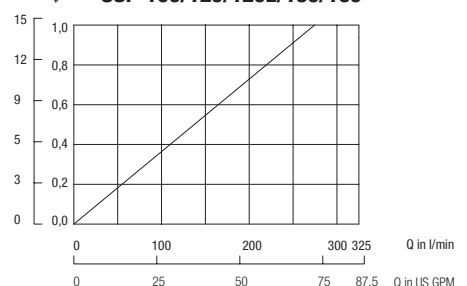
 Spin-On Filter Head
 SSF-100/120/120L/130/160

Spin-On Filter Heads ■ SSF-150 / 180



Dimensions

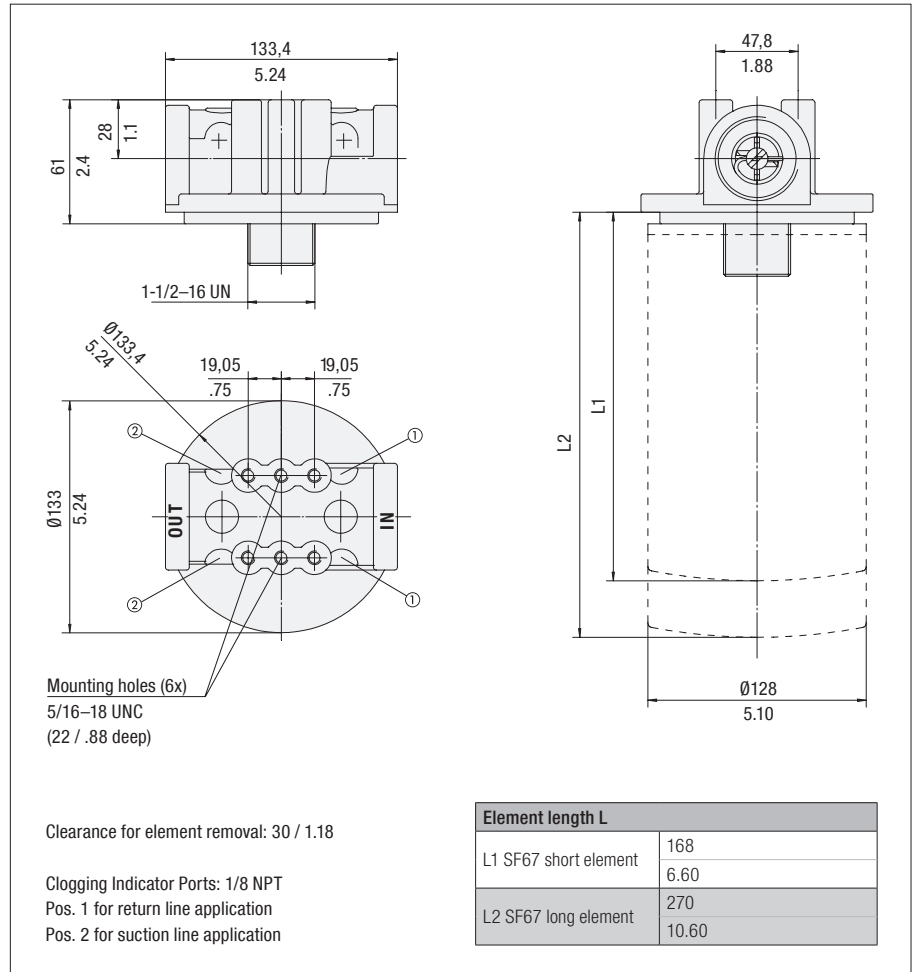

Dimensions in mm / in

Technical Data

Construction

- In-line Spin-On filter head

Material

- Aluminium

Port Connection

- NPT
- SAE O-ring thread

Flow Rate

- 300 l/min / 80 US GPM for return line application
- 113 l/min / 30 US GPM for suction line application

Operating Pressure

- Max. 14 bar / 200 PSI
- Max. 5,5 bar / 80 PSI differential pressure (for any applicaton with no bypass valve)

Temperature Range

- -32°C ... +100°C / -25°F ... +212°F

Media Compatibility

- Mineral oils, other fluids on request

Options and Accessories

Filter Elements

- For use with SF67 series elements
- For element types with seal contour type B
- For element types and flow characteristics see page C139
- The element is not part of the scope of delivery

Valve

- Bypass valve (integrated in the filter head): Optional

Clogging Indicators

- Visual clogging indicator with coloured segments
- Electrical clogging switch 0,35 ... 2,5 bar / 5 ... 35 PSI adjustable
- For clogging indicator types see page C143

Order Code

SSF - 150 - 25 - 0

1
2
3
4

1 Type

Spin-On Filter Head **SSF**

2 Connection Style

Connection	Thread	Code
NPT	1-1/2	150
SAE	1-7/8-12	180

3 Bypass Options

No bypass	00
0,2 bar / 3 PSI	03
0,35 bar / 5 PSI	05
1 bar / 15 PSI	15
1,7 bar / 25 PSI	25

4 Clogging Indicator Port Options

No clogging indicator port	0
Clogging indicator port drilled for return line application	1
Clogging indicator port drilled for suction line application	2
All clogging indicator ports drilled	4
Special	9

Note: Standard clogging indicator port is 1/8 NPT.

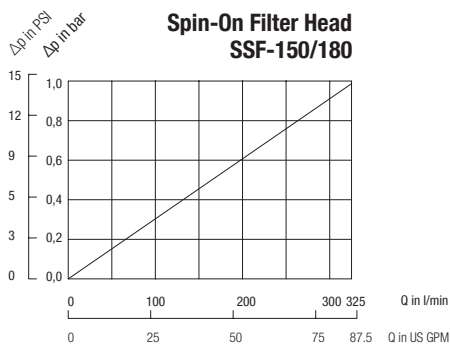

Double Spin-On Filter Heads ■ SSF-24N / 24S

Dimensions



Technical Data

Construction

- In-line Double Spin-On filter head

Material

- Aluminium

Port Connection

- NPT
- SAE flange
- SAE O-ring thread

Flow Rate

- 454 l/min / 120 US GPM for return line application
- 132 l/min / 35 US GPM for suction line application

Operating Pressure

- Max. 12 bar / 174 PSI
- Max. 5,5 bar / 80 PSI differential pressure (for any application with no bypass valve)

Temperature Range

- -30°C ... +100°C / -22°F ... +212°F

Media Compatibility

- Mineral oils, other fluids on request

Options and Accessories

Filter Elements

- For use with SF67 and SFC-57/58 series elements
- For element types with seal contour type A and B
- For element types and flow characteristics see page C139 for SF67 and page C136 for SFC-57/58
- The element is not part of the scope of delivery

Valve

- Bypass valve (integrated in the head): Optional

Clogging Indicators

- Visual clogging indicator with coloured segments
- Electrical clogging switch 0,35 ... 2,5 bar / 5 ... 35 PSI adjustable
- For clogging indicator types see page C143

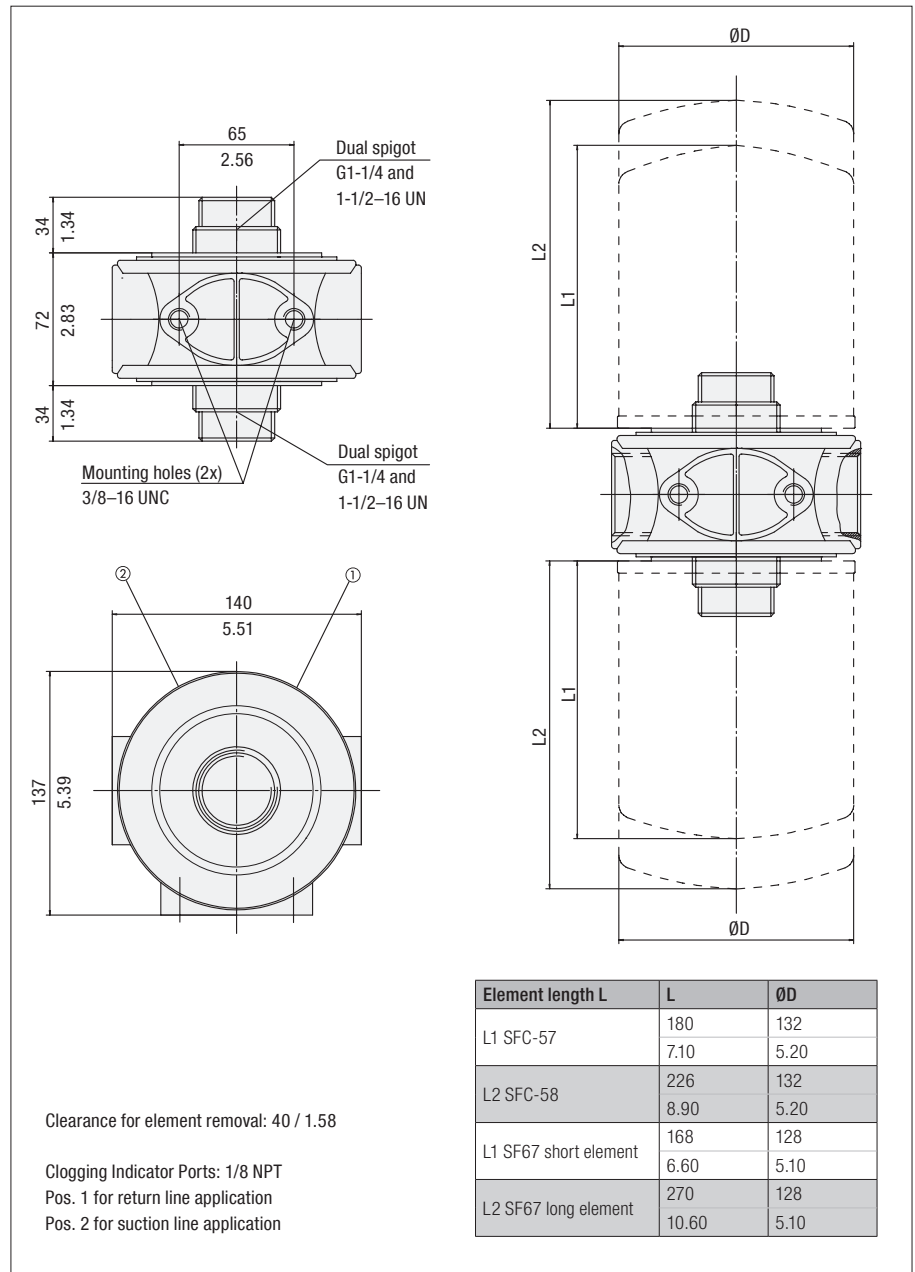
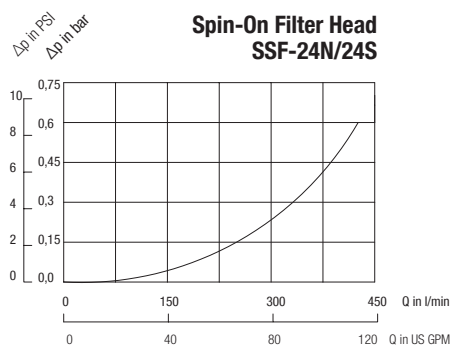

Dimensions in mm / in

Order Code

SSF - 24N - 25 - 0

① ② ③ ④

1 Type

Double Spin-On Filter Head **SSF**

2 Connection Style

Connection	Thread	Code
NPT	1-1/2	24N
SAE	1-7/8-12	24S

3 Bypass Options

No bypass	00
0,2 bar / 3 PSI	03
0,35 bar / 5 PSI	05
1 bar / 15 PSI	15
1,7 bar / 25 PSI	25

4 Clogging Indicator Port Options

No clogging indicator port	0
Clogging indicator port drilled for return line application	1
Clogging indicator port drilled for suction line application	2
All clogging indicator ports drilled	4
Special	9

Note: Standard clogging indicator port is 1/8 NPT.

Double Spin-On Filter Heads ■ SSF-25B

Dimensions

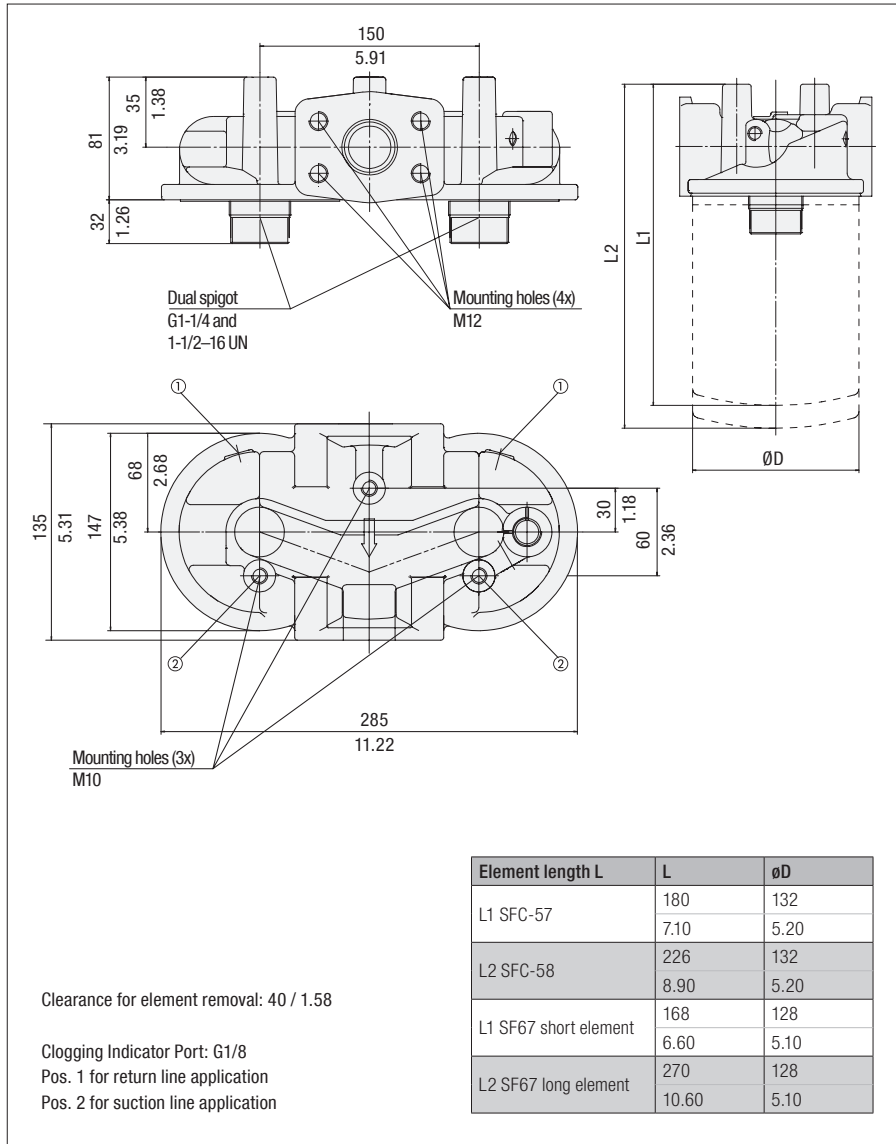

Dimensions in mm / in



Technical Data

Construction

- In-line Double Spin-On filter head

Material

- Aluminium

Port Connection

- BSP
- SAE flange

Flow Rate

- 454 l/min / 120 US GPM for return line application
- 132 l/min / 35 US GPM for suction line application

Operating Pressure

- Max. 12 bar / 174 PSI
- Max. 4 bar / 58 PSI differential pressure (for any application with no bypass valve)

Temperature Range

- -30°C ... +100°C / -22°F ... +212°F

Media Compatibility

- Mineral oils, other fluids on request

Options and Accessories
Filter Elements

- For use with SF67 and SFC-57/58 series elements
- For element types with seal contour type A and B
- For element types and flow characteristics see page C139 for SF67 and page C136 for SFC-57/58
- The element is not part of the scope of delivery

Valve

- Bypass valve (integrated in the head): Optional

Clogging Indicators

- Visual clogging indicator with coloured segments
- Electrical clogging switch 0,35 ... 2,5 bar / 5 ... 35 PSI adjustable
- For clogging indicator types see page C143

Order Code

SSF - 25B - 25 - 4

1 2 3 4

1 Type

 Double Spin-On Filter Head **SSF**
2 Connection Style

Connection	Thread	Code
BSP and SAE Flange	1-1/4 and 1-1/2 SAE Code 61 Flange	25B

3 Bypass Options

No bypass	00
0,2 bar / 3 PSI	03
1,7 bar / 25 PSI	25

Note: Other settings available on request.

4 Clogging Indicator Port Options

All clogging indicator ports drilled	4
Special	9

Note: Standard clogging indicator port is G1/8.

Spin-On Filter Head SSF-25B

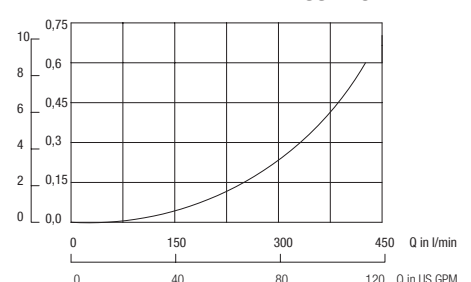

Double Spin-On Filter Heads ■ SSF-25

Dimensions



Technical Data

Construction

- In-line Double Spin-On filter head

Material

- Aluminium

Port Connection

- NPT
- SAE flange

Flow Rate

- 454 l/min / 120 US GPM for return line application
- 132 l/min / 35 US GPM for suction line application

Operating Pressure

- Max. 12 bar / 174 PSI
- Max. 5,5 bar / 80 PSI differential pressure (for any applicaton with no bypass valve)

Temperature Range

- -30°C ... +100°C / -22°F ... +212°F

Media Compatibility

- Mineral oils, other fluids on request

Options and Accessories

Filter Elements

- For use with SF67 and SFC-57/58 series elements
For element types with seal contour type A and B
For element types and flow characteristics see page C139 for SF67 and page C136 for SFC-57/58
The element is not part of the scope of delivery

Valve

- Bypass valve (integrated in the head): Optional

Clogging Indicators

- Visual clogging indicator with coloured segments
- Electrical clogging switch 0,35 ... 2,5 bar / 5 ... 35 PSI adjustable
For clogging indicator types see page C143

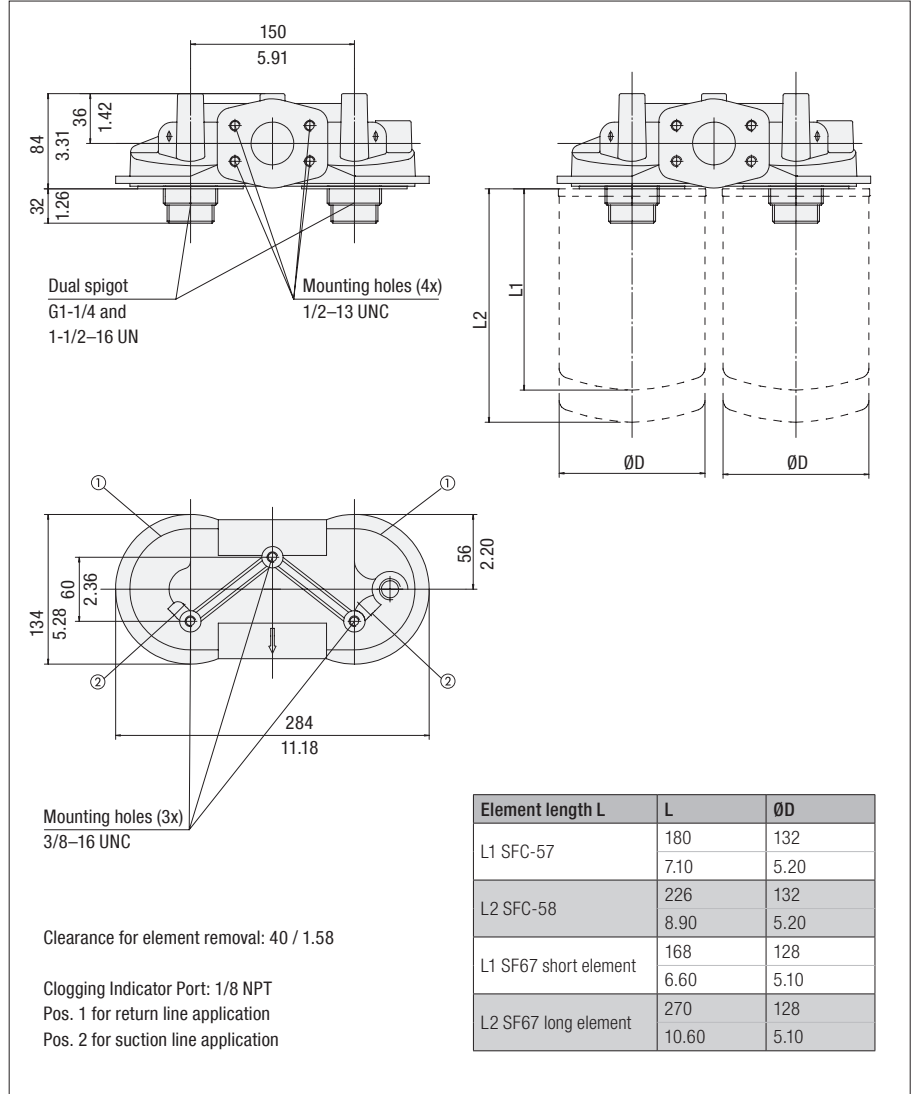

Dimensions in mm / in

Order Code

SSF - 25 - 25 - 0

- 1
- 2
- 3
- 4

1 Type

Double Spin-On Filter Head **SSF**

2 Connection Style

Connection	Thread	Code
NPT and SAE Flange	1-1/2 and 2 SAE Code 61 Flange	25

3 Bypass Options

No bypass	00
0,2 bar / 3 PSI	03
0,35 bar / 5 PSI	05
1 bar / 15 PSI	15
1,7 bar / 25 PSI	25

4 Clogging Indicator Port Options

No clogging indicator port	0
Clogging indicator port drilled for return line application	1
Clogging indicator port drilled for suction line application	2
All clogging indicator ports drilled	4
Special	9

Note: Standard clogging indicator port is 1/8 NPT.

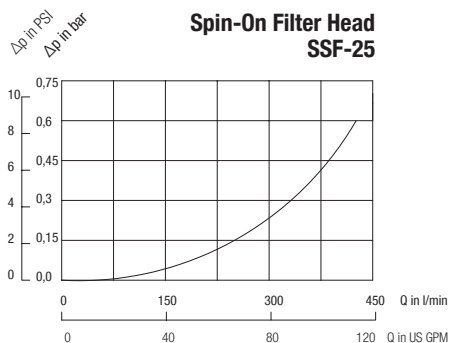

Tank Top Spin-On Filter Heads ■ SSFT-12B

Dimensions

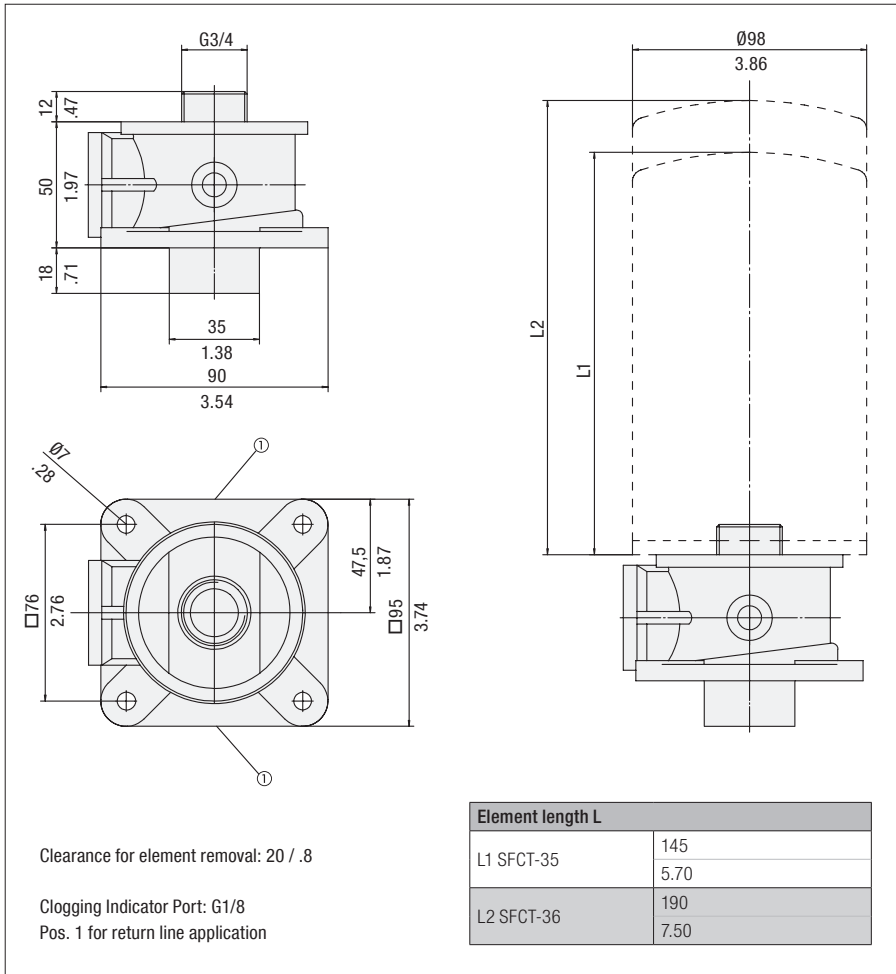

Technical Data

Construction

- Tank Top Spin-On filter head

Material

- Aluminium

Port Connection

- BSP

Flow Rate

- 75 l/min / 20 US GPM

Operating Pressure

- Max. 7 bar / 100 PSI

Temperature Range

- -30°C ... +100°C / -22°F ... +212°F

Media Compatibility

- Mineral oils, other fluids on request

Options and Accessories
Filter Elements

- For use with SFCT-35/36 series elements
For element types with seal contour type A and B
For element types and flow characteristics see page C135
The element is not part of the scope of delivery

Valve

- Bypass valve 1,7 bar / 25 PSI integrated in the filter element

Clogging Indicators

- Visual clogging indicator with coloured segments
- Electrical clogging switch 0,35 ... 2,5 bar / 5 ... 35 PSI adjustable
For clogging indicator types see page C143

Order Code

SSFT - 12B - 1

1 2 3

1 Type

 Spin-On Filter Head **SSFT**
2 Connection Style

Connection	Thread	Code
BSP	3/4	12B

3 Clogging Indicator Port Options

No clogging indicator port	0
Clogging indicator port drilled for return line application	1
Special	9

Note: Standard clogging indicator port is G1/8.

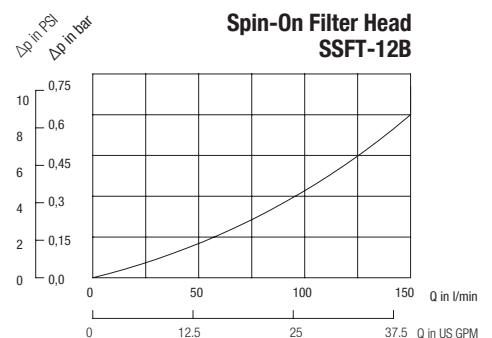

Tank Top Spin-On Filter Heads ■ SSFT-12

Dimensions

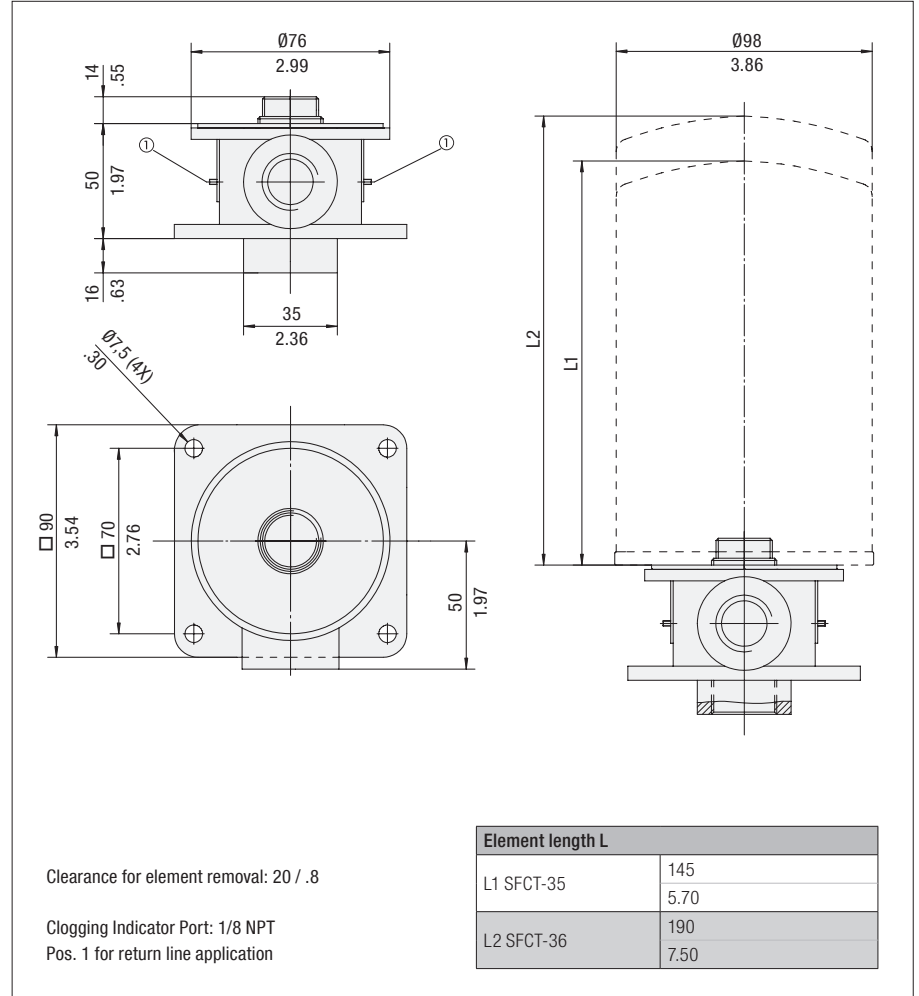

Technical Data

Construction

- Tank Top Spin-On filter head

Material

- Aluminium

Port Connection

- NPT

Flow Rate

- 75 l/min / 20 US GPM

Operating Pressure

- Max. 7 bar / 100 PSI

Temperature Range

- -30°C ... +100°C / -22°F ... +212°F

Media Compatibility

- Mineral oils, other fluids on request

Options and Accessories

Filter Elements

- For use with SFCT-35/36 series elements
- For element types with seal contour type A and B
- For element types and flow characteristics see page C135
- The element is not part of the scope of delivery

Valve

- Bypass valve 1,7 bar / 25 PSI integrated in the filter element

Clogging Indicators

- Visual clogging indicator with coloured segments
- Electrical clogging switch 0,35 ... 2,5 bar / 5 ... 35 PSI adjustable
- For clogging indicator types see page C143

Clearance for element removal: 20 / .8

Clogging Indicator Port: 1/8 NPT
Pos. 1 for return line application

Element length L	
L1 SFCT-35	145 5.70
L2 SFCT-36	190 7.50

Dimensions in mm / in

Order Code

SSFT - 12 - 1

1 2 3

1 Type

Spin-On Filter Head **SSFT**

2 Connection Style

Connection	Thread	Code
NPT	3/4	12

3 Clogging Indicator Port Options

No clogging indicator port	0
Clogging indicator port drilled for return line application	1
Special	9

Note: Standard clogging indicator port is 1/8 NPT.

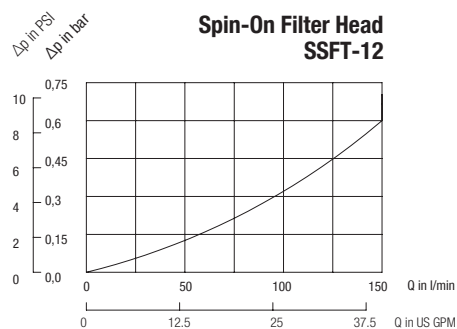

Tank Top Spin-On Filter Heads ■ SSFT-20B

Dimensions

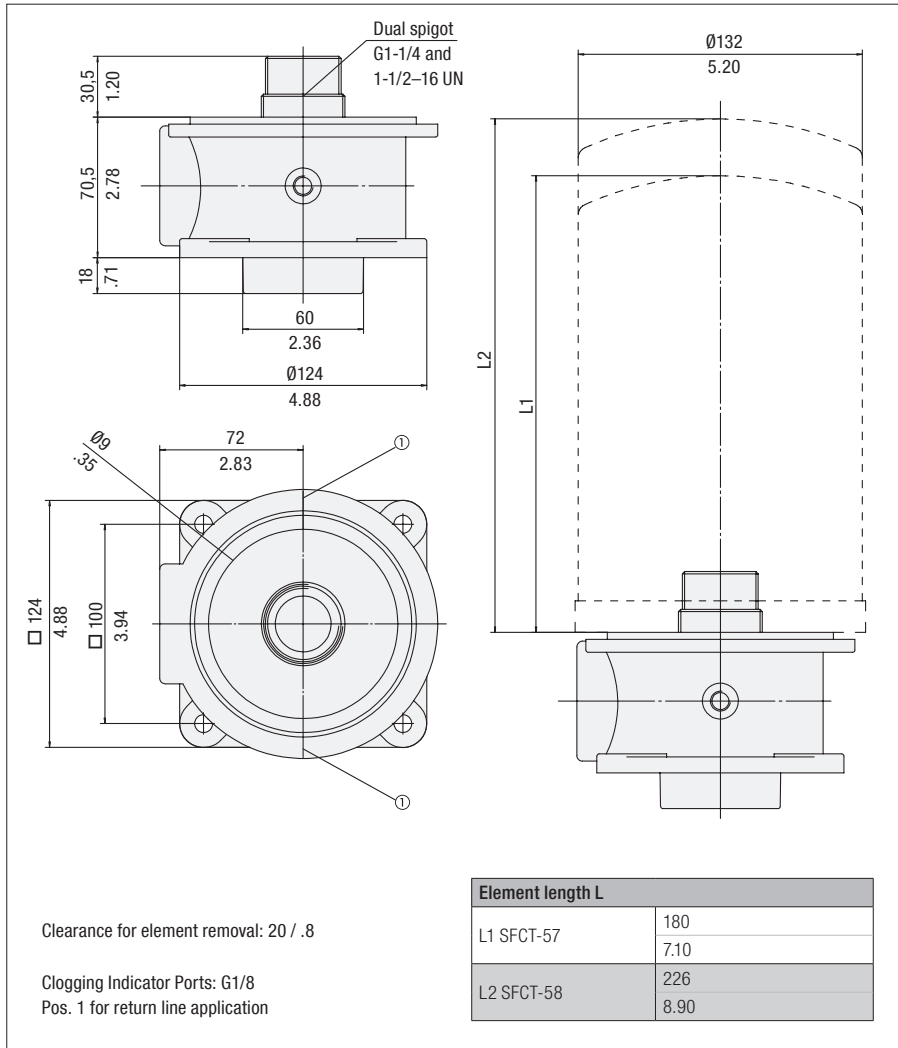

Dimensions in mm / in



Technical Data

Construction

- Tank Top Spin-On filter head

Material

- Aluminium

Port Connection

- BSP

Flow Rate

- 200 l/min / 53 US GPM

Operating Pressure

- Max. 7 bar / 100 PSI

Temperature Range

- -30°C ... +100°C / -22°F ... +212°F

Media Compatibility

- Mineral oils, other fluids on request

Options and Accessories

Filter Elements

- For use with SFCT-57/58 series elements
- For element types with seal contour type A
- For element types and flow characteristics see page C136
- The element is not part of the scope of delivery

Valve

- Bypass valve 1,7 bar / 25 PSI integrated in the filter element

Clogging Indicators

- Visual clogging indicator with coloured segments
- Electrical clogging switch 0,35 ... 2,5 bar / 5 ... 35 PSI adjustable
- For clogging indicator types see page C143

Order Code

SSFT - 20B - 1

1

2

3

1 Type

 Spin-On Filter Head **SSFT**
2 Connection Style

Connection	Thread	Code
BSP	1-1/2	20B

3 Clogging Indicator Port Options

 Clogging indicator port drilled for return line application **1**

 Special **9**

Note: Standard clogging indicator port is G1/8.

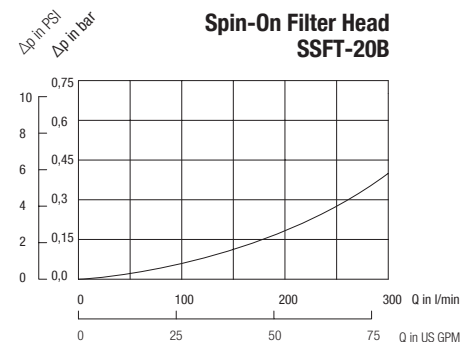
**Spin-On Filter Head
SSFT-20B**

Tank Top Spin-On Filter Heads ■ SSFT-20

Dimensions

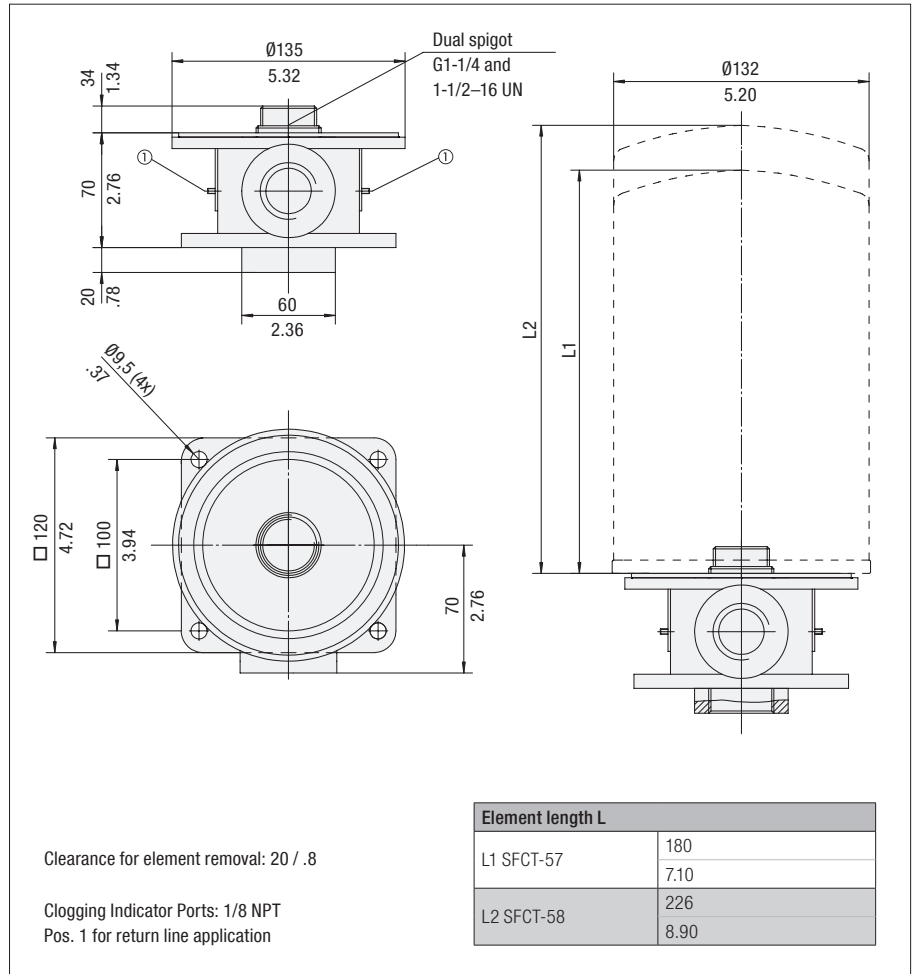

Dimensions in mm / in

Technical Data

Construction

- Tank Top Spin-On filter head

Material

- Aluminium

Port Connection

- NPT

Flow Rate

- 200 l/min / 53 US GPM

Operating Pressure

- Max. 7 bar / 100 PSI

Temperature Range

- -30°C ... +100°C / -22°F ... +212°F

Media Compatibility

- Mineral oils, other fluids on request

Options and Accessories

Filter Elements

- For use with SFCT-57/58 series elements
For element types with seal contour type A
For element types and flow characteristics see page C136
The element is not part of the scope of delivery

Valve

- Bypass valve 1,7 bar / 25 PSI integrated in the filter element

Clogging Indicators

- Visual clogging indicator with coloured segments
- Electrical clogging switch 0,35 ... 2,5 bar / 5 ... 35 PSI adjustable
For clogging indicator types see page C143

Order Code



1 Type

Spin-On Filter Head **SSFT**

2 Connection Style

Connection	Thread	Code
NPT	1-1/2	20

3 Clogging Indicator Port Options

No clogging indicator port	0
Clogging indicator port drilled for return line application	1
Special	9

Note: Standard clogging indicator port is 1/8 NPT.

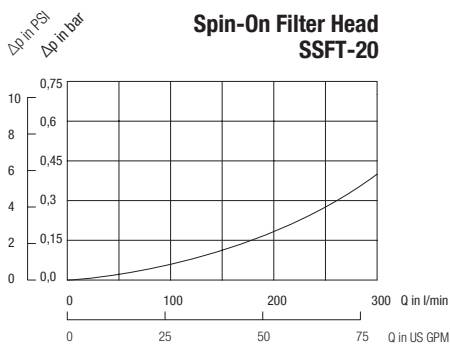

Spin-On Elements ▪ Type SFC-35 / 36 and SFCT-35 / 36

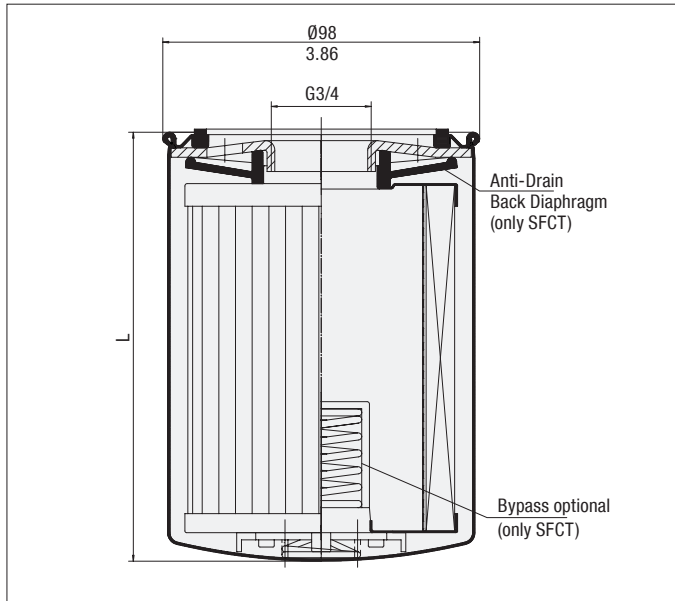

Dimensions in mm / in

Product Description

STAUFF SFC-35/36 series Spin-On Elements are used with the STAUFF SSF-12 Spin-On Filters with G3/4 threaded ports.

STAUFF SFCT-35/36 series Spin-On Elements have an internal 1,7 bar / 25 PSI bypass and anti-drain back diaphragm for use with STAUFF SSFT-12 Tank Top Spin-On Filters.

Technical Data
Connection Thread

- G3/4

Seal Contour

- Type A (see page C119)

Sealing Material

- NBR (Buna-N®)

Operating Pressure

- SFC: Max. 12 bar / 174 PSI
- SFCT: Max. 7 bar / 100 PSI

Differential Pressure

- SFC: Max. 4 bar / 58 PSI
- SFCT: Max. 3 bar / 43,5 PSI
(for any application with no bypass valve)

Burst Pressure

- SFC: Max. 25 bar / 363 PSI
- SFCT: Max. 21 bar / 305PSI

Bypass Pressure

- 1,7 bar / 25 PSI (only SFCT-series)

Temperature Range

- -32°C ...+100°C / -25°F ... +212°F

Media Compatibility

- Mineral oils, other fluids on request

Dimensions

Order Code	Filter Paper				Inorganic Glass Fibre					
	Element without bypass valve	SFC-3510E	SFC-3610E	SFC-3525E	SFC-3625E	SFC-3503AE	SFC-3603AE	SFC-3510AE	SFC-3610AE	SFC-3525AE
Element with bypass valve	SFCT-3510E	SFCT-3610E	SFCT-3525E	SFCT-3625E	SFCT-3503AE	SFCT-3603AE	SFCT-3510AE	SFCT-3610AE	SFCT-3525AE	SFCT-3625AE
Length L (mm/in)	145 5.7	190 7.5	145 5.7	190 7.5	145 5.7	190 7.5	145 5.7	190 7.5	145 5.7	190 7.5
β-Ratio	$\beta_{10} \geq 2$	$\beta_{10} \geq 2$	$\beta_{25} \geq 2$	$\beta_{25} \geq 2$	$\beta_3 \geq 200$	$\beta_3 \geq 200$	$\beta_{10} \geq 200$	$\beta_{10} \geq 200$	$\beta_{25} \geq 200$	$\beta_{25} \geq 200$
Filter Area (cm ² /in ²)	3305 510	4745 735	3305 510	4745 735	2140 330	3630 560	2140 330	3630 560	2140 330	3630 560
Carton Quantity	1	1	1	1	1	1	1	1	1	1
Carton Weight (kg/lbs)	0,9 2	1,3 2,6	0,9 2	1,3 2,6	0,9 2	1,3 2,6	0,9 2	1,3 2,6	0,9 2	1,3 2,6

Order Code	Wire Mesh		Brass Mesh	
	Element without bypass valve	SFC-3560E	SFC-3660E	SFC-35125E
Element with bypass valve	SFCT-3560E	SFCT-3660E	SFCT-35125E	SFCT-36125E
Length L (mm/in)	145 5.7	190 7.5	145 5.7	190 7.5
β-Ratio	n/a	n/a	n/a	n/a
Filter Area (cm ² /in ²)	980 150	1390 215	980 150	1390 215
Carton Quantity	1	1	1	1
Carton Weight (kg/lbs)	0,9 2	1,3 2,6	0,9 2	1,3 2,6

Spin-On Elements ▪ Type SFC-57 / 58 and SFCT-57 / 58

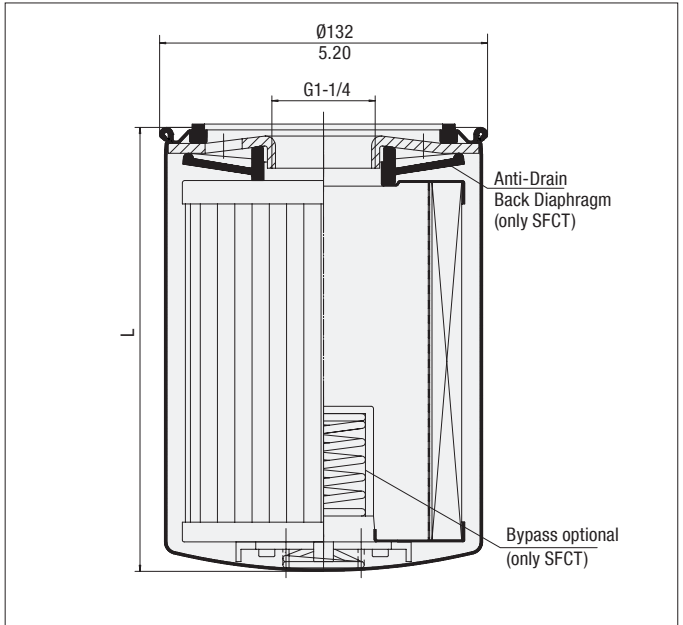

Dimensions in mm / in

Product Description

STAUFF Spin-On Filter Elements of the SFC-/SFCT-57/58 series are used with the STAUFF SSF-20/24/25/100/120/130 and 160 series Spin-On Filters with G1-1/4 threaded ports.

STAUFF SFCT-57/58 series Spin-On Elements have an internal, 1,7 bar / 25 PSI bypass and anti-drain back diaphragm for use with STAUFF SSFT-20 Tank Top Spin-On Filters.

Technical Data

Connection Thread

- G1-1/4

Operating Pressure

- SFC: Max. 12 bar / 174 PSI
- SFCT: Max. 7 bar / 100 PSI

Burst Pressure

- SFC: Max. 25 bar / 363 PSI
- SFCT: Max. 21 bar / 305PSI

Temperature Range

- -32°C ...+100°C / -25°F ... +212°F

Seal Contour

- Type A (see page C119)

Differential Pressure

- SFC: Max. 4 bar / 58 PSI
- SFCT: Max. 3 bar / 43,5PSI

Bypass Pressure

- 1,7 bar / 25 PSI
- (only SFCT-series)

Media Compatibility

- Mineral oils, other fluids on request

Sealing Material

- NBR (Buna-N®)

(for any application with no bypass valve)

Dimensions

Order Code	Filter Paper				Inorganic Glass Fibre					
	Element without bypass valve	SFC-5710E	SFC-5810E	SFC-5725E	SFC-5825E	SFC-5703AE	SFC-5803AE	SFC-5710AE	SFC-5810AE	SFC-5725AE
Element with bypass valve	SFCT-5710E	SFCT-5810E	SFCT-5725E	SFCT-5825E	SFCT-5703AE	SFCT-5803AE	SFCT-5710AE	SFCT-5810AE	SFCT-5725AE	SFCT-5825AE
Length L (mm/in)	180 7.1	226 8.9	180 7.1	226 8.9	180 7.1	226 8.9	180 7.1	226 8.9	180 7.1	226 8.9
β-Ratio	β ₁₀ ≥ 2	β ₁₀ ≥ 2	β ₂₅ ≥ 2	β ₂₅ ≥ 2	β ₃ ≥ 200	β ₃ ≥ 200	β ₁₀ ≥ 200	β ₁₀ ≥ 200	β ₂₅ ≥ 200	β ₂₅ ≥ 200
Filter Area (cm ² /in ²)	5560 860	7360 1140	5560 860	7360 1140	4450 700	5890 910	4450 700	5890 910	4450 700	5890 910
Carton Quantity	1	1	1	1	1	1	1	1	1	1
Carton Weight (kg/lbs)	1,4 3	1,85 4	1,4 3	1,85 4	1,4 3	1,85 4	1,4 3	1,85 4	1,4 3	1,85 4

Order Code	Wire Mesh		Brass Mesh	
	Element without bypass valve	SFC-5760E	SFC-5860E	SFC-57125E
Element with bypass valve	SFCT-5760E	SFCT-5860E	SFCT-57125E	SFCT-58125E
Length L (mm/in)	180 7.1	226 8.9	180 7.1	226 8.9
β-Ratio	n/a	n/a	n/a	n/a
Filter Area (cm ² /in ²)	1940 300	2570 400	1940 300	2570 400
Carton Quantity	1	1	1	1
Carton Weight (kg/lbs)	0,9 2	1,3 2,6	0,9 2	1,3 2,6

Spin-On Elements ▪ Type SF63

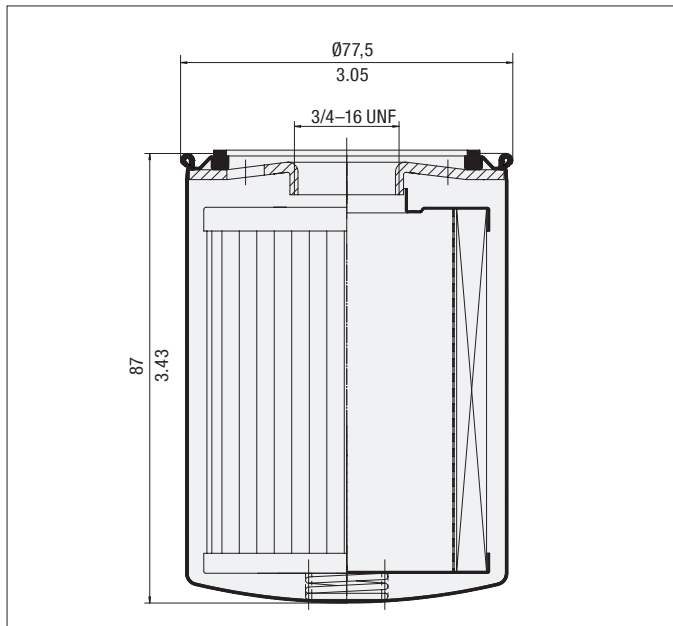

Dimensions in mm / in

Product Description

STAUFF SF63-series Spin-On Elements are used with the STAUFF SLF Spin-On Filters.

Technical Data
Connection Thread

- 3/4-16 UNF

Seal Contour

- Type A (see page C119)

Sealing Material

- NBR (Buna-N®)

Operating Pressure

- Max. 14 bar / 200 PSI

Differential Pressure

- Max. 5,5 bar / 80 PSI
(for any application with no bypass valve)

Burst Pressure

- Max. 20 bar / 290 PSI

Bypass Pressure

- SF6310-18 1,24 bar / 18 PSI
- SF6325-10 0,70 bar / 10 PSI

Temperature Range

- -32°C ... +100°C / -25°F ... +212°F

Media Compatibility

- Mineral oils, other fluids on request

Dimensions

Order Code	Filter Paper	
	SF6310-18	SF6325-10
β-Ratio	$\beta_{10} \geq 2$	$\beta_{25} \geq 2$
Filter Area (cm²/in²)	825 125	825 125
Dirt Holding Capacity (g)	6	6
Carton Quantity	12	12
Carton Weight (kg/lbs)	3,6 8	3,6 8

Spin-On Elements ■ Type SF65



Product Description

STAUFF SF65-series Spin-On Elements are used with the STAUFF SAF series Spin-On Filters.

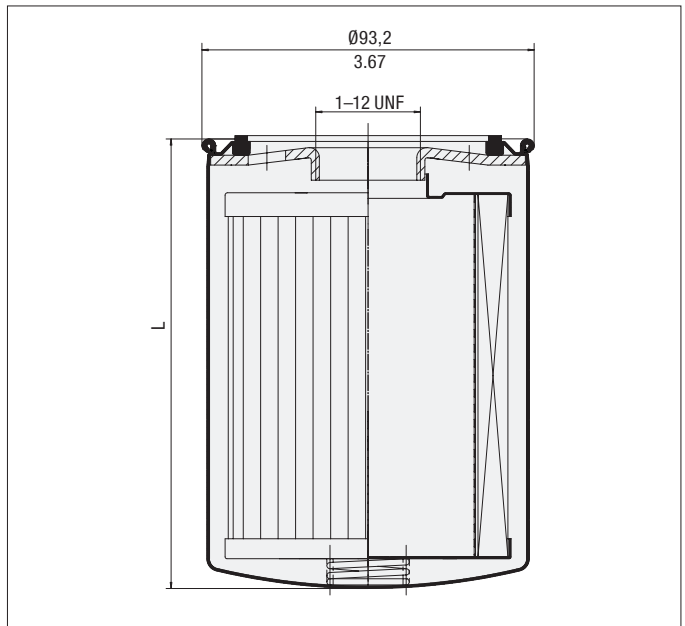

Dimensions in mm / in

Technical Data

Connection Thread

- 1-12 UNF

Sealing Material

- NBR (Buna-N®)

Differential Pressure

- Max. 5,5 bar / 80 PSI
(for any application with no bypass valve)

Temperature Range

- -32°C ... +100°C / -25°F ... +212°F

Seal Contour

- Type A (see page C119)

Operating Pressure

- Max. 14 bar / 200 PSI







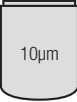

Burst Pressure

- Max. 20 bar / 290 PSI

Media Compatibility

- Mineral oils, other fluids on request

Dimensions

Order Code	Filter Paper				Inorganic Glass Fibre			Water Absorbing
	SF6520	SF6521	SF6510	SF6511	SF6549	SF6505	SF6504	SF6520-W
								
Length L (mm/in)	147 5.76	204 8.00	147 5.76	204 8.00	147 5.76	147 5.76	147 5.76	133 5.25
β-Ratio	$\beta_{10} \geq 2$	$\beta_{10} \geq 2$	$\beta_{25} \geq 2$	$\beta_{25} \geq 2$	$\beta_3 \geq 200$	$\beta_{12} \geq 200$	$\beta_{25} \geq 200$	$\beta_{10} \geq 2$
Filter Area (cm ² /in ²)	2302 355	3881 600	2212 340	3388 525	2519 390	2405 370	2405 370	1225 200
Dirt Holding Capacity ACFTD (g)	14.4	22	20.4	31.2	19	11	26	Water holding capacity 162 ml 5.5 oz
Carton Quantity	12	12	12	12	12	12	12	12
Carton Weight (kg/lbs)	6,3 13.9	8,4 18.5	6,4 14.2	8,8 19.4	8,6 19	8,6 19	8,6 19	8,6 19

Spin-On Elements ▪ Type SF67

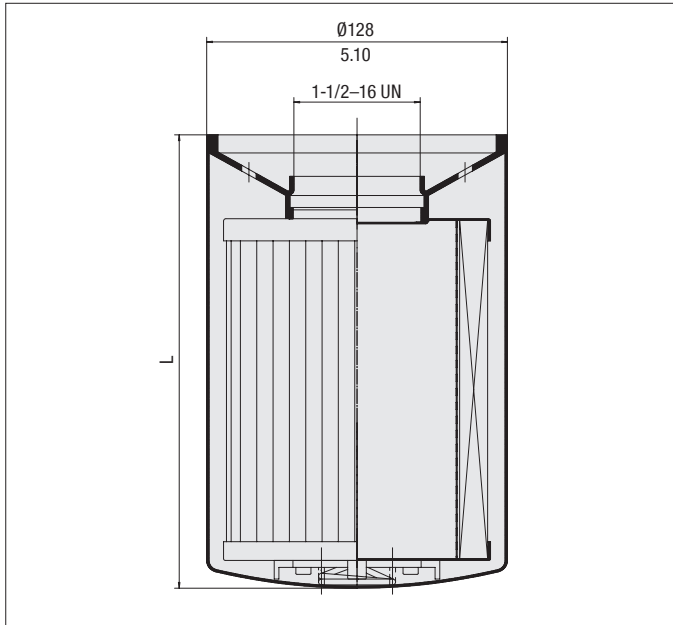

Dimensions in mm / in



Product Description

STAUFF SF67-series Spin-On Elements are used with the STAUFF SSF20/24/25/100/120/130/160/150 and 180 Spin-On Filters.

Technical Data

Connection Thread

- 1-1/2-16 UN

Sealing Material

- NBR (Buna-N®)

Differential Pressure

- Max. 5,5 bar / 80 PSI
(for any application with no bypass valve)

Temperature Range

- -32°C ... +100°C / -25°F ... +212°F

Seal Contour

- Type B (see page C119)

Operating Pressure

- Max. 14 bar / 200 PSI

Burst Pressure

- Max. 20 bar / 290 PSI

Media Compatibility

- Mineral oils, other fluids on request

Dimensions

Order Code	Inorganic Glass Fibre								
	SF6702-MG	SF6703-MG	SF6704-MG	SF6706-MG	SF6707-MG	SF6730-MG	SF6731-MG	SF6728-MG	SF6726-MG
Length L (mm/in)	270 10.6	168 6.6	270 10.6	168 6.6	270 10.6	168 6.6	270 10.6	168 6.6	270 10.6
β-Ratio	$\beta_1 \geq 200$	$\beta_3 \geq 200$	$\beta_3 \geq 200$	$\beta_6 \geq 200$	$\beta_6 \geq 200$	$\beta_{12} \geq 200$	$\beta_{12} \geq 200$	$\beta_{25} \geq 200$	$\beta_{25} \geq 200$
Filter Area (cm ² /in ²)	8167 1265	4051 625	8167 1265	4051 625	7200 1116	4051 625	7522 1165	4051 625	8167 1265
Dirt Holding Capacity ACFTD (g)	30	31	47	35	54	38	59	50	76
Carton Quantity	6	6	6	6	6	6	6	6	6
Carton Weight (kg/lbs)	11,8 26.1	8,2 18	11,8 26.1	8,2 18	11,8 26.1	8,2 18	11,8 26.1	8,2 18	11,8 26.1

Order Code	Filter Paper				Stainless Wire Mesh		Water Absorbing
	SF6720	SF6721	SF6710	SF6711	SF6790	SF6791	SF6721-W
Length L (mm/in)	168 6.6	270 10.6	168 6.6	270 10.6	168 6.6	270 10.6	270 10.6
β-Ratio	$\beta_{10} \geq 2$	$\beta_{10} \geq 2$	$\beta_{25} \geq 2$	$\beta_{25} \geq 2$	n/a	n/a	$\beta_{10} \geq 2$
Filter Area (cm ² /in ²)	3677 570	6813 1055	3677 570	6813 1055	1290 200	2032 315	4440 690
Dirt Holding Capacity ACFTD (g)	34	62	34	62	n/a	n/a	Water holding capacity 444 ml / 15 oz
Carton Quantity	6	6	6	6	6	6	6
Carton Weight (kg/lbs)	6,6 14.6	7,9 17.5	6,7 14.9	9,3 20.6	8,2 18	11,8 26.1	11,8 26.1

Spin-On Elements ■ Type SFC/SFCT-35/36, SFC/SFCT-57/58 and SF63

The following characteristics are valid for mineral oils with a density of 0,85 kg/dm³ and the kinematic viscosity of 30 mm²/s (30 cSt). The characteristics have been determined in accordance to ISO 3968. SFC-35/36 series Spin-On Elements are used with STAUFF SSF-12 Spin-On Filters, SFCT-35/36 series Spin-On Elements are used with STAUFF SSFT-12 Spin-On Filters, SFC-57/58 series Spin-On Elements are used with STAUFF SSF-20/24/25/100/120/130/160 Spin-On Filters, SFCT-57/58 series Spin-On Elements are used with STAUFF SSFT-20 Spin-On Filters and SF63 series Spin-On Elements are used with STAUFF SLF-02/03/04 Spin-On Filters.

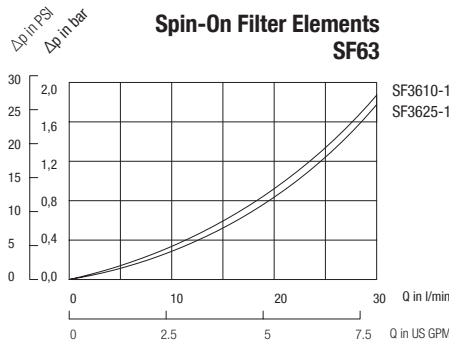
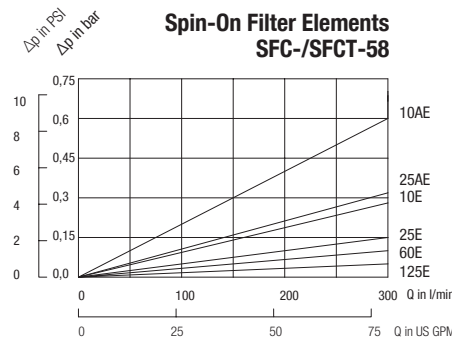
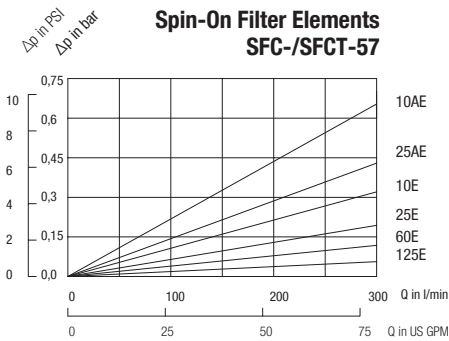
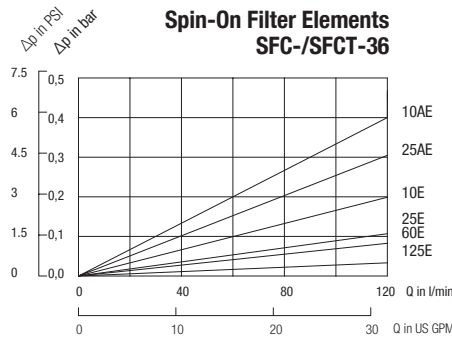
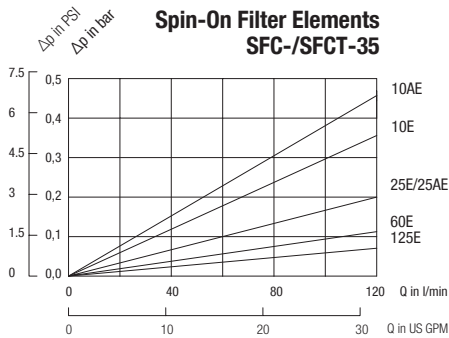

Spin-On Elements ■ Type SF65

The following characteristics are valid for mineral oils with a density of 0,85 kg/dm³ and the kinematic viscosity of 30 mm²/s (30 cSt). The characteristics have been determined in accordance to ISO 3968. SF65 Spin-On Elements are used with the STAUFF SAF-05/06/07/10/11/13 Spin-On Filters.

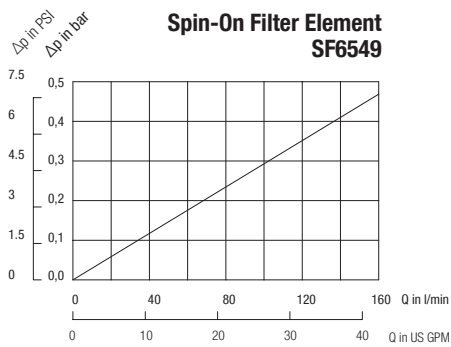
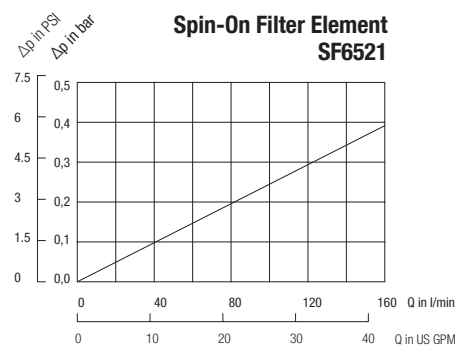
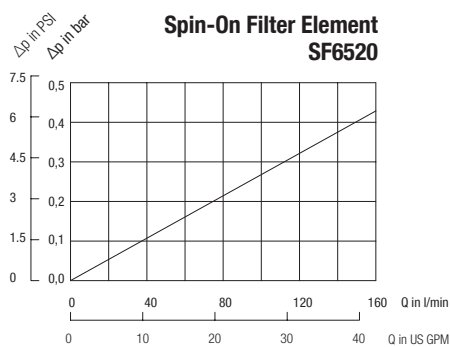
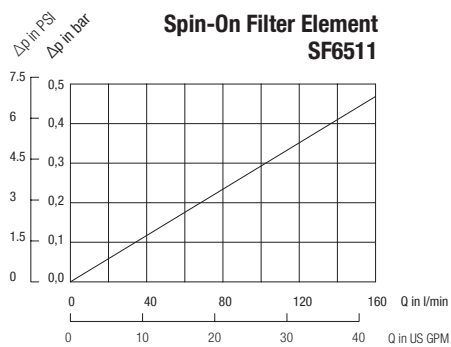
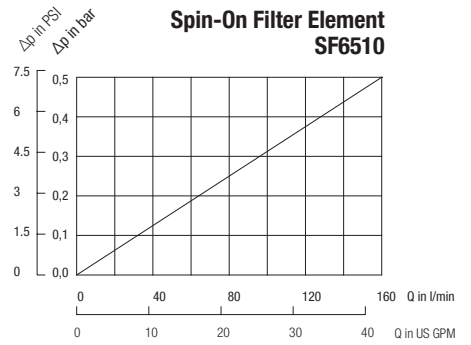
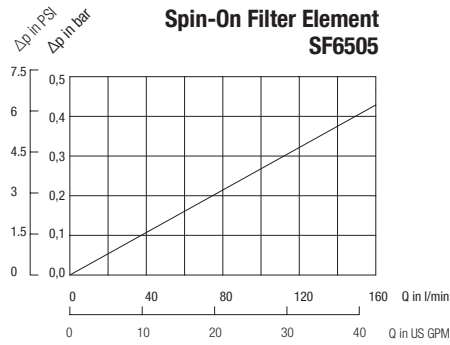
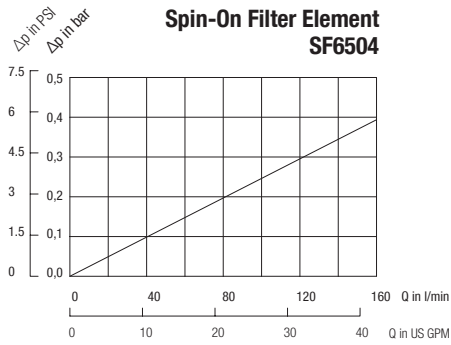

Spin-On Elements - Type SF67

The following characteristics are valid for mineral oils with a density of 0,85 kg/dm³ and the kinematic viscosity of 30 mm²/s (30 cSt). The characteristics have been determined in accordance to ISO 3968. SF67 Spin-On Elements are used with the STAUFF SSF-20/24/25/100/120/130/160/150/180 Spin-On Filters.

Spin-On Filter Element SF6702-MG

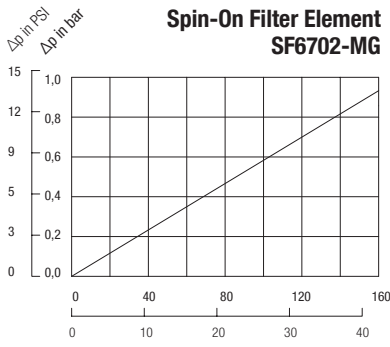

Spin-On Filter Element SF6703-MG

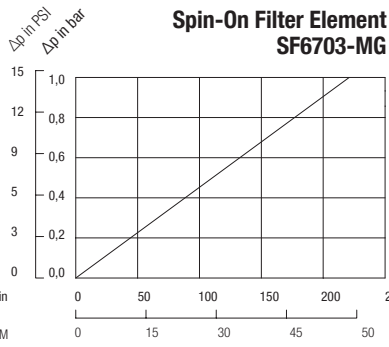

Spin-On Filter Element SF6704-MG

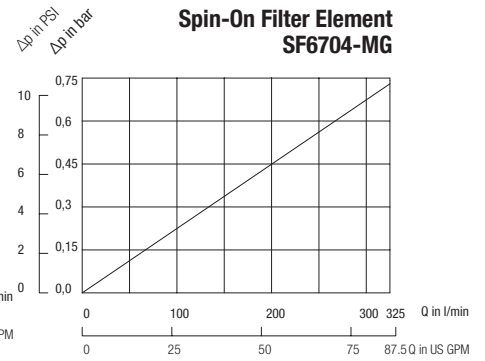

Spin-On Filter Element SF6706-MG

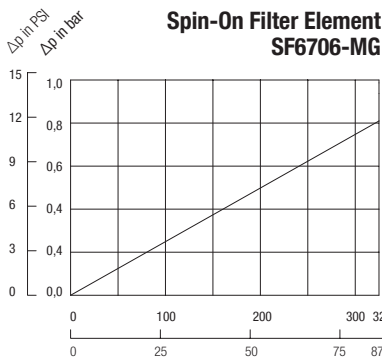

Spin-On Filter Element SF6707-MG

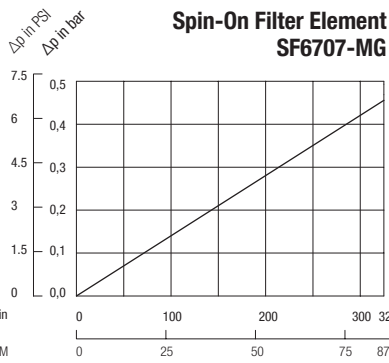

Spin-On Filter Element SF6710

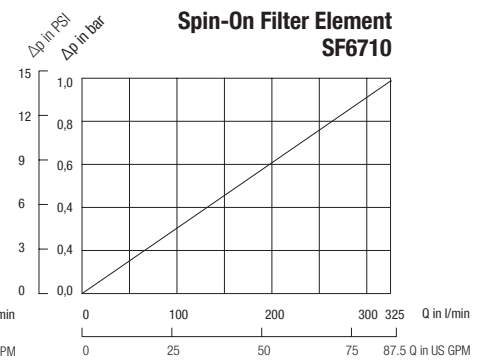

Spin-On Filter Element SF6711

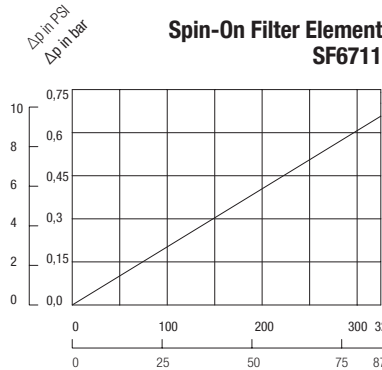

Spin-On Filter Element SF6720

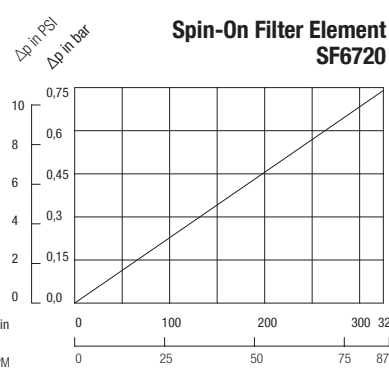

Spin-On Filter Element SF6721

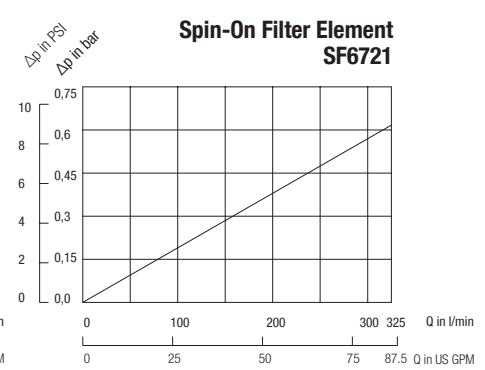

Spin-On Filter Element SF6726 -MG

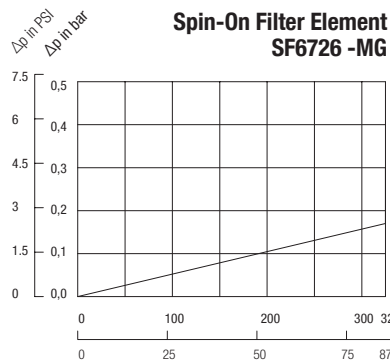

Spin-On Filter Element SF6728-MG

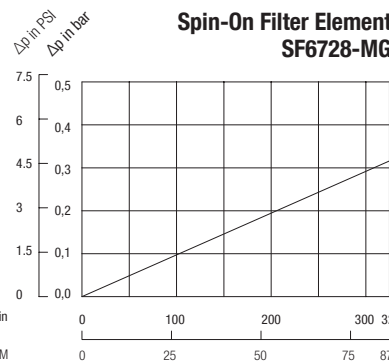

Spin-On Filter Element SF6730-MG

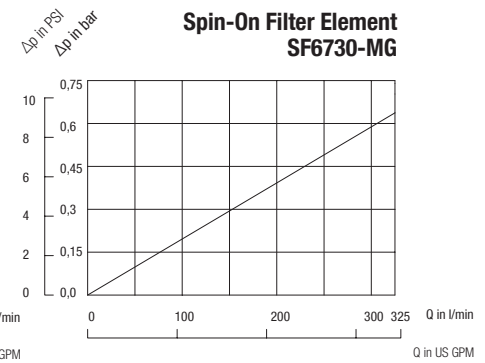

Spin-On Filter Element SF6731-MG

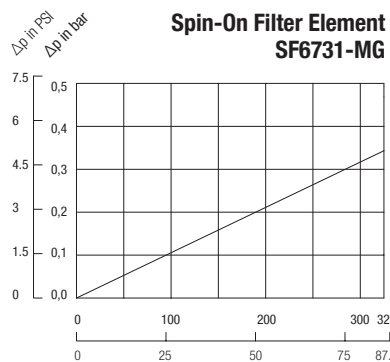

Spin-On Filter Element SF6790/91

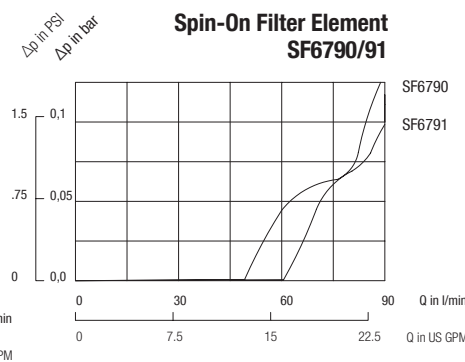

Clogging Indicators

Visual Clogging Indicators



SIS



GV-10

Visual Vacuum Clogging Indicators (for Spin-On Filter in suction line applications)

	Type	Thread Connection G	Unit of scale	Range of scale	Coloured Segments			Valve setting Spin-On Filter
					Green	Yellow	Red	
BSP	SIS	1/8	cm Hg	-76 ... 0	-13 ... 0	-18 ... -13	-76 ... -18	0,2 bar/ 3 PSI
	GV-5	1/8	in Hg	-30 ... 0	-4 ... 0	-6 ... -4	-30 ... -6	0,2 bar/ 3 PSI
NPT	GV-10	1/8	in Hg	-30 ... 0	-9 ... 0	-11 ... -9	-30 ... -11	0,35 bar/ 5 PSI



SIM-04



CI-12

Visual Pressure Clogging Indicators (for Spin-On Filter in return line applications)

	Type	Thread Connection G	Unit of scale	Range of scale	Coloured Segments			Valve setting Spin-On Filter
					Green	Yellow	Red	
BSP	SIM-02	1/8	bar	0 ... 2,5	0 ... 1,2	1,2 ... 1,5	1,5 ... 2,5	1,7 bar / 25 PSI
	SIM-04	1/8	bar	0 ... 4	0 ... 2,5	2,5 ... 3	3 ... 4	1,7 bar / 25 PSI
	SIM-12	1/8	bar	0 ... 12	without coloured segments			1,7 bar / 25 PSI
NPT	CI-12	1/8	PSI	0 ... 100	0 ... 13	13 ... 15	15 ... 100	1 bar / 15 PSI
	CI-20	1/8	PSI	0 ... 100	0 ... 21	21 ... 25	25 ... 100	1,7 bar / 25 PSI

Electrical Clogging Indicators



SIE-NO/NC



EPS/EVS

Electrical Clogging Indicators (for Spin-On Filter in return line or suction line applications)

	Type	Thread Connection G	Unit of scale	Adjustable range / Actuating pressure	Max. over pressure	Spin-On filter application	Valve setting Spin-On Filter
BSP	SIE-NO	1/8	bar	1,3 (normally open)	80 bar / 1160 PSI	Return line application	1,7 bar / 25 PSI
	SIE-NC	1/8	bar	1,3 (normally closed)	80 bar / 1160 PSI	Return line application	1,7 bar / 25 PSI
	EPS-1B	1/8	bar	0,35 ... 2,5	25 bar / 362 PSI	Return line application	1,7 bar / 25 PSI
	EVS-1B	1/8	mbar	-1000 ... -150	25 bar / 362 PSI	Suction line application	0,2 bar / 3 PSI
NPT	EPS-1	1/8	PSI	5 ... 35	24 bar / 350 PSI	Return line application	1,7 bar / 25 PSI
	EVS-1	1/8	in Hg	-30 ... -5	24 bar / 350 PSI	Suction line application	0,2 bar / 3 PSI

Technical Data SIE / EPS / EVS

	Type EPS-1 / 1B	Type EVS-1 / 1B
Electrical data	6 Amp 125/250 V AC	
Protection	DIN 43650 IP65	
Temperature Range	-5°C ... +90°C / +23°F ... +194°F (ambient and media)	
Diaphragm Material	NBR (Buna-N®)	NBR (Buna-N®)
Housing Material	Brass	Steel
Adjustable Range	0,35 bar ... 2,0 bar / 5 ... 30 PSI	150 ... 1000 mbar / 5 ... 30 in Hg
Dead Band	20% F.S.	25% F.S.
Weight	0,1 kg / .22 lbs	0,1 kg / .22 lbs
Repeatability	± 2%	
Hirschmann Connector With Strain Relief		

	Type SIE (electrical switch)
Electrical data	48V
Protection	DIN 43650 IP54
Temperature Range	-5 °C ... +60 °C / 23 °F ... +140 °F (ambient and media)
Diaphragm Material	NBR (Buna-N®)
Housing Material	Brass
Actuating Pressure	1,3 bar / 19 PSI
Max. current (res.)	0,5 A
Max. current (ind.)	0,2 A
Available as "normally open" (closes contact at actuating pressure) and as "normally closed" (opens contact at actuating pressure)	

Dimensions

Type SIM / SIS

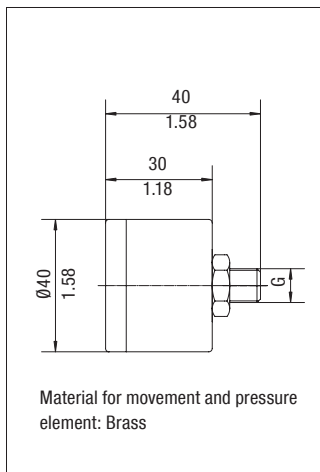

Type GV / CI

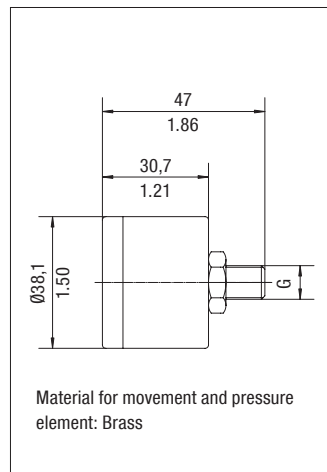

Type SIE

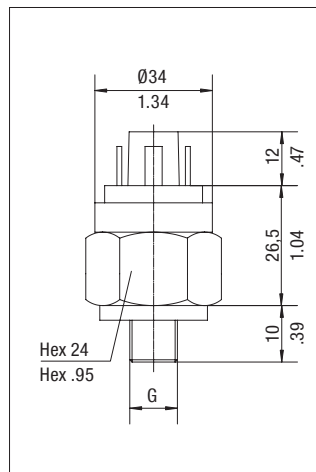

Type EPS / EVS

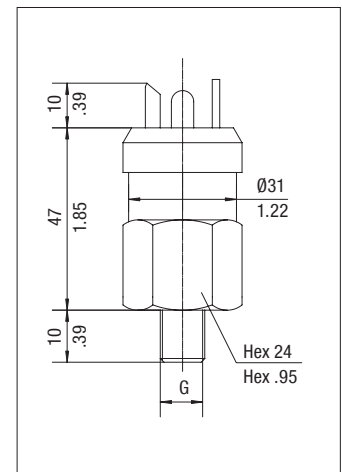

Dimensions in mm/in

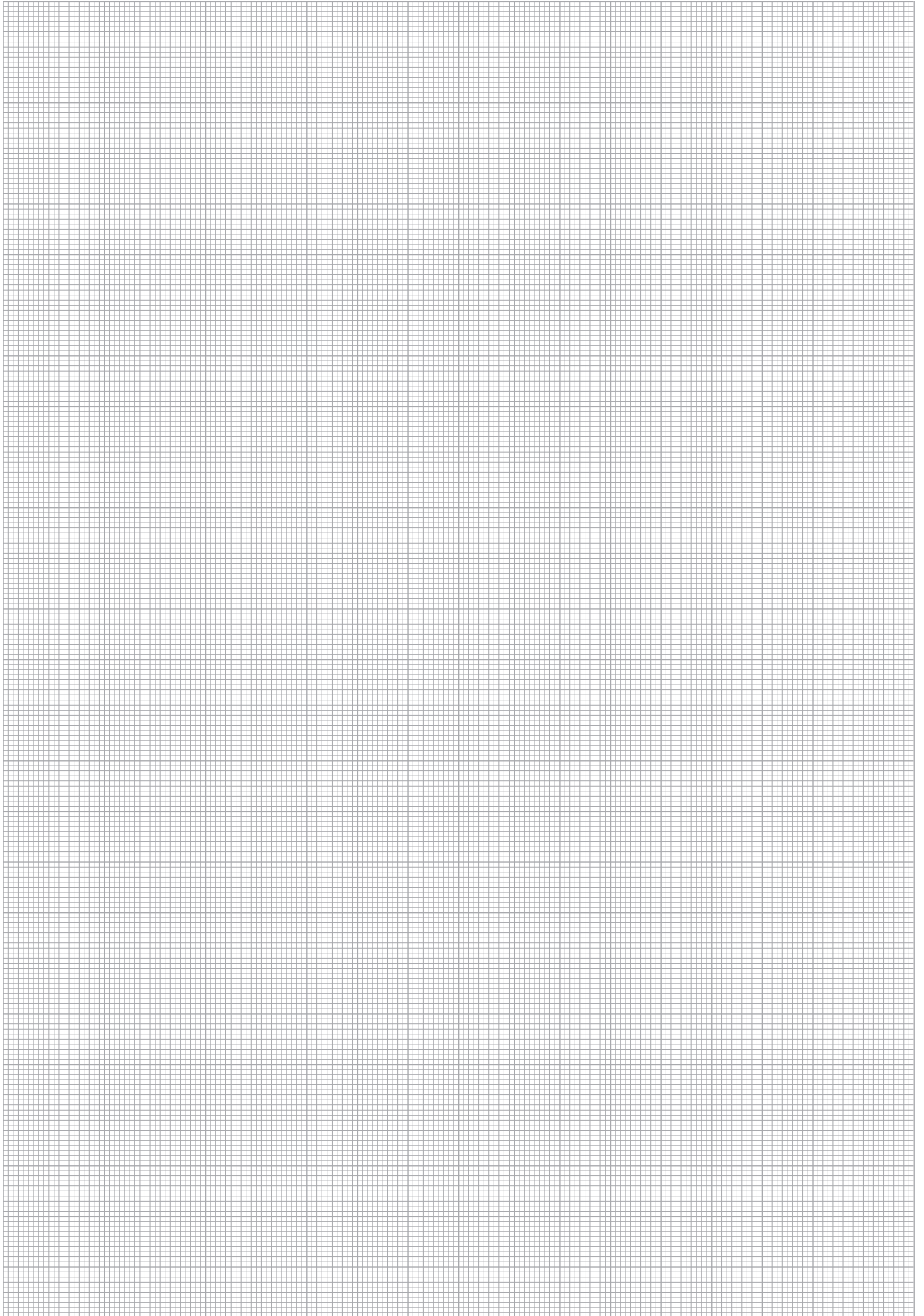

Product Description

STAUFF Off-Line and Bypass Filter Systems are designed to keep hydraulic and lubrication systems free of particles and water contamination. STAUFF OLS and BPS Units utilize the STAUFF Systems concept for the removal of contamination from hydraulic and lubrication systems. Desiccant Air Breathers, which clean and dry the air entering the reservoir, are also part of this contamination removal system.

STAUFF Systems will provide optimal system cleanliness for today's sophisticated hydraulic and lubrication systems.



Technical Data

Construction

- OLS: Off-Line Filter System with integrated motor / pump unit
- BPS: Bypass Filter System

Materials

- Housing: Anodized Aluminium
- Sealings: NBR (Buna-N®)

Port Connection

- OLS: G3/8, G1/2, G3/4 and 18 L
- BSP: G1/4 and G1/2

Differential Pressure

- Max. 6,2 bar / 90 PSI

Nominal Flow

- 2,1 ... 17 l/min / .55 ... 4.5 US GPM

Max. System Volume

- Up to 10800 l / 2853 gal

Temperature Range

- Max. +80 °C / +176 °F media temperature

Media Compatibility

- Mineral and lubrication oils, other fluids on request

Options and Accessories

Valve

- Bypass valve: Setting 6,2 bar / 90 PSI integrated in filter head

Clogging Indicator

- Visual clogging indicator

Motor Types (only OLS)

- Several motor types available
for more information please have a look at page C152

The STAUFF System



Filter Element SRM-30

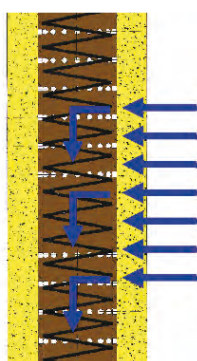

Filter Element Design



Air Conditioners SDB / SVDB

System Contamination

In today's hydraulic market it is an accepted fact that contamination causes 70 % of all mechanical failures. This contamination results from the presence of solid particles such as metal, sand and rubber.

Changes in temperature cause water vapour to condense, resulting in unwanted water in the oil, the presence of this water accelerates the deterioration of the oil.

Mainstream filters are incapable of removing particles, smaller than 2 micron (better known as silt). Fluctuations in pressure and flow result in changing conditions preventing these filters from carrying out fine filtration; most of the silt remains in the system affecting the chemical composition of the oil.

All these problems lead to reduced oil life and increased component wear, maintenance costs and machine down time.

Removing silt and preventing the formation of free water will combat these problems.

Micro Filtration

At the heart of the STAUFF Off-Line and Bypass Filter Unit is the unique microfilter element. This filter is designed with a radial flow path.

The element is constructed with 0,5 micron media and is therefore able to remove the smallest particles (silt) from the oil.

The filter material is composed primarily of cellulose, which is applied by a special wrapping method. Glass fibre and water absorbing elements are available on request.

The cellulose material is capable of retaining solid particles and absorbing water. This helps to prevent chemical deterioration of the oil and the formation of various acids and sludge.

Hydraulic cylinder extension for example, can draw air, solid contamination particles and water vapour into the oil reservoir.

The water vapour condenses due to temperature changes and causes not only oxidation of the oil, but can also lead to serious mechanical wear in the system.

Air Conditioning

Standard air filters remove a certain amount of solid particle contamination from the air but allow water vapour, to pass through.

The STAUFF "Air conditioners" type SDB and SVDB ensure that incoming air is first dried and then filtered. The SDB and SVDB units should be used in conjunction with the OLS / BPS Systems in order to provide a more complete filtering system. See Hydraulic Accessories section of this catalog, pages E30 to E33 for more details.

Advantages

- Less malfunction
- Protection of expensive main stream filters
- Less frequent oil changes
- Extended Usable life of the oil
- Less machine downtimes

Characteristics

- A filter fineness of 0,5 micron $B_{0,5} \geq 200, B_2 \geq 2330$
- Large particle collection capacity
- High filtration capacity due to depth effect
- Large water adsorption capacity
- Do not adversely affect viscosity or additives
- Do not remove additives
- Reduce the oxidation process
- Reduce the forming of acids
- With two measuring points for particle counter or oil sampling
- SAVE COSTS

Applications

- | | |
|---|---|
| <ul style="list-style-type: none"> ▪ Mining ▪ Harvesting ▪ Forestry ▪ Agricultural ▪ Off-road ▪ Fishing ▪ Road construction ▪ Cranes ▪ Airport equipment ▪ Flight simulators ▪ Pulp and paper ▪ Food processing | <ul style="list-style-type: none"> ▪ Presses ▪ Automotive industry ▪ Timber plants ▪ Plastic and rubber ▪ Metal industry ▪ Cement and concrete ▪ Material handling ▪ Bridges/Hydraulic locks/Water works ▪ Petrochemical industry ▪ Power stations ▪ Marine ▪ Steel |
|---|---|

Off-Line Filters ■ Type OLS
Product Description

STAUFF Off-Line Filter Units can be applied to every imaginable industrial application where hydraulic or lubrication systems are present.

An integrated motor/pump unit draws fluid out of the tank, filters it and pumps clean oil back into the system. Off-Line Filter Units can continue to work even when the main system is not in use. The standard range offers filter units for reservoirs with a capacity of up to 10800 l / 2853 gal.

Over the years, STAUFF Systems have developed considerable experience in the hydraulic and lubrication market cleaning systems to levels not previously possible with conventional methods.

With its integrated motor/pump unit STAUFF OLS Filter Systems are specially designed for Off-Line filtration of a hydraulic main system. This allows continuous filtration of the fluid even when the main system has been shut down.

The OLS is available with one, two or four filter housings and in two different lengths. The maximum flow for the Off-Line Unit goes from 2,1 ... 17 l/min / .55 ... 4.5 US GPM at a viscosity between 20 ... 160 cSt. For the OLS you can choose several different motor/pump units, for more information please see page C152 (Order code).

**All Off-Line Filter Systems are available with air driven motors.
These units are ideal for areas where electric power is unavailable
or for hazardous locations.**

Single Length (see page C148 / C149)

OLS - 1A - 30 - H - B

OLS - 2A - 30 - H - B

OLS - 4A - 30 - H - B

Double Length (see page C150 / C151)

OLS - 1B - 30 - H - B

OLS - 2B - 30 - H - B

OLS - 4B - 30 - H - B

Off-Line Filters ▪ Type OLS

Dimensions OLS - 1A - 30 - H - B

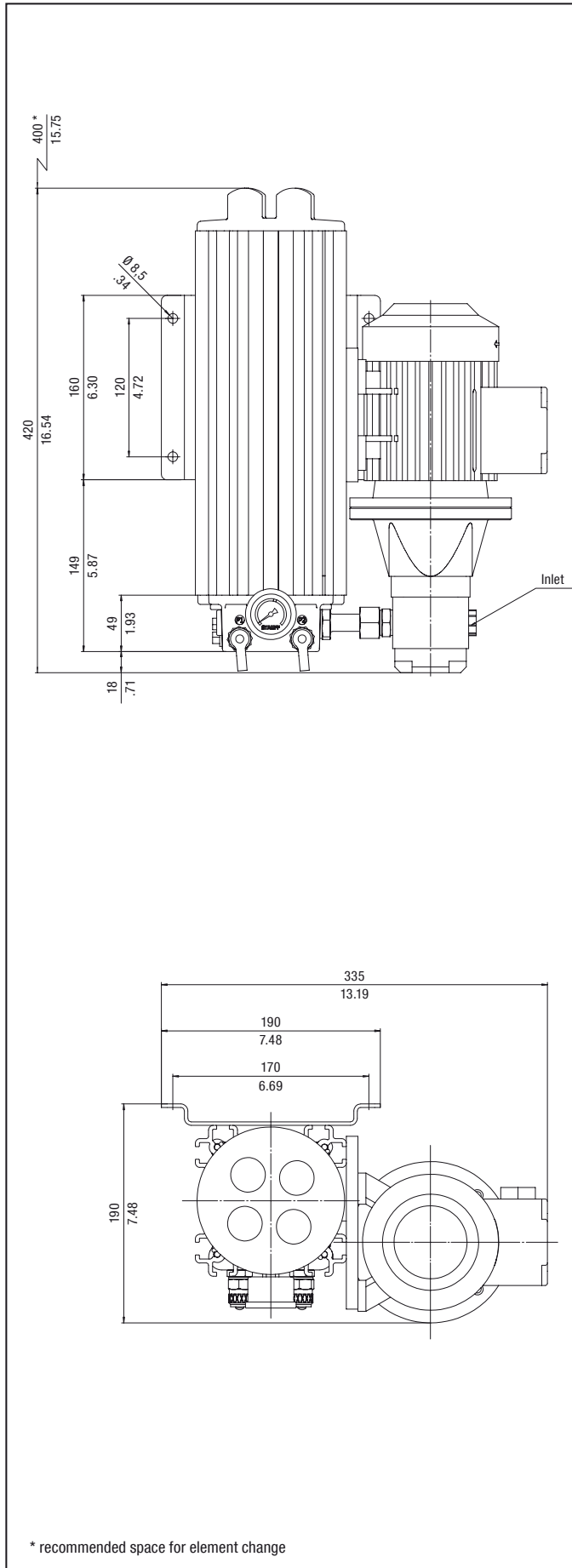

Dimensions OLS - 2A - 30 - H - B

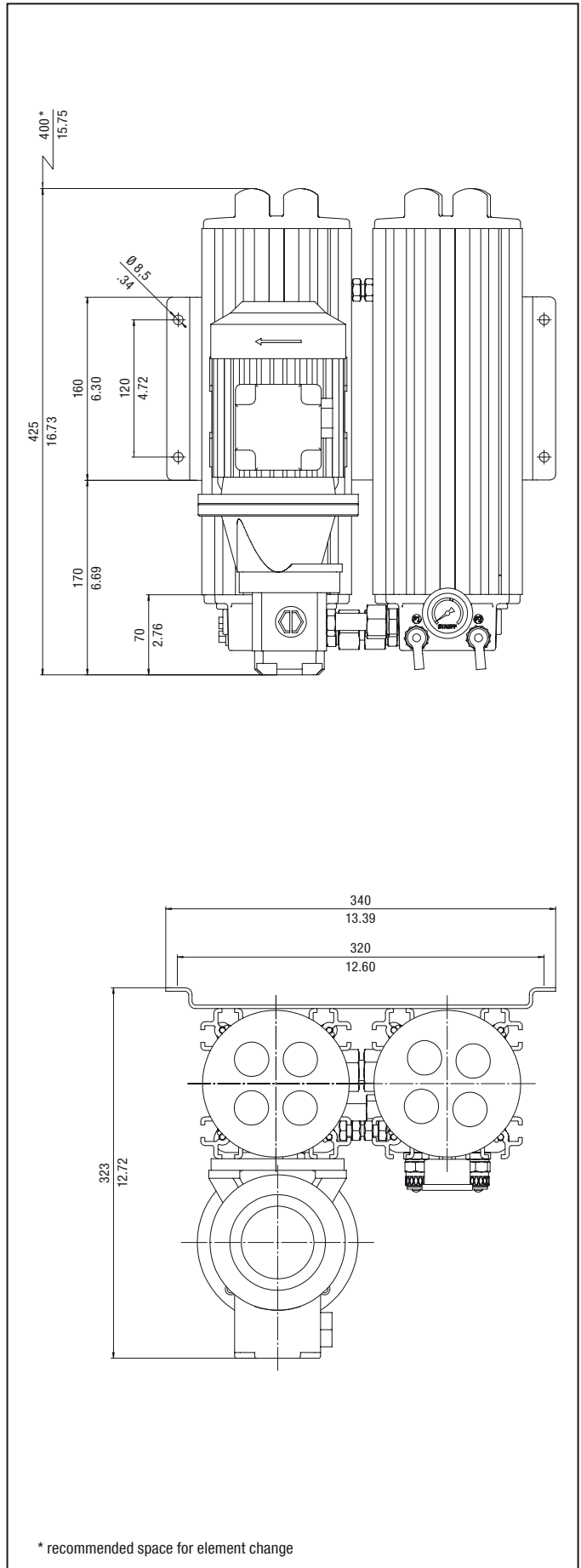

All dimensions in mm / in

Off-Line Filters ■ Type OLS

Dimensions OLS - 4A - 30 - H - B

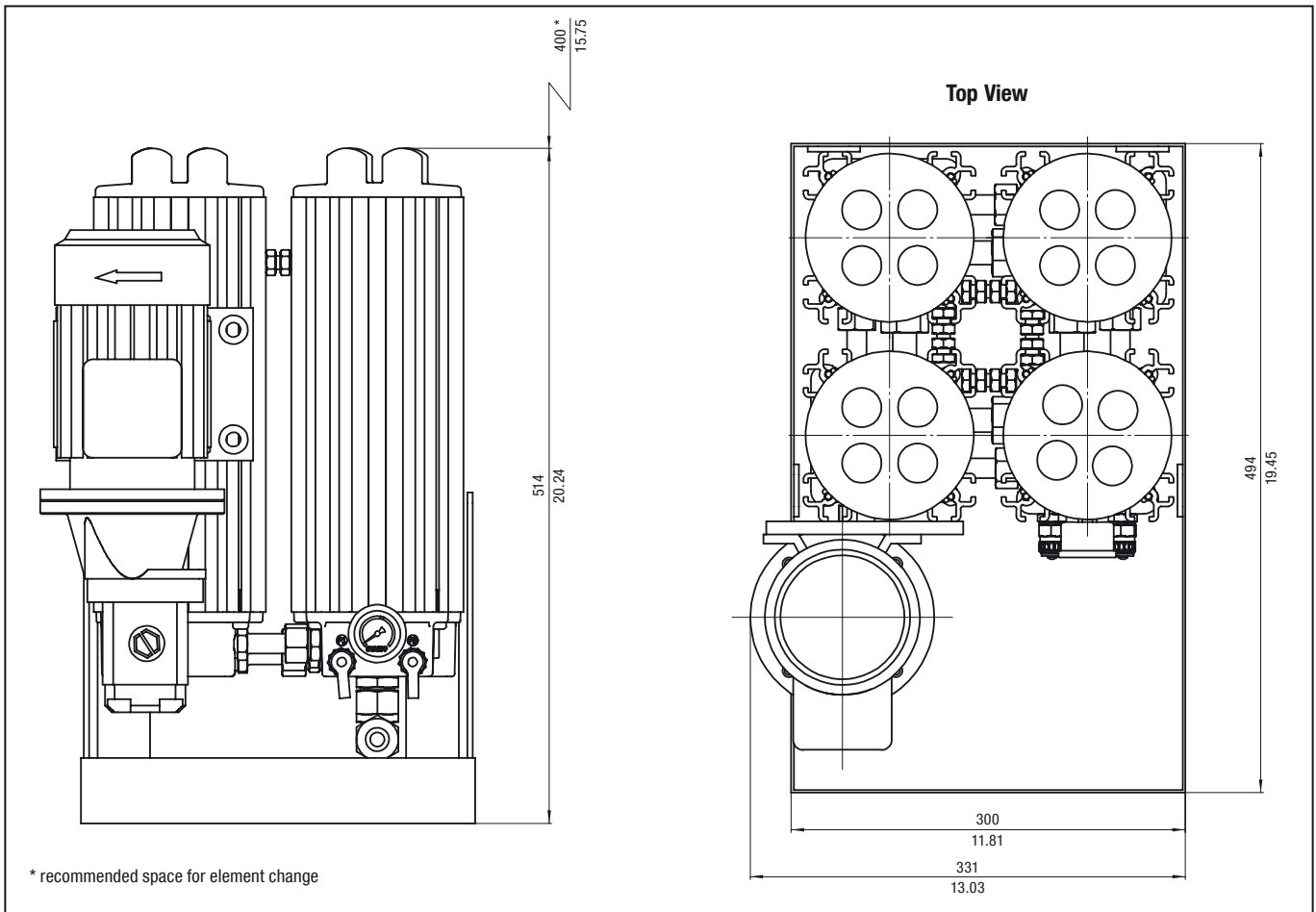

All dimensions in mm / in

Technical Data

	OLS-1A-30-H-B	OLS-2A-30-H-B	OLS-4A-30-H-B
Number of Filter Housings	1	2	4
Nominal Flow	2,1 l/min .55 US GPM	4,2 l/min 1.1 US GPM	8,4 l/min 2.22 US GPM
Max. Differential Pressure	Max. 6,2 bar 90 PSI over the filter element without backpressure		
Max. Fluid Temperature	+80 °C +176 °F		
Max. Housing Pressure	20 bar 290 PSI		
Viscosity Range	20 ... 160 cSt 100 ... 750 SUS		
Connection Suction Side	G3/8	G1/2	
Connection Return Line Side	G1/2		EW 18L-3/4
Hose Diameter	1/2 in (inner diameter) flexible hose		3/4 in (inner diameter) flexible hose
Weight (Including Element)	14 kg 30.9 lbs	21 kg 46.3 lbs	39 kg 86 lbs
Max. System Volume	1350 l 356 gal	2700 l 713 gal	5400 l 1426 gal
Dimensions	420 x 335 x 190 mm	425 x 340 x 323 mm	514 x 494 x 331 mm
HxWxD	16.54 x 13.19 x 7.48 in	16.73 x 13.39 x 12.72 in	20.24 x 19.45 x 13.03 in
Connection for Online Particle Counter	STAUFF Test (M16 x 2)		
Pump	Gear pump		
Motor	See page C152 for electric motor details		

Off-Line Filters ■ Type OLS

Dimensions OLS - 1B - 30 - H - B

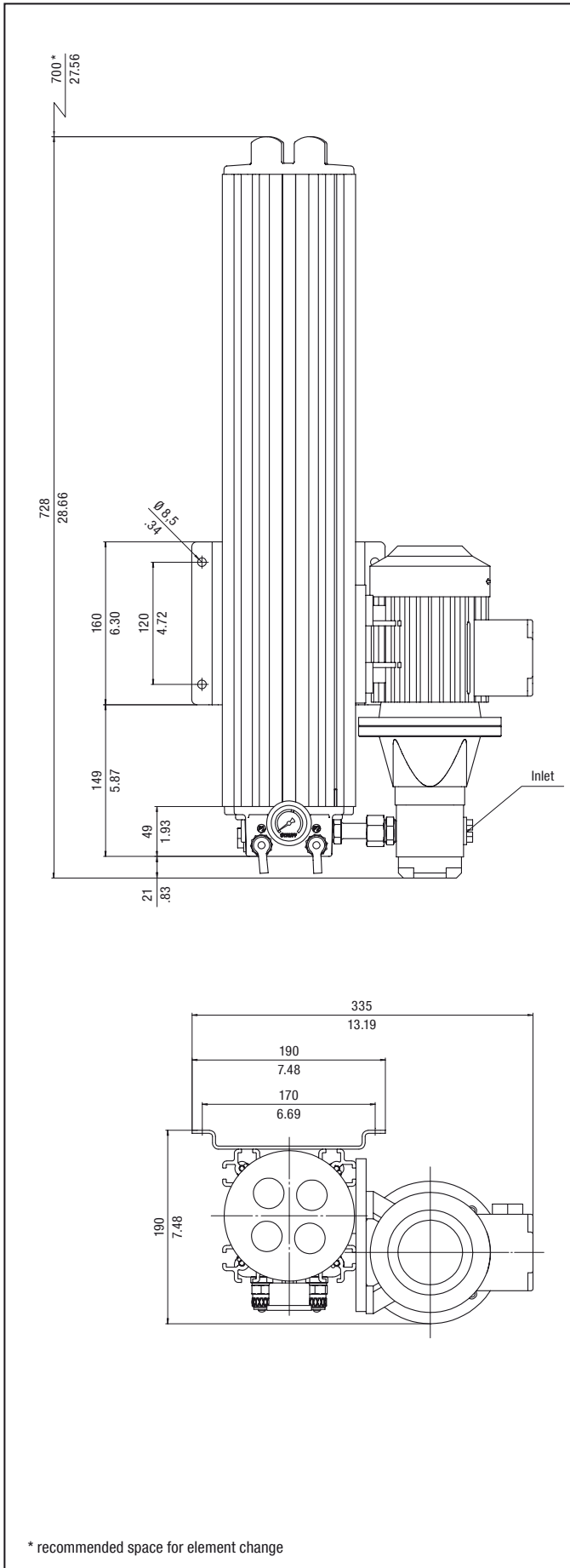

Dimensions OLS - 2B - 30 - H - B

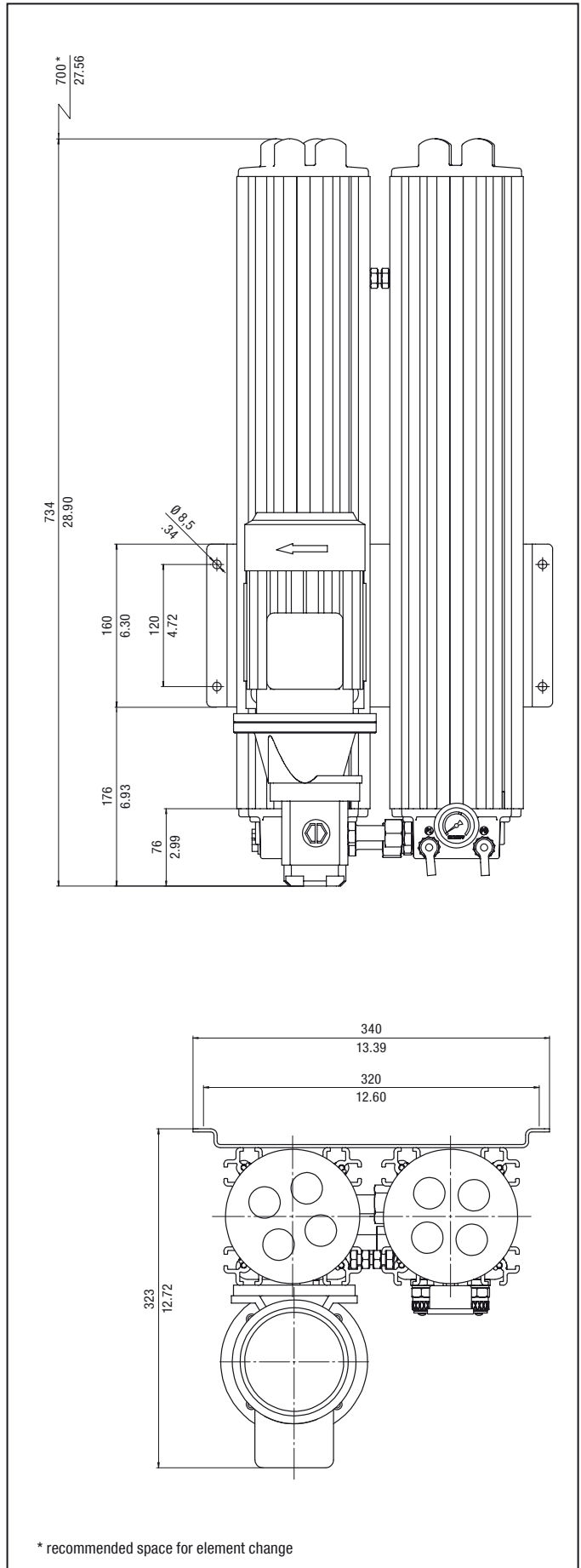

All dimensions in mm / in

Off-Line Filters ■ Type OLS

Dimensions OLS - 4B - 30 - H - B

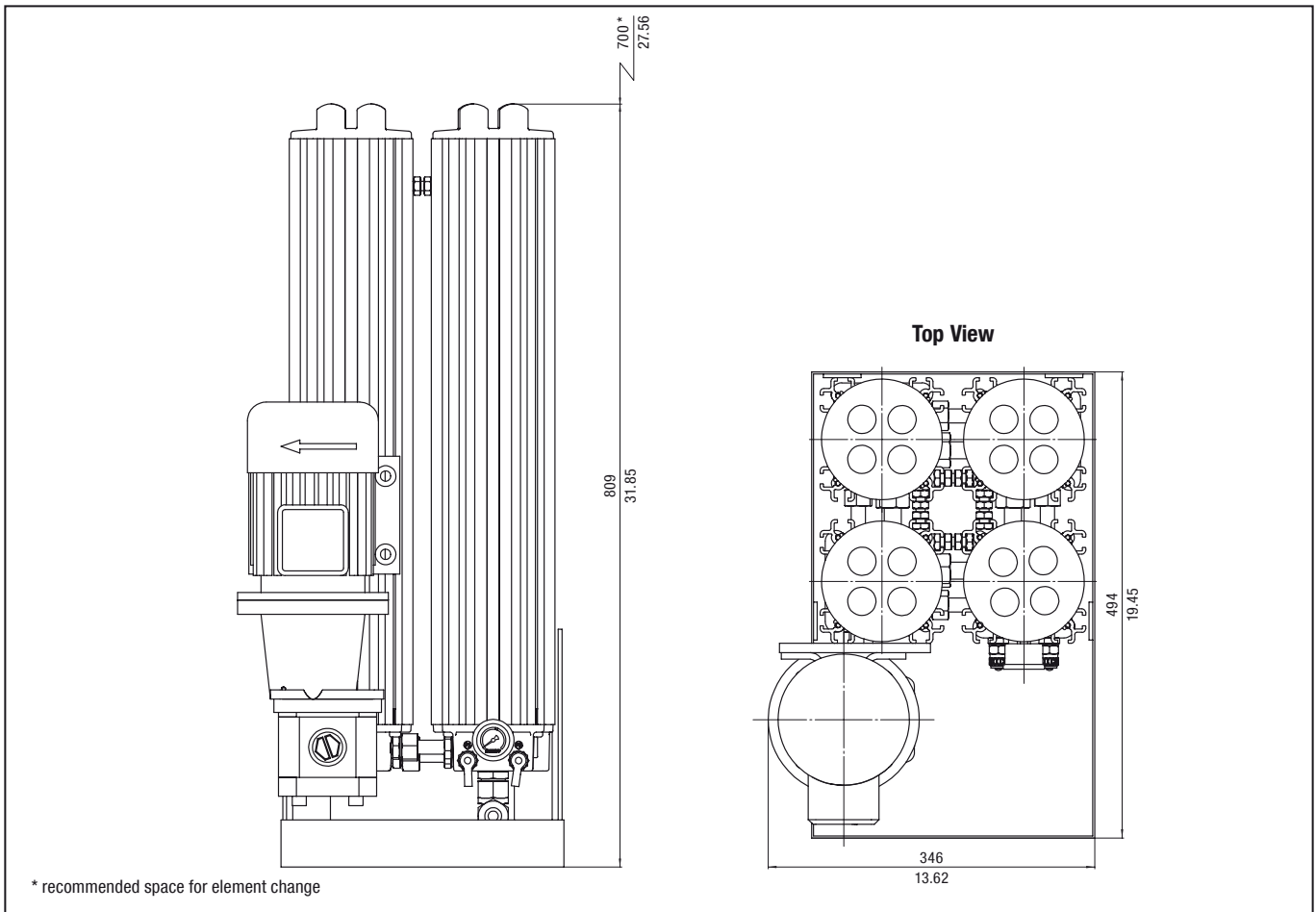

All dimensions in mm / in

Technical Data

	OLS-1B-30-H-B	OLS-2B-30-H-B	OLS-4B-30-H-B
Number of Filter Housings	1	2	4
Nominal Flow	4,2 l/min 1.1 US GPM	8,4 l/min 2.22 US GPM	17 l/min 4.5 US GPM
Max. Differential Pressure	Max. 6,2 bar 90 PSI over the filter element without backpressure		
Max. Fluid Temperature	+80 °C +176 °F		
Max. Housing Pressure	20 bar 290 PSI		
Viscosity Range	20 ... 160 cSt 100 ... 750 SUS		
Connection Suction Side	G1/2	G1/2	G3/4
Connection Return Line Side	G1/2		EW 18L-3/4 in
Hose Diameter	1/2 in (inner diameter) flexible hose		3/4 in (inner diameter) flexible hose
Weight (Including Element)	18 kg 39.7 lbs	30 kg 66.1 lbs	61 kg 134.5 lbs
Max. System Volume	2700 l 713 gal	5400 l 1426 gal	10800 l 2853 gal
Dimensions	728 x 335 x 190 mm	734 x 340 x 323 mm	809 x 494 x 346 mm
HxWxD	28.66 x 13.19 x 7.48 in	28.90 x 13.39 x 12.72 in	31.85 x 19.45 x 13.62 in
Connection for Online Particle Counter	STAUFF Test (M16 x 2)		
Pump	Gear pump		
Motor	See page C152 for electric motor details		

Off-Line Filter Housings / Complete Filters ▪ Type OLS

OLS - 1A - 30 - H - B - 0 - 01 - 0 - 0

1 2 3 4 5 6 7 8 9

1 Type

Off-Line Filter Unit **OLS**
(for industrial applications)

2 Housing Configuration

Single Length	Max. Reservoir Size	Quantity of Elements	Code
Single housing	1350 l / 356 gal	1x1	1A
Twin housing	2700 l / 713 gal	2x1	2A
Quadruple housing	5400 l / 1426 gal	4x1	4A

Double Length	Max. Reservoir Size	Quantity of Elements	Code
Single housing	2700 l / 713 gal	1x2	1B
Twin housing	5400 l / 1426 gal	2x2	2B
Quadruple housing	10800 l / 2853 gal	4x2	4B

3 Filter Element Length

300 mm / 11.81 in **30**

4 Filter Material and Micron Rating

Material	Micron rating µm	Code
Cellulose (standard)	0,5	H
Inorg. glass fibre	1	E01
Inorg. glass fibre	3	E03
Inorg. glass fibre	5	E05
Inorg. glass fibre	10	E10
Inorg. glass fibre	20	E20
Inorg. glass fibre and polymer (water absorption)	5	WA

5 Sealing Material

NBR (Buna-N®) (standard) **B**
FPM (Viton®) **V**

6 E-motor Options

Motor Type	Code
230/400 V AC, 50 Hz, three phases, 1360 r/min 255/460 V AC, 60 Hz, three phases, 1630 r/min (50 Hz and 60 Hz standard)	0
230 V AC, 50 Hz, single phase, 1360 r/min	A
24 V DC	B
110 V AC, 50 Hz, single phase	C
110 V AC, 60 Hz, single phase	D
230 V AC, 60 Hz, single phase, 1630 r/min	F

Note: Special motors on request.

7 Pump Options

50 Hz Motor	Standard in	Code
10 C 1,6X053G / 1,6 cc/rev.	OLS-1A	00
10 C 3,6X053G / 3,15 cc/rev.	OLS-2A/1B	10
10 C 6,1X053G / 6,1 cc/rev.	OLS-4A/2B	20
20 C 8,2X016G / 8,2 cc/rev.		30
20 C 11X016G / 11,3 cc/rev.	OLS-4B	40
MLPD/G 108C / 0,8 cc/rev.		50

60 Hz motor	Standard in	Code
10 C 1,25X053G / 1,25 cc/rev.	OLS-1A	01
10 C 2,5X053G / 2,5 cc/rev.	OLS-2A/1B	11
10 C 5X053G / 5,0 cc/rev.	OLS-4A/2B	21
20 C 6,3X016G / 6,3 cc/rev.		31
20 C 10X016G / 10 cc/rev.	OLS-4B	41

8 Clogging Indicator

Visual clogging indicator **0**

9 Mounting Options

No options (standard) **0**
Motor / pump right side mounted **1**
Motor / pump left side mounted **2**
Motor / pump horizontal front **3**

Filter Elements ▪ Type SRM

SRM - 30 - H - B - 1

1 2 3 4 5

1 Type

Filter Element Series **SRM**

2 Group

Element length 300 mm / 11.81 in **30**

3 Filter Material and Micron Rating

Material	Micron rating µm	Code
Cellulose (standard)	0,5	H
Inorg. glass fibre	1	E01
Inorg. glass fibre	3	E03
Inorg. glass fibre	5	E05
Inorg. glass fibre	10	E10
Inorg. glass fibre	20	E20
Inorg. glass fibre and polymer (water absorption)	5	WA

4 Sealing Material

NBR (Buna-N®) (standard) **B**
FPM (Viton®) **V**

5 Quantity

One piece filter element **1**
Box with 15 pieces filter element **15**

Technical Data on Electric Motors used for OLS Filters (For air driven motors contact Stauff)

E-motor	Standard Configuration	Description	Power in kW	Power in HP	Voltage 50 Hz	Amp 50 Hz	RPM 50 Hz	Voltage 60 Hz	Amp 60 Hz	RPM 60 Hz
C, D	OLS-1A OLS-2A OLS-1B	M63 B3/B5 4P 110V MULTIVOLT	0,18	0.24	110 V AC	3,30		110 V AC	2,70	
A, F	OLS-1A OLS-2A OLS-1B	M63 B3/B5 4P 230 MULTIVOLT	0,18	0.24	230 V AC	1,57		230 V AC	1,34	
0	OLS-1A OLS-2A OLS-1B	M63 B3/B5 4P 3PH MULTIVOLT	0,18	0.24	230/400 V AC	1,03 / 0,60		254/440 V AC	0,90 / 0,52	
0	OLS-2B OLS-4A	M63 B3/B5 4P 3PH MULTIVOLT	0,29	0.39	230/400 V AC	1,65 / 0,95	1460	254/440 V AC	1,47 / 0,85	1740
C, D	OLS-2B OLS-4A OLS-4B	M71 B3/B5 4P 110V MULTIVOLT	0,37	0.50	110 V AC	6,10		110 V AC	5,20	
A, F	OLS-2B OLS-4A OLS-4B	M71 B3/B5 4P 230V MULTIVOLT	0,37	0.50	230 V AC	3,00		230 V AC	2,65	
0	OLS-4B	M71 B3/B5 4P 3PH MULTIVOLT	0,37	0.50	230/400 V AC	1,90 / 1,10		254/440 V AC	1,60 / 0,93	

Water Absorbing Off-Line Filter ▪ Type OLSW

Product Description

STAUFF Systems Units are characterized by their extremely efficient filter elements which are rated to 0,5 micron. Specially designed for industrial hydraulic installations the STAUFF Off-Line Filters are available in single or double length configurations. The Off-Line Filter Units can easily be mounted to new and existing hydraulic installations. By means of an integrated motor/pump unit and an Off-Line Filter, the oil is pumped from the reservoir through the filter unit and after filtering the oil is then returned to the tank.

Economical

The hydraulic market accepts that 70 % of mechanical failures are caused by contamination in the system. The STAUFF Water Absorbing Off-Line Filters attack this contamination at source and in addition to solid particles, these filters are also capable of removing large quantities of water from the oil. This prevents the catalytic reaction of water and solid particle contamination, resulting in extended useable oil life.

The application of STAUFF Filters results in lower component failure rates, less down time and less system maintenance.

Water Absorbing

STAUFF Water Absorbing Filters are Off-Line Units that use special water absorbing Spin-On Filter Elements as a pre-filter. The fluid is pumped through the pre-filter which removes most water and larger solid contamination, in the second stage the fluid passes through the STAUFF Micro Filter where final water removal takes place as well as solid removal down to 0,5 micron.

In recent years STAUFF Systems have developed a great deal of experience in cleaning and drying hydraulic and lubrication systems in the following markets:

- Steel industry
- Maritime industry
- Petrochemical industry
- Paper industry

Advantages

- Extremely clean oil due to the high filtration efficiency $\beta_2 > 2330$
- Prevention of channel forming by radial filtration direction
- Increased flow capacity
- Increased dirt-hold capacity
- Large water holding capacity
- Compact and easy-maintenance design
- Longer usage life for oil and components



Water Absorbing Off-Line Filter - Type OLSW

Dimensions OLSW - 1A - 30

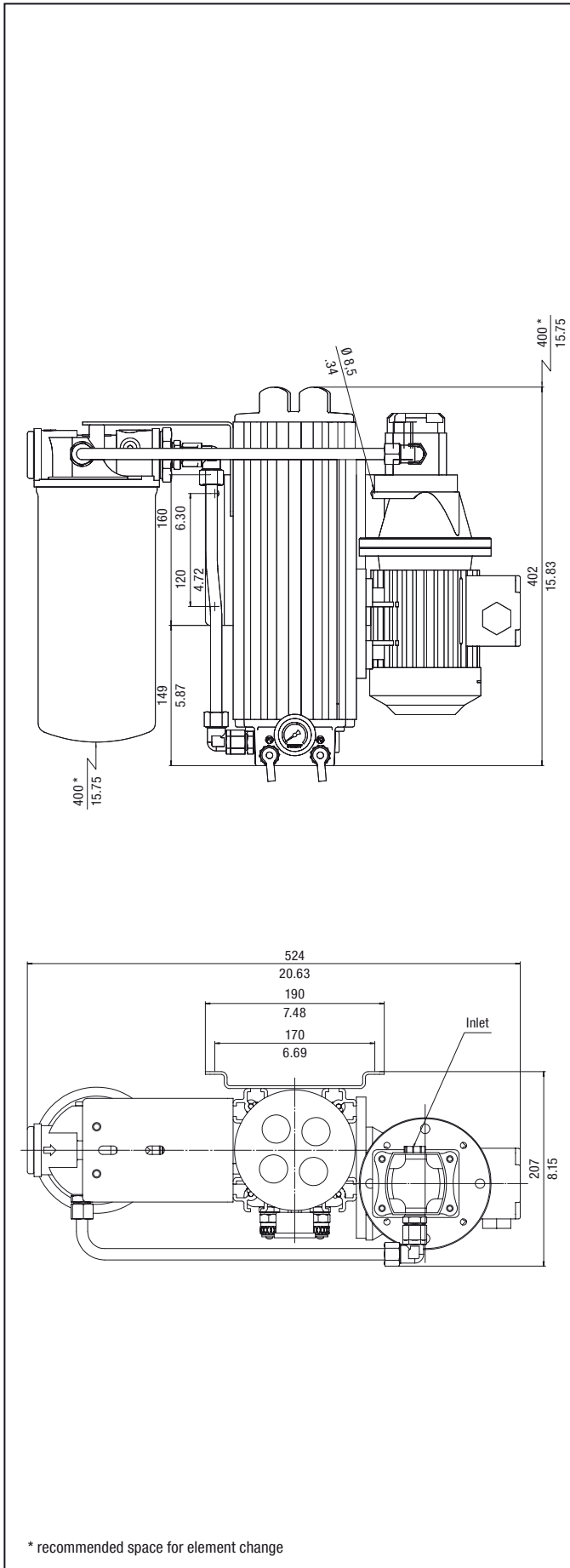

Dimensions OLSW - 1B - 30

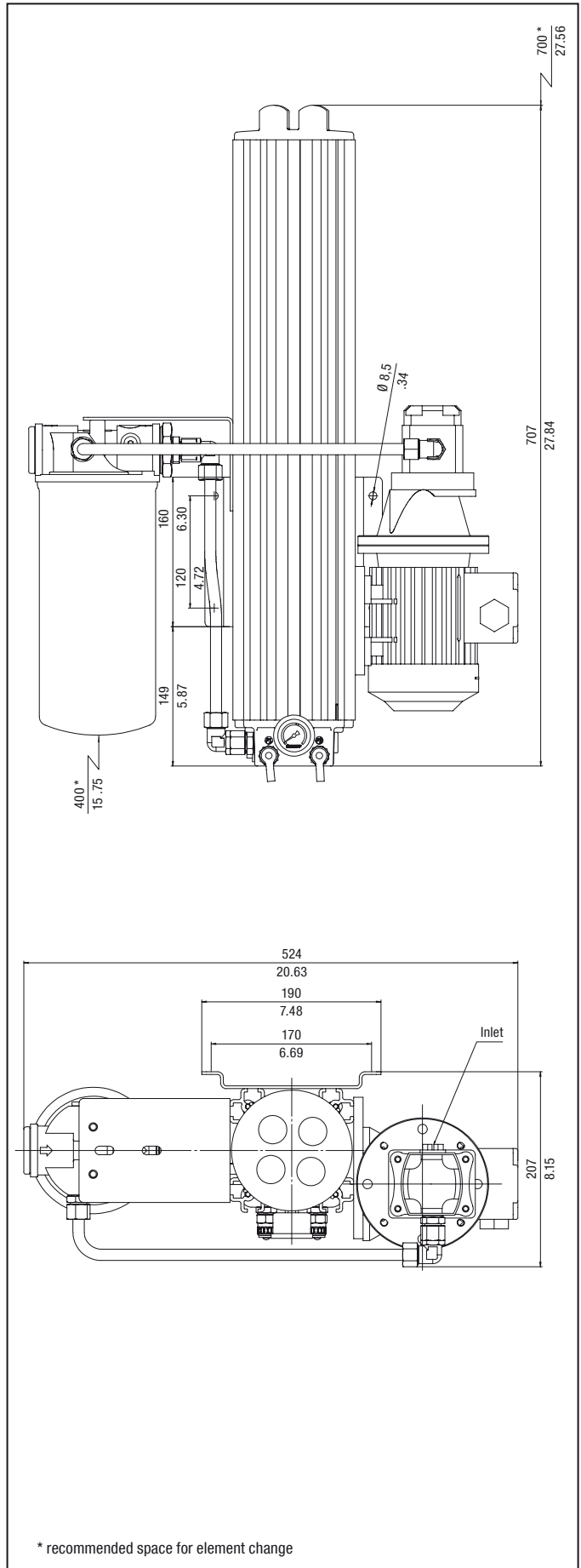

All dimensions in mm / in

Water Absorbing Off-Line Filter ■ Type OLSW
Technical Data OLSW

Type Filter	OLSW - 1A - 30 - H - B	OLSW - 1B - 30 - H - B
Number of Filter Housings	1	1
Material Filter Housings	Anodized Aluminum	
Sealing Material	Buna-N® (standard)	
Nominal Flow	2,1 l/min .6 US GPM	4,2 l/min 1.1 US GPM
Bypass Opening Pressure	6,2 bar 90 PSI over the filter element without backpressure	6,2 bar 90 PSI over the filter element without backpressure
Number of Standard Filter Elements	1 pcs.	2 pcs.
Number of Pre-Filter Elements	1 pcs.	1 pcs.
Water Absorbing Capacity	650 ml 22 oz.	800 ml 27 oz.
Max. Pressure Filter Housing	20 bar 290 PSI	
Max. Oil Temperature	+80 °C +176 °F	
Max. Viscosity	20 ... 160 cSt 100 ... 750 SUS	
Indicator Type	Visual clogging indicator	
Connection Pump Suction	G1/2 female	G1/2 female
Diameter Hose Suction Side	1/2 in	
Filter Return Connection	G1/2 female	
Diameter Hose Return Side	1/2 in	
Dimensions	402 x 524 x 207 mm	707 x 524 x 207 mm
H x B x L	15.83 x 20.63 x 8.15 in	27.84 x 20.63 x 8.15 in
Pump type	Gear pump	
Power Supply E-Motor	Various electrical power supplies possible	
Weight (including Element)	18 kg 39.7 lbs	22 kg 48.5 lbs
Max. System Volume	1350 liter 356 gal	2700 liter 713 gal
Standard Units for larger system volumes are also available		
Connection Oil-Analysis: P1 filter inlet side P2 filter outlet side	Test connector (M16 x 2) Red Test connector (M16 x 2) Red	

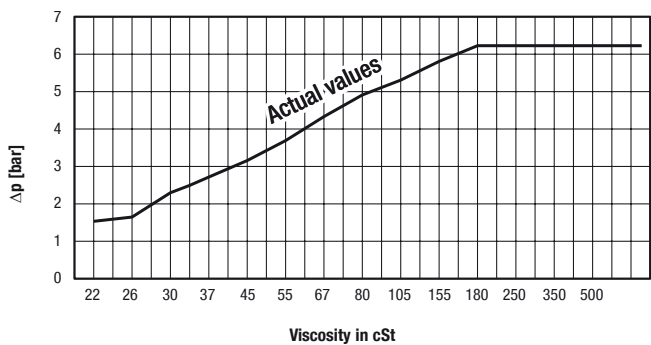
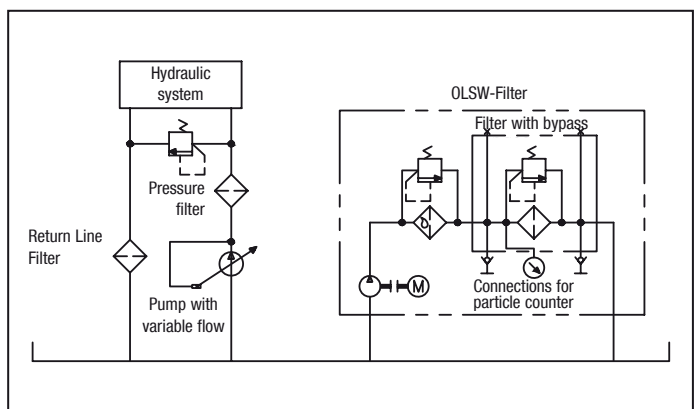
Water absorbing spin-on filter element
 Δp / Viscosity for OLSW-Filter

System Example
Schematic Off-Line Filtration incl. Water Absorption

Water Absorbing Off-Line Filter Housings / Complete Filters ▪ Type OLSW

OLSW - 1A - 30 - H - B - 0 - 01 - 0 - 0 - A

1 2 3 4 5 6 7 8 9 10

1 Type

Off-Line Filter Unit incl. water absorption **OLSW**
(for industrial applications)

2 Housing Configuration

Length	Suitable for Reservoir Size	Quantity of Elements Standard	Pre-filter	Code
Single housing Single length	1350 l / 356 gal	1x1 pcs	1 pcs	1A
Single housing Double length	2700 l / 713 gal	1x2 pcs	1 pcs	1B

3 Filter Element Length

300 mm / 11.81 in **30**

4 Filter Material and Micron Rating

Material	Micron rating µm	Code
Cellulose (standard)	0,5	H
Inorg. glass fibre	1	E01
Inorg. glass fibre	3	E03
Inorg. glass fibre	5	E05
Inorg. glass fibre	10	E10
Inorg. glass fibre	20	E20
Inorg. glass fibre and polymer (water absorption)	5	WA

5 Sealing Material

NBR (Buna-N®) (standard) **B**
FPM (Viton®) **V**

6 E-motor Options

Motor Type	Code
230/400 V AC, 50 Hz, three phases, 1360 r/min 255/460 V AC, 60 Hz, three phases, 1630 r/min (50 Hz and 60 Hz standard)	0
230 V AC, 50 Hz, single phase, 1360 r/min	A
24 V DC	B
110 V AC, 50 Hz, single phase	C
110 V AC, 60 Hz, single phase	D

Note: Other motors on request, technical data see page C152.

7 50 Hz Motor

	Standard in	Code
10C1,6X053G / 1,6 cc/rev.		00
10C3,6X053G / 3,15 cc/rev.		10
MLPD/G 108C / 0,8 cc/rev.		50

60 Hz Motor

	Standard in	Code
10C1,25X053G / 1,25 cc/rev.	OLSW-1A	01
10C2,5X053G / 2,5 cc/rev.	OLSW-1B	11

8 Clogging Indicator

Visual clogging indicator **0**

9 Mounting Options

No options (standard) **0**

10 Pre-Filter Elements

Water absorption element	
SF6721-W (10 micron water absorbing, capacity 540 ml water)	A
Pre-filter elements (particles)	
without pre-filter element	0
SF6702-MG (inorganic glass fibre, 1 micron)	B
SF6704-MG (inorganic glass fibre, 3 micron)	C
SF6707-MG (inorganic glass fibre, 6 micron)	D
SF6731-MG (inorganic glass fibre, 12 micron)	E
SF6726-MG (inorganic glass fibre, 25 micron)	F
SF6721 (filter paper, 10 micron)	G
SF6711 (filter paper, 25 micron)	H
SF6791 (wire mesh, 125 micron)	J

Filter Elements ▪ Type SRM

SRM - 30 - H - B - 1

1 2 3 4 5

1 Type

Filter Element Series **SRM**

2 Group

Element length 300 mm / 11.81 in **30**

3 Filter Material and Micron Rating

Material	Micron rating µm	Code
Cellulose (standard)	0,5	H
Inorg. glass fibre	1	E01
Inorg. glass fibre	3	E03
Inorg. glass fibre	5	E05
Inorg. glass fibre	10	E10
Inorg. glass fibre	20	E20
Inorg. glass fibre and polymer (water absorption)	5	WA

4 Sealing Material

NBR (Buna-N®) (standard) **B**
FPM (Viton®) **V**

5 Quantity

One piece filter element **1**
Box with 15 pieces filter element **15**

Pre-Filter Elements ▪ Type SF67

SF6721 - W

1

1 Pre-Filter Elements

SF6721-W	Spin-on filter element, water absorbing, 10 micron
SF6702-MG	Spin-on filter element, inorganic glass fibre, 1 micron
SF6704-MG	Spin-on filter element, inorganic glass fibre, 3 micron
SF6707-MG	Spin-on filter element, inorganic glass fibre, 6 micron
SF6731-MG	Spin-on filter element, inorganic glass fibre, 12 micron
SF6726-MG	Spin-on filter element, inorganic glass fibre, 25 micron
SF6721	Spin-on filter element, filter paper, 10 micron
SF6711	Spin-on filter element, filter paper, 25 micron
SF6791	Spin-on filter element, wire mesh, 125 micron

Heated Off-Line Filters ▪ Type OLSH

Product Description

STAUFF System Units are characterized by their pre-heating unit and extremely efficient filter elements with a fineness of 0,5 micron.

Specially designed for industrial hydraulic installations, the STAUFF Off-Line Filters are available in single or multiple housing configurations. The Off-Line Filter Units can easily be mounted to new and existing hydraulic installations.

By means of an integrated motor/pump unit and an Off-Line Filter, the oil is pumped from the reservoir through the filter unit and after filtering the oil is then returned to the tank.

Economical

The hydraulic market accepts that 70 % of the mechanical failures are caused by contamination in the system. The STAUFF Off-Line Filters attack this contamination at the source. In addition to solid particles, these filters are also capable of removing water from the oil. This prevents the catalytic reaction of water and solid particle contamination, resulting in extended usable life.

The application of STAUFF Filters results in lower component failure rates, less down time and less system maintenance.

In recent years STAUFF Systems have developed a great deal of experience in cleaning and drying hydraulic and lubrication systems in the following markets:

- Steel industry
- Maritime industry
- Petrochemical industry
- Paper industry

Heated Off-Line Filters

The electric pre-heating ensures that the cold and/or high viscosity fluid is brought to a temperature with a suitable filtration viscosity. Off-Line Filters with pre-heating can be applied to new or existing installations. The integrated pump-motor combination draws fluid from the reservoir, pumps it through a heating element, filters the fluid and returns it to the reservoir.

Advantages

- Extremely clean oil due to the high filtration efficiency $\beta_{0,5} \geq 200$, $\beta_2 \geq 2330$
- Prevention of channel forming by radial filtration direction
- Increased flow capacity
- Increased dirt holding capacity
- Large water holding capacity
- Compact and easy maintenance design
- Longer usage life for oil and components



Heated Off-Line Filters - Type OLSH

Dimensions OLSH - 1A

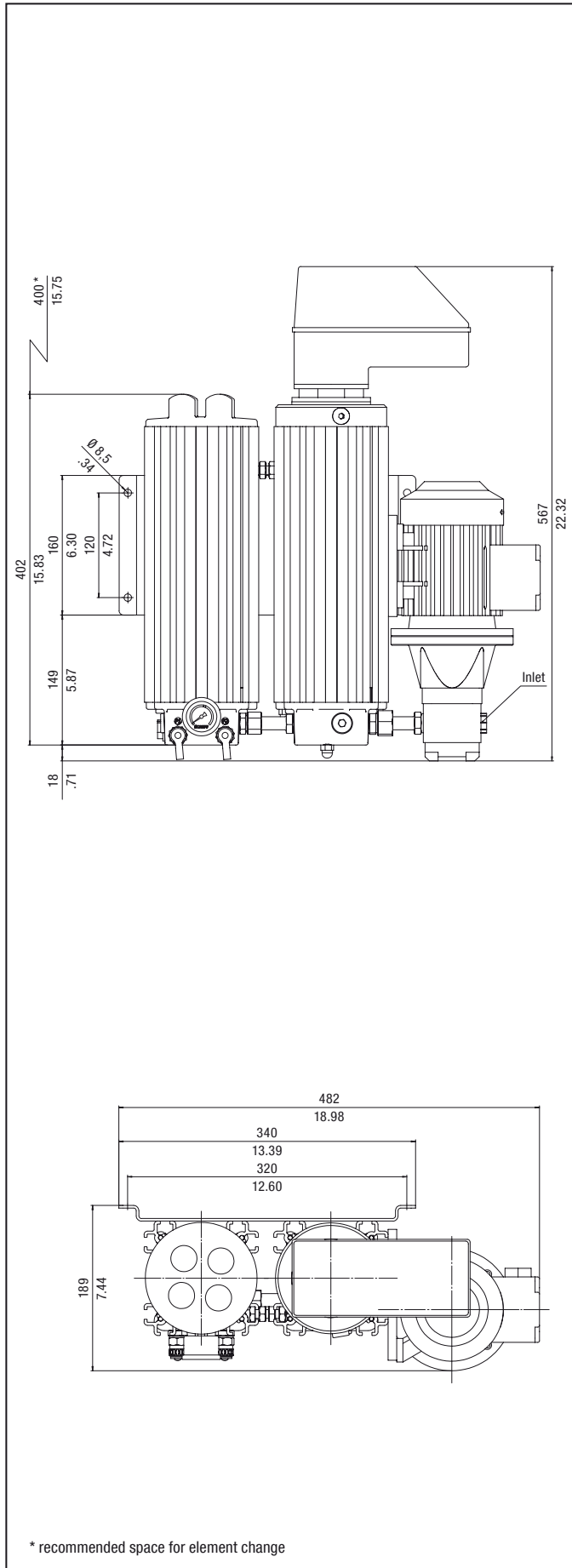

Dimensions OLSH - 1B

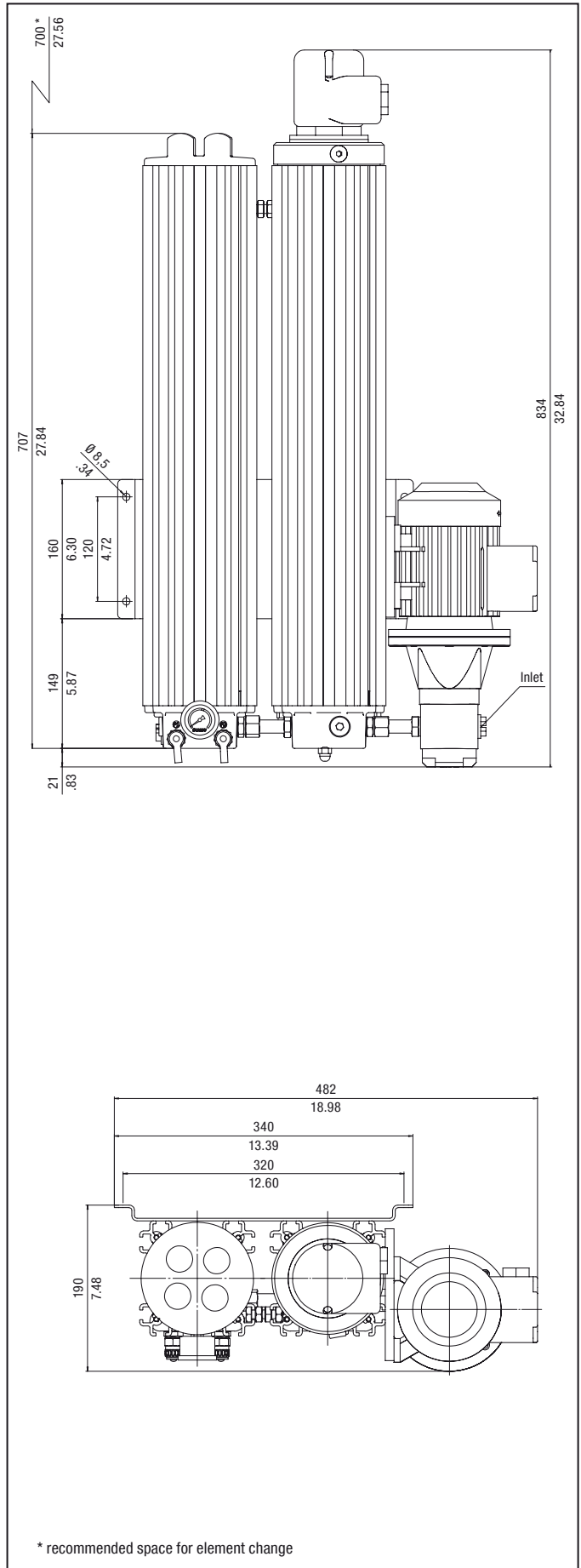

All dimensions in mm / in

Heated Off-Line Filters ▪ Type OLSH

Technical Data Heated Off-Line Filters

	OLSH - 1A - 30	OLSH - 1B - 30
Number of Filter Housings	1	1
Nominal Flow Rate	2,1 l/min .6 US GPM	4,2 l/min 1.2 US GPM
Max. Differential Pressure	Max. 6,2 290 PSI over the filter element without back pressure	
Max. Fluid Temperature	+80 °C +176 °F	
Max. Housing Pressure	20 bar 290 PSI	
Heater Capacity	2 kW	
Connection Suction Side	G3/8	
Connection Return Side	G1/2	
Hose Diameter	1/2 in ... 3/4 in (inner diameter) flexible hose	
Weight (including Element)	24 kg 44 lbs	28 kg 62 lbs
Max. System Volume	1350 l 356 gal	2700 l 713 gal
Dimensions H x W x D	567 x 482 x 189 mm 22.32 x 18.98 x 7.44 in	834 x 482 x 190 mm 32.84 x 18.98 x 7.48 in
Connection for On-Line Particle Counter	STAUFF Test (M16 x 2)	STAUFF Test (M16 x 2)
Pump	Gear Pump	
Motor	See page C160 for electric motor details	

STAUFF Heating Efficiency Curve

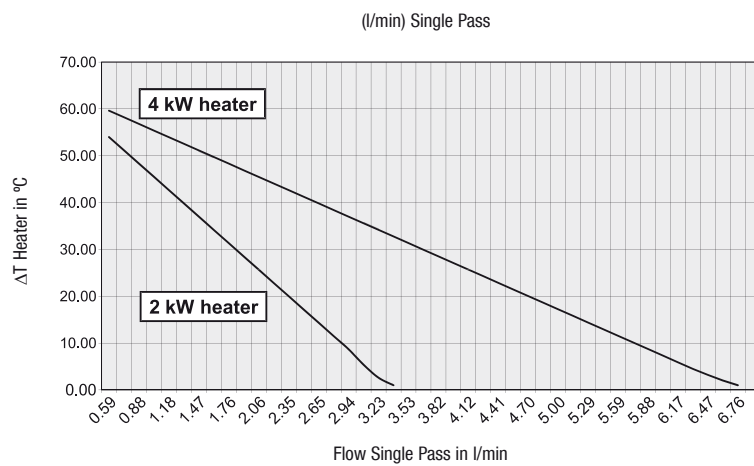

Heated Unit Hydraulic Schematic

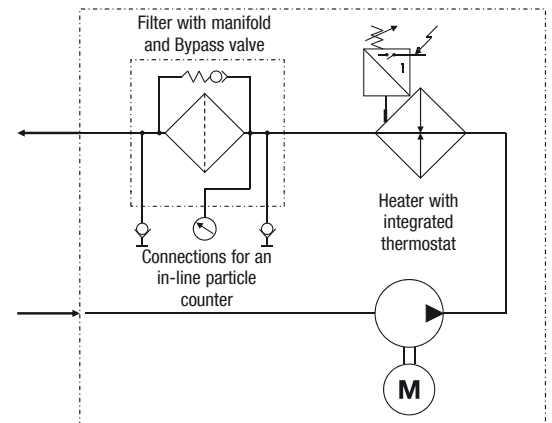

Heated Off-Line Filter Housings / Complete Filters - Type OLSH

OLSH - 1A - 30 - H - B - 0 - 00 - 0 - 0

1 2 3 4 5 6 7 8 9

1 Type

Heated Off-Line Filter Unit **OLSH**
(for industrial applications)

2 Housing Configuration

Length	Suitable for Reservoir Size	Quantity of Elements	Code
Single housing Single length	1350 l / 356 gal	1 pcs	1A
Single housing Double length	2700 l / 713 gal	2 pcs	1B

3 Filter Element Length

300 mm / 11.81 in **30**

4 Filter Material

Material	Micron Rating µm	Code
Cellulose (standard)	0,5	H
Inorg. glass fibre	1	E01
Inorg. glass fibre	3	E03
Inorg. glass fibre	5	E05
Inorg. glass fibre	10	E10
Inorg. glass fibre	20	E20
Inorg. glass fibre and polymer (water absorption)	5	WA

5 Sealing Material

NBR (Buna-N®) (standard) **B**
FPM (Viton®) **V**

6 E-Motor Options

Type	Code
230/400 V AC, 50 Hz, three phases, 1360 r/min 255/460 V AC, 60 Hz, three phases, 1630 r/min (50 Hz and 60 Hz standard)	0
230 V AC, 50 Hz, single phase	A
230/400 V AC, 50 Hz, three phases, IP65	E
230 V AC, 60 Hz, single phase, 1630 r/min	F

Note: Other motors on request, technical data see page C152.

7 Pump Options

Standard for 50 Hz Motor	Standard for	Code
10 C 1,6X053G / 1,6 cc/rev.	OLSH-1A	00
10 C 3,6X053G / 3,15 cc/rev.	OLSH-1B	10
1.0 cc / rev.		60

60 Hz Motor	Standard in	Code
10 C 1,25X053G / 1,25 cc / rev.	OLSH-1A	01
10 C 2,5X053G / 2,5 cc / rev.	OLSH-1B	11

8 Clogging Indicator

Visual clogging indicator **0**
With water sensor **1**

9 Mounting Options

No options (standard) **0**

Filter Elements - Type SRM

SRM - 30 - H - B - 1

1 2 3 4 5

1 Type

Filter Element Series **SRM**

2 Group

Element length 300 mm / 11.81 in **30**

3 Filter Material and Micron Rating

Material	Micron rating µm	Code
Cellulose (standard)	0,5	H
Inorg. glass fibre	1	E01
Inorg. glass fibre	3	E03
Inorg. glass fibre	5	E05
Inorg. glass fibre	10	E10
Inorg. glass fibre	20	E20
Inorg. glass fibre and polymer (water absorption)	5	WA

4 Sealing Material

NBR (Buna-N®) (standard) **B**
FPM (Viton®) **V**

5 Quantity

One piece filter element **1**
Box with 15 pieces filter element **15**

Bypass Filters ▪ Type BPS

Product Description

STAUFF BPS Bypass Filter can be used for OEM first fit applications as well as for retro-fitting. The filtration is done in a bypass configuration from the main hydraulic system. The STAUFF BPS Filter Systems are available with one filter housing (BPS-1A, maximum flow 2,1 l/min / .6 US GPM) or with two filter housings (BPS-2A, maximum flow 4,2 l/min / 1.1 US GPM) at a viscosity between 20 ... 160 cSt / 100 ... 750 SUS.

The STAUFF Bypass Filter Units are especially designed for mobile applications in hydraulic and/or transmission systems.

In the absence of a pumped system, the oil is drawn from the main system by means of a specially designed and integrated flow valve. The amount of oil extracted at any one time is insignificant therefore ensuring that it will not affect the working of the main system.

Most commonly used biodegradable oils in the mobile sector are suitable for filtration with STAUFF Filter Elements.

STAUFF Systems have been applied on a wide range of mobile hydraulic machinery, cleaning fluids to levels not previously possible with conventional filtration methods, resulting in dramatic increases in component life.

Successful applications include:

- Excavators
- Wheel loaders
- Forestry machines
- Asphaltting machines
- Cement mixers
- Aircraft ground support machinery
- Agricultural machines

BPS - 1A - 30 - H - B

BPS - 2A - 30 - H - B

Bypass Filters - Type BPS

Dimensions BPS - 1A - 30 - H - B

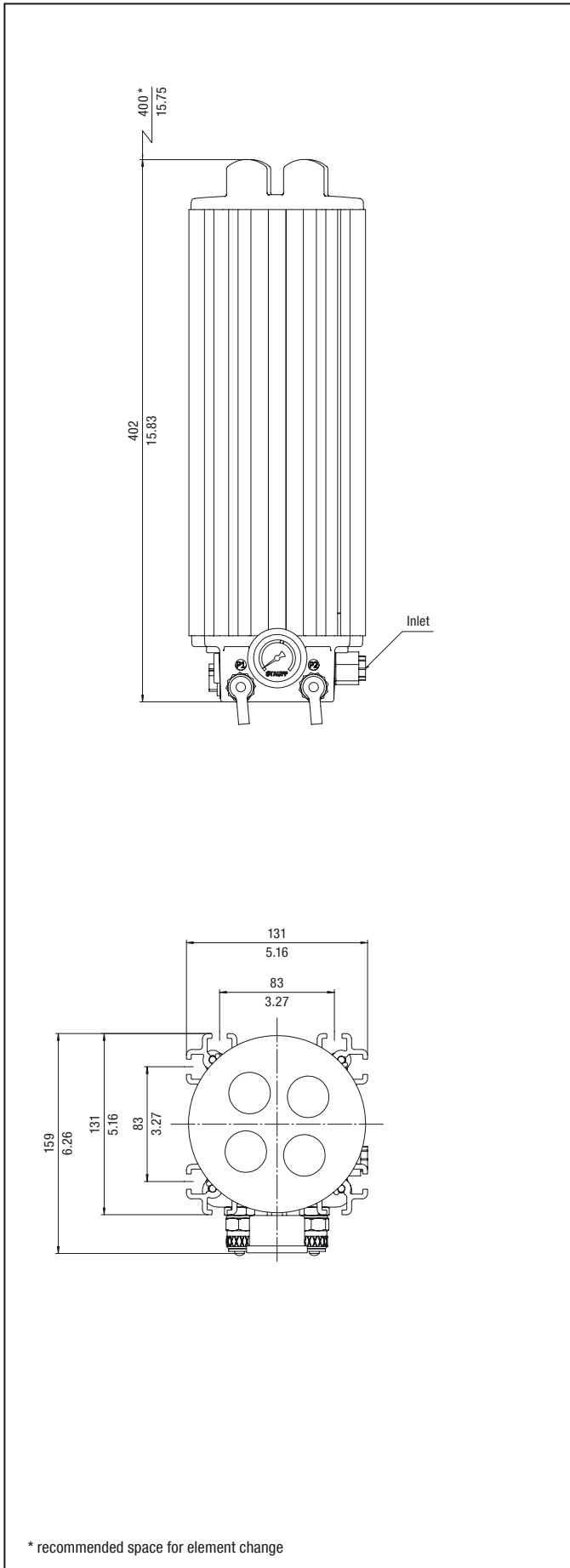

Dimensions BPS - 2A - 30 - H - B

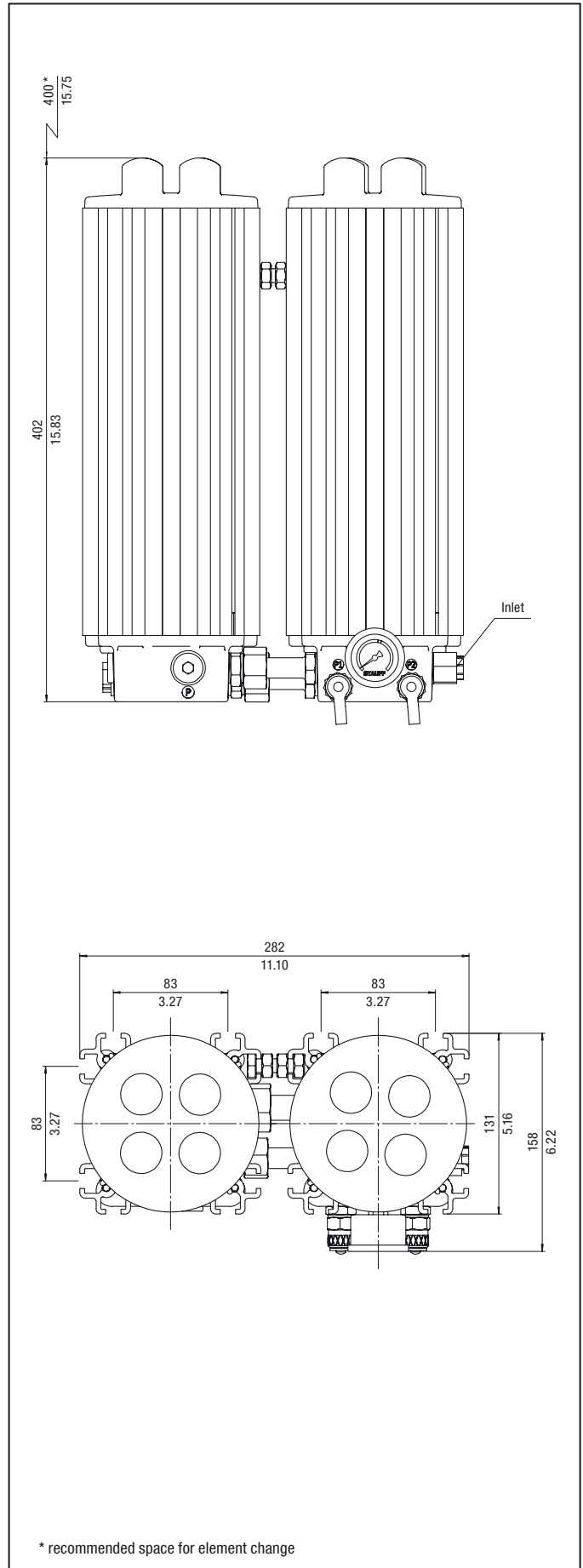

All dimensions in mm / in

Bypass Filters ■ Type BPS

Technical Data BPS

	BPS - 1A - 30 - H - B	BPS - 2A - 30 - H - B
Number of Filter Housings	1	2
Nominal Flow	2,1 l/min .6 US GPM	4,2 l/min 1.1 US GPM
Max. Differential Pressure	Max. 6,2 90 PSI over the filter element without back pressure	
Max. Fluid Temperature	+80 °C +176 °F	
Max. Housing Pressure	20 bar 290 PSI	
Range of Viscosity	20 ... 160 cSt 100 ... 750 SUS	
Connection Pressure Side	G1/4	
Connection Return Line Side	G1/2	
Hose Diameter	3/8 ... 1/2 in (inner diameter) flexible hose	
Weight	6 kg 13.2 lbs	13 kg 28.7 lbs
Max. Volume of Tank	750 l 200 gal	1500 l 400 gal
Dimensions	402 x 131 x 159 mm	402 x 282 x 158 mm
H x W x D	15.83 x 5.16 x 6.26 in	15.83 x 11.10 x 6.22 in
Connection for On-Line Particle Counter	STAUFF Test (M16 x 2)	
Pressure Range	12 ... 420 bar 180 ... 6200 PSI	

Bypass Filter Housings / Complete Filters ■ Type BPS

BPS -
 1A -
 30 -
 H -
 B -
 0 -
 0 -
 0

1
 2
 3
 4
 5
 6
 7
 8

1 Type

Bypass Filter Unit (for mobile applications)	BPS
---	------------

2 Housing Configuration

Length	Suitable for Reservoir Size	Number of Elements	Code
Single housing	750 l / 198 gal	1x1 pcs	1A
Twin housing	1500 l / 396 gal	2x1 pcs	2A

3 Filter Element Length

300 mm / 11.81 in	30
-------------------	-----------

4 Filter Material and Micron Rating

Material	Micron Rating µm	Code
Cellulose (standard)	0,5	H
Inorg. glass fibre	1	E01
Inorg. glass fibre	3	E03
Inorg. glass fibre	5	E05
Inorg. glass fibre	10	E10
Inorg. glass fibre	20	E20
Inorg. glass fibre and polymer (water absorption)	5	WA

5 Sealing Material

NBR (Buna-N®) (standard)	B
FPM (Viton®)	V

6 Clogging Indicator

Visual clogging indicator	0
---------------------------	----------

7 Valve Options

With flow control valve (standard)	0
Without flow control valve	1

8 Mounting Options

No bracket (standard)	0
With standard foot / bulk head mounting bracket	1
With "bulk head mounting only" bracket	2
With standard 'OLS' wall mounting bracket	3

Note: For details see page C164

Filter Elements ■ Type SRM

SRM -
 30 -
 H -
 B -
 1

1
 2
 3
 4
 5

1 Type

Filter Element Series	SRM
-----------------------	------------

2 Group

Element length 300 mm / 11.81 in	30
----------------------------------	-----------

3 Filter Material and Micron Rating

Material	Micron Rating µm	Code
Cellulose (standard)	0,5	H
Inorg. glass fibre	1	E01
Inorg. glass fibre	3	E03
Inorg. glass fibre	5	E05
Inorg. glass fibre	10	E10
Inorg. glass fibre	20	E20
Inorg. glass fibre and polymer (water absorption)	5	WA

4 Sealing Material

NBR (Buna-N®) (standard)	B
FPM (Viton®)	V

5 Quantity

One piece filter element	1
Box with 15 pieces filter element	15

Bypass Filters - Type BPS

With Standard Foot / Bulk Head Mounting Bracket (Code 1)

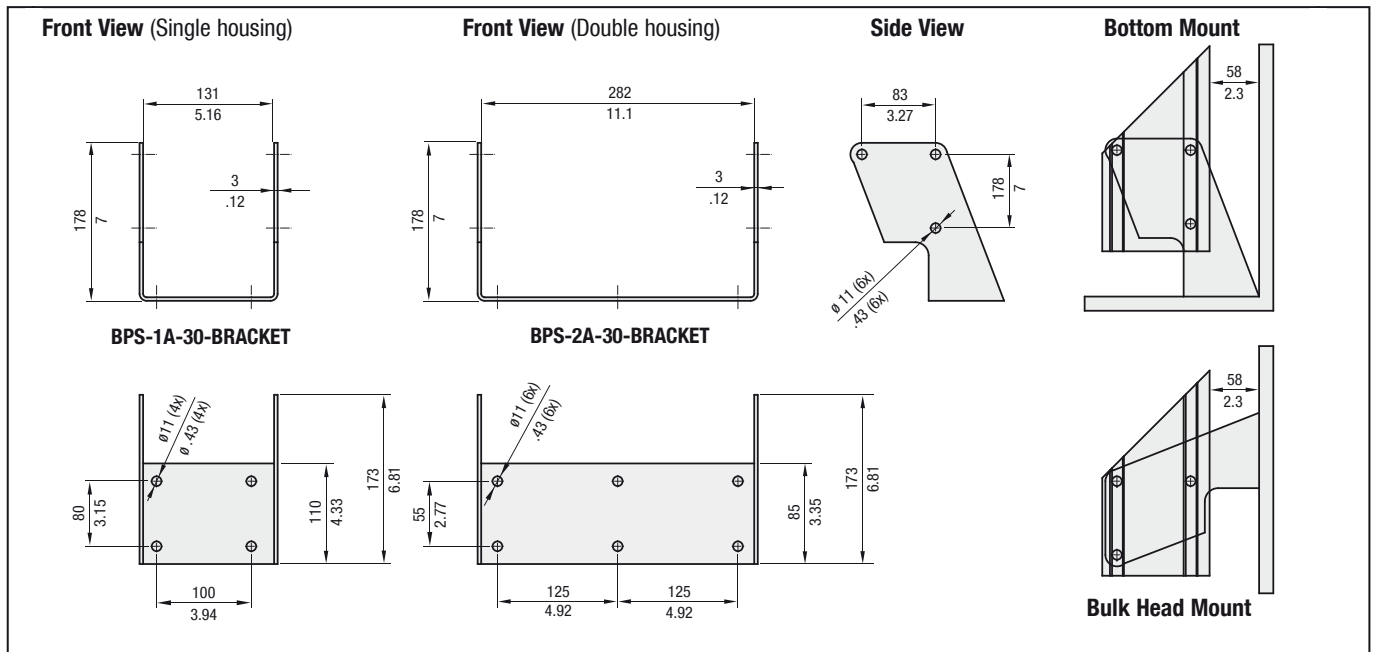

All dimensions in mm / in

With "Bulk Head Mounting Only" Bracket (Code 2)

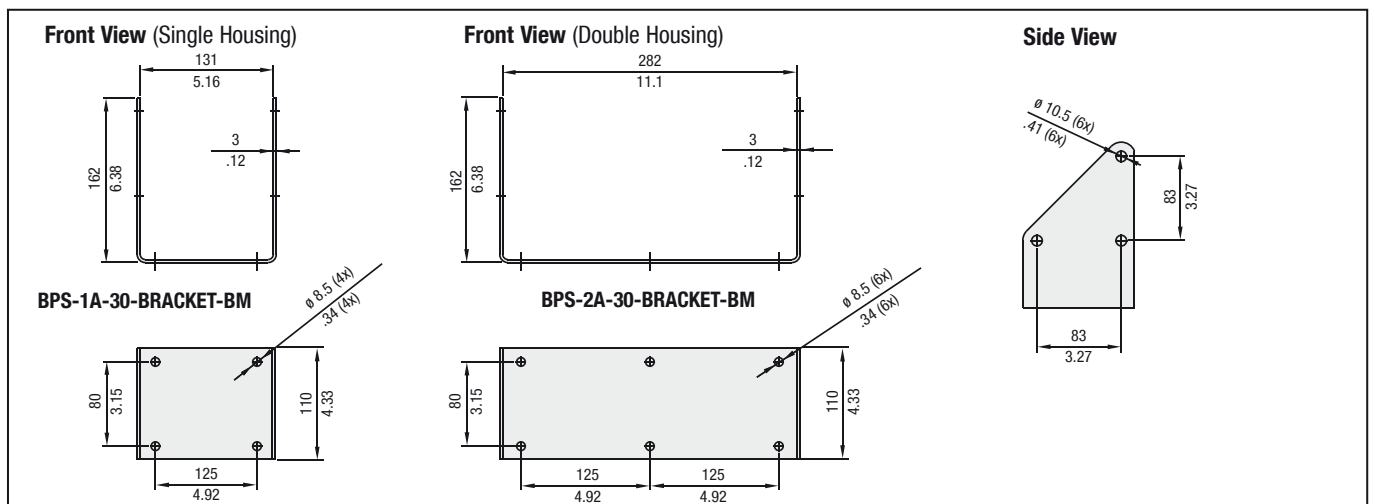

All dimensions in mm / in

Standard "OLS" Wall Mounting Bracket (Code 3)

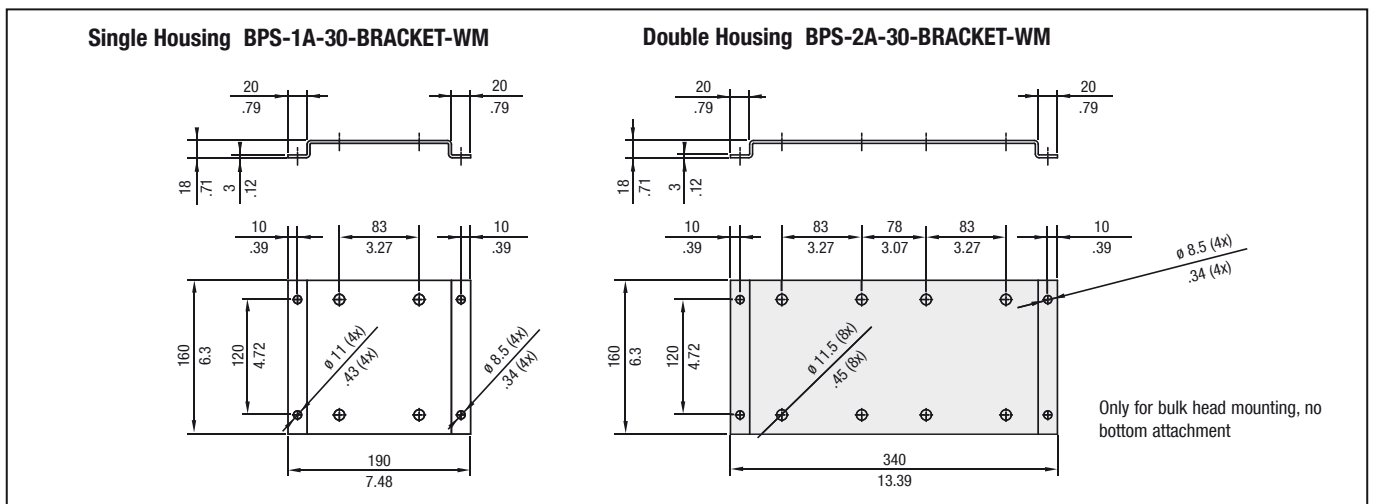

All dimensions in mm / in

Bypass and Off-Line Filters ▪ Type OLS / BPS

Off-Line Filter OLS Hydraulic Symbol

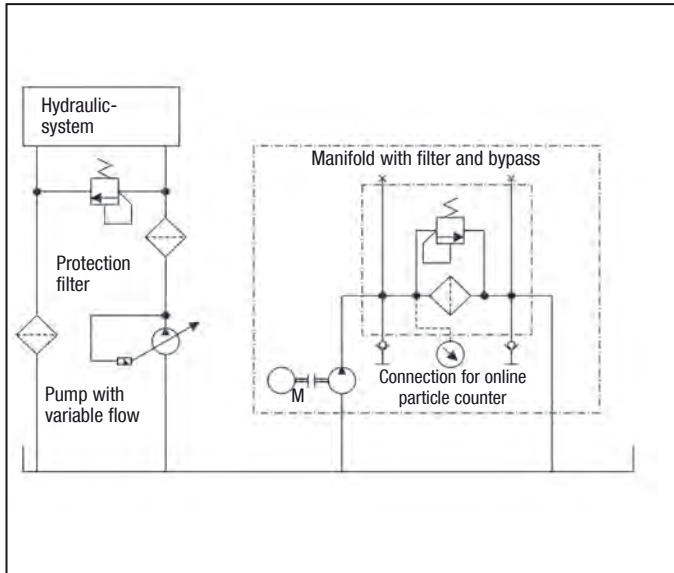

Bypass Filter BPS Hydraulic Symbol

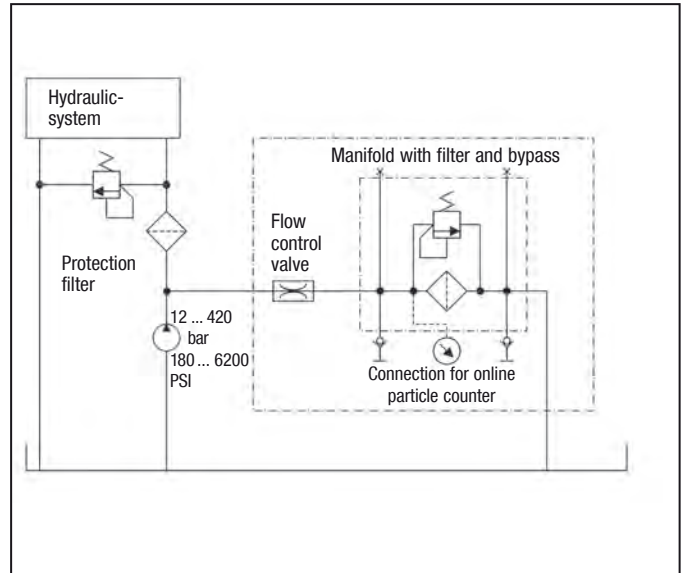
 Filter Element SRM-30HB Δp / viscosity - graph

(at a flow of 2,1 l/min / .6 US GPM per element)

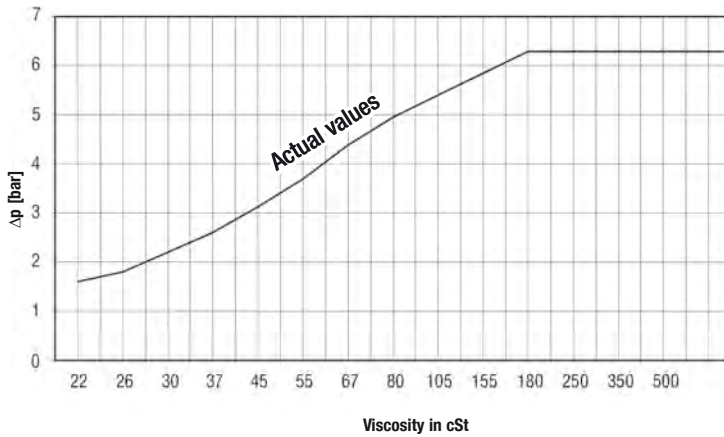

Flow Characteristics Off-Line Filter OLS with Filter Element SRM-30HB (at maximum viscosity)

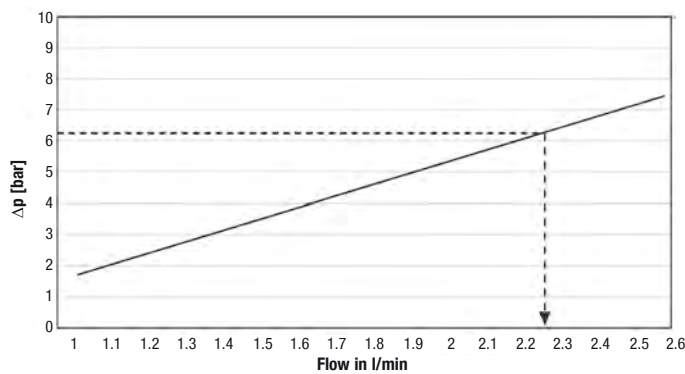

Flow Characteristics Bypass Filter BPS with Filter Element SRM-30HB (at maximum viscosity)

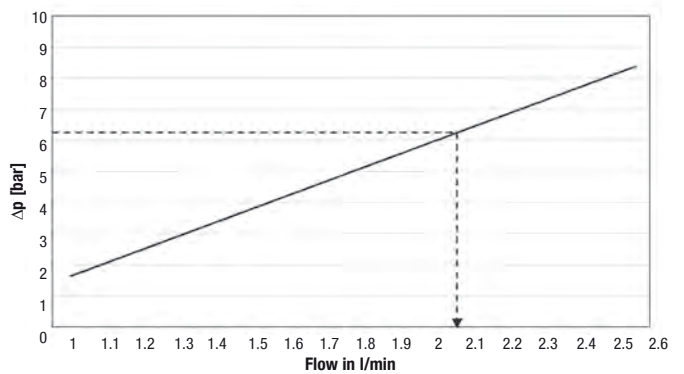

Bypass Lube-Oil Filter ■ Type BPLS

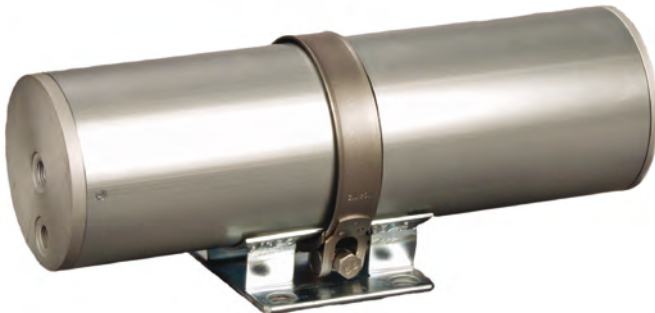

Product Description

Maintenance is essential for the efficient functioning of engine equipment. However, it is always a critical decision between the quality of the maintenance and the costs involved. Optimal maintenance efficiency combines maximum achievement of the maintenance goal (protection and prolonged usage life of the object) with minimal use of means (costs). The STAUFF Bypass Filter is unique in that it not only achieves the goal, but saves on costs.

The STAUFF Bypass Filter keeps the oil clean, resulting in significant technical, environmental and financial benefits thanks to reduced wear and tear on equipment and machines and prolonged oil life time.

STAUFF Systems BPLS Bypass Filters are used as an additional micro filter connected in bypass to the conventional main stream filters on engines (and automatic transmissions.) Most contamination is much smaller than 15 micron in size, but full flow filters generally do not filter below this level. This results in a lot of harmful contamination passing through these filters and remaining in the system. STAUFF Systems Bypass Filters are capable of filtering down as low as 0,5 micron without detriment to the lubrication circuit. (see schematic)

Whatever the application, the benefits of the STAUFF Systems Bypass Filters are all based on maintaining a higher quality and cleanliness level of the oil and thereby avoiding the multiple problems that can be caused by fluid contamination.

The benefits are many, and can be broken into three categories :

Technical benefits

- Less malfunctioning
- Greater reliability of operation
- Prolonged oil usage life
- Reduced down time
- Reduced wear on cylinder linings and pistons
- Less bore polishing
- Less formation of black sludge
- Improved engine compression
- Increased equipment life time

Environmental benefits

- Less oil consumption
- Therefore less waste oil
- Increased life time of additives
- Reduction of harmful emissions

Financial benefits

- Savings in labour and materials (oil changes)
- Reduced costs for repairs and downtime
- Reduced waste processing costs

Applications

- Construction equipment
- Agricultural equipment
- Forestry equipment
- Diesel driven welding machines/generators
- Port equipment

Maximum Sump Size

- 35 l / 9.25 gal

Housing Volume

- 2,2 liter / .58 gal

Burst Pressure Housing

- > 20 bar / >290 PSI

Filter Element

- 0,5 micron cellulose element
- Glass fibre elements (pleated)
- Water absorbing elements

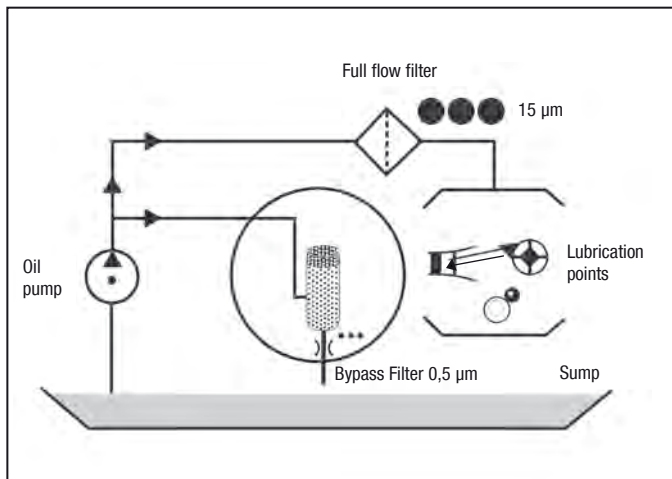

Technical Data

Construction

- BPLS: Bypass Lube-Oil Filter

Materials

- Filter housing: Aluminium
- Sealings: NBR (Buna-N®)
FPM (Viton®)

Port Connection

- Inlet: G1/4
- Outlet: G1/4

Bypass Lube Oil Filter - Type BPLS

BPLS-Filter Dimensions

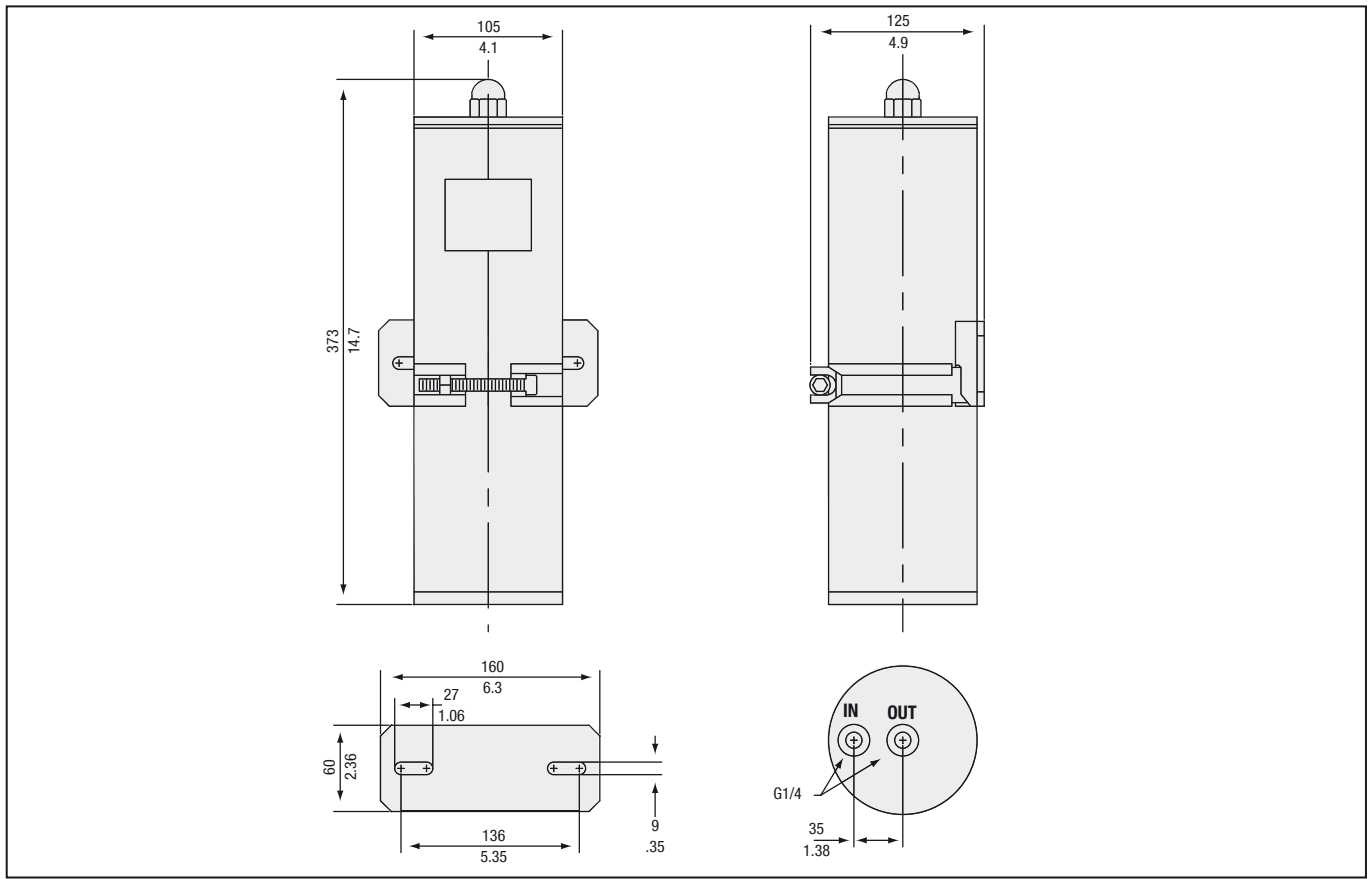

All dimensions in mm / in

Bypass Lube Oil Filter Housings / Complete Filters - Type BPLS

BPLS - 1A - 26 - H - B - 0 - 0 - 0

1 2 3 4 5 6 7 8

1 Type

 Bypass Lube-Oil Filter **BPLS**
 (for engines and transmission systems)

2 Housing Configuration

Length	Quantity of elements	Code
Single housing	1 pcs element - (281 mm)	1A

3 Filter Element Length

 281 mm / 11.06 in **26**
4 Filter Material and Micron Rating

Material	Micron Rating μm	Code
Cellulose (standard)	0,5	H
Inorg. glass fibre	1	E01
Inorg. glass fibre	3	E03
Inorg. glass fibre	5	E05
Inorg. glass fibre	10	E10
Inorg. glass fibre	20	E20
Inorg. glass fibre and polymer (water absorption)	5	WA

5 Sealing Material

 NBR (Buna-N®) (standard) **B**
 FPM (Viton®) **V**
6 Housing Material

 Aluminium (standard) **0**
7 Options

 No options **0**
8 Bracket Options

 No mounting bracket **0**
 Standard mounting bracket (bulkhead) **1**

Filter Elements - Type SRM

SRM - 26 - H - B - 1

1 2 3 4 5

1 Type

 Filter Element Series **SRM**
2 Group

 Element length 281 mm / 11.06 in **26**
3 Filter Material and Micron Rating

Material	Micron rating μm	Code
Cellulose (standard)	0,5	H
Inorg. glass fibre	1	E01
Inorg. glass fibre	3	E03
Inorg. glass fibre	5	E05
Inorg. glass fibre	10	E10
Inorg. glass fibre	20	E20
Inorg. glass fibre and polymer (water absorption)	5	WA

4 Sealing Material

 NBR (Buna-N®) (standard) **B**
 FPM (Viton®) **V**
5 Quantity

 One piece filter element **1**
 Box with 12 pieces filter element **12**

Mini Water Vac ■ Type SMWV

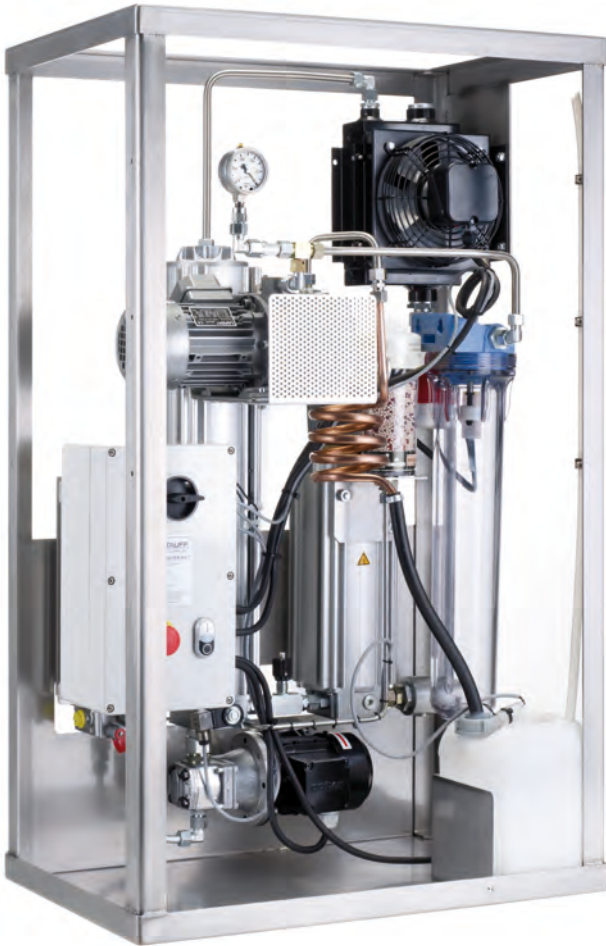

Product Description

The Mini Water Vac is a designated oil purification unit which can be applied directly to various types of machine reservoirs. It dehydrates and cleans most types of oils such as lubricating, hydraulic, transformer, and switch oils. The Mini Water Vac is a self-regulating filtration unit which removes particles, gas, and water. The purified oil satisfies the most stringent quality requirements.

The Mini Water Vac neither removes or alters oil additives. The water removal process is based on pure vacuum evaporation inside a vacuum chamber at a maximum temperature of +65 °C / +149 °F. Solid particle removal is achieved through a well proven STAUFF Systems Micro Filter.

Simple Operation

The Mini Water Vac does not require continuous supervision while operating. Once the unit is connected and commissioned, oil purification is a semi-automatic process. Desired oil temperature can be selected via the integrated heater thermostat. The dehydration and filtering process is fully automatic and is controlled via the PLC. The only manual action required is the emptying the pre-condenser bowl and the waste water container which are equipped with float switches to prevent overflow.

Water, Gas and Particle Removal

The Mini Water Vac removes liquid, gas, and solid particle contamination, which are corrosive and contribute to the reduction of machine life. Contamination greatly increases maintenance costs and contribute to breakdowns and total machine failures. The Mini Water Vac offers protection against malfunctions, breakdowns or total failures. The Mini Water Vac also protects the environment by reducing oil consumption and oil disposal.

Benefits

- Efficient water, gas and particle removal
- Extension of fluid life
- Reduces fluid disposal
- Minimizes corrosion
- Reduced failures and downtime
- Reduce operating costs

Technical Data

Construction

- SMWV-1A-30: Mini Water Vac Vacuum Dehydration Unit one filter housing

Materials

- Filter housing Anodized Aluminium
- Vacuum chamber Anodized Aluminium
- Heater chamber Anodized Aluminium

Port Connection

- Inlet G1
- Outlet G1/2
- Online particle counter STAUFF Test (M16x2)

Max. System Volume

- 3000 l / 795 gal

Recirculating Flow Rate

- 90 l/h / 23.8 gal/hr

Max. Backpressure

- 1 bar / 14.5 PSI

Max. Heater Temperature

- +65°C / +149°F

Filter Element

- 1 micron inorganic glass fibre element β₁ > 200

Media Compatibility

- Viscosity between 20 ... 500 cSt
- Max. attainable water content 100 ppm

Removals

- 100% of free water, >80% of dissolved water
- 100% of free gases, >80% of dissolved gases

Dimensions

- 1200 x 740 x 450 mm / 47.3 x 29.1 x 17.7 in

Weight

- 130 kg / 287 lbs

Electrical Data

- Voltage 230/400 V AC, 50 Hz
255/460 V AC, 50 Hz
- Power supply 3 phases
- Heater section 2 kW
- Vacuum section 0,037 kW vacuum pump
- Max. current 3 Amps

Process Control

- PLC unit

Mini Water Vac ■ Type SMWV

Dimensions SMWV-1A

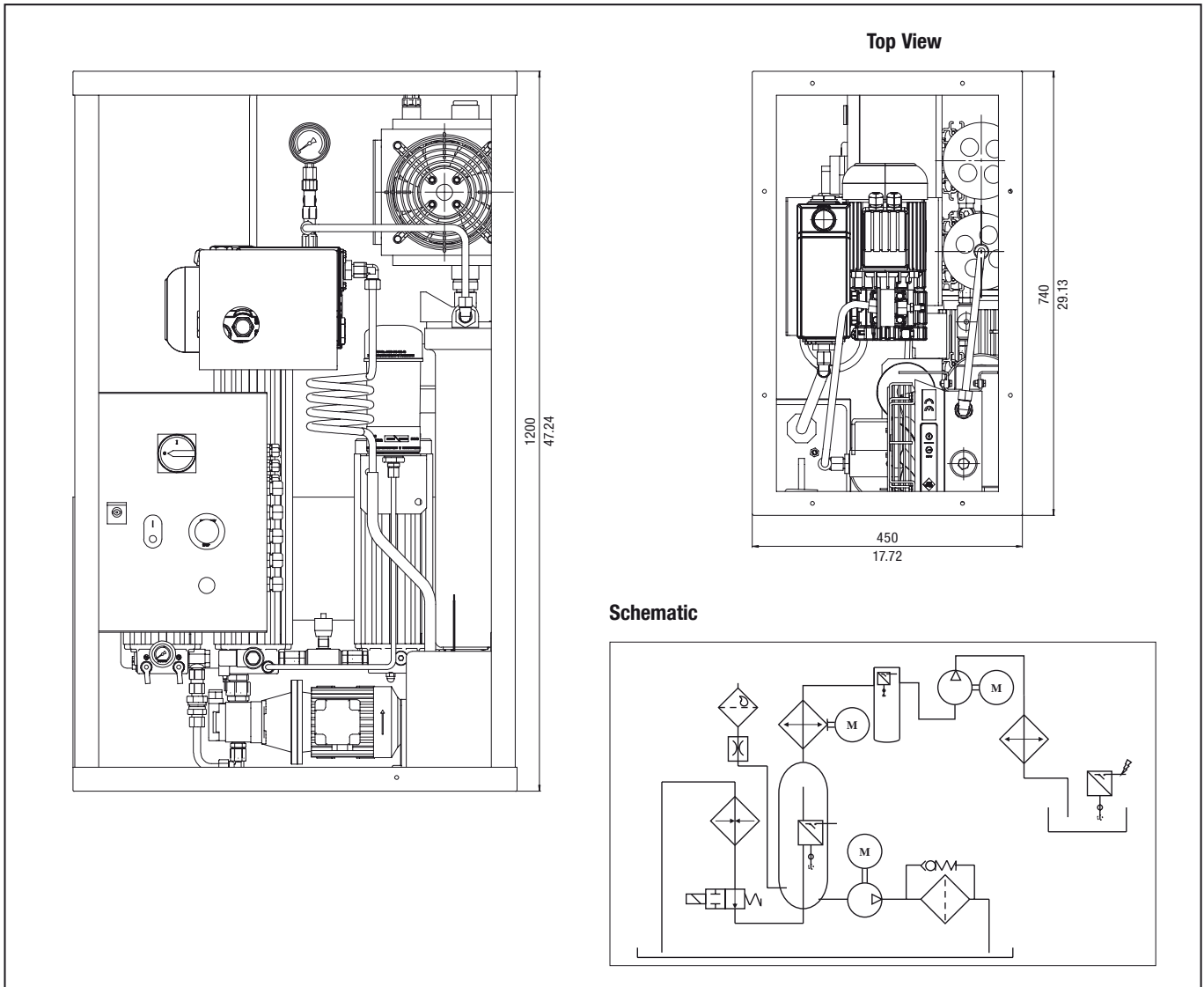

Mini Water Vac Filter Housings / Complete Filters ■ Type SMWV

All dimensions in mm / in

SMWV - 1A - 30 - H - B - B - 60 - 0 - 0 - 0

1 2 3 4 5 6 7 8 9 10

1 Type

 Mini Water Vac Oil Purifier (for industrial applications) **SMWV**
2 Housing Configuration

Length	Suitable for Reservoir Size	Quantity of Elements	Code
Single housing Single length	1350 l / 356 gal	1 pcs	1A

3 Filter Element Length

 300 mm / 11.81 in **30**
4 Filter Material and Micron Rating

Material	Micron Rating μm	Code
Cellulose (standard)	0,5	H
Inorg. glass fibre	1	E01
Inorg. glass fibre	3	E03
Inorg. glass fibre	5	E05
Inorg. glass fibre	10	E10
Inorg. glass fibre	20	E20
Inorg. glass fibre and polymer (water absorption)	5	WA

5 Sealing Material

NBR (Buna-N®)(standard)	B
FPM (Viton®)	V

6 E-motor Options

Type	Code
230/400 V AC, 50 Hz, three phases, 1360 r/min 255/460 V AC, 60 Hz, three phases, 1630 r/min	0

Note: Other motors on request, technical data see page C152.

7 Pump Options

 1 cc / rev **60**
8 Heating Element

 2000 Watt (standard) **0**
9 Extra Functions

 Without **0**
 With water sensor **1**
10 Options

 None **0**

Filter Elements ■ Type SRM



Product Description

STAUFF Systems distinguish themselves by their high efficiency filter elements which are capable of filtering silt particles down to 0,5 microns.

Two types of STAUFF Systems are available. The OLS Series uses an integral motor/pump combination to draw the hydraulic or lubrication fluid from the reservoir, filters it, and returns it to the reservoir. The other type of STAUFF System is the BPS Series which uses system pressure to draw a small oil flow from the system which is then filtered and returned to the reservoir.

The success of the STAUFF Off-Line Filtration System is due to the design of the element and housing. The element is constructed of 0,5 micron cellulose media applied with a special wrapping method, providing several hundred layers of filter media. The cellulose fibres also absorb and retain water, which slows down the oxidation process of the fluid. The construction of the housing allows only radial flow through the filter element. This design feature prevents channel forming and subsequent shortcircuiting of the media. The Off-Line design maintains a constant flow and pressure through the filter, which does not allow any particle unloading. These design characteristics enable the STAUFF Filtration System to maintain a rated filtration efficiency of $B_2 > 2330$. This allows the user to maintain fluid cleanliness levels which cannot be reached with conventional full flow filtration methods.

The unique STAUFF Filter

The principle of the STAUFF System is based on the unique original filter elements. With a filter fineness of 0,5 micron they have the capacity to remove even the smallest of dirt particles from the oil.

The micro filter works as a fine filter through which oil passes radially, from the outside to the inside. The filter elements are made entirely of cellulose and are specially designed for hydraulic and lubrication systems.

The use of cellulose as the filtration material has the added benefit that water can be absorbed. Water in oil creates a chemical reaction, which seriously deteriorates the oil.

Original Elements

The use of original STAUFF Systems filter elements will result in extreme fluid cleanliness and low water contamination levels in the fluid.

Through a carefully monitored quality control process excellent pressure drop curves, filter efficiency and dirt-hold capacity are ensured.

Cellulose Elements

The STAUFF Systems cellulose filter elements are unique in their design. They consist of several hundred layers of long fiber cellulose which are wound on a perforated center tube. The micro filter element works as a fine filter through which oil passes radially, from the outside to the inside, trapping solid particles throughout all the layers of cellulose.

The long fiber cellulose is also capable of absorbing water, adding the benefit of moisture removal from the oil. STAUFF Systems cellulose elements are extremely efficient and have a large dirt-hold capacity.

The cellulose elements are produced in various sizes to suit all STAUFF Systems filter housings. The STAUFF Systems cellulose elements compatible with most commonly used hydraulic and lubricating fluids, including biodegradable fluids.

Glass fibre Elements

STAUFF Systems offers a range of glass fibre filter elements in a fineness of 1, 3, 5, 10 or 20 micron. The micro filter element works as a fine filter through which oil passes radially, from the outside to the inside. STAUFF Systems glass fibre filter elements (conventional pleated construction) are extremely efficient and have a large dirt-hold capacity.

The glass fiber elements are suited for all STAUFF Systems filter housing (except the size 20 housing) and are compatible with most commonly used hydraulic and lubricating fluids, including biodegradable fluids. The glass fibre elements are particularly suited for gearbox applications where high viscosity fluids limit the use of the cellulose elements.

Water Sorb Filter Inserts

STAUFF Systems offers a specifically designed water sorb combination filter element: water absorbing and particle retention. This pleated filter element with a fineness of 5 micron has layers of polymers in between layers of glass fibre, creating a unique media to remove both water and solid particles from the fluid.

Characteristics

- Continuous quality with stable flow/ Δp performance
- Extremely fine filters (0.5 micron)
- Large filtration surface
- High water absorption capacity
- Additives are not removed
- Large dirt collection capacity
- Extends oil usage life
- Extends life cycle main stream filters

Applications

The original filter elements are used in combination with STAUFF Systems filter housings in an endless range of industries.

Some Examples are:

- Plastic industry
- Steel industry
- Concrete and cement industry
- Petrochemical industry
- Maritime industry
- Paper industry
- Forestry industry

Off-Line and Bypass Filters Replacement Elements - Type SRM

Filter Element Technical Data

Element Model	SRM-30HB	SRM-30E01B	SRM-30E03B	SRM-30WAB
Filter Material	Cellulose	Glass fibre	Glass fibre	Glass fibre and Polymer
Filtration Efficiency	$\beta_5 \geq 200 / \beta_2 \geq 2331$	$\beta_1 \geq 200$	$\beta_3 \geq 200$	$\beta_5 \geq 200$
Water Absorption Capacity	150 ml 5 oz	N/A	N/A	350 ml 11.8 oz
Nominal Flow per Element	2,1 l/min .6 GPM	2,1 l/min .6 GPM	2,1 l/min .6 GPM	2,1 l/min .6 GPM
Max. Viscosity at Nominal Flow Rate	180 cSt	800 cSt		
Max. Oil Temperature	+80 °C +176 °F			
Length of Element	300 mm 11.8 in			
Sealing Material (Standard)	NBR (Buna-N®) and Silicone Rubber	NBR (Buna-N®)	NBR (Buna-N®)	NBR (Buna-N®)
Other Sealing Material	Consult STAUFF			
Fluid Compatibility:				
--Mineral Oils				
H, HI, HLP, HVLP	OK	OK	OK	OK
-- Biodegradable Oils				
HEPG Polyethyleneglycol	Consult STAUFF			
HEES Synthetic ester	OK	OK	OK	OK
HETG Vegetable seed oil	Consult STAUFF			
-- Fire Inhibiting Fluids				
HFA emulsions	NO	OK	OK	NO
HFC glycol/water solution	NO	OK	OK	NO
HFD fluids no water content	Consult STAUFF			
Approximate Weight	0,8 kg 1.8 lb	1,25 kg 2.8 lb	1,25 kg 2.8 lb	1,25 kg 2.8 lb

 Filter Element SRM-30HB Δp / viscosity - graph

(at a flow of 2,1 l/min / .6 US GPM per element)

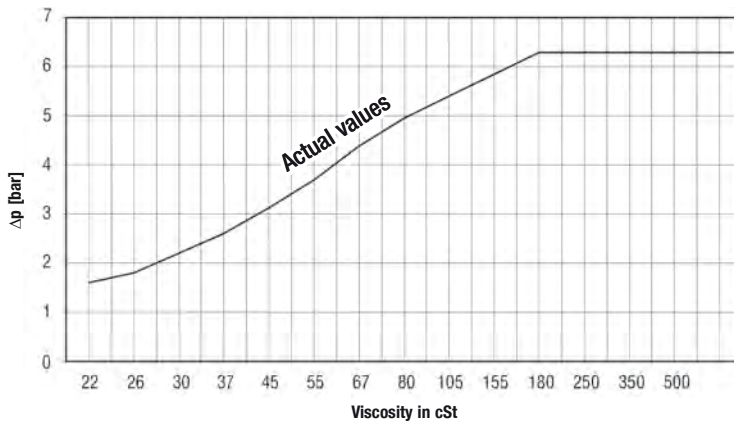
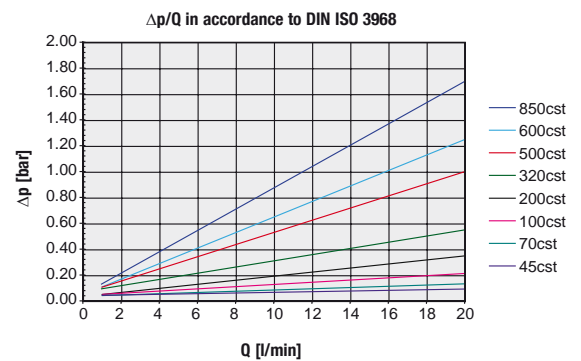
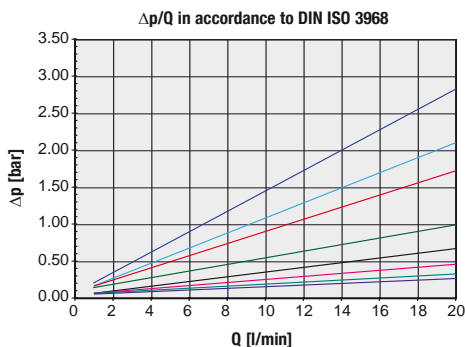
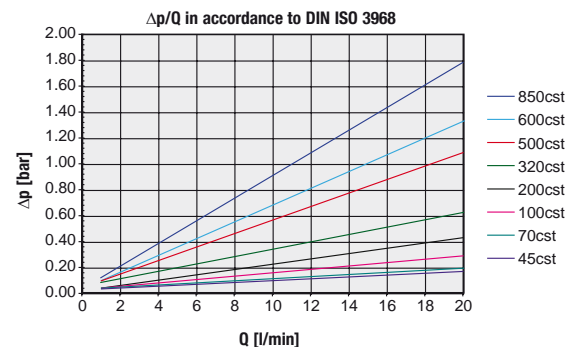
 Filter Element SRM-30E03B Δp / Viscosity-Graph

 Filter Element SRM-30E01B Δp / Viscosity-Graph

 Filter Element SRM-30WAB Δp / Viscosity-Graph

STAUFF Mobile Filter Units



Product Description

Mobile Filtration Systems from STAUFF already covered a wide spectrum of use: On the one hand compact and versatile, on the other hand designed for long-lasting use and highest nominal flow rates, they support the preventive maintenance of hydraulic and lubrication systems, thus providing extended maintenance intervals and helping to reduce operating costs within shortest payback periods. To cover region specific requirements STAUFF has a large range of different Mobile Filtration Systems.

STAUFF Europe: STAUFF Mobile Filter Unit SMFS-P-015



- High-quality gear pump
- Nominal flow rate up to 15 l/min / 4 US GPM
- 2 motor versions: 230 V 50 Hz or 400 V 50 Hz
- Micron rating available from 3 ... 125 µm
- Hand-held unit
- Weight: approx. 23 kg / 51 lbs

STAUFF America: STAUFF Portable Filter Cart SCFC-05 / 10



- High-quality gear pump
- Nominal flow rate up to 38 l/min / 10 US GPM
- 3 motor versions: 110 V / 230 V / 400 V
- Micron rating available from 3 ... 125 µm
- Weight: approx. 53 kg / 117 lbs

STAUFF Europe: STAUFF Mobile Filter Unit SMFS-U-030



- High-quality gear pump
- Nominal flow rate up to 30 l/min / 8 US GPM
- 2 motor versions: 230 V 50 Hz or 400 V 50 Hz
- Micron rating available from 3 ... 125 µm
- Weight: approx. 46 kg / 101 lbs

STAUFF America: STAUFF Portable Filter Cart SPFC-10



- High-quality gear pump
- Nominal flow rate up to 38 l/min / 10 US GPM
- 3 motor versions: 110 V / 230 V / 400 V
- Micron rating available from 3 ... 125 µm
- Weight: approx. 86 kg / 189 lbs

STAUFF Europe: STAUFF Mobile Filter Unit SMFS-U-060 / 110



- High-quality gear pump
- Nominal flow rate up to 60 l/min / 15 US GPM or 110 l/min / 30 US GPM
- Micron rating available from 3 ... 25 µm
- Weight: approx. 87 kg / 192 lbs

STAUFF Australia: STAUFF Portable Filter Cart SPFC



- High-quality gear pump
- Nominal flow rate up to 23 l/min / 6 US GPM
- Magnetic core pre-filtration
- Micron rating 10 µm
- Weight: approx. 53 kg / 117 lbs

