

PowerMaster III  
Pneumatic barrel pump consisting of  
air motor, pump tube and pump hoist

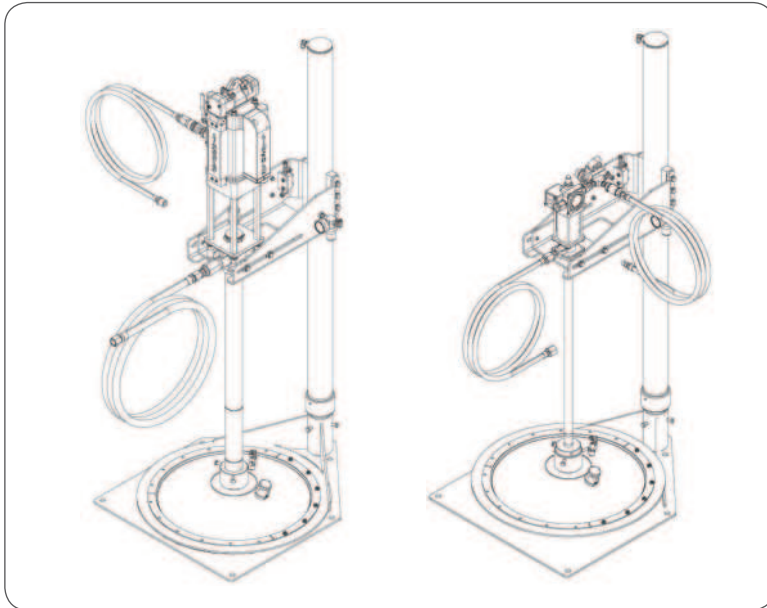

Version 02

## EC Declaration of conformity following machinery directive 2006/42/EC, annex II Part 1 A

The manufacturer

Lincoln Industrial, One Lincoln Way, St. Louis, MO 63120-1578 USA

hereby declares under sole responsibility that the product described in these instructions

Designation: Barrel pump to supply lubricant of the specification given in these instructions.

Type: PowerMaster III

Part no.: 274680 / 274681

Year of construction: see type identification plate

consisting of the following combination of incomplete machines

1. PowerMaster III air motor Part no's 84803, 84804, 84806, 84808, 86810
2. PowerMaster III pump tube Part no's 84991 - 84998, 84976 - 84987, 85201, 85202 oder
2. PileDriver III Pumpe tube Part no's 84800 - 84904, 84921 - 84923
4. Pump hoist Part no's 2710, 2740

complies with all basic requirements of the following directives at the time when first being launched in the market.

Machinery directive: 2006/42/EC

RoHS II 2011/65/EC

Applied and harmonized standards

DIN EN ISO 12100:2011; DIN EN 809-1: 2011

In the case of modifications or alterations of the above mentioned machine not authorized by the manufacturer validity of this EC declaration of conformity will cease. The person empowered to assemble the technical documentation on behalf of the manufacturer is the head of standardization; see manufacturer's address.

Manufacturer

Lincoln Industrial, One Lincoln Way  
St. Louis, MO 63120-1578 USA

EU Representative

SKF Lubrication Systems Germany GmbH

Werk Walldorf

Heinrich-Hertz-Str. 2-8

DE - 69190 Walldorf

Date: 15.01.2014

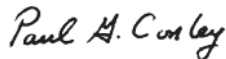

Paul G. Conley  
Chief Engineer

## Legal Disclosure

The original operating instructions following machinery directive 2006/42/EC are part of the described products and must be kept at an accessible location for further use.

### Warranty

The instructions do not contain any information on the warranty. This can be found in the general terms and conditions.

### Copyright

© SKF. All rights reserved.

### Manufacturer

Lincoln Industrial, One Lincoln Way  
St. Louis, MO 63120-1578 USA  
Tel: +1.314.679.4200  
Fax: +1.800.424.5359  
E-mail: [lincoln@lincolnindustrial.com](mailto:lincoln@lincolnindustrial.com)  
[www.lincolnindustrial.com](http://www.lincolnindustrial.com)  
[www.skf.com/lubrication](http://www.skf.com/lubrication)

### Sales and Service Regions

Americas / Asia / Pacific

### EU Representative

SKF Lubrication Systems Germany GmbH  
Werk Walldorf  
Heinrich-Hertz-Str. 2-8  
DE - 69190 Walldorf  
E-mail: [Lubrication-germany@skf.com](mailto:Lubrication-germany@skf.com)  
[www.skf.com/lubrication](http://www.skf.com/lubrication)

### Sales and Service Regions

Europe / Africa / Middle East / India

# Table of contents





Original operating instructions	1	<b>2. Lubricants</b>	14	4.5 Pressure ratios of PowerMaster III air motors and PileDriver III pump tubes	23
EC Declaration of conformity	2	2.1 General information	14	4.6 Compressed air quality	24
Explanation of symbols and signs	6	2.2 Selection of lubricants	14	4.7 Tightening torques	24
		2.3 Approved lubricants	15	4.8 Material compatibility	24
		2.4 Lubricants and the environment	16		
		2.5 Lubricant hazards	16		
<b>1. Safety instructions</b>	<b>8</b>	<b>3. Overview/ functional description</b>	<b>17</b>	<b>5. Delivery, returns and storage</b>	<b>25</b>
1.1 General safety instructions	8	3.1 Short description	18	5.1 Delivery	25
1.2 General behaviour when handling the product	8	3.2 Operating and control elements	19	5.2 Returns	25
1.3 Qualified technical personnel	9			5.3 General notes related to the storage	25
1.4 Electric shock hazard	10	<b>4. Technical data</b>	<b>20</b>	5.4 Storage	25
1.5 System pressure hazard	10	4.1 Technical data PowerMaster III air motors	20	<b>6. Assembly</b>	<b>26</b>
1.6 Operation	10	4.2 Technical data PowerMaster III and PileDriver III pump tubes	21	6.1 General information	26
1.7 Assembly, maintenance, malfunctions, shutdown, disposal	11	4.3 Possible combinations of PowerMaster III air motors and PowerMaster III pump tubes	22	6.2 Set-up and attachment	26
1.8 Intended use	12	4.4 Pressure ratios of PowerMaster III air motors and PowerMaster III pump tubes	23	6.3 Assembly dimensions	27
1.9 Foreseeable misuse	12			6.4 Installation of the threaded rods	28
1.10 Disclaimer of liability	12			6.5 Installation of the quick air coupling	28
1.11 Referenced documents	12			6.6 Connection of air motor and pump tube	29
1.12 Residual risks	13			6.7 Installation of the protective cover	30
				6.8 Compressed air connection	30

<b>7. Start-up/ operation</b>	<b>31</b>	<b>11. Spare parts</b>	<b>37</b>	<b>12. Accessories</b>	<b>42</b>
7.1 General information	31	11.1 Pilot block assembly	37	12.1 Specific safety instructions for air operated pump hoists	42
7.2 Adjustment of the correct air pressure	31	11.2 Sound absorber assembly	37	12.2 Technical data of pump hoist	43
<b>8. Shutdown and disposal</b>	<b>32</b>	11.3 Control slide subassembly PowerMaster III air motor	37	12.3 Operating and control elements of pump hoist	44
8.1 Temporary shutdown	32	11.4 Control slide subassembly housing with valve piston	38	12.4 Installation of pump hoist	45
8.2 Final shutdown and disposal	32	11.5 Pilot block subassembly Pneumatic relay valve	38	12.5 Installation of barrel	46
<b>9. Maintenance</b>	<b>33</b>	11.6 Pilot block subassembly Pneumatic signal valve	38	12.6 Remove barrel	46
9.1 General information	33	11.7 Cover hood for PowerMaster III air motor	38	12.7 Spare parts of pump hoist	47
9.2 Cleaning	33	11.8 Set of seals for drive cylinder	38		
9.3 Maintenance	33	11.9 Spare parts for PowerMaster III air motors	39		
9.4 Required tools	33				
9.5 Maintenance of the pilot block	33				
9.6 Maintenance of the sound absorber	34				
9.7 Maintenance of the control valve	34				
9.8 Maintenance of the drive cylinder	34				
9.9 Test run	35				
<b>10. Troubleshooting</b>	<b>36</b>				

## Explanation of symbols and signs

You will find these symbols, which warn of specific dangers to persons, material assets, or the environment, next to all safety instructions in these operating instructions.

Please heed these instructions and proceed with special care in such cases. Please forward all safety instructions to other users.

	Warning level	Consequences	Probability
	<b>DANGER</b>	Death/ serious injury	Immediate
	<b>WARNING</b>	Serious injury	Possible
	<b>CAUTION</b>	Minor injury	Possible
	<b>ATTENTION</b>	Property damage	Possible

Symbols	
Symbol	Meaning
●	Prompts an action
○	Used for itemizing
	Refers to other facts, causes, or consequences
→	Provides additional information within procedures

Symbols used	
Symbol	Meaning
	General warning
	Electrical component hazard Electrical shock hazard
	Slipping hazard
	Hazard from hot surfaces
	Crushing hazard
	Pressure injection hazard
	Wear personal protective equipment (hearing protection)
	Wear personal protective equipment (goggles)
	Wear protective gloves
	Note
	Environmentally sound disposal

Abbreviations and conversion factors

**Abbreviations**

re.	regarding	oz.	Ounce
approx.	approximately	psi	pounds per square inch
°C	degrees Celsius	rh	relative humidity
cu.in	cubic inch	s	second
dB (A)	sound pressure level	sq.in.	square inch
i.e.	that is	e.g.	for example
etc.	et cetera	>	greater than
poss..	possibly	<	less than
°F	degrees Fahrenheit	±	plus or minus
fl.ou	fluid ounce	∅	diameter
fpsec	feed per second	mph	miles per hour
gal.	Gagallon	assy.	assembly

hp	horse power
in.	inch
incl.	including
K	Kelvin
kg	kilogram
kp	kilopond
kW	kilowatt
l	litre
lb.	pound
max.	maximum
min.	minimum
Min.	minute
ml	millilitre
ml/d	millilitre per day
mm	millimeter
N	Newton
Nm	Newtonmeter

**Conversion factors**

Length	1 mm = 0.03937 in.
Area	1 cm <sup>2</sup> = 0.155 sq.in
Volume	1 ml = 0.0352 fl.oz.
	1 l = 2.11416 pints (US)
Mass	1 kg = 2.205 lbs
	1 g = 0.03527 oz.
Density	1 kg/cm <sup>3</sup> = 8.3454 lb./gal(US)
	1 kg/cm <sup>3</sup> = 0.03613 lb./cu.in.
Force	1 N = 0.10197 kp
Speed	1 m/s = 3.28084 fpsec.
	1 m/s = 2.23694 mph
	1 m/s <sup>2</sup> = 3.28084 ft./s <sup>2</sup>
Acceleration	
Pressure	1 bar = 14.5 psi
Temperature	°C = (°F-32) x 5/9
Power	1 kW = 1.34109 hp

## 1. Safety instructions

### 1.1 General safety instructions

The operator must ensure that the lifecycle manual is read and understood by all persons tasked with working on the product or who supervise or instruct such persons. The operator must also ensure that the staff fully understands the content of the lifecycle manual.

The described product was manufactured according to the state of the art. Risks may, however, arise from its usage and may result in harm to persons or damage to material assets.

Any malfunctions which may affect safety must be remedied immediately. In addition to the lifecycle manual, general statutory regulations and other regulations for accident prevention and environmental protection must be observed and applied.

### 1.2 General behaviour when handling the product

- The product may only be used in awareness of the potential dangers, in proper technical condition, and according to the information in these instructions.
  - Technical personnel must familiarize themselves with the functions and operation of the product. The specified assembly and operating steps and their sequences must be observed.
  - Any unclear points regarding proper condition or correct assembly/ operation must be clarified. Operation is prohibited until issues have been clarified.
  - Unauthorized persons must be kept away from the product.
  - All safety regulations and in-house instructions relevant to the particular task must be observed.
  - Responsibilities for different activities must be clearly defined and observed. Uncertainty seriously endangers safety.
- Protective and safety mechanisms cannot be removed, modified, or disabled during operation and must be checked for proper function and completeness at regular intervals.
  - If protective and safety mechanisms must be removed, they must be installed immediately following conclusion of work and then checked for proper function.
  - Any malfunctions that occur must be resolved according to responsibility. The operator of the system/ machine must be notified in case of malfunctions outside the scope of responsibility.
  - Wear personal protective equipment.
  - Observe the particular safety data sheets (MSDS) when handling the materials to be supplied.

## 1. Safety instructions

---

### 1.3 Qualified technical personal

Only qualified technical personnel may install, operate, maintain, and repair the products described in this document.

Qualified technical personnel are persons who have been trained, assigned, and instructed by the operator of the final product into which the described product is incorporated.

Such persons are familiar with the relevant standards, rules, accident prevention regulations, and assembly conditions as a result of their training, experience, and instruction. They are qualified to carry out the required activities and in doing so recognize and avoid any potential hazards.

The definition of qualified personnel and the prohibition against employing non-qualified personnel are laid down in DIN VDE 0105 and IEC 364.



Relevant country-specific definitions of qualified technical personnel apply for countries outside the scope of DIN VDE 0105 or IEC 364.

The core principles of these country-specific qualification requirements for technical personnel cannot be below those of the two standards mentioned above.

The operator of the final product is responsible for assigning tasks and areas of responsibility and for the responsibility and monitoring of the personnel. These areas must be precisely specified by the operator. The personnel must be trained and instructed if they do not possess the requisite knowledge.



Product training can also be performed by SKF in exchange for costs incurred.

## 1.4 Electrical shock hazard

		<b>WARNING</b>
	<p><b>Electric shock</b> Performing work on products that have not been de-energized may result in serious injury or death. Assembly, maintenance, and repair work may only be performed on products that have been de-energized by qualified technical personnel.</p>	

Electrical connections for the described product may only be established by qualified and trained personnel authorized to do so by the operator, and in observance of the local conditions for connections and local regulations (e.g. VDE/ IEC). Serious injury or death and property damage may result from improperly connected products.

## 1.5 System pressure hazard

		<b>WARNING</b>
	<p><b>System pressure</b> The product is pressurized during operation. Centralized lubrication systems must therefore be depressurized before starting assembly, maintenance, or repair work, or any system modifications or system repairs.</p>	

## 1.6 Operation

The following must be observed during commissioning and operation.

- All information within this manual and the information within the referenced documents.
- All laws/ regulations that the operator must observe.

## 1. Safety instructions

---

### 1.7 Assembly, maintenance, malfunctions, shutdown, disposal

- All relevant persons (e.g., operating personnel, supervisors) must be informed of the activity prior to the start of work. Precautionary operational measures/ work instructions must be observed.
- Ensure through suitable measures that moving/ detached parts are immobilized during the work and that no body parts can be pinched by unintended movements.
- Assemble the product only outside the operating range of moving parts, at an adequate distance from sources of heat or cold.
- Prior to performing work, the product and the machine/ system in which the product is or will be integrated must be depressurized and secured against unauthorized activation.
- All work on electrical components may be performed only with voltage-insulated tools.
- Fuses must not be bridged. Always replace fuses with fuses of the same type
- Ensure proper grounding of the product.
- Drill required holes only on non-critical, non-load bearing parts.
- Other units of the machine/the vehicle must not be damaged or impaired in their function by the installation of the centralized lubrication system.
- No parts of the centralized lubrication device may be subjected to torsion, shear, or bending.
- Use suitable lifting gear when working with heavy parts.
- Avoid mixing up/ incorrect assembling of disassembled parts. Label parts accordingly.

### 1.8 Intended use

Supply of lubrication greases and oils following the specifications made in chapter 'Technical data'. A use is allowed only in the interior and by commercial operators familiar with the country-specific operational health and safety measures. Other transportable materials on request.

### 1.9 Foreseeable misuse

A usage of the product differing from the aforementioned conditions and stated purpose is strictly prohibited. Particularly prohibited are:

- Use in an explosive atmosphere.
- Operation of the air motor with other media than the specified compressed air.
- The supply of flammable or toxic substances.
- Use to feed, forward or store Group 1 dangerous fluids according to Directive 67/548/EC.
- Use to feed, forward or store gases, liquefied gases, dissolved gases, vapors, or

fluids whose vapor pressure exceeds normal atmospheric pressure (1013mbar) by more than 0.5 bar at their maximum permissible temperature.

- Use of the Power Master III air motor 86810 with Power Master III pump tube.
- Operation with protective cover.

#### 1.10 Disclaimer of liability

The manufacturer shall not be held responsible for damages:

- caused by contaminated or unsuitable materials to be supplied.
- caused by contaminated or unsuitable compressed air.
- caused by the installation of non-original SKF components or SKF parts.
- caused by in appropriate usage.
- Resulting from improper assembly, configuration, or filling.
- Resulting from improper response to malfunctions.
- Caused by unauthorized modification of system components.

### 1.11 Referenced documents

In addition to these instructions, the following documents must be observed by the respective target group:

- Operational instructions and approval rules
- Instructions from suppliers of purchased parts
- Safety data sheet (MSDS) of the material to be supplied.
- Operating instructions of the air maintenance unit.
- Operating instructions of the pump hoist to be used.
- Project planning documents and other relevant documents, if provided.

The operator must supplement these documents with applicable national regulations for the country of use. This documentation must be included, if the product/ machine is sold or transferred.

## 1.12 Residual risks

Residual risk	Remedy
Life cycle assembly, start-up, operation, malfunction, troubleshooting, repair, maintenance, shutdown, disposal	
Electric shock due to defective connection cable	<ul style="list-style-type: none"> <li>• Check connection cable for damages</li> </ul>
People slipping due to floor contamination with spilled/ leaking lubricant	<ul style="list-style-type: none"> <li>• Exercise caution when connecting the ink connections</li> <li>• Promptly apply suitable binding agents and remove leaking/ spilled ink</li> <li>• Follow operational instructions for handling UV inks and piston lubricants and contaminated parts</li> </ul>
UV ink/ piston lubricant spraying out due to faulty component fitting / line connection	<ul style="list-style-type: none"> <li>• Tighten all components securely or using the specific torques. Use hydraulic connections and lines suitable for the indicated pressures. These must be checked for proper connection and for damage prior to commissioning</li> </ul>
Injury caused by compressed air	<ul style="list-style-type: none"> <li>• Before any works on the UV ink pump, depressurize pump and secure against accidental starting</li> </ul>
During all works with UV ink and piston lubricant make sure to wear personal professional equipment (protective glasses, protective gloves).	

## 2. Lubricants

### 2.1 General information

#### ATTENTION

All products may be used only for their intended purpose and in accordance with the lifecycle instructions.

Intended use is the use of the products for the purpose of providing centralized lubrication/ lubrication of bearings and friction points with lubricants within the physical usage limits which can be found in the documentation for the device, e.g., operating instructions and the product descriptions, e.g. technical drawings and catalogs. Particular attention is called to the fact that hazardous materials of any kind, especially those materials classified as hazardous by EC Directive 67/548/EEC, Article 2, Para. 2, may only be filled into Lincoln centralized lubrication systems and components and delivered and/ or distributed with such systems and components after consulting with and obtaining written approval from Lincoln.

No products manufactured by Lincoln are approved for use in conjunction with gases, liquefied gases, pressurized gases in solution, vapors, or such fluids whose vapor pressure exceeds normal atmospheric pressure (1013 mbar) by more than 0.5 bar at their maximum permissible temperature.

Other media which are neither lubricant nor hazardous substance may only be fed after consultation with and written approval from Lincoln.

SKF considers lubricants to be an element of system design and must always be factored into the selection of components and the design of centralized lubrication systems.

The lubricating properties of the lubricants are critical.

### 2.2 Selection of lubricants

#### ATTENTION

Observe the instructions from the machine manufacturer regarding the lubricants that are to be used. The amount of lubricant required at the lube point is specified by the bearing or machine manufacturer. It must be ensured that the required lubricant volume is provided to the lubrication point. The lubrication point may otherwise not receive adequate lubrication, which can lead to damage and failure of the bearing.

Selection of a lubricant suitable for the lubrication task is made by the machine/ system manufacturer and/or the operator of the machine/ system in cooperation with the lubricant supplier.

When selecting a lubricant, the type of bearings or friction points, the expected load during operation, and the anticipated ambient conditions must be taken into account. All economic and environmental aspects must also be considered.

### 2.3 Approved lubricants

#### ATTENTION

If required SKF can help customers to select suitable components for feeding the selected lubricant and to plan and design their centralized lubrication system.

Please contact SKF if you have further questions regarding lubricants. It is possible for lubricants to be tested in the company's laboratory for their suitability for pumping in centralized lubrication systems (e.g. „bleeding“). You can request an overview of the lubricant tests offered by SKF from the company's service department.

#### ATTENTION

Only lubricants approved for the product may be used. Unsuitable lubricants can lead to failure of the product and to property damage.

#### ATTENTION

Different lubricants must not be mixed. Doing so can cause damage and require costly and complicated cleaning of the product/ lubrication system. It is recommended that an indication of the lubricant in use be attached to the lubricant reservoir in order to prevent accidental mixing of lubricants.

The product described here can be operated using lubricants that meet the specifications in the technical data. Depending on the product design, these lubricants may be oils, fluid greases, or greases.

Mineral, synthetic, and/ or and rapidly biodegradable oils and base oils can be used. Consistency agents and additives may be added depending on the operating conditions.

Note that in rare cases there may be lubricants whose properties are within permissible limit values but whose other characteristics render them unsuitable for use in centralized lubrication systems. For example, synthetic lubricants may be incompatible with elastomers.

## 2.4 Lubricants and the environment





### ATTENTION

Lubricants may pollute ground and waters. Lubricants have to be handled and disposed of properly. Relevant applicable regulations and laws regarding the disposal of lubricants must be observed.

It is important to note that lubricants are environmentally hazardous, flammable substances which require special precautionary measures during transport, storage, and processing. Consult the safety data sheet from the lubricant manufacturer for information regarding transport, storage, processing, and environmental hazards of the lubricant that will be used.

The safety data sheet for a lubricant can be requested from the lubricant manufacturer.

## 2.5 Lubricant hazards

	<table border="1"> <tr> <td data-bbox="662 275 727 345">  </td> <td data-bbox="727 275 1010 345"> <b>WARNING</b> </td> </tr> <tr> <td colspan="2" data-bbox="662 345 1010 559"> <p>Risk of slipping and injury Leaking lubricant represents a potential source of danger. Leaks must be sealed off without delay.</p> </td> </tr> </table>		<b>WARNING</b>	<p>Risk of slipping and injury Leaking lubricant represents a potential source of danger. Leaks must be sealed off without delay.</p>	
	<b>WARNING</b>				
<p>Risk of slipping and injury Leaking lubricant represents a potential source of danger. Leaks must be sealed off without delay.</p>					

### 3. Overview/ functional description

Item	Description
1	PowerMaster III air motor
2	AirBrake switch-off modul (option)
3	Protective cover with cover plate
4	PowerMaster III pump tube or PileDriver III pump tube
5	Pump hoist (option)

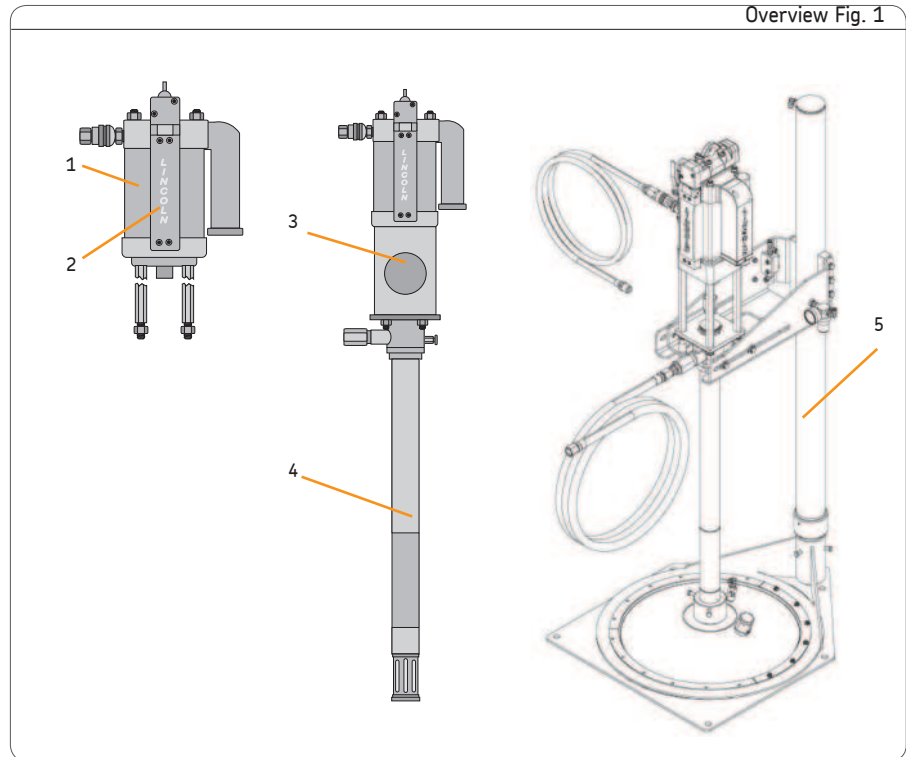

2

3

### 3.1 Short description

PowerMaster III pumps are compact powerful, pneumatically driven pumps to supply lubrication greases and oils as specified in chapter 'Technical data'.

To supply lubricant the supply piston inside the pump tube carries out up- and downward movements.

In combination with the Lincoln pump hoist (5) and a follower plate (6) the PowerMaster III pump can be driven also as a barrel pump. In this case the follower plate is seated on the surface of the material to be supplied and lowers down into the round or rectangular container while being emptied. When reaching the adjusted minimum filling height (low-level indication) the PowerMaster III pump is switched off.

Overview Fig. 2

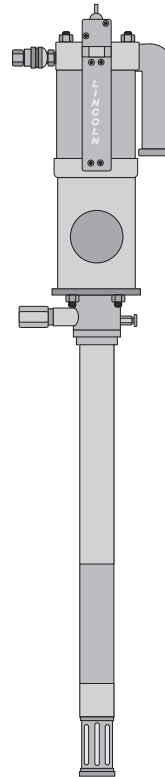

Overview Fig. 3

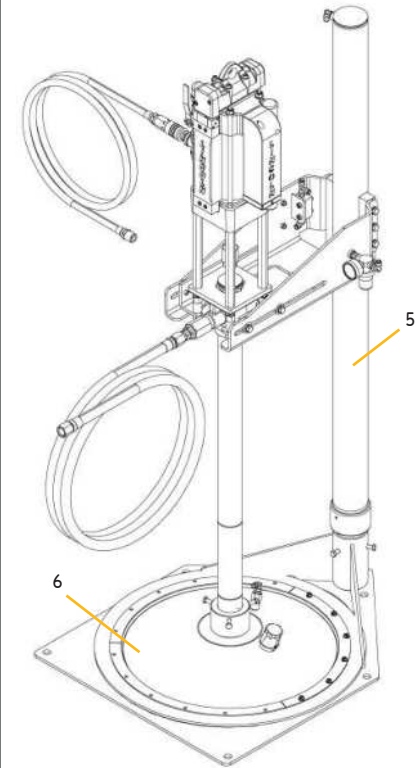

### 3.2 Operating and control elements

#### 7 Air pressure connection

For pneumatical connection of the Power-Master III air motor via a corresponding maintenance unit to the compressed air supply of the operator.

#### 2 AirBrake modul (option)

The AirBrake modul prevents the air motor from running too fast (e.g. when there is no material to be supplied). If the air motor runs to fast, the AirBrake modul will switch the air motor off.

#### 3 Protective cover with cover plate (without Fig.)

Covers the area of connection of the air motor and the pump tube. The protective cover consists of two parts, each provided with an inspection port covered by a cover plate (no Fig.). The cover plate can be removed by means of a screw driver. The inspection ports serve to control the sealing of the gland. In case of the pump tubes with lube cup they serve to control the filling level and

to refill the system.

#### 8 Pumpe tube connection

Connection of the pump tube (supply piston) to the pneumatic drive piston of the air motor.

#### 9 Connection for material to be supplied

Serves to connect the tube line of the material to be supplied.

#### 11 Vent valve

Serves to remove air inclusions in the pump tube.

#### 12 Suction bore

Serves to take in the material to be supplied. During operation the suction bore is immersed in the material to be supplied.

Overview Fig. 3

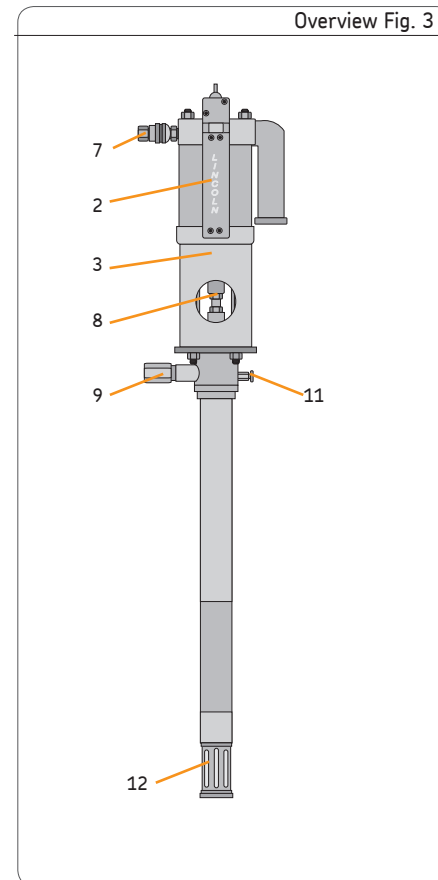

## 4. Technical data

### 4.1 Technical data of the PowerMaster III air motor

Air motor	84803	84804	84806	84808	84810
Air motor with AirBrake™	<del>84803</del>	94804	94806	94808	94810
Operating temperature	min -34 °C		max. + 93 °C		
Operating pressure	min. 02 bar max. 14 bar	min. 02 bar max. 14 bar	min. 02 bar max. 07 bar	min. 02 bar max. 07 bar	min. 02 bar max. 07 bar
Air consumption (l/min <sup>-1</sup> )	1400	2240	3220	5250	7210
Air pressure of quick coupling	1/2" NPTF	1/2" NPTF	3/4" NPTF	3/4" NPTF	3/4" NPTF
Min. Ø compressed air line	10 mm	12 mm	12 mm	20 mm	20 mm
Max. double strokes per minute	70 min <sup>-1</sup>				
Length of stroke	152 mm				
Cylinder diameter	76 mm	108 mm	152 mm	203 mm	254 mm
Dimensions mm (BxTxH)	191x152x600	191x152x600	235x197x578	286x243x578	337x295x578
Sound pressure level	< 85 dB (A)				
Weight of air motor	11.3 kg	11.7 kg	15.5 kg	21.2 kg	28.1 kg

## 4.2 Technical data of the PowerMaster III and PileDriver III pump tubes

Pump tube	Length <sup>1</sup>	Output <sup>2</sup>	Material <sup>3</sup>	Version <sup>4</sup>	Pump tube	Length <sup>1</sup>	Output <sup>2</sup>	Material <sup>3</sup>	Version <sup>4</sup>
PowerMaster III pump tubes									
84991	864	100	G	a	84976	864	110	S	b
84992	695	100	G	a	84977	695	110	S	b
84993	864	61	G	a	84978	864	75	S	b
84994	695	61	G	a	84979	695	75	S	b
84995	864	49	G	a	84981	864	195	O	c
84996	695	49	G	a	84982	864	195	O	c
84997	864	34	G	a	84983	864	195	O	c
84998	695	34	G	a	84984	695	195	O	c
85201	864	21	G	a	84985	864	195	O	c
85202	695	21	G	a	84986	232	195	O	d
					84987	232	195	O	d
PileDriver III pump tubes									
84900	436	360	G	a	84904	436	295	O	e
84901	436	278	G	a	84922	505	754	O	e
84902	436	196	G	a	84923	505	1393	O	e
84921	505	721	G	a					
<p>Legend</p> <p>1 = Length of immersion tube in mm / 2 = Output in ccm per double stroke</p> <p>3 = Transportable material G = grease / O = oil / S = greases and special materials (e.g. inks, abrasive materials, etc.) (special material only after previous approval/verification by the pump manufacturer)</p> <p>4 = Versions a = shovel foot with plunger-in-bushing style piston / b = shovel foot with packed pistons c = ball-style foot valve / d = ball-style foot valve (short version) / e = flat check foot valve</p>									

#### 4.3 Possible combinations of PowerMaster III air motors and PowerMaster III pump tubes

Air motor \ Pump tube	84803	84804	84806	84808
84991	✓	✓	✓	✓
84992	✓	✓	✓	✓
84993	✓	✓	✓	
84994	✓	✓	✓	
84995	✓	✓		
84996	✓	✓		
84997	✓	✓		
84998	✓	✓		
85201	✓			
85202	✓			

Air motor \ Pump tube	84803	84804	84806	84808
84976	✓	✓	✓	✓
84977	✓	✓	✓	
84978	✓	✓	✓	
84979	✓	✓	✓	
84981	✓	✓	✓	✓
84982	✓	✓	✓	✓
84983	✓	✓	✓	✓
84984	✓	✓	✓	✓
84985	✓	✓	✓	✓
84986	✓	✓	✓	✓
84987	✓	✓	✓	✓

- Note: PileDriver III pump tubes can be combined with all PowerMaster III air motors.

## 4.4 Pressure ratios of PowerMaster III air motor and PowerMaster III pump tubes

Air motor \ Pump tube	84803	84804	84806	84808	
	Ratio (i)				
84991	12:1	24:1	48:1	84:1	
84992	12:1	24:1	48:1	84:1	
84993	20:1	40:1	80:1		
84994	20:1	40:1	80:1		
84995	24:1	50:1			
84996	24:1	50:1			
84997	36:1	75:1			
84998	36:1	75:1			
85201	50:1				
85202	50:1				

Air motor \ Pump tube	84803	84804	84806	84808	
	Ratio (i)				
84976	10:1	22:1	44:1	80:1	
84977	10:1	22:1	44:1	80:1	
84978	15:1	32:1	64:1		
84979	15:1	32:1	64:1		
84981	6:1	12:1	24:1	42:1	
84982	6:1	12:1	24:1	42:1	
84983	6:1	12:1	24:1	42:1	
84984	6:1	12:1	24:1	42:1	
84985	6:1	12:1	24:1	42:1	
84986	6:1	12:1	24:1	42:1	
84987	6:1	12:1	24:1	42:1	

## 4.5 Pressure ratios of PowerMaster III air motor and PileDriver III pump tubes

Air motor \ Pump tube	84803	84804	84806	84808	86810
	Ratio (i)				
84900	3:1	7:1	15:1	25:1	42:1
84901	4:1	10:1	20:1	35:1	55:1
84902	6:1	12:1	25:1	45:1	75:1
84921	1,5:1	3:1	7:1	13:1	20:1

Air motor \ Pump tube	84803	84804	84806	84808	86810
84904	4:1	8:1	18:1	30:1	45:1
84922	1,5:1	3:1	7:1	13:1	20:1
84923	1:1	1,5:1	3:1	6:1	10:1

#### 4.6 Compressed air quality

The compressed air must comply with min. quality class 5 following DIN ISO 8573-1:

- max. particle size/ particle density
- 40  $\mu\text{m}$  / 10  $\text{mg}/\text{m}^3$
- pressure dew point 7°C
- water content max. 7.800  $\text{mg}/\text{m}^3$
- residual oil content max. 25  $\text{mg}/\text{m}^3$

The pneumatic connection may be realized only via an air pressure regulator with pressure gauge and shut-off valve or via a corresponding maintenance unit. We recommend to realize the connection via a maintenance unit. The size of the air pressure regulator/ the maintenance unit depends on the size of the air quick coupling on the air motor (1/2" or 3/4").

If the inlet air pressure is greater than the maximum operating pressure of the pump, there must be provided an air pressure reducer with safety valve additionally.

#### 4.7 Tightening torques

In the following please find the tightening torques to be adhered to. The item numbers serve to identify the parts (see spare part drawings).  
(Item 5.1)

Tightening torque = 156-170 Nm

(Item 26)

Air motors with pump tube

Motor	Tightening torque
84803	14.9 Nm
84804	14.9 Nm
84806	35.2 Nm
84808	71.9 Nm
86810	81.3 Nm

(Item 30)

Tightening torque = 5.6 Nm

Re-tighten screws after 24 hours

(Item 36) Tightening torque = 82-88 Nm

First wet adapter thread with Loctite 242 Blue.

(Pos. 37) Tightening torque = 14-16 Nm

#### 4.8 Material compatibility

The material to be supplied has to be compatible with the following materials:

- Steel / brass / copper / aluminium
- NBR

## 5. Delivery, returns and storage

### 5.1 Delivery

The product is packaged in accordance with standard commercial practice according to the regulations of the recipient's country. During transport, safe handling must be ensured.

After receipt of the shipment, the product must be inspected for damage and for completeness according to the shipping documents. The packaging material must be preserved until any discrepancies are resolved.

### 5.2 Returns

Before sending the product back, it must be cleaned and packed properly. The product must be protected from mechanical effects such as impacts. There are no restrictions for land, air or sea transport. The packaging has to be marked as follows.

### 5.3 General notes related to storage



- The product can be wrapped in plastic film to provide low-dust storage.
- Protection against ground moisture by storing on a shelf or wooden pallet.

### 5.4 Storage

SKF products are subject to the following storage conditions:

- Dry and dust-free surroundings, storage in well ventilated dry area.
- Storage time: max. 24 months
- Permissible humidity: < 65% (rh)

Storage temperature:

min. - 25 °C / max. + 70 °C

- Avoid direct sun or UV exposure.
- Shield product from nearby sources of heat and coldness.

## 6. Assembly

### 6.1 General information

Only qualified technical personnel may install, operate, maintain, and repair the progressive feeders described in the lifecycle manual. Qualified technical personnel are persons who have been trained, assigned, and instructed by the operator of the final product into which the progressive feeders are incorporated.

Such persons are familiar with the relevant standards, rules, accident prevention regulations, and operating conditions as a result of their training, experience, and instruction. They are qualified to carry out the required activities and in doing so recognize and avoid potential hazards.

Before assembling/ setting up the product, the packaging material and any shipping braces (e.g. plugs) must be removed.

The packaging material must be preserved until any discrepancies are resolved.

#### ATTENTION

Observe technical data (chapter 4).

### 6.2 Set-up and attachment

The product should be protected against humidity and vibration and should be installed in an easily accessible position to ensure all other installations can be carried out without any problem. For indications on the maximum admissible ambient temperature see the technical data. During assembly and during any drilling work, always pay attention to the following:

- o Other units must not be damaged by assembly work.
- o The product must not be installed within the range of moving parts.
- o The product must be installed at an adequate distance from sources of heat and coldness.
- o Maintain safety clearances and comply with local regulations for assembly and accident prevention.

### 6.3 Assembly dimensions

To ensure enough space for maintenance (e.g. change of cartridge) and for any disassembly of the product, provide sufficient space into each direction.

Air motor Part no.	Dimensions (mm)		
	A	B	C
84803	191	600	152
84804	191	600	152
84806	235	578	197
84808	286	578	243
84810	337	578	295

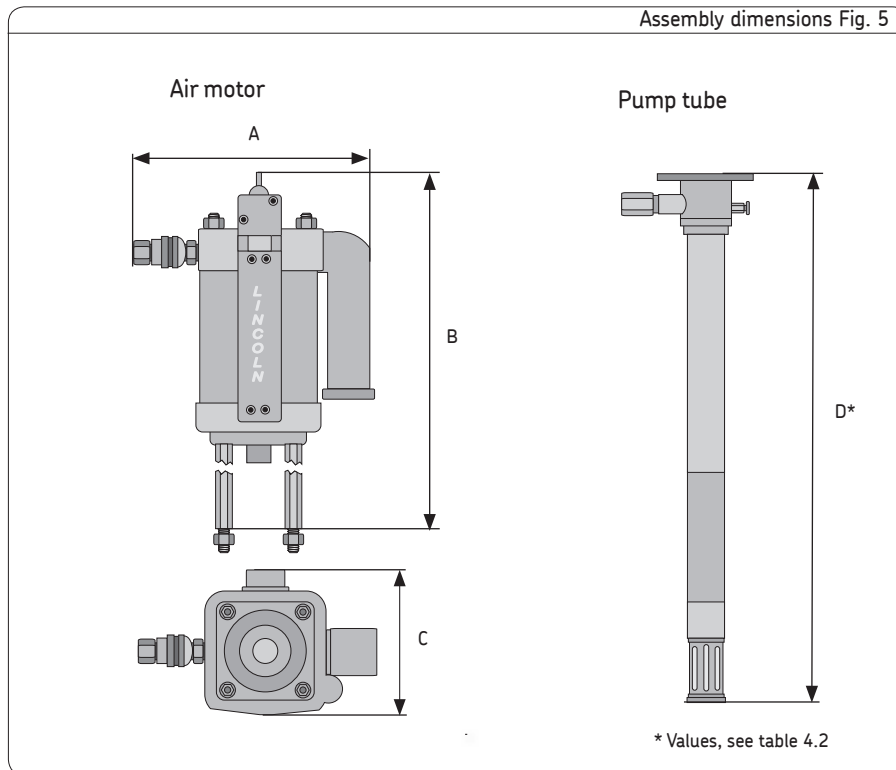

#### 6.4 Installation of the threaded rods

All four threaded rods must be of the same length.

- Screw threaded rods (7) with short threaded part into air motor (tightening torques, see chapter 4.7).
- Repeat procedure with all threaded rods.

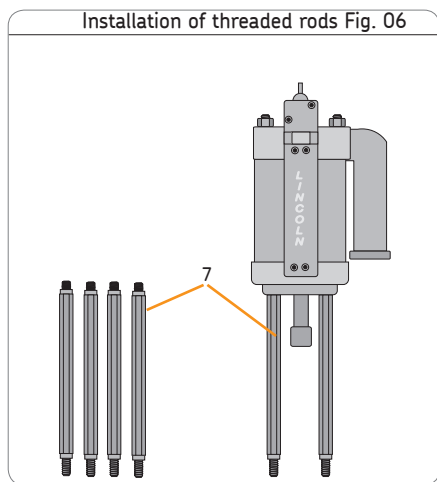

#### 6.5 Installation of the quick air coupling

When tightening ensure that the thread of the plug-in type fitting (7.1) is conical.

- Screw plug-in type fitting (7.1) into the threaded opening (3/4" NPTF) of the air motor.
- Install coupling (7.2) on plug-in type fitting.

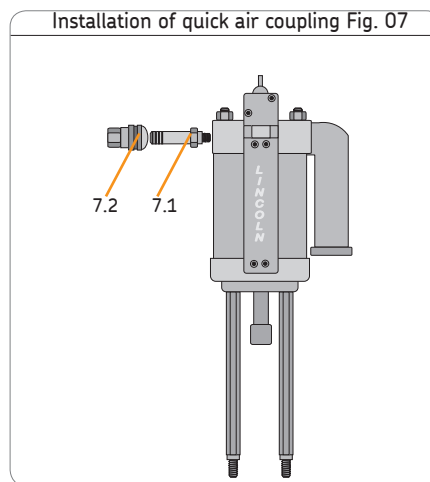

### 6.6 Connection of air motor and pump tube

Completely extend the piston rod (8) of the air motor, if necessary. To do so connect the air motor with the quick air coupling (7) to the compressed air supply. Increase the air pressure only slowly and to that extent that the piston rod extends slowly. Then open quick air coupling to depressurize the pump.

- Clamp the pump tube (4) directly below the outlet housing on the immersion tube into a vice (23). Clamp the pump tube only to that extent that is well fixed in the vice.
- Place the air motor (1) from the top onto the pump tube (4).
- Hand-screw the piston rod of the air motor (8) to the piston rod of the pump tube (14).

#### ATTENTION

The two piston rods have to be aligned with each other. Otherwise the sealing on the glands will wear prematurely.

- Insert the four threaded rods (13) into the bores of the flange on the pump tube.
- Tighten the screw connections of the piston rods with a wrench. Adhere to the tightening torques specified in chapter 4.7 Item 36.
- Hand-tighten the threaded rods (13) with the nuts on the flange.
- Install the compressed air supply on the quick air coupling (7) and let the air motor carry out few double strokes at low pressure (so that the air motor is just running).
- As soon as the air motor has reached its upper end position, remove the compressed air supply from the quick air coupling.
- Firmly tighten the nuts (15) on the threaded rods (13) crosswise using a wrench.

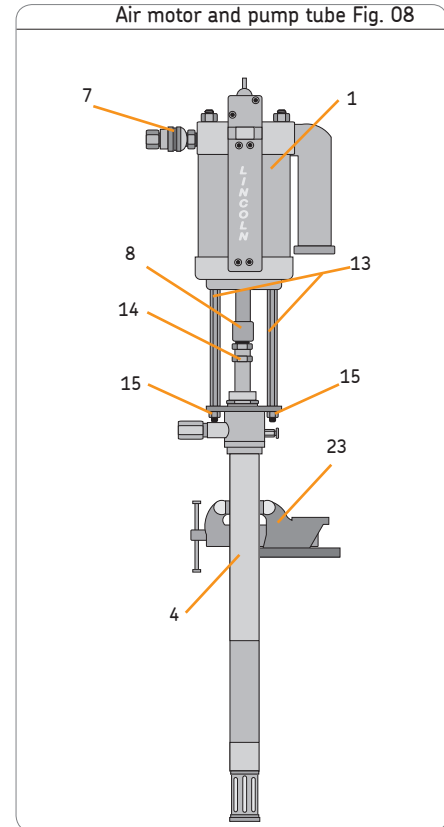

### 6.7 Installation of the protective cover

An operation of the PowerLuber without protective cover (3) and without cover plates (16) is not allowed. To mount the protective cover (3) proceed as follows:

- Position the two halves of the protective cover around the threaded rods and screw them together with the 4 screws. If not done yet, install the two cover plates (16).

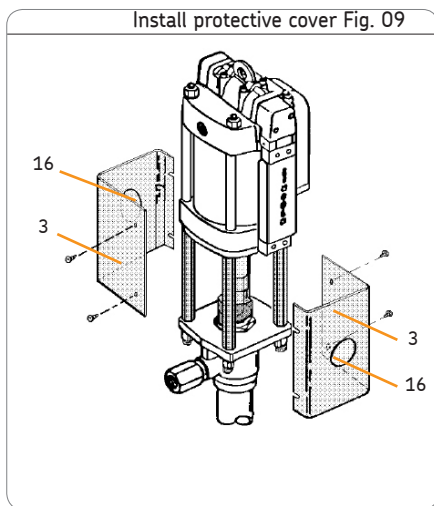

### 6.8 Compressed air connection

Connect the compressed air system of the operator via a suitable compressed air unit and the air quick coupling only. In case of pressure exceeding 7 bar there must be provided a pressure reducing valve.

- Connect the operator's compressed air system by means of a pneumatic hose to the air quick coupling (7).

The pneumatic hose must be dimensioned sufficiently long to cope with the maximum up- and downward way of movement and with the pressures of the PowerMaster III pump. During up- and downward movement of the PowerMaster III pump no tractive forces must affect the pneumatic hose.

## 7. Start-up/ operation

### 7.1 General information

Prior to commissioning, ensure that:

- the air line and the supply line have been routed correctly and are provided with a shut-off valve.
- earthing of the PowerMaster III pump and between the container and the PowerMaster III pump has been provided and is fully functional.
- the maximum admissible operating pressure of the PowerMaster III pump is not exceeded.
- control and monitoring parts are available and fully functional, e.g.:
  - pressure limiting valve
  - pressure relief valve
  - Shut-off device for low-level signal
  - Shut-off device for stroke frequency
  - Maintenance unit/ air pressure regulator with pressure gauge.

Now the PowerMaster III pump is ready for operation.

#### NOTE

In case of new systems further installation steps may be required depending on the overall system and the local ambient conditions. Please refer to the Instructions of the manufacturer of the overall system respectively to the operator's supplements.

### 7.2 Adjustment of the correct air pressure

Depending on the material to be supplied and its suction behaviour the air pressure must be increased slowly. The air pressure can be adjusted finally only after venting all lines and correct suction of the material to be supplied.

## 8. Shutdown and disposal

### 8.1 Temporary shutdown

#### Temporary shutdown

- Interrupt the compressed air supply.

### 8.2 Final shutdown and disposal

If the product will be permanently shut down, the local regulations and laws regarding the disposal of contaminated equipment must be observed.

The product can also be returned to the manufacturer for disposal, in which case the customer is responsible for reimbursing the costs incurred. The parts are recyclable.

## 9. Maintenance

### 9.1 General information

The manufacturer shall not be held liable for damages resulting from improperly performed assembly, maintenance or repair work on the product.

### 9.2 Cleaning

Thoroughly clean all outside surfaces. Do not use aggressive cleaning agents. Interior cleaning normally is not necessary.

### 9.3 Maintenance

The PowerMaster III pump requires almost no maintenance. To avoid malfunctions and damages the following actions have to be carried out. The actions refer to personnel trained in maintenance with special knowledge of hydraulics and pneumatics.

#### NOTE

The item numbers refer to the indications in the spare parts drawings and spare parts lists.

### 9.4 Required tools

#### Hexagon wrench

7/64"; 5/32", 3/16"

#### Flat wrench

1/2" und 1-1/4" (for air motor 84803 and 84804)

3/4" (for air motor 84806)

15/16" (for air motor 84808)

1-1/8" (for air motor 84810)

#### Torque wrench

0-20 Nm for hex wrench 3/16"

#### Screwdrivers and pliers of different sizes

### 9.5 Maintenance of the pilot block

To carry out the maintenance of the pilot block, proceed as follows:

- Unscrew the 4 screws (23) and remove the pilot block from the air motor. Make sure the two O-rings (35) on the rear side of the pilot block do not get lost.
- Unscrew the 2 screws (39) and remove the pneumatic relay valve (17).
- Unscrew the 4 screws (40) and remove the upper (31) and lower (32) housing brackets.

- Remove the 2 air signal valves (20) from the pilot block.
- Blow the bores in the pilot valve housing with compressed air.
- Clean the pneumatic relay valve (17), if necessary, replace it by a new pneumatic valve.

Reassembly is effected in reverse order. Use new seals for the assembly (kit of seals part no. 84967).

### 9.6 Maintenance of the sound absorber

- Remove the 2 screws (30) with a hex wrench and pull off the sound absorber housing together with the seal (28).
- Remove the screw (47), then remove the sound absorber plate (46) and the end plate (45).

- Remove the sound absorber element (43) from the housing.
- Clean the sound absorber element (43), replace by a new sound absorber element (43), if necessary.

Reassembly is effected in reverse order.

Observe indications regarding the torque to follow (chapter 4.7, Pos 30) beachten.

### 9.7 Maintenance of the control valve

- Remove screws (27 + 34).
- Remove valve end caps ( 10 + 14).
- Push valve piston (13) out of the valve housing (12).
- Remove piston valve bumpers (9) from the valve end caps (10+14).
- Remove the two O-rings (11) from the valve body.
- Remove the 4 screws (37) and lift out valve body (12) and seal (15).
- Check valve piston (13) and valve body (12) and in case of damage or wear replace by new assembly (see 11.3).

- Reassembly to be effected in reverse order. For assembly:
  - Use new seals (part no. 84968).
  - Lightly oil the piston rings of the valve piston.
  - Adhere to the specifications regarding the torque to follow regarding the screws (37) (chapter 4.7, item 37).

### 9.8 Maintenance of the drive cylinder

- Remove pilot block and sound absorber element as previously described.
- Remove nuts (26).
- Lift upper head of cylinder (8) upwards.
- Remove the 4 threaded rods (25) from the lower cylinder head (22) .
- Remove tube (7).
- Remove cylinder tube (6) upwards.

#### Air motor versions 84806, 84808, 86810

- Pull out piston with piston rod (5). In case of air motor 86810 additionally the pistons with piston rods have to be disassembled (items 5.1 to 5.5).

#### Air motor versions 84803 and 84804

- Unscrew adapter (36) from piston rod. The adapter is secured by Loctite 242 Blue. Observe the specifications regarding the torque to follow (chapter 4.7, item 36).

#### All air motors

- Unscrew the 4 threaded rods (41) out of the cylinder head.
- Check cylinder tube (6). If the inner sliding rails are damaged, replace the cylinder tube.
- Check piston and piston rod (5) and replace in case of damage.
- Check all further parts of the cylinder head and replace in case of damages.

- Reassembly is effected in reverse order.  
For assembly:
  - Use new seals (sealing kits, see 11.8).
  - Oil the grooved ring (1) and the bushing (2) of the piston with piston rod (5).
  - Observe the specifications regarding the torque to follow for the screw (5.1), the screws (26) and the adapter (36) (chapter 4.7, item 5.1).
  - Provide the adapter (36) with Loctite 242 Blue.
  - Align the cylinder tube (6). The cylinder tube is aligned correctly, if the 2 small bores on the cylinder bore align with the rear-side bores on the pilot valve body (24) and are covered completely by the O-rings (35). Only after aligning the cylinder tube (6) firmly tighten the nuts (26).

### 9.9 Test run

Before attaching the air motor to the pump tube, the air motor should pass a short test run at the lowest possible air pressure. Ensure that the piston rod (5.5) extends freely.

Attach the air motor as described in chapter 6 Assembly (6.6).

## 10. Troubleshooting

Fault	Possible cause	Remedy
Air motor does not start.	Check air supply (too low or lacking air pressure). Outlet clogged.	Check air pressure and increase, if necessary. Check outlet and supply line.
Air motor does not change to opposite stroke direction and continuously blows air out of the sound absorber.	Check air supply (too small air volume).	Check air pressure (air volume) and increase, if necessary.
Air motor runs at uneven stroke frequency and with abridged length of stroke.	Air relay valve and/or air signal valve in the air motor contaminated or worn.	Clean or replace pilot block subassembly on the air motor.
Pump runs at uneven stroke frequency. However no increase of flow volume when stroke frequency increases.	Air inclusions in the pump tube. Only small amount of material to be supplied available. Material to be supplied cannot be sucked in properly as it is too highly viscous and/or the stroke frequency is too high. Note: Viscosity increase through changing temperature.	Carry out venting following the instructions of initial start-up. Change/ refill container. Throttle the output flow on the outlet valve. In case of pump with pressing device, increase the contact pressure of the follower plate. Check suction adapter/ suction line with regard to possible clogging, if so, eliminate clogging.
Pump supplies during downward stroke only.	Set of plunger-in-bushing style piston or valve damaged or worn.	Check parts and replace defective parts.
Pump supplies during upward stroke only.	Inlet valve damaged or worn. Poor material intake due to restrictions in the inlet or suction line. Too high viscosity of material to be supplied and too high stroke frequency.	Check inlet valve and replace defective parts. Verify material intake and remedy defects and restrictions. Throttle output flow at the outlet of the system (material dispensing valve).
Pump runs but does not supply.	Inlet valve not seated correctly or damaged.	Check inlet valve and replace, if defective.
Pumpe läuft bei geschlossenem Förderauslass weiter.	Leckage in Förderleitung/System. Stopfbuchsenabdichtung undicht.	Prüfen und abdichten. Pumpenrohr prüfen, instandsetzen.

## 11. Spare parts

### 11.1 Pilot block assembly

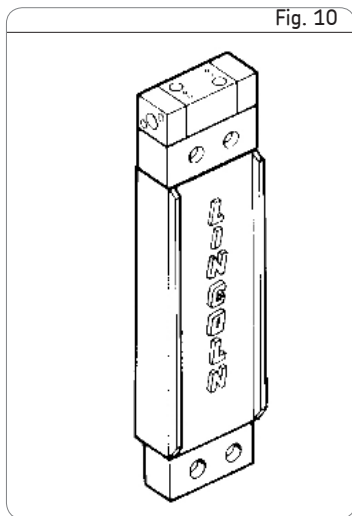

#### Order numbers

84967X Set of seals for pilot block  
 242799 Pilot block for air motor 84803  
 242786 Pilot block for air motor models  
 84804, 84806, 84808, 86810

### 11.2 Sound absorber assembly

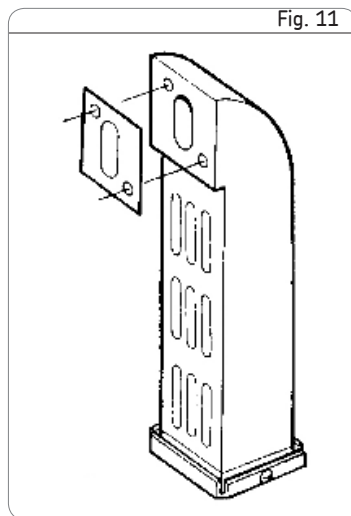

#### Order numbers

242788 (with seal)  
 84939 (with seal and felt)

### 11.3 Subassembly - Control valve PowerMaster III air motors

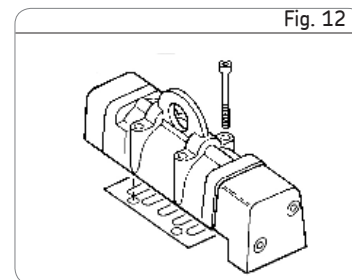

#### Order numbers

244808 (air motors 84803 / 84804)  
 244806 (air motor 84806)  
 244804 (air motor 84808)  
 244800 (air motor 84810)

#### 11.4 Subassembly - control valve body with valve piston

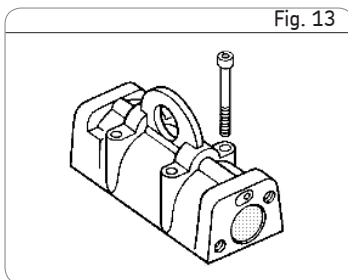

Order no. 24480

#### 11.5 Subassembly - pilot block air relay valve

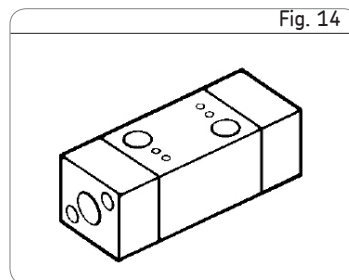

Order no. 24787

#### 11.6 Subassembly - pilot block air signal valve

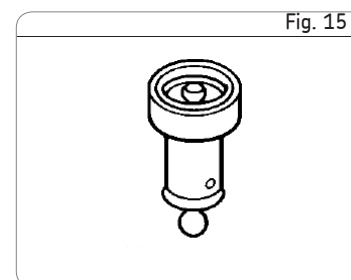

Order no. 41768

#### 11.7 Protective cover for PowerMaster III air motor (2 parts)

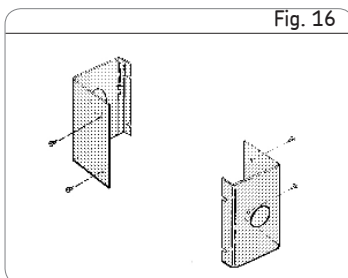

Order no. 84723

#### 11.8 Set of seals for drive cylinder

Order no.	PowerMaster III air motor	Cylinder diameter
84794	84803	3" (approx. 76 mm)
84793	84804	4-1/4" (approx. 108 mm)
84792	84806	06" (approx. 152 mm)
84791	84808	08" (approx. 203 mm)
84789	84810	10" (approx. 254 mm)

11.9 Spare parts for PowerMaster III air motors

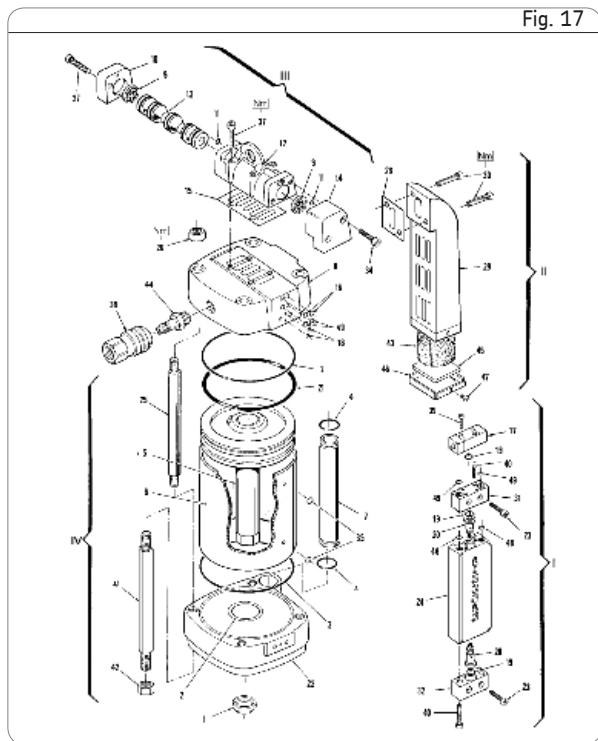

Fig. 17

I = Pilot block assembly  
 III = Control valve assembly

II = Sound absorber assembly  
 IV = Components of the drive cylinder

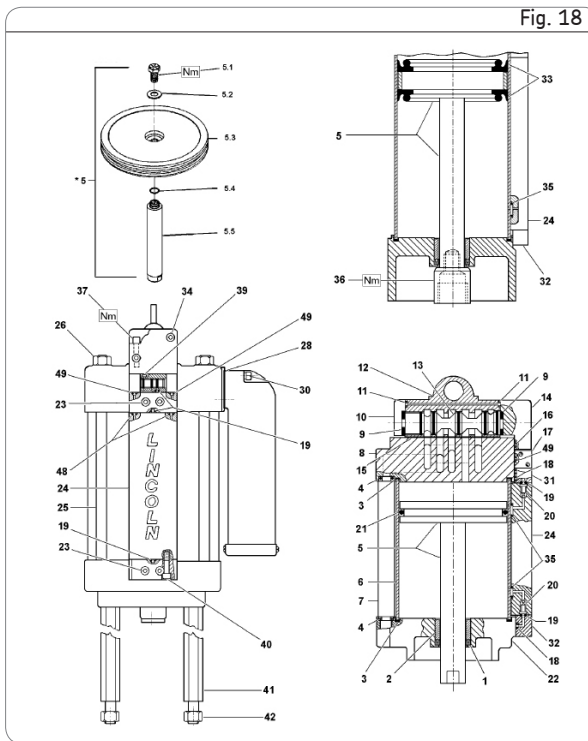

Fig. 18

Item	Designation	Qty.	Part numbers of the different air motors				
			86810	84808	84806	84804	84803
1	Grooved ring (NBR)	1	# 8	#1	#2	#3	#4
2	Bushing	1	247296	241732	241732	241733	241733
3	Cylinder seal (NBR)	2	#8	#1	#2	#3	#4
4	O-ring (NBR)	2	#8	#1	#2	#3	#4
5	Piston rod assembly	1	247449	241740	241741	241742	241743
5.1	Screw	1	272736	-----	-----	-----	-----
5.2	Washer	1	272737	-----	-----	-----	-----
5.3	Piston	1	272766	-----	-----	-----	-----
5.4	O-ring (NBR)	1	#8	-----	-----	-----	-----
5.5	Piston rod	1	272767	-----	-----	-----	-----
6	Cylinder tube	1	247448	241744	241745	241746	241747
7	Tube	1	247336	241788	241748	241749	241749
8	Upper cylinder head	1	247304	241750	241751	241752	241753
9	Valve piston bumper	2	#7	#7	#7	#7	#7
10	Valve end cap	1	241755	241755	241755	241755	241755
11	O-ring (NBR)	2	#7	#7	#7	#7	#7
12	Valve housing	1	#9	#9	#9	#9	#9
13	Valve piston	1	#9	#9	#9	#9	#9
14	Valve end cap	1	247302	241759	241760	241761	241761
15	Seal	1	#7	#7	#7	#7	#7
16	O-ring (NBR)	2	#7	#7	#7	#7	#7
17	Air relay valve	1	242787	242787	242787	242787	242787
18	O-ring (NBR)	3	#6	#6	#6	#6	#6
19	O-ring (NBR)	3	#6	#6	#6	#6	#6

#1 Part of part no.: 84791 (Set of seals for cylinder 8")

#6 Part of part no.: 84967 (Set of seals for pilot block)

#2 Part of part no.: 84792 (Set of seals for cylinder 6") #7 Part of part no.: 84968 (Set of seals for control valve)

#3 Part of part no.: 84793 (Set of seals for cylinder 4 1/4")

#8 Part of part no.: 84789 (Set of seals for cylinder 10")

#4 Part of part no.: 84794 (Set of seals for cylinder 3") #9 Part of part no.: 244802 (Housing with valve piston)

#5 Part of part no.: 84939 (Spare parts kit sound absorber)



Item	Designation	Qty.	Part numbers of the different air motors				
			86810	84808	84806	84804	84803
20	Air signal valve	2	241768	241768	241768	241768	241768
21	O-ring (NBR)	1	#8	#1	#2	-----	-----
22	Lower cylinder head	1	247303	241773	241774	241775	241776
23	Screw	4	50526	50526	50526	50526	50526
24	Pilot valve body	1	241778	241778	241778	241778	241778
25	Threaded rod	4	247295	241766	241779	241767	241767
26	Nut	4	247298	51018	51007	51001	51001
27	Screw	2	244995	244995	244995	244995	244995
28	Seal	1	#5	#5	#5	#5	#5
29	Sound absorber body	1	241021	241021	241021	241021	241021
30	Screw	2	50051	50051	50051	50051	50051
31	Upper housing bracket	1	241784	241784	241784	241784	241784
32	Lower housing bracket	1	241785	241785	241785	241785	241785
33	Packed pistons	2	-----	-----	-----	#3	#4
34	Screw	2	247299	244993	2411783	244994	244994
35	O-ring (NBR)	2	#6	#6	#6	#6	#6
36	Adapter	1	-----	-----	-----	241789	241789
37	Screw	4	244975	244975	244975	244975	244975
38	Quick coupling (air)	1	662012	655012	655012	655008	655008
39	Screw	2	50816	50816	50816	50816	50816
40	Screw	4	50823	50823	50823	50823	50823
41	Threaded rod	4	241023	241023	241023	241023	241023
42	Nut	4	236203	236203	236203	236203	236203
43	Sound absorber element	1	#5	#5	#5	#5	#5
44	Plug-in fitting	1	660112	660112	660112	660112	660112
45	End plate	1	#5	#5	#5	#5	#5
46	Sound absorber plate	1	241027	241027	241027	241027	241027
47	Self-tapping screw	2	66962	66962	66962	66962	66962
48	O-ring (NBR)	2	#6	#6	#6	#6	#6
49	O-ring (NBR)	4	#6	#6	#6	#6	#6

### 12.1 Specific safety indications for air-driven pump hoists

Lincoln pump hoists are accessories for Lincoln barrel pumps of the PowerMaster III and PileDriver III series.

It is prohibited to operate PowerMaster III and PileDriver III pumps with other makes of pump hoists. This could result in undefined operating conditions that could endanger persons and might result in damage to material assets.

- Do not use the pump hoist to lift other loads.
- Use the pump hoist only in combination with the corresponding Lincoln pumps.
- Do not overload the pump hoist. Max. 90 kg may be lifted (pump including all other components to be lifted).
- Use the pump hoist in rooms of at least 3 meters height.
- Dimension the air hoses corresponding to the stroke travel distance.
- Use pump hoist only when screwed firmly to the ground.
- Always operate the pump hoist within the admissible technical limits.
- Never exceed the maximum admissible air pressures of pump, pump hoist or other system components.
- During assembly no parts must be below the mounting place. Falling tools or parts may cause personal injuries.
- Risk of falling: During assembly bear in mind steps, e.g. bottom panels or objects on the floor.
- While the pump is moved, e.g. when changing the barrel or lowering the pump, do not touch the rim of the barrel nor the follower plate as limbs could be crushed.
- While lowering the pump ensure that no persons or components (except from the proper barrel) are positioned below the follower plate. Persons could be crushed or the follower plate could be damaged.
- Never grasp into the suction bore of the pump tube while pump is operating.
- Keep unauthorized persons away.

	 <b>WARNING</b>
	<p><b>Risk of crushing</b> During operation or travelling of the pump:</p> <ul style="list-style-type: none"> <li>○ Never touch the rim of the barrel or the follower plate.</li> <li>○ Never bend over the barrel or stay below the pump.</li> </ul>

**12.2 Technical data of the pump hoists**

	<b>Pump hoist model 2710</b>	<b>Pump hoist model 2740</b>
Kind of drive:	compressed air	compressed air
Driving compressed air:	min 2.8 bar / max 7.0 bar	min 2.8 bar / max 7.0 bar
Extended height:	1580 mm	1525 mm
Retracted height:	2616 mm	2463 mm
Lifting capacity:	max. 90 kg	max 90 kg
Suitable barrels:	400 LB (180 kg round barrel)	400 LB (180 kg round barrel)
Weight:	approx. 40 kg	approx. 40 kg

### 12.3 Operating and control elements of the pump hoist

In addition to the operating and control elements of the PowerMaster III pump, the pump hoist disposes of the following operating and control elements.

#### 10 Control valve of pump hoist

The control valve of the pump hoist serves to move the PowerMaster III pump up and down. The PowerMaster III pump may be moved only while being idle. When moving the pump upwards, it may be necessary to vent the barrel before (see 17).

#### 17 Follower plate venting

Serves to vent the space below the follower plate, e.g. to facilitate an easy exchange of the barrel.

#### 21 Follower plate venting

Serves to vent the space below the follower plate when lowering the pump. Open the follower plate venting by hand (anticlockwise). As soon as the follower plate has been

lowered completely onto the material to be supplied, the follower plate venting must be closed again (clockwise).

#### 44 Air pressure regulator

Serves to adjust the operating air pressure of the pump hoist. The air pressure may be adjusted only that high that the pump can be moved slowly with the control valve (10) of the pump hoist.

If the operating air pressure is adjusted too high, the pump moves fast. This may result in damages or dangerous situations.

#### 35/45 Shut-off valve - air supply of pump

To operate the PowerMaster III pump the shut-off valve must be open. When moving the pump hoist (change of barrel) or for maintenance purposes the shut-off valve must be closed.

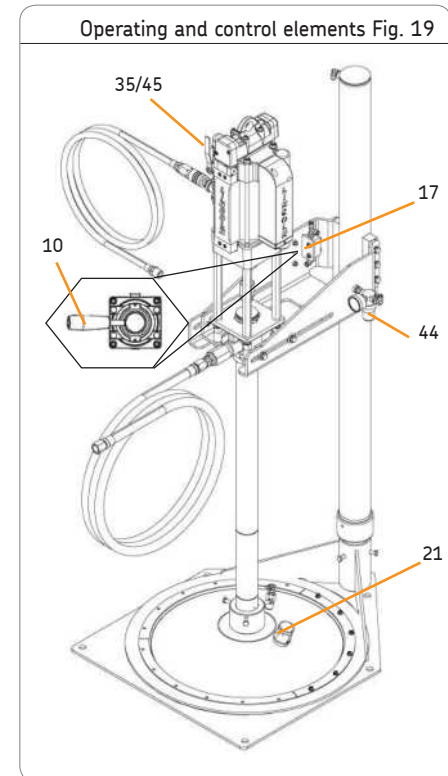

### 12.4 Installation of the pump hoist

- Transport the pump hoist to the place where it will be used.
- Connect the pump hoist on the 4 fastening points (20), e.g., with anchor bolts to the foundation.
- Insert pre-assembled PowerMaster III pump with pump tube in the support. If required, use an indoor crane.
- Align PowerMaster III pump vertically and screw it to the support with the 4 screws (19).
- Mount the follower plate and connect it pneumatically to the pump hoist.
- Connect PowerMaster III pump and pump hoist to the operator's compressed air supply (conditions, see chapter 6 Assembly of the PowerMaster III pump).

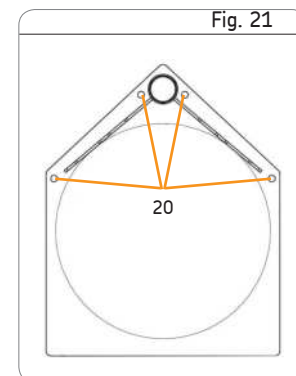
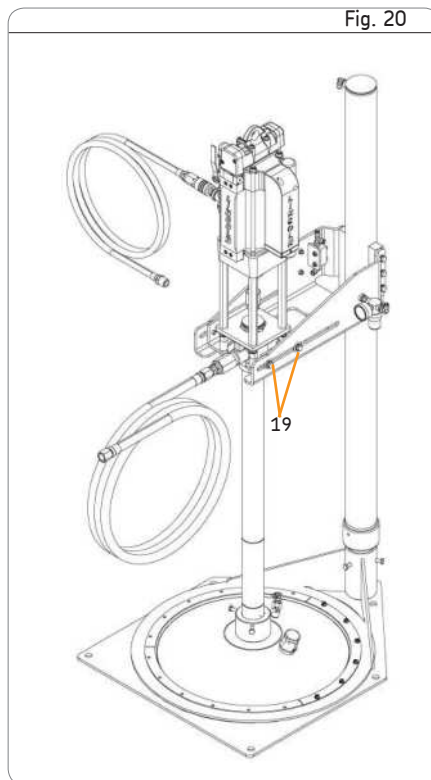

### 12.5 Installation of barrel

- Move pump hoist by means of the pump hoist control valve (10) that high that the barrel can be installed.
  - Move the barrel towards the bumpers (22) of the base plate and align it.
  - Open the follower plate venting (21). Lower the follower plate by means of the pump hoist control valve (10) into the barrel until it is seated on the material to be supplied.
  - Close the follower plate venting (21).
  - Open the shut-off valve (35) of the air supply of the PowerMaster III pump.
- The PowerMaster III pump is ready for operation.

### 12.6 Remove barrel

To remove an empty barrel proceed as follows:

- Close the shut-off valve (35) of the air supply of the PowerMaster III pump.
  - Parallely activate the pump hoist control valve (10) and the follower plate venting (17).
  - As soon as the follower plate has moved out of the barrel, release the pump hoist control valve (10) and the follower plate venting (17).
  - Remove the empty barrel from the pump.
- Install new barrel as described under 12.5.

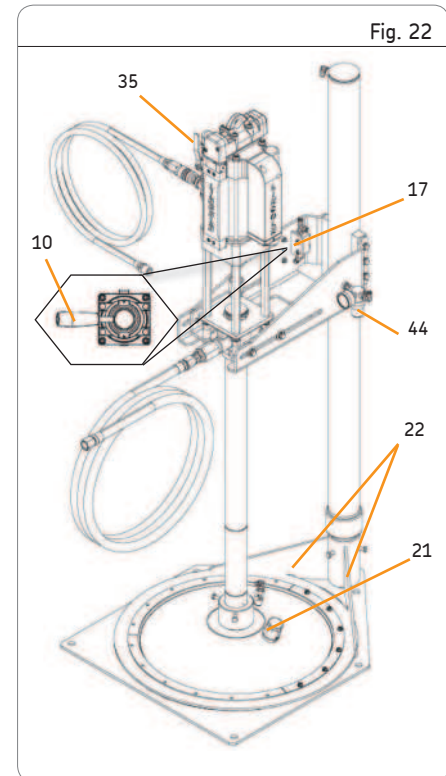

## 12.7 Spare parts of pump hoist

Fig. 23

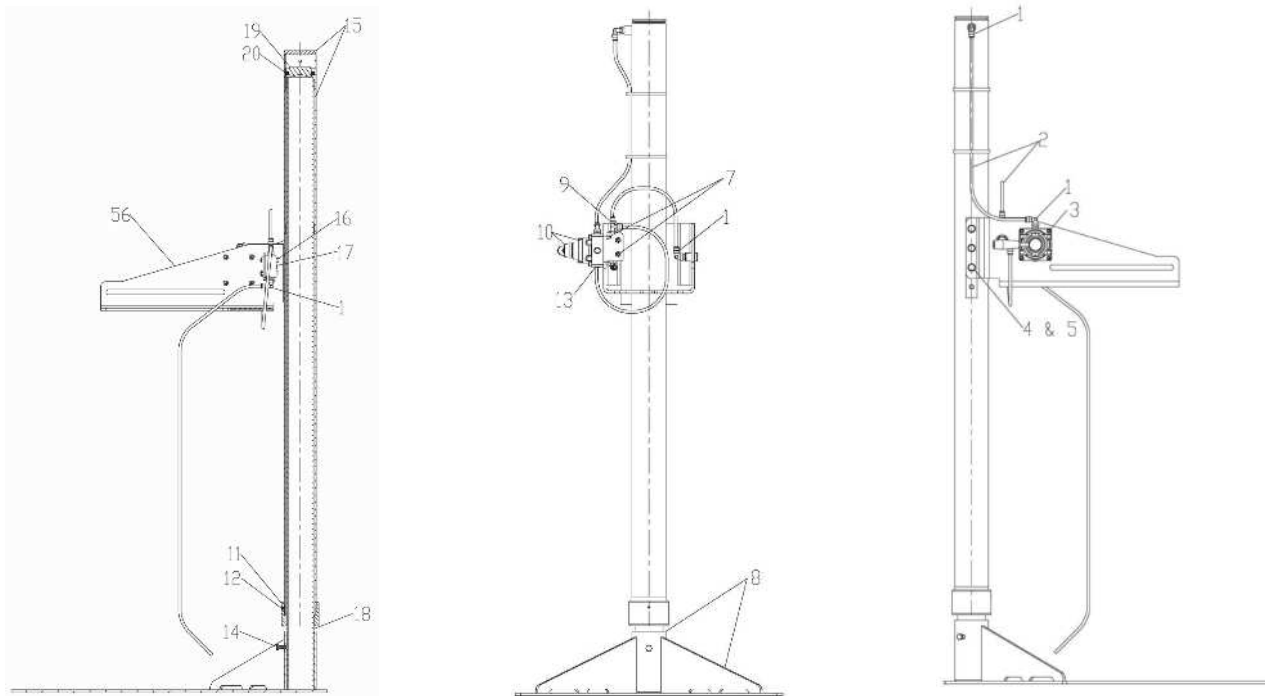

Fig. 24

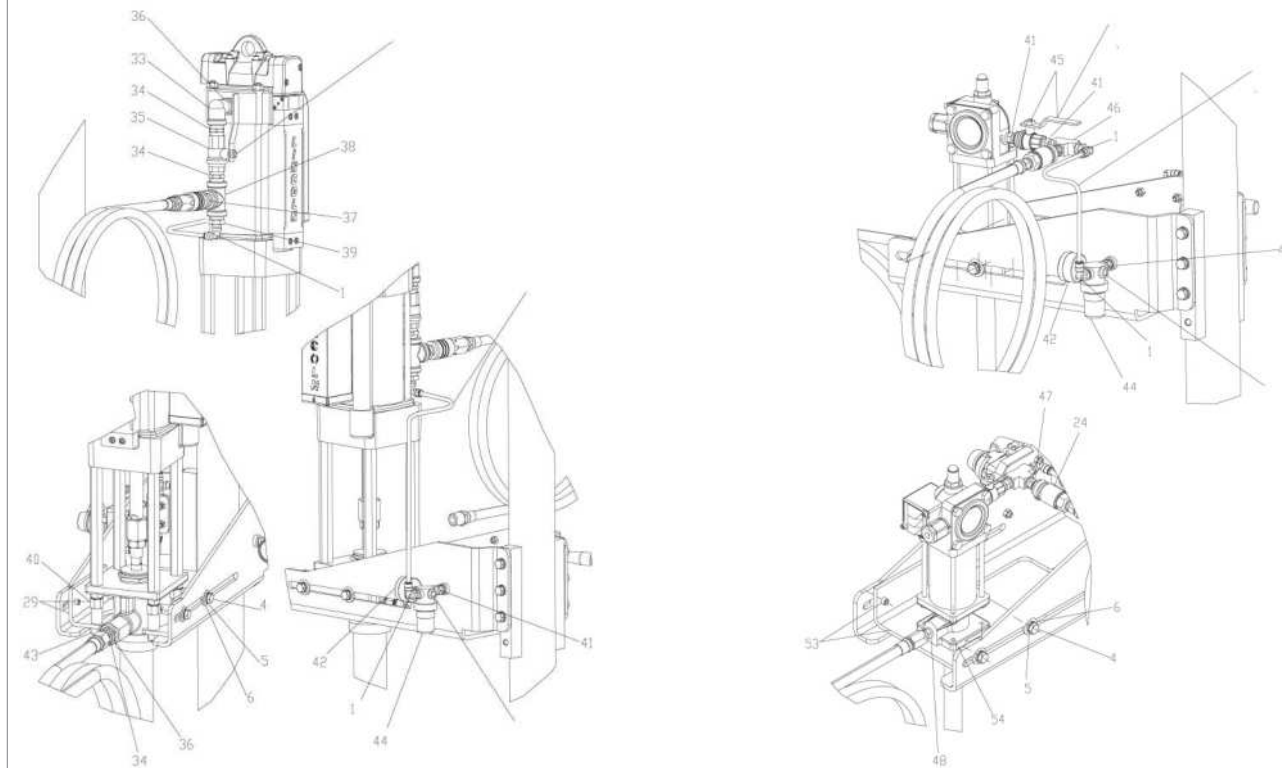
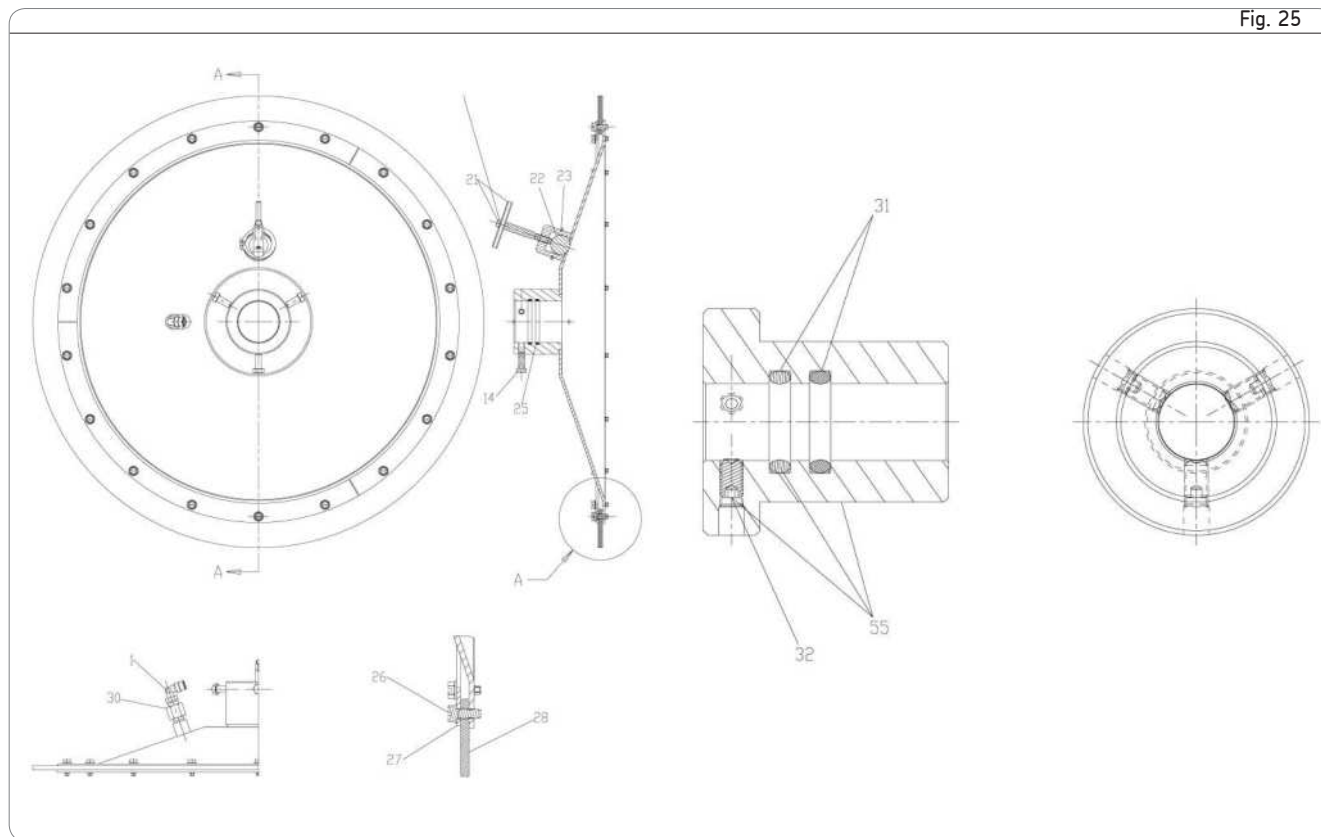
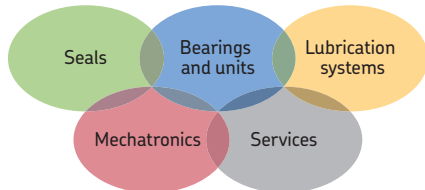

Fig. 25



Item	Designation	Part number	Required quantities for pump hoist	
			2710	2740
1	1/4 OD X 1/4 NPTF (M) 90° ELL	247761	7	7
2	1/4 OD X .160 ID Polyurethane hose		as required	as required
3	1/4-20 x 1-3/4" cylinder screw	50779	4	
4	3/8-16 X 1 hex screw	50044	10	10
5	3/8 circlip	66220	10	10
6	3/8 flat washer	48268	4	4
7	1/4-20 hex nut	51010	6	6
8	Mounting plate	274661	1	1
9	1/4 T-piece, male	274654	1	1
10	4-way air valve	237588	1	1
11	Tube cap	274719	1	1
12	#10-32 X 1/4" threaded pin with ferrule	50522	1	1
13	1/4 NPT closure plug	67359	1	1
14	5/16-18 X 3/4" cylinder screw	50016	6	6
15	Upper support tube	274666	1	1
16	1/4-20 X 1-1/2 cylinder screw	50051	2	2
17	2-way air valve	274682	1	1
18	Lower support tube	274664	1	1
19	Piston	274663	1	1
20	Piston seal	34327	1	1
21	Valve screw	274651	1	1
22	1" ball	274715	1	1
23	Retaining ring	274650	1	1
24	Air connection	238208	----	1
25	O-ring (nitrile)	34337	2	2
26	1/4-20 X 5/8" tapping screw	274648	18	18
27	Follower segment	274644	3	3
28	Wiper ring (nitrile)	34371	1	1
29	Pump mount assy., PM3 (incl. 4, 5, 6, 0,43)	274733	1	----
30	Check valve	274653	1	1

Item	Designation	Part number	Required quantity for pump hoist	
			2710	2740
31	O-ring (nitrile)	274678	----	2
32	5/16-18 X 1/2" threaded pin with ferrule	50525	----	3
33	1/2 NPT St. Ell.	67074	1	----
34	1/2 NPT hex nipple	11197	3	----
35	1/2 NPT ball valve	66084	1	----
36	1/2 NPT X 3/4 NPT bushing	67171	2	----
37	Air connector	650108	1	----
38	1/2 NPT T-piece	67041	1	----
39	1/4 NPT X 1/2 NPT bushing	12080	1	----
40	Extension adapter	242328	4	----
41	1/4 NPT hex nipple	10462	1	3
42	Pressure gauge	247843	1	1
43	1/2-13 UNC hex nut	51014	4	----
44	Mini pressure regulator	602003	1	1
45	1/4 NPT ball valve	274771	----	1
46	1/4 NPT T-piece	67102	----	1
47	Air connector	238394	----	1
48	Hose connector	10198	----	2
49	1/2" X 84" air hose	273304	1	----
50	3/8" X 84" high-pressure hose	274727	1	----
51	1/4" X 84" air hose	274728	----	1
52	1/4 X 84" high-pressure hose	236921	----	1
53	Pump mounting assy, SER 40 (including 4, 5, 6, 54)	274734	----	1
54	1/4-20 X 9/16 hex screw and flat washer	50060	----	4
55	Follower adapter (including 31 & 32)	274679S	----	1
56	Pump support	274669	1	1



### The Power of Knowledge Engineering

Drawing on five areas of competence and application-specific expertise amassed over more than 100 years, SKF brings innovative solutions to OEMs and production facilities in every major industry worldwide. These five competence areas include bearings and units, seals, lubrication systems, mechatronics (combining mechanics and electronics into intelligent systems), and a wide range of services, from 3-D computer modelling to advanced condition monitoring and reliability and asset management systems. A global presence provides SKF customers uniform quality standards and worldwide product availability.

### Important information on product usage

All products from SKF may be used only for their intended purpose as described in this brochure and in any instructions. If operating instructions are supplied with the products, they must be read and followed.

Not all lubricants are suitable for use in centralized lubrication systems. SKF does offer an inspection service to test customer supplied lubricant to determine if it can be used in a centralized system. SKF lubrication systems or their components are not approved for use with gases, liquefied gases, pressurized gases in solution and fluids with a vapor pressure exceeding normal atmospheric pressure (1 013 mbar) by more than 0,5 bar at their maximum permissible temperature.

Hazardous materials of any kind, especially the materials classified as hazardous by European Community Directive EC 67/548/EEC, Article 2, Par. 2, may only be used to fill SKF centralized lubrication systems and components and delivered and/or distributed with the same after consulting with and receiving written approval from SKF.

951-181-006-EN  
07/2014

Lincoln Industrial, One Lincoln Way  
St. Louis, MO 63120-1578 USA  
Tel: +1.314.679.4200  
Fax: +1.800.424.5359  
E-mail: [lincoln@lincolnindustrial.com](mailto:lincoln@lincolnindustrial.com)  
[www.lincolnindustrial.com](http://www.lincolnindustrial.com)  
[www.skf.com/lubrication](http://www.skf.com/lubrication)