

Fluid Level and
Temperature Indicators

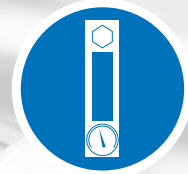

Tank Filler Breathers

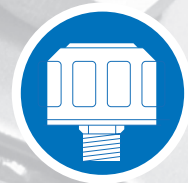

Giant and Desiccant Air Breathers



Suction Strainers



Diffusors



Germany

Walter Stauffenberg GmbH & Co. KG

Im Ehrenfeld 4

58791 Werdohl

Tel.: +49 2392 91 60

Fax: +49 2392 91 61 60

E-Mail: sales@stauff.com

www.stauff.com

STAUFF products and services are globally available through wholly-owned subsidiaries and a tight network of authorised distributors and representatives in all major industrial regions of the world.

You can find detailed contact information on the last two pages of this product catalogue or at www.stauff.com.

Please note: Unless otherwise stated, all data and figures in this product catalogue are approximate values and are only valid as references, which are not binding (also in respect to any third parties' rights of protection) and thus do not release the customer / user from checking and testing the suitability of the products for the foreseen purposes. Therefore, data and figures can only be used in a limited sense for construction purposes.

The application of the products is beyond the control possibilities of the manufacturer and, therefore, is exclusively subject to the responsibility of the customer / user.

In the event that a liability is nevertheless considered, any compensation will be limited to the value of the goods supplied by the manufacturer and used by the customer / user. As a matter of course, the manufacturer guarantees the perfect quality of all products in accordance with the General Terms and Conditions of Business and Sale.

Subject to modifications due to the ongoing development and improvement of the products.

With the publication of this product catalogue, previous editions are no longer valid.

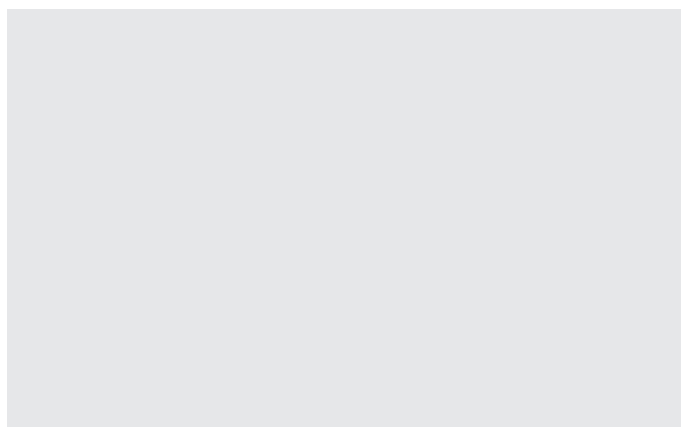
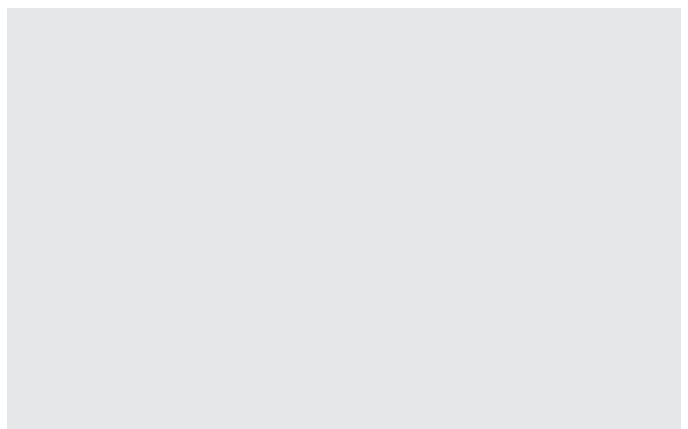

Introduction	4 - 11	
Fluid Level and Temperature Indicators	12 - 21	A
Tank Filler Breathers	22 - 39	B
Giant and Desiccant Air Breathers	40 - 47	C
Suction Strainers	48 - 51	D
Diffusors	52 - 55	E
Appendix (Product-Specific Abbreviations / Global Contact Directory)	56 - 63	





Catalogue 1 STAUFF Clamps

- Block Clamps
- Special Clamps
- Light Series Clamps
- Saddle Clamps
- U-Bolt Clamps
- Metal Clamps
- Construction Series



Catalogue 2 STAUFF Connect

- Tube Connectors
- Assembly Tools and Devices

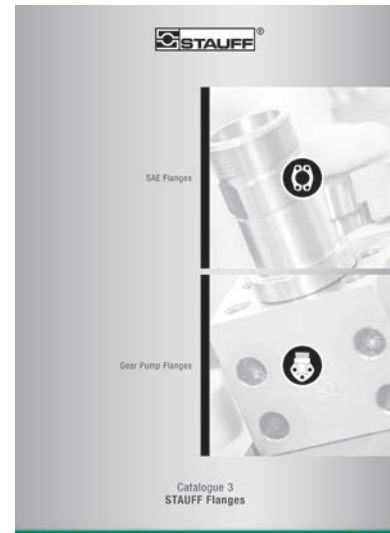

Catalogue 3 STAUFF Flanges

- SAE Flanges
- Gear Pump Flanges



Catalogue 4 VOSWINKEL Hose Connectors

- Hose Connectors
- High-Pressure Hose Connectors

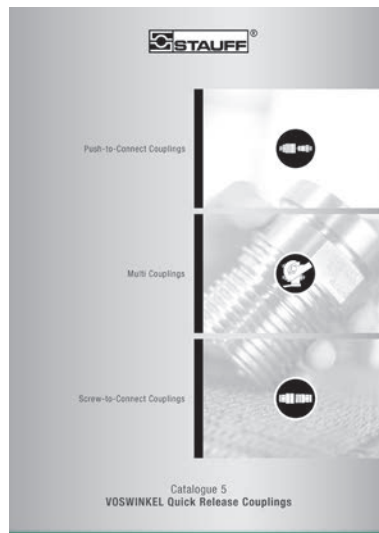

Catalogue 5 VOSWINKEL Quick Release Couplings

- Push-to-Connect Couplings
- Multi Couplings
- Screw-to-Connect Couplings



Catalogue 6 STAUFF Valves

- Two-Way Ball Valves
- Multi-Way Ball Valves
- Flow Control and Check Valves
- Gauge Isolator Valves





**Catalogue 7
STAUFF Test**

- Test Couplings
- Test Adaptors
- Test Hoses and Connectors



**Catalogue 8
STAUFF Diagtronics**

- Pressure Gauges
- Hydraulic Testers
- Oil Analysis Equipment



**Catalogue 9
STAUFF Filtration Technology**

- Replacement Filter Elements
- Pressure Filters
- Return-Line Filters
- In-Line Filters
- Spin-On Filters
- Offline and Bypass Filters
- Filtration Systems

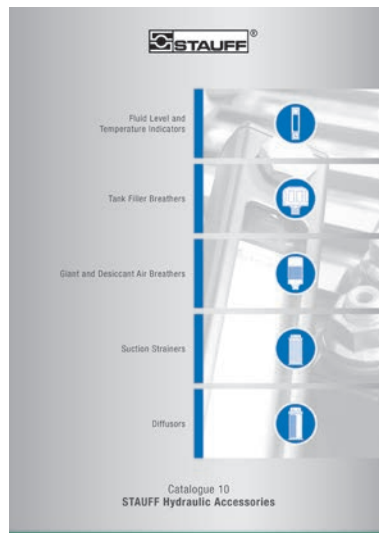

**Catalogue 10
STAUFF Hydraulic Accessories**

- Fluid Level and Temperature Indicators
- Tank Filler Breathers
- Giant and Desiccant Air Breathers
- Suction Strainers
- Diffusers



For more than 50 years, the companies of STAUFF Group have been developing, manufacturing and distributing pipework equipment and hydraulic components for mechanical and plant engineering and for service and industrial maintenance.

In addition to mobile and industrial hydraulic machinery, typical applications also include commercial and special purpose vehicles, rail transportation and energy technology. Likewise, STAUFF products are used in marine, oil and gas applications and in the process, food and chemical industries.

The overall range currently includes about 40000 standard products as well as numerous special and system solutions according to customer's specifications or based on our in-house development.

All STAUFF products undergo relevant testing in accordance with international regulations and are governed by the high standards of the in-house quality management system. Furthermore, many items have received certifications and approvals from various international institutes, organisations and authorities who have independently confirmed the quality and performance of the products.

Wholly-owned manufacturing, sales and service facilities in 18 countries and a tight global network of authorised distribution partner ensure high presence and service paired with a maximum of availability.



Quality Management – ISO 9001:2015
Environmental Management – ISO 14001:2015
Safety Management OHSAS – 18001:2007

STAUFF LINE Components

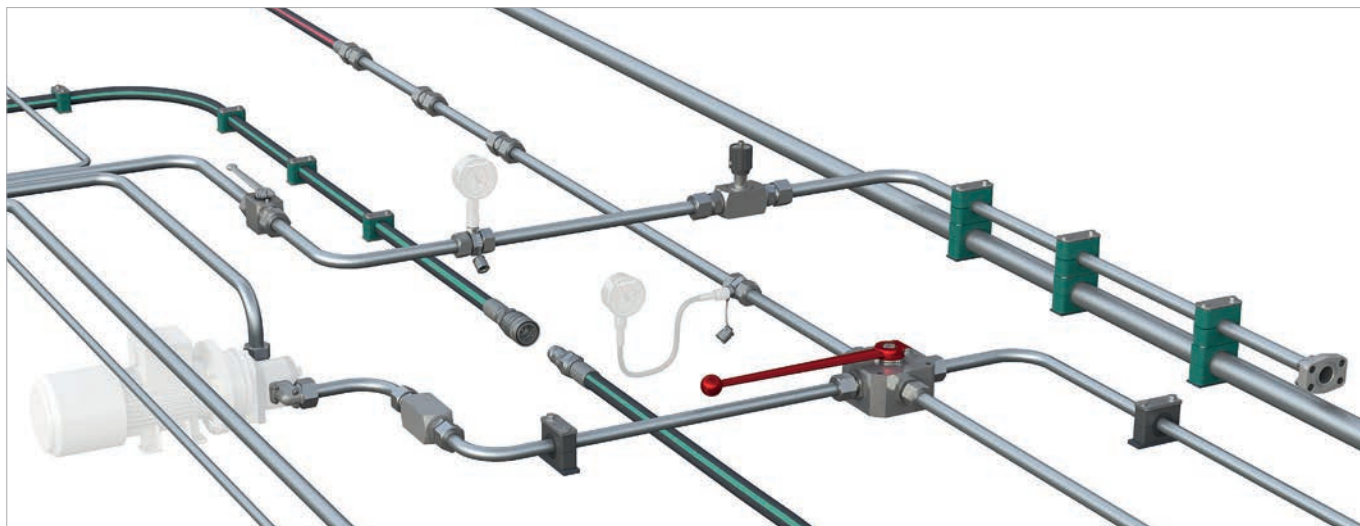

With the seven dedicated **STAUFF Line** product groups

- **STAUFF Clamps**
- **STAUFF Connect**
- **STAUFF Flanges**
- **VOSWINKEL Hose Connectors**
- **VOSWINKEL Quick Release Couplings**
- **STAUFF Valves**
- **STAUFF Test**

from own, in-house development and manufacturing, the companies of the STAUFF Group provide a comprehensive range of components for fastening and connecting pipes, tubes and hoses for mobile and industrial hydraulic applications and many other industries.

The portfolio is completed by components for shutting-off, regulating, throttling and measuring fluid media.

In order to perfectly match each other, STAUFF Line products are designed and offered on a high, uniform level of quality. A large proportion of the range made from steel comes as standard with the premium STAUFF Zinc/Nickel surface coating, which is also optionally available for many of the other components.

This coating offers the most reliable surface protection far beyond the previous market standards – even after transport, handling and assembly of the components – and meets all current legal requirements.

If desired, Original Equipment Manufacturers can be supported with value-added services, from **technical consultation to pre-assembly, assembly and kitting** as well as **logistics services**:

- Support with the **selection of suitable standard components** and ordering options; provision of **customised solutions** according to customer's specifications or based on our in-house development – from prototyping to large scale production
- **Analysis and optimization** of existing and design and developments of new systems aimed at increasing the efficiency and performance of machines and equipment and creating value for customers by reducing the total cost
- **Pre-assembly, assembly and kitting** of individual components to customer-specific system modules
- Individually coordinated **procurement solutions** (e.g. web shop and electronic data interchange) and **supply models** (e.g. from warehousing of customised components to Kanban logistics and just-in-time delivery of pre-fabricated system modules to the assembly lines of the customers) aimed at optimising material flows



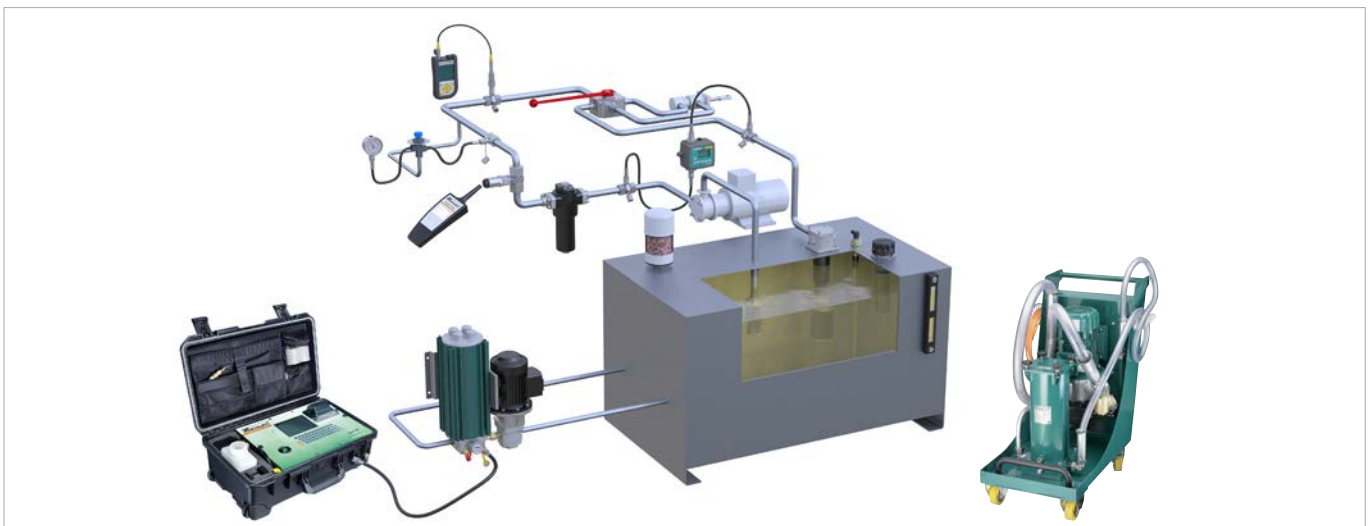

Aligned with the needs of the market, the product groups

- **STAUFF Test**
- **STAUFF Diagtronics**
- **STAUFF Filtration Technology**
- **STAUFF Hydraulic Accessories**

include a comprehensive range of analogue and digital measuring equipment and devices, filtration systems and replacement filter elements as well as accessories for the construction of tanks, reservoirs, power packs and gear boxes in mobile and industrial hydraulics.

The offer is completed by relevant value-added services:

- Support with the **selection of suitable components** and ordering options; provision of **customised solutions** according to customer's specifications or based on our in-house development – from prototyping to large scale production
- Analysis of existing hydraulic circuits aimed at filtration systems, tank components and monitoring devices that perfectly match to the specific requirements, and developing integrated concepts to increase the efficiency and performance of machines and equipment
- Individually coordinated **procurement solutions** and **supply models**





STAUFF Hydraulic Accessories

The consistently developed and enhanced STAUFF Hydraulic Accessories product range contains of well thought-out and sophisticated components suited to meet or exceed the increasing requirements of designing and building tanks, reservoirs, power packs and gear boxes for industrial and mobile hydraulic applications.

Whether you require visual or visual/electrical fluid level and temperature indicators, tank filler breathers in a variety of designs made of plastic or metal, or desiccant air breathers to protect your reservoir from contamination and moisture: STAUFF Hydraulic Accessories will provide you with the product you need.

The programme is completed by suction strainers and diffusers that are positioned within the reservoir and connected directly to the suction and return lines.

For challenging applications, STAUFF is able to provide technically modified product versions, which, for example, convince with their outstanding resistance to external influences (such as high or low temperatures, aggressive media or UV exposure) or their compact and light-weight design.

STAUFF guarantees prompt service, even for customised solutions according to customer's specifications or based on our in-house development.







www.stauff.com/catalogues

The STAUFF online catalogue centre at www.stauff.com/catalogues provides fast and direct access to digital versions of this as well as other STAUFF product catalogues in all available languages.

Online Page-Flip Catalogues

- Easy navigation through index or the powerful full text search functionality
- Contents can be shared and forwarded by e-mail, printed or downloaded and saved in PDF file format
- Also suitable for mobile devices

Download Catalogues

- Download entire product catalogues and save them in PDF file format

Catalogue Request

- Contact form to request printed copies of the product catalogue as well as digital copies on CD-ROM or USB stick

The fastest way to the online page-flip catalogue:

The links that can be found at the bottom edge of all pages of this product catalogue will lead you directly to the corresponding page in the online page-flip catalogue.

In doing so, contents can be searched, shared and forwarded by e-mail, printed or downloaded and saved in PDF file format.

Scan the QR code next to the direct link with the camera of your mobile device* and also use the functions in this way.

* may require a suitable app





www.stauff.com

General information about the companies of STAUFF Group, latest business and product news as well as complete global contact details

www.stauff.com/cad

Immediate access to and free download of 3D models and 2D drawings for a growing number of STAUFF products

www.filterinterchange.com











Online database for the quick and easy identification and interchange of almost all common brands and types of replacement filter elements

Follow STAUFF and keep yourself updated:

- Facebook**
www.facebook.com/stauffgroup
- Twitter**
www.twitter.com/stauffgroup
- LinkedIn**
www.linkedin.com/company/stauff
- Youtube**
www.youtube.com/stauffgroup





	Level Gauge	14 - 17
	SNA	14
	SNA/SNK (Special Options)	15
	SNK	16
	SNKK	17
	Accessories / Options	18 - 21
	Thermo Switch	18
	TS	
	Dial Thermometer with Probe	18
	T1 / T2	
	Temperature Sensor	19
	TS-SNA / SNK-PT100	
	Temperature Sensor with Direct Installation Set	19
	TS-SNA / SNK-PT100-T	
	Anti-Drain Valve	20
	SDV-SNA / SNK	
	Deutsch Adaptor Cable	20
	DT04-4P	
	Level-Temperature Switch	21
	SLTS	

Level Gauge Type SNA

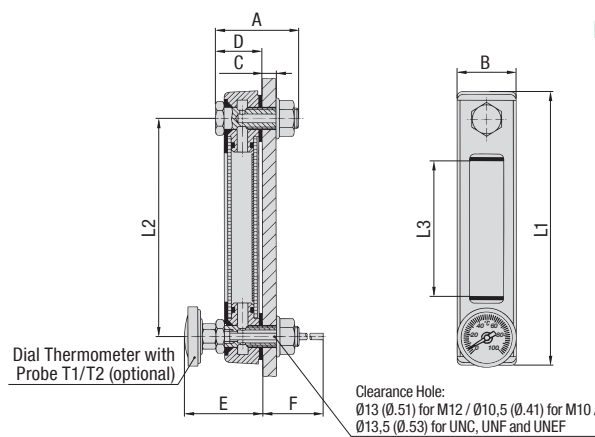

Design of Scale Plates Thermometer Options

Capillary Tube Thermometer with a dual Celsius / Fahrenheit scale up to +80 °C / +180 °F

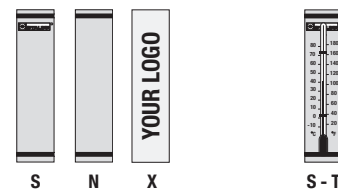

Characteristics

Visual fluid level indication in hydraulic reservoirs with maximum tank pressures not exceeding 2 bar / 29PSI

Nominal Sizes and Designs

- 7 nominal sizes from 76 mm / 2.99 in to 381 mm / 15.00 in
- Display either undivided (SNA-076 ... 176) or subdivided by strut(s) into 2 (SNA-254) or 3 sections (SNA-305 and SNA-381)

Please see page 15 for alternative nominal sizes and designs.

Media Compatibility

- Suitable for use with mineral and petroleum based hydraulic fluids (HL and HLP)

Materials

- Housing made of Steel St 12, black powder-coated
- Sight tube and plugs made of Polyamide (PA)
- Sealings made of NBR (Buna-N®)
- Scale plate made of PVC

For the individual components of the level gauge (sight glass, housing, sealings, bolts), alternative materials for improved UV or chemical resistance, low-temperature applications down to -50 °C / -58 °F and use with special media (such as bio-degradable fluids, diesel oils, gasolines) are available on request.

Technical Data

- IP 65 protection rating: Dust tight and protected against water jets
- Operating temperature range: -30 °C ... +80 °C / -22 °F ... +176 °F
- Recommended tightening torque: 8 N·m / 5.9 ft·lb

Accessories / Options

- Red / blue capillary tube thermometers with a temperature display range of up to +80 °C / +180 °F
- Dial thermometers with probe and a Celsius or a dual Celsius / Fahrenheit scale with a temperature display range of up to +100 °C / +200 °F
- Thermo Switches
- Temperature Sensors
- Floating Ball
- Deutsch Adaptor Cable

Please see pages 18 / 19 / 20 for details.

Dimensions

Maximum admissible tolerance for the bolt center spacing (dimension L2) according to DIN ISO 2768-f: ±0,20 mm / .008 in for all nominal sizes.

Nominal Size	Dimensions (mm/in)									
	A	B	C (Max.)	D	E	F (with T1)	F (with T2)	L1	L2	L3
SNA-076	45	34,5	8	28	43,5	165,5	265,5	108	76	31
	1.77	1.36	.32	1.10	1.71	6.52	10.45	4.25	2.99	1.22
SNA-127	45	34,5	8	28	43,5	165,5	265,5	159	127	76
	1.77	1.36	.32	1.10	1.71	6.52	10.45	6.26	5.00	2.99
SNA-150	45	34,5	8	28	43,5	165,5	265,5	182	150	99
	1.77	1.36	.32	1.10	1.71	6.52	10.45	7.17	5.91	3.90
SNA-176	45	34,5	8	28	43,5	165,5	265,5	208	176	124
	1.77	1.36	.32	1.10	1.71	6.52	10.45	8.19	6.93	4.88
SNA-254	45	34,5	8	28	43,5	165,5	265,5	286	254	192
	1.77	1.36	.32	1.10	1.71	6.52	10.45	11.26	10.00	7.56
SNA-305	45	34,5	8	28	43,5	165,5	265,5	337	305	244
	1.77	1.36	.32	1.10	1.71	6.52	10.45	13.27	12.00	9.61
SNA-381	45	34,5	8	28	43,5	165,5	265,5	413	381	319
	1.77	1.36	.32	1.10	1.71	6.52	10.45	16	15	12.56

Order Codes

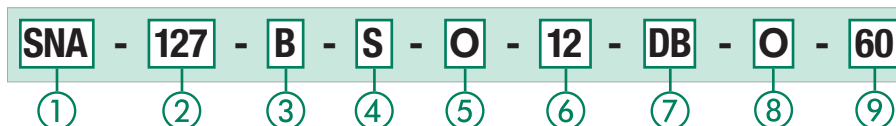

1 Type

Level Gauge with visual fluid level indication **SNA**

2 Nominal Size

SNA-076 (nominal size of 76 mm / 2.99 in)	076
SNA-127 (nominal size of 127 mm / 5.00 in)	127
SNA-150 (nominal size of 150 mm / 5.91 in)	150
SNA-176 (nominal size of 176 mm / 6.93 in)	176
SNA-254 (nominal size of 254 mm / 10.00 in)	254
SNA-305 (nominal size of 305 mm / 12.00 in)	305
SNA-381 (nominal size of 381 mm / 15.00 in)	381

Please see page 15 for alternative nominal sizes.

3 Sealing Material

NBR (Buna-N®) (standard option)	B
FKM/FPM (Viton®)	V

4 Design of Scale Plate

With STAUFF logo (standard option)	S
Neutral design without any logo	N
Custom-designed scale plate (please specify)	X

5 Thermometer Option

Supplied without thermometer (standard option)	O
Red Capillary Tube thermometer on scale plate	T
Blue Capillary Tube thermometer on scale plate	TB
Dial thermometer with probe (200 mm / 7.87 in) and a Celsius scale up to 100 °C	T1C
Dial thermometer with probe (300 mm / 11.81 in) and a Celsius scale up to 100 °C	T2C
Dial thermometer with probe (200 mm / 7.87 in) and a dual scale up to 100 °C / 200 °F	T1CF
Dial thermometer with probe (300 mm / 11.81 in) and a dual scale up to 100 °C / 200 °F	T2CF

6 Banjo Bolt Size

Metric ISO thread M12 (standard option)	12
Metric ISO thread M10	10
Unified coarse thread 1/2-13 UNC	U1
Unified fine thread 1/2-20 UNF	U2
Unified extra-fine thread 1/2-28 UNEF	U3

7 Anti-Drain Valve Option

without (standard option)	O
Set A	DA
Set B	DB

Please see page 20 for details.

8 Thermo Switch / Temperature Sensor Option

Supplied without Thermo Switch / Temperature Sensor - Thermo Switch TS-SNA/SNK; Break contact (normally closed); Equipped with standard connector	O
Thermo Switch TS-SNA/SNK; Break contact (normally closed); Equipped with connector M12	OD
Thermo Switch TS-SNA/SNK; Make contact (normally open); Equipped with standard connector	C
Thermo Switch TS-SNA/SNK; Make contact (normally open); Equipped with connector M12	CD
Temperature Sensor TS-SNA/SNK-PT100; Equipped with connector M12	PT100

Thermo Switches / Temperature Sensors only available for banjo bolt size M12. Please see pages 18 and 19 for details.

9 Switching Temperature

Contact switches at +60 °C / +140 °F	60
Contact switches at +70 °C / +158 °F	70
Contact switches at +80 °C / +176 °F	80
Contact switches at +90 °C / +194 °F	90

Only to be indicated when using a Thermo Switch.

Options T1C/CF and T2C/CF are not available for banjo bolt size M10 and not be used in conjunction with Thermo Switches or Temperature Sensors. Please see page 18 for details.



Characteristics

Visual fluid level indication in hydraulic reservoirs with maximum tank pressures not exceeding 2 bar / 29 PSI; ideal for custom applications in terms of reservoir capacities and dimensions

Nominal Sizes

- Special sizes beyond the normal of 305 mm / 12 in up to a maximum nominal size of 950 mm / 37.4 in – even for small and medium quantities
- High-precision manufacturing within 1 mm tolerance to customer requirements

Design

- Robust design thanks to one or more struts that subdivide the display into 2 or more sections
- Positioning of the strut(s) based on engineering considerations and/or according to particular customer requirements
- Precise visual indication of the fluid level by use of scale plates (only available for nominal sizes smaller than 670 mm / 26.4 in) or by use of a coloured Floating Ball (recommended option for nominal sizes larger than 670 mm / 26.4 in)

- Plastic dampening clips to reduce vibration of the sight tube are used for nominal sizes larger than 450 mm / 17.7 in

Materials

Depending on the specific application, several different materials are available for the individual components of the level gauge (sight glass, housing, sealings, bolts); please see Inquiry Checklist for details.

STAUFF is always at your service if you need support in choosing the right materials or material combination for improved UV or chemical resistance or for low-temperature applications down to -50°C / -58 °F and use with special media (such as bio-degradable fluids, diesel oils, gasolines).

Inquiry Checklist

In case that you require a special property or custom-designed level gauge, please use this checklist to provide us with details. If necessary, please also include further details, like the type of fluid in use, its temperature and viscosity.

Nominal Size

Bolt centre distance (in mm)

Housing Material

Aluminium Steel Stainless Steel

Housing Design

Regular housing design with positioning of strut(s) based on engineering considerations

Please provide additional details / drawing for custom housing designs.

Banjo Bolt Size

M12 M10 1/2–13 UNC

1/2–20 UNF 1/2–28 UNEF

Banjo Bolt Material

Steel Stainless Steel

Sealing Material

NBR (Buna-N®) FKM/FPM (Viton®) EPDM

Alternative sealing materials to be defined separately.

Level Indication

Scale plate (only for nominal sizes smaller than 382 mm / 15.03 in)

- Scale plate made of PVC With STAUFF logo
- Scale plate made of Aluminium Neutral design without any logo
- Custom-design (please specify)

- Without thermometer on scale plate
- Capillary tube thermometer with dual Celsius / Fahrenheit scale up to +80 °C / +180 °F

Floating Ball (recommended option for nominal sizes larger than 381 mm / 15.0 in)

Other types of level indication (magnetic floats, etc.) to be defined separately.

Options

Dial thermometer with probe

- Celsius scale up to +100 °C Length of probe: 200 mm / 7.87 in
- Dual scale up to +100 °C / +200 °F Length of probe: 300 mm / 11.81 in

Thermo Switch TS-SNA/SNK

- Break contact; Standard connector Contact switches at +60 °C / +140 °F
- Break contact; Connector M12 Contact switches at +70 °C / +158 °F
- Make contact; Standard connector Contact switches at +80 °C / +176 °F
- Make contact; Connector M12 Contact switches at +90 °C / +194 °F

Temperature Sensor TS-SNA/SNK-PT100 Deutsch Adaptor Cable

Anti-Drain Valve Set A Set B

Level Gauge (Special Options) Type SNA/SNK

Accessories / Options

- Red / blue capillary tube thermometers with a temperature display range of up to +80 °C / +180 °F
- Dial thermometers with probe and a Celsius or a dual Celsius / Fahrenheit scale with a temperature display range of up to +100 °C / +200 °F
- Thermo switches
- Temperature sensors
- Anti-Drain Valve
- Deutsch Adaptor Cable

Please see pages 18 / 19 / 20 for details.



Also available:

Level Gauges - Type SNK in Special Lengths

Visual / electrical fluid level indication in hydraulic reservoirs with level gauges up to a maximum nominal size of 950 mm / 37.4 in.

Please do not hesitate to contact STAUFF for further details.



Level Gauge Type SNK

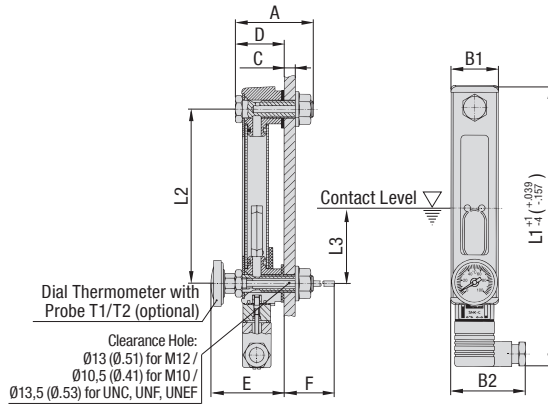

Connection Details and Electrical Functions

Types C and O: Industrial standard connector (contact gap: 11 mm / .43in), similar to DIN EN 175301-803-B / ISO 6952

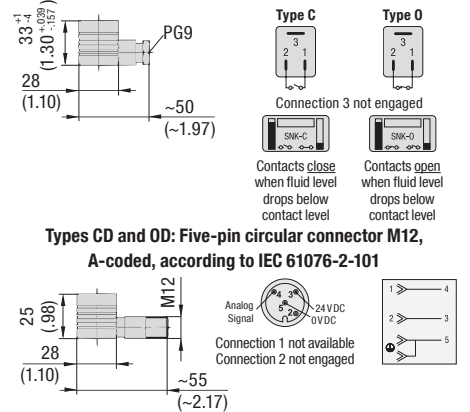

Characteristics

Visual / electrical fluid level indication in hydraulic reservoirs with maximum tank pressures not exceeding 2 bar / 29 PSI

Nominal Sizes and Designs

- 6 nominal sizes from 127 mm / 5.00 in to 381 mm / 15.00 in
- Display either undivided (SNK-127 ... 176) or subdivided by strut(s) into 2 (SNK-254) or 3 sections (SNK-305 and SNK-381)

Media Compatibility

- Suitable for use with mineral and petroleum based hydraulic fluids (HL and HLP)

Materials

- Housing made of Aluminium, black powder-coated
- Sight tube and plugs made of Polyamide (PA)
- Float made of Polyamide (PA)
- Sealings made of FKM/FPM (Viton®)

For the individual components of the level gauge (sight glass, housing, sealings, bolts), alternative materials for improved UV or chemical resistance, low-temperature applications down to -50°C / -58 °F and use with special media (such as bio-degradable fluids, diesel oils, gasolines) are available on request.

Electrical Specifications

- Magnetic float activates switch when fluid level drops below contact level within 60 mm / 2.36 in of lower banjo bolt
- Available as a break contact (normally closed) or make contact (normally open)
- Either equipped with industrial standard connector (types C / O) or five-pin circular connector M12 (types CD / OD)
- Direction of the electrical contact box (right / left) can be chosen when assembling the electrical contacts (types C / D) or is right by default (types CD / OD)
- Contact ratings: max. 10W (types C / CD) or 5W (types O / OD)
- Switching voltage: max. 50VAC/DC
- Switching current: max. 0,25 A

Technical Data

- IP 65 protection rating: Dust tight and protected against water jets (IP 67 on request)
- Operating temperature range: -30°C ... +80°C / -22°F ... +176°F
- Recommended tightening torque: 8N·m / 5.9ft·lb
- Minimum lateral distance to other magnetic components and cables: 10 mm / .39 in

Accessories / Options

- Dial thermometers with probe and a Celsius or a dual Celsius / Fahrenheit scale with a temperature display range of up to +100°C / +200°F
 - Thermo Switches
 - Temperature Sensors
 - Deutsch Adaptor Cable
- Please see pages 18 / 19 / 20 for details.

Dimensional drawings: All dimensions in mm (in).

Dimensions

Maximum admissible tolerance for the bolt center spacing (dimension L2) according to DIN ISO 2768-f: ±0,20mm / .008in for all nominal sizes.

Nominal Size	Dimensions (mm/in)										
	A	B1	B2	C (Max.)	D	E	F (with T1)	F (with T2)	L1	L2	L3
SNK-127	56	34,5	~50	8	35,1	51,5	157,5	257,5	205	127	~60
SNK-150	2.20	1.36	~1.97	.32	1.26	2.03	6.20	10.14	8.07	5.00	~2.36
SNK-176	56	34,5	~50	8	35,1	51,5	157,5	257,5	228	150	~60
SNK-176	2.20	1.36	~1.97	.32	1.26	2.03	6.20	10.14	8.98	5.91	~2.36
SNK-254	56	34,5	~50	8	35,1	51,5	157,5	257,5	254	176	~60
SNK-254	2.20	1.36	~1.97	.32	1.26	2.03	6.20	10.14	10.00	6.93	~2.36
SNK-305	56	34,5	~50	8	35,1	51,5	157,5	257,5	332	254	~60
SNK-305	2.20	1.36	~1.97	.32	1.26	2.03	6.20	10.14	13.07	10.00	~2.36
SNK-381	45	34,5	8	28	43,5	165,5	265,5	413	459	381	~60
SNK-381	1.77	1.36	.32	1.10	1.71	6.52	10.45	16	18.07	15	~2.36

Order Codes

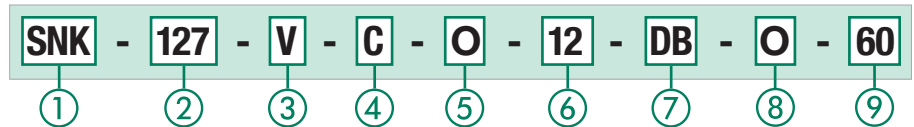

1 Type

Level Gauge with visual / electrical fluid level indication **SNK**

2 Nominal Size

SNK-127 (nominal size of 127 mm / 5.00 in) **127**
 SNK-150 (nominal size of 150 mm / 5.91 in) **150**
 SNK-176 (nominal size of 176 mm / 6.93 in) **176**
 SNK-254 (nominal size of 254 mm / 10.00 in) **254**
 SNK-305 (nominal size of 305 mm / 12.00 in) **305**
 SNK-381 (nominal size of 381 mm / 15.00 in) **381**
 Contact STAUFF for alternative nominal sizes and designs.

3 Sealing Material

FKM/FPM (Viton®) **V**

4 Electrical Function

Break contact, opens at contact level (normally closed); Equipped with standard connector **O**
 Break contact, opens at contact level (normally closed); Equipped with connector M12 **OD**
 Make contact, closes at contact level (normally open); Equipped with standard connector **C**
 Make contact, closes at contact level (normally open); Equipped with connector M12 **CD**

5 Thermometer Option

Supplied without thermometer (standard option) **O**
 Dial thermometer with probe (200 mm / 7.87 in) and a Celsius scale up to 100°C **T1C**
 Dial thermometer with probe (300 mm / 11.81 in) and a Celsius scale up to 100°C **T2C**
 Dial thermometer with probe (200 mm / 7.87 in) and a dual scale up to 100°C / 200°F **T1CF**
 Dial thermometer with probe (300 mm / 11.81 in) and a dual scale up to 100°C / 200°F **T2CF**

6 Banjo Bolt Size

Metric ISO thread M12 (standard option) **12**
 Metric ISO thread M10 **10**
 Unified coarse thread 1/2-13 UNC **U1**
 Unified fine thread 1/2-20 UNF **U2**
 Unified extra-fine thread 1/2-28 UNEF **U3**

7 Anti-Drain Valve Option

without (standard option) **O**
 Set A **DA**
 Set B **DB**
 Please see page 20 for details.

8 Thermo Switch / Temperature Sensor Option

Supplied without Thermo Switch / Temperature Sensor - Thermo Switch TS-SNA/SNK; Break contact (normally closed); Equipped with standard connector **O**
 Thermo Switch TS-SNA/SNK; Break contact (normally closed); Equipped with connector M12 **OD**
 Thermo Switch TS-SNA/SNK; Make contact (normally open); Equipped with standard connector **C**
 Thermo Switch TS-SNA/SNK; Make contact (normally open); Equipped with connector M12 **CD**
 Temperature Sensor TS-SNA/SNK-PT100; Equipped with connector M12 **PT100**
 Thermo Switches / Temperature Sensors only available for banjo bolt size M12. Please see pages 18 and 19 for details.

9 Switching Temperature

Contact switches at +60°C / +140°F **60**
 Contact switches at +70°C / +158°F **70**
 Contact switches at +80°C / +176°F **80**
 Contact switches at +90°C / +194°F **90**
 Only to be indicated when using a Thermo Switch.

Options T1C/CF and T2C/CF are not available for banjo bolt size M10 and not be used in conjunction with Thermo Switches or Temperature Sensors. Please see page 18 for details.



Connection Details and Electrical Functions

Type DD: Five-pin circular connector M12, A-coded, according to IEC 61076-2-101

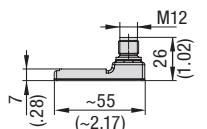

1 Contact opens and 1 contact closes when fluid level drops below contact level

Pin assignment at empty reservoir (default setting at point of delivery)



Dial Thermometer with Probe T1/T2 (optional)

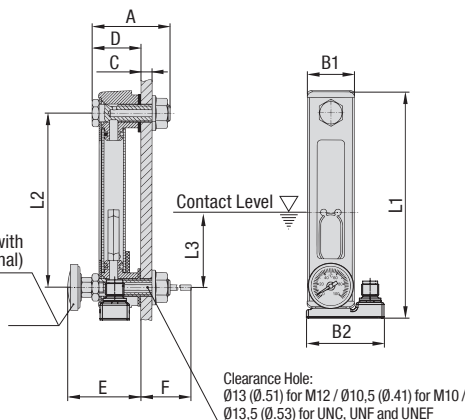

Clearance Hole: $\varnothing 13$ (0.51) for M12 / $\varnothing 10,5$ (0.41) for M10 / $\varnothing 13,5$ (0.53) for UNC, UNF and UNEF

Level Gauge (Compact Design) Type SNKK



~40mm / ~1.57in in comparison with Level Gauges SNK

Dimensions

Maximum admissible tolerance for the bolt center spacing (dimension L2) according to DIN ISO 2768-f: $\pm 0,20$ mm / .008in for all nominal sizes.

Nominal Size	Dimensions (mm/in)										
	A	B1	B2	C (Max.)	D	E	F (with T1)	F (with T2)	L1	L2	L3
SNKK-127	56	34,5	~55	8	35,1	51,5	157,5	257,5	165	127	~60
	2.20	1.36	~2.17	.32	1.26	2.03	6.20	10.14	6.50	5.00	~2.36
SNKK-150	56	34,5	~50	8	35,1	51,5	157,5	257,5	188	150	~60
	2.20	1.36	~1.97	.32	1.26	2.03	6.20	10.14	8.98	5.91	~2.36
SNKK-176	56	34,5	~55	8	35,1	51,5	157,5	257,5	214	176	~60
	2.20	1.36	~2.17	.32	1.26	2.03	6.20	10.14	8.43	6.93	~2.36
SNKK-254	56	34,5	~55	8	35,1	51,5	157,5	257,5	292	254	~60
	2.20	1.36	~2.17	.32	1.26	2.03	6.20	10.14	11.50	10.00	~2.36
SNKK-305	56	34,5	~55	8	35,1	51,5	157,5	257,5	343	305	~60
	2.20	1.36	~2.17	.32	1.26	2.03	6.20	10.14	13.50	12.00	~2.36
SNKK-381	45	34,5	8	28	43,5	165,5	265,5	413	419	381	~60
	1.77	1.36	.32	1.10	1.71	6.52	10.45	16	18.07	15	~2.36

Order Codes

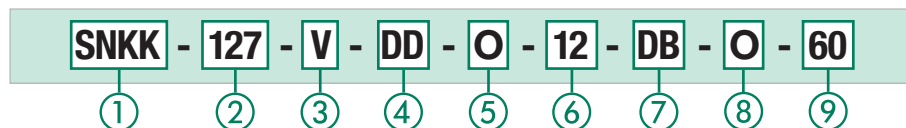

1 Type

Level Gauge with visual / electrical fluid level indication (compact design) **SNKK**

2 Nominal Size

SNKK-127 (nominal size of 127 mm / 5.00 in) **127**
 SNKK-150 (nominal size of 150 mm / 5.91 in) **150**
 SNKK-176 (nominal size of 176 mm / 6.93 in) **176**
 SNKK-254 (nominal size of 254 mm / 10.00 in) **254**
 SNKK-305 (nominal size of 305 mm / 12.00 in) **305**
 SNKK-381 (nominal size of 381 mm / 15.00 in) **381**
 Contact STAUFF for alternative nominal sizes and designs.

3 Sealing Material

FKM/FPM (Viton®) **V**

4 Electrical Function

SPDT (Single Pole Double Throw) contacts, 1 contact opens and 1 contact closes at contact level; Equipped with connector M12 **DD**

5 Thermometer Option

Supplied without thermometer (standard option) **O**
 Dial thermometer with probe (200 mm / 7.87 in) and a Celsius scale up to 100 °C **T1C**
 Dial thermometer with probe (300 mm / 11.81 in) and a Celsius scale up to 100 °C **T2C**
 Dial thermometer with probe (200 mm / 7.87 in) and a dual scale up to 100 °C / 200 °F **T1CF**
 Dial thermometer with probe (300 mm / 11.81 in) and a dual scale up to 100 °C / 200 °F **T2CF**

6 Banjo Bolt Size

Metric ISO thread M12 (standard option) **12**
 Metric ISO thread M10 **10**
 Unified coarse thread 1/2–13 UNC **U1**
 Unified fine thread 1/2–20 UNF **U2**
 Unified extra-fine thread 1/2–28 UNEF **U3**

7 Anti-Drain Valve Option

without (standard option) **O**
 Set A **DA**
 Set B **DB**
 Please see page 20 for details.

8 Thermo Switch / Temperature Sensor Option

Supplied without Thermo Switch / Temperature Sensor - Break Contact, opens at contact level (normally closed); Equipped with standard connector **O**
 Break Contact, opens at contact level (normally closed); Equipped with connector M12 **OD**
 Make Contact, closes at contact level (normally open); Equipped with standard connector **C**
 Make Contact, closes at contact level (normally open); Equipped with connector M12 **CD**
 Temperature Sensor TS-SNA/SNK-PT100; Equipped with connector M12 **PT100**
 Thermo Switches / Temperature Sensors only available for banjo bolt size M12. Please see pages 18 and 19 for details.

9 Switching Temperature

Contact switches at +60 °C / +140 °F **60**
 Contact switches at +70 °C / +158 °F **70**
 Contact switches at +80 °C / +176 °F **80**
 Contact switches at +90 °C / +194 °F **90**
 Only to be indicated when using a Thermo Switch.
 Options T1C/CF and T2C/CF are not available for banjo bolt size M10 and not be used in conjunction with Thermo Switches or Temperature Sensors.
 Please see page 18 for details.

Characteristics

Visual / electrical fluid level indication in hydraulic reservoirs with maximum tank pressures not exceeding 2 bar / 29 PSI; ideal for applications in which space is limited

Nominal Sizes and Designs

- 6 nominal sizes from 127 mm / 5.00 in to 381 mm / 15.00 in
- Compact design allows space-saving installation: Always 40 mm / 1.57 in shorter than Level Gauges SNK of the comparable nominal size
- Display either undivided (SNKK-127 ... 176) or subdivided by strut(s) into 2 (SNKK-254) or 3 sections (SNKK-305 and SNKK-381)

Media Compatibility

- Suitable for use with Mineral and Petroleum based hydraulic fluids (HL and HLP)

Materials

- Housing made of Aluminium, black powder-coated
- Sight tube and plugs made of Polyamide (PA)
- Float made of Polypropylene (PP)
- Sealings made of FKM/FPM (Viton®)

For the individual components of the level gauge (sight glass, housing, sealings, bolts), alternative materials for improved UV or chemical resistance, low-temperature applications down to -50 °C / -58 °F and use with special media (such as bio-degradable fluids, diesel oils, gasolines) are available on request.

Electrical Specifications

- Magnetic float activates switch when fluid level drops below contact level within 60 mm / 2.36 in of lower banjo bolt
- Available as a SPDT (Single Pole Double Throw) contact
- Equipped with five-pin circular connector M12 or Deutsch connector
- Direction of the electrical contact box is right to top by default

Technical Data

- IP 67 protection rating: Dust tight and protected against powerful water jets; even immersion (up to 1 m / 3.28 ft) in water is possible under defined conditions of pressure and time (IP 69K on request)
- Operating temperature range: -30 °C ... +80 °C / -22 °F ... +176 °F
- Recommended tightening torque: 8 N·m / 5.9 ft·lb
- Minimum lateral distance to other magnetic components and cables: 10 mm / .39 in

Accessories / Options

- Dial thermometers with probe and a Celsius or a dual Celsius / Fahrenheit scale with a temperature display range of up to +100 °C / +200 °F
 - Thermo Switches
 - Temperature Sensors
 - Deutsch Adaptor Cable
- Please see pages 18 / 19 / 20 for details.

Dimensional drawings: All dimensions in mm (in).



Thermo Switch Type TS

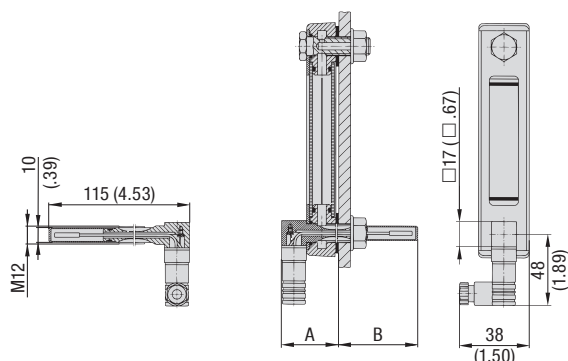

Connection Details and Electrical Functions

Types C and O: Industrial standard connector (contact gap: 9,4 mm / .37in), similar to DIN EN 175301-803-C / ISO 6952

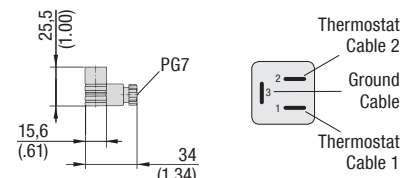

Types CD and OD: Five-pin circular connector M12, A-coded, according to IEC 61076-2-101

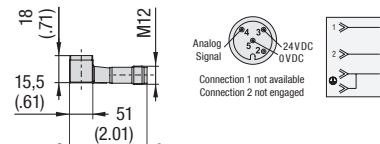

Characteristics

Fluid temperature measurement in conjunction with STAUFF Level Gauges SNA, SNK and SNKK

Installation

- Replaces the lower banjo bolt of the Level Gauge
- Available for bolt size M12 only
- Clearance hole: $\varnothing 13$ mm / $\varnothing .51$ in

Materials

- Metal parts made of Steel (1.0718)
- Plastic parts made of glass-fibre reinforced Polyamide (PA)

Electrical Specifications (General)

- Thermo switch is activated when the fluid temperature reaches the respective switching temperature
- Available with switching temperatures of $+60$ °C / $+140$ °F, $+70$ °C / $+158$ °F, $+80$ °C / $+176$ °F or $+90$ °C / $+194$ °F (with a switching tolerance of ± 5 °C / ± 9 °F and a hysteresis of 35 °C / 63 °F)
- Available as a break contact (normally closed) or make contact (normally open)
- Either equipped with industrial standard connector (types C / O) or five-pin circular connector M12 (types CD / OD)
- Thermo switch can be rotated by 360° to its final direction

Dimensions

	Dimensions (mm/in)	
	A	B
In conjunction with Level Gauge SNA	39	76
In conjunction with Level Gauge SNK	47	68
In conjunction with Level Gauge SNKK	47	68

Electrical Specifications (Alternating Current)

- Maximum voltage: 250 V, 2,5 (1,6) A, 50 Hz
- Maximum current at 2000 operations: 4,0 A at $\cos \varphi = 4,45 / 250$ V, 135 °C
- Maximum current at 10000 operations: 2,5 A at $\cos \varphi = 1,00 / 250$ V, 150 °C
- Minimum current: 20 mA

Electrical Specifications (Direct Current)

- Maximum voltage: 42 V

Accessories / Options

- Deutsch Adaptor Cable
- Please see page 20 for details.

Order Codes



① Type

Thermo Switch TS for use with Level Gauges SNA, SNK and SNKK **TS-SNA/SNK**

② Electrical Function

- Break contact, opens at switching temperature (normally closed); Equipped with standard connector **O**
- Break contact, opens at switching temperature (normally closed); Equipped with connector M12 **OD**
- Make contact, closes at switching temperature (normally open); Equipped with standard connector **C**
- Make contact, closes at switching temperature (normally open); Equipped with connector M12 **CD**

③ Switching Temperature

- Contact switches at $+60$ °C / $+140$ °F **60**
- Contact switches at $+70$ °C / $+158$ °F **70**
- Contact switches at $+80$ °C / $+176$ °F **80**
- Contact switches at $+90$ °C / $+194$ °F **90**

Dial Thermometer with Probe Types T1/T2

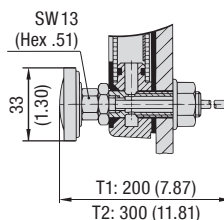

Characteristics

Visual fluid temperature measurement in conjunction with STAUFF Level Gauges SNA, SNK and SNKK

Nominal Sizes and Designs

- Probe lengths of 200 mm / 7.87 in or 300 mm / 11.81 in
- Scale diameter of 33 mm / 1.30 in

Please contact STAUFF for special versions.

Scale Options

- Celsius scale of $0^\circ\text{C} \dots +100^\circ\text{C}$
- Dual Celsius / Fahrenheit scale of up to $+100^\circ\text{C} / +200^\circ\text{F}$

Materials

- Probe made of Stainless Steel V4A (1.4571)

Technical Data

- IP 65 protection rating: Dust tight and protected against water jets

Installation

- Requires a special banjo bolt (with internal M8 port for the dial thermometer with probe) to replace the lower standard banjo bolt of the Level Gauge
- Use suitable wrench SW 13 (Hex .51) to fasten; turning on the body itself may damage the product

Please note that Dial Thermometers with Probe can only be ordered in conjunction with Level Gauges SNA, SNK and SNKK. Please see page 14 to 17 for details.

Dimensional drawings: All dimensions in mm (in).



Connection Details and Electrical Functions

Four-pin circular connector M12, A-coded, according to IEC 61076-2-101

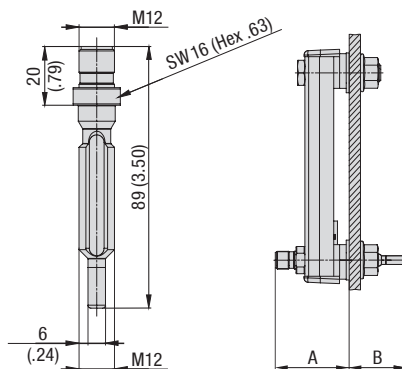
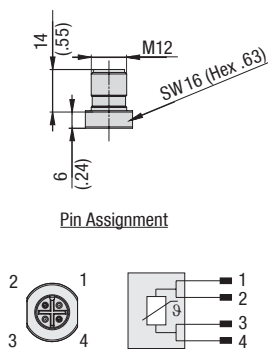
 Temperature Sensor
Type TS-SNA/SNK-PT100

A

Order Codes

TS-SNA/SNK-PT100

①

① Type

 Temperature Sensor PT100 **TS-SNA/SNK-PT100**

Dimensions

	Dimensions (mm/in)	
	A	B
In conjunction with Level Gauge SNA	43,5 1.71	45,5 1.79
In conjunction with Level Gauge SNK	51 2.01	38 1.50
In conjunction with Level Gauge SNKK	51 2.01	38 1.50

Characteristics

Fluid temperature measurement in conjunction with STAUFF Level Gauges SNA, SNK and SNKK; Analysis of signals with required equipment, simply connect to your on board control unit or PLC.

Installation

- Replaces the lower banjo bolt of the Level Gauge
- Available for bolt size M12 only
- Clearance hole: $\varnothing 13$ mm / $\varnothing .51$ in

Materials

- Metal parts (including all fluid-affected parts) made of Stainless Steel V2A (1.4305)

Electrical Specifications

- Measuring temperature range: $-40^{\circ}\text{C} \dots +150^{\circ}\text{C}$ / $-40^{\circ}\text{F} \dots +302^{\circ}\text{F}$
- Platinum measuring element PT100 according to DIN EN 60751, class A
- Accuracy: $\pm(0,15 \text{ K} + 0,002 \times |t|)$
- Max. contact current: 2,0 mA
- Equipped with four-pin circular connector M12 with gold-plated contacts

Technical Data

- Operating temperature range (for the connector area): $-25^{\circ}\text{C} \dots +80^{\circ}\text{C}$ / $-13^{\circ}\text{F} \dots +176^{\circ}\text{F}$
- IP 68 protection rating: Dust tight and protected against powerful water jets; even immersion (beyond 1 m / 3.28 ft) in water is possible under defined conditions of pressure and time

Accessories / Options

- Deutsch Adaptor Cable
- Please see page 20 for details.

Order Codes

TS-SNA/SNK-PT100 - T - B

①

②

③

① Type

 Temperature Sensor PT100 **TS-SNA/SNK-PT100**

② Direct Adaptor

Direct installation set including M12 screw nut, gasket, front ring and O-ring

T

③ Sealing Material

NBR (Buna-N®) (standard option) **B**
FKM/FPM (Viton®) **V**
EPDM **E**

The direct installation set can also be used in conjunction with Thermo Switches TS (see page 18). Please contact STAUFF for further information.

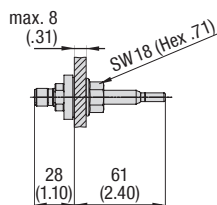
 Temperature Sensor with Direct Installation Set
Type TS-SNA/SNK-PT100-T

Materials

- Fluid-affected parts made of Stainless Steel V2A (1.4305)
- M12 screw nut made of Steel, zinc-plated
- Front ring made of Stainless Steel V2A (1.4305)
- O-ring and gasket made of NBR (Buna-N®) (standard option), FKM/FPM (Viton®) or EPDM

Please see top of this page for Technical Details and Electrical Specifications for the Temperature Sensor.

Accessories / Options

- Deutsch Adaptor Cable
- Please see page 20 for details.

Characteristics

Direct fluid temperature measurement without STAUFF Level Gauges SNA, SNK and SNKK; Analysis of signals with required equipment, simply connect to your on board control unit or PLC.

Installation

- Direct installation to the outer wall of the hydraulic reservoir or gearbox
- Compact design and easy installation
- Clearance hole: $\varnothing 13$ mm / $\varnothing .51$ in



Anti-Drain Valve Type SDV-SNA/SNK

A

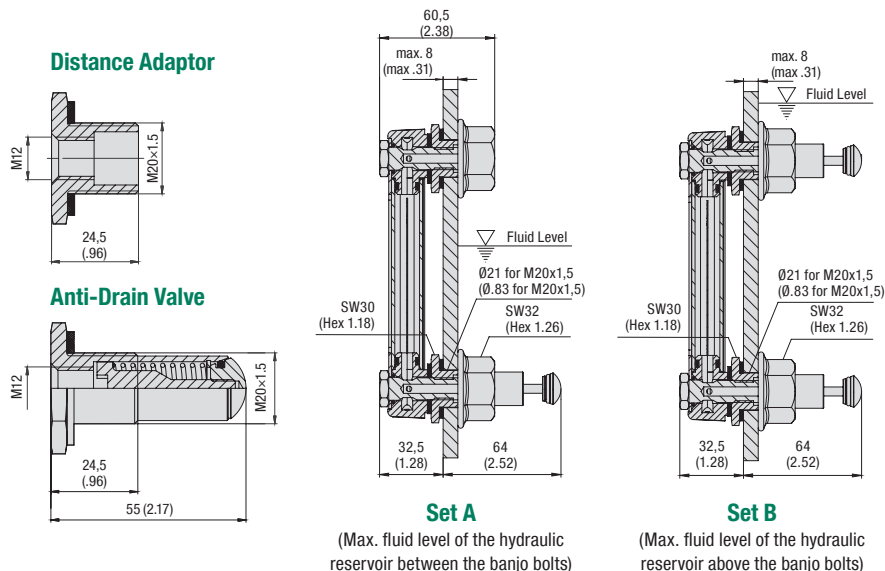

Characteristics

Anti-drain valve to be used in conjunction with banjo bolts of level gauges, allowing these to be removed and replaced quickly and easily without spillage of fluid from the hydraulic reservoir

Features

- Used in conjunction with either the lower or both the lower and the upper banjo bolts of the Level Gauge
- Distance adaptor for the upper banjo bolt available when the check valve is used with the lower banjo bolt only
- Available for bolt size M12 only

Materials

- Housing made of Stainless Steel V2A (1.4301)
- Hexagon head nuts made of Steel, zinc/nickel-plated (Fe/Zn Ni 6)
- Sealings made of NBR (Buna-N®)

Contact STAUFF for alternative materials.

Order Codes

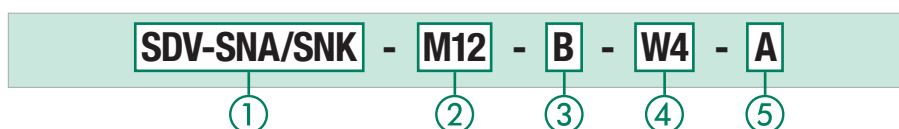

1 Type

Anti-Drain Valve for use with Level Gauges SNA, SNK and SNKK **SDV-SNA/SNK**

2 Banjo Bolt Size

Metric ISO thread M12 **M12**

3 Sealing Material

NBR (Buna-N®) **B**

4 Housing Material

Stainless Steel V2A (1.4301) **W4**

5 Set Type

Set A consisting of 1 anti-drain valve to be used with the lower banjo bolt and 1 distance adaptor to be used with the upper banjo bolt **A**
Set B consisting of 2 anti-drain valves to be used with both banjo bolts **B**

Deutsch Adaptor Cable Type DT04-4P



Characteristics

Deutsch adaptor to use for adaption from M12 to Deutsch Plug DT04-4P.

Installation

- Adapts to cable box M12 of SNK
- Adapts to M12 connector of SNKK and TS-SNA/SNK ...
- Adapts to M12 connector of TS-SNA/SNK-PT100
- Adapts to any electrical M12 connector in other Stauff series

Technical Data

- IP 68 protection rating: Dust tight and protected against powerful water jets
- Length: 100mm (3.93 in)
- Operating temperature range: -30°C ... +80°C / -22°F ... +176°F

Order Codes

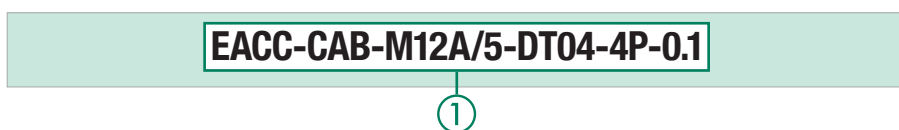

1 Type

Deutsch Adaptor Cable **EACC-CAB-M12A/5-DT04-4P-01**

Dimensional drawings: All dimensions in mm (in).



Level-Temperature Switch Type SLTS

Wiring Scheme

two level contacts
one temperature contact

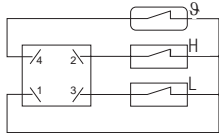

one level contact
one temperature contact

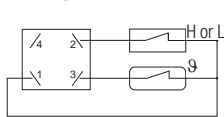

Schemes for float in low position

Pin assignment at empty reservoir (default setting at point of delivery)

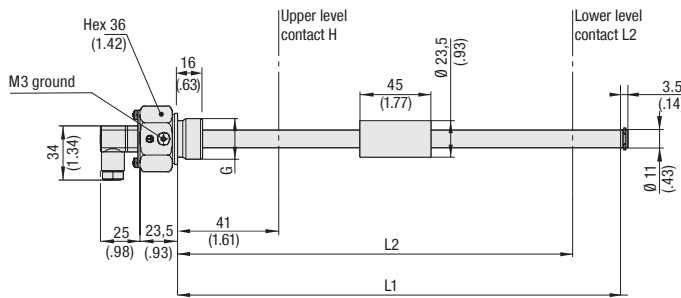

Order Codes

SLTS - 12 - O - H41 - L251 - B12 - G048 - M12

① ② ③ ④ ⑤ ⑥ ⑦ ⑧

① Series and Type

Level-Temperature Switch **SLTS**

② Stem Length

L1: 305 mm / 12 in L2: 251 mm / 9.88 in **12**
L1: 457 mm / 18 in L2: 403 mm / 15.87 in **18**

③ Switching Temperature

Without temperature switch **0**
+60 °C / +140 °F **060**
+70 °C / +158 °F **070**

④ H (Upper Level Contact)

Without upper level contact **0**
41 mm / 1.61 in **H41**

⑤ L (Lower Level Contact)

Without lower level contact **0**
251 mm / 9.88 in (SLTS-12 only) **L251**
403 mm / 15.87 in (SLTS-18 only) **L403**

⑥ Thread Connection

G3/4 (standard option) **B12**
1 NPT **N16**
Note: Others on request

⑦ Voltage (Volt AC/DC)

48 Volt max. (standard option) **G048**
115 Volt max. (for thread N16 only) **G115**

⑧ Electrical Connection

similar DIN VDE 0627 / IEC 61984 **CB**
M12 pin terminal **M12**

Characteristics

The STAUFF Level-Temperature Switches (SLTS Series) are unique in their design and modularity. One of the greatest advantages is the ability of the end-user to adjust the switching level. The internal support wire carrying the level and temperature switches makes it a simple and quick job to change the level switch position.

Level contact positions (L, H) are set as given in the order code. They can be adjusted individually later on. Please consider a minimum distance of 40 mm / 1.57 in between the switching points.

Features

- Suitable for Mineral Oil and HFC fluids, other fluids on request
- Either 1 or 2 level contacts available
- 1 integrated temperature switch (optional)
- Standard electrical function:
Level contacts: Normally closed, opens with falling level
Temperature contacts: Normally closed, opens with rising temperature

STAUFF Level-Temperature Switches SLTS are available with other electrical functions on request.

Options

- 1 NPT and others available on request
 - max. 115 Volt switching (for thread N16 only)
 - Deutsch Adaptor Cable
- Please see page 20 for details.

Materials

- Stem: Brass
- Float/Sealing: NBR (Buna-N®)

- Max. operating temp.: +80 °C / +176 °F

Electrical Data and Output

- Max. current level contact: 0.5 A
- Max. current temp. contact: 2.0 A
- Contact load level contact: 10 VA
- Max. operating voltage: (See ordering code)

- Specific gravity of fluid: $\geq 0,8 \text{ kg/dm}^3$
- Hysteresis: +18 °C / +64.4 °F

Protection Rating

- IP 65 protection rating: Dust tight and protected against water jets

Contact Life Time

Due to their design Reed contacts have a very high life expectancy. However, it is worthwhile to note the following information.

Contact Protection

To reduce the high reverse voltage produced when a reed switch opens, the following contact protection can be applied.

- DC voltage: a diode parallel to the load, see figure A
- AC voltage: a RC-network parallel to the load, see figure B and table below

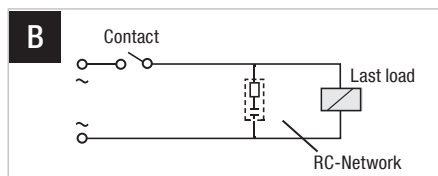
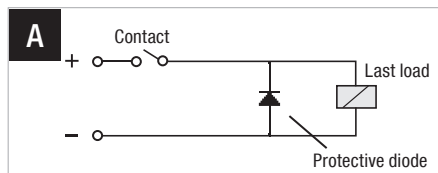

Open contact voltage V	10 VA		25 VA		50 VA		75 VA		100 VA	
	R (Ω)	C (μF)	R (Ω)	C (μF)	R (Ω)	C (μF)	R (Ω)	C (μF)	R (Ω)	C (μF)
24	22	0,022	1	0,1	1	0,47	1	1	1	1
48	120	0,0047	22	0,022	1	0,1	1	0,47	1	0,47
110	470	0,001	120	0,0047	22	22	22	0,047	22	0,1

Dimensional drawings: All dimensions in mm (in).





Plastic Filler Breather		24 - 31	Metal Filler Breather		32 - 37
	SPB-1 / 2 / 3 (Threaded Version)	24		SMBT-47 (Threaded Version)	32
	SPB-4 / 5 (Flange Version)	25		SMBB-47 (Bayonet Version)	33
Accessories / Options		26		SMBT-80 (Threaded Version)	34
Dipsticks / Baskets / Pressurisation				SMBB-80 (Bayonet Version)	35
Pressure Drop Flow Curves		27		SMBP-80 (Push-On Version)	36
	SPBN (Compact Design; Threaded Version)	28	Lockable Metal Filler Breather		37
	SPBN (Compact Design; Bayonet Version)	28	SMBL (Clamping, Threaded and Push-On Version)		
Accessories / Options / Pressure Drop Flow Curves		29	Accessories / Options		38 - 39
Dipsticks / Baskets / Pressurisation			Side Mount Bracket		38
Plastic Filler Breather Mini		30		ASMB-1 (Polyamide Version)	
	SPBM (Threaded Version)			Side Mount Bracket	38
	SES (Threaded Version)	31	ASMB-2 (Aluminium Version)		
	SES (Welded Version)	31	Extended Bayonet Flange		39
			EBF		
			Weld Riser		39
			WR		

B

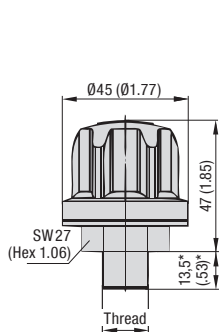

Plastic Filler Breather Types SPB-1 / 2 / 3 (Threaded Version)

B

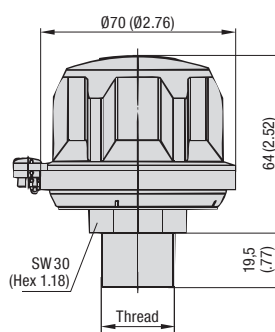

SPB-1

* for thread type N12: 16,0 (.63)



SPB-2

(See page 28 for compact version SPBN)

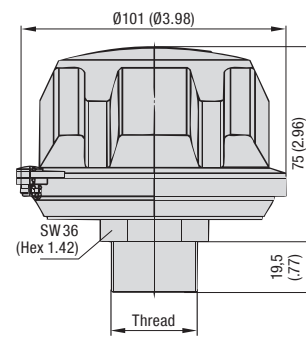

SPB-3

Characteristics

Designed to be used as filler ports for hydraulic reservoirs, allowing the reservoir to breathe whilst protecting it from contamination found in harsh environments

Features

- Available with 3 different cap diameters
- Threaded version, equipped with male BSP thread (ISO 228) or male NPT thread (ANSI B1.20.1)
- Operating temperature range: -40 °C ... +120 °C / -40 °F ... +248 °F

Materials

- Made of non-corrosive materials
- Body and cap made of glass-fibre reinforced Polyamide (PA)
- Sealings made of NBR (Buna-N®)

Contact STAUFF for alternative materials.

Accessories / Options

- Pressurisation up to 0,7 bar / 10 PSI (not available for SPB-1)
- Air filter element
- Anti-splash feature
- Plastic dipstick with integrated anti-splash feature
- Plastic dipstick with integrated magnet
- Oil Demister (not available for SPB-1)

Please see pages 26 and 47 for details.

Maximum Air Flow Rate

- 0,15 m³/min / 5.30 cfm for SPB-1
- 0,40 m³/min / 14.13 cfm for SPB-2
- 1,00 m³/min / 35.31 cfm for SPB-3

Please see page 27 for detailed air flow curves.

Installation

- Recommended mounting spaces:
 - Ø48 mm / Ø1.89 in for SPB-1,
 - Ø90 mm / Ø3.54 in for SPB-2, and
 - Ø122 mm / Ø4.80 in for SPB-3

Thread Options

Thread	SPB-1	SPB-2	SPB-3	Code
Male BSP Thread (ISO 228)				
G1/4	●	○	○	B04
G3/8	●	●	○	B06
G1/2	●	●	●	B08
G3/4	○	●	●	B12
G1	○	○	●	B16

Thread	SPB-1	SPB-2	SPB-3	Code
Male NPT Thread (ANSI B1.20.1)				
1/4	●	○	○	N04
3/8	●	○	○	N06
1/2	●	○	○	N08
3/4	●	●	●	N12
1	○	○	●	N16

● Standard Option

Order Codes

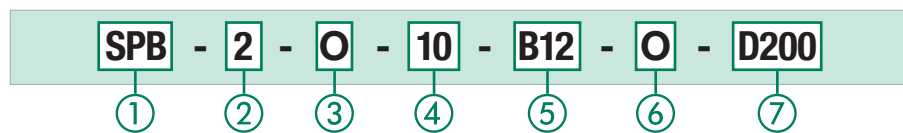

① Type

Plastic Filler Breather **SPB**

② Version

Threaded version; Cap diameter Ø45 mm (Ø1.77 in) **1**
 Threaded version; Cap diameter Ø70 mm (Ø2.76 in) **2**
 Threaded version; Cap diameter Ø101 mm (Ø3.98 in) **3**

③ Pressurisation

Without pressurisation (standard option) **0**
 Pressurised at 0,2 bar / 3 PSI **B0.2**
 Pressurised at 0,35 bar / 5 PSI **B0.35**
 Pressurised at 0,7 bar / 10 PSI **B0.7**

Type SPB-1 is only available without pressurisation. Please see page 26 for details.

④ Air Filter Element (Material / Micron Rating)

10 µm Foam / PUR (standard option) **10**
 40 µm Foam / PUR **40**
 3 µm Inorganic Glass-Fibre, pleated **E03**
 10 µm Filter Paper, pleated **L10**

Options E03 and L10 are only available for type SPB-3. Contact STAUFF for alternative materials / micron ratings.

⑤ Connection Thread (Male)

G1/4 (for SPB-1 only) **B04**
 G3/8 (for SPB-1 and 2 only) **B06**
 G1/2 (for SPB-1, 2 and 3) **B08**
 G3/4 (for SPB-2 and 3 only) **B12**
 G1 (for SPB-3 only) **B16**
 1/4 NPT (for SPB-1 only) **N04**
 3/8 NPT (for SPB-1 only) **N06**
 1/2 NPT (for SPB-1 only) **N08**
 3/4 NPT (for SPB-1, 2 and 3) **N12**
 1 NPT (for SPB-3 only) **N16**

⑥ Anti-Splash Feature

With anti-splash feature (standard option) **A**
 Without anti-splash feature **0**

The anti-splash feature for the SPB-1, can only be achieved in conjunction with a dipstick, but is not available for the SPB-1 with connection sizes B04 and N04. Please see page 26 for details.

⑦ Dipstick

Plastic dipstick (200 mm / 7.88 in) with integrated anti-splash feature **D200**
 Plastic dipstick (300 mm / 11.81 in) with integrated anti-splash feature **D300**
 Plastic dipstick (300 mm / 11.81 in) with integrated magnet **D300M**
 Without dipstick **-**

A shorter dipstick length can be achieved by simply cutting down the total length according to individual requirements. Please see page 26 for details.



Plastic Filler Breather
Types SPB-4 / 5
(Flange Version)

B

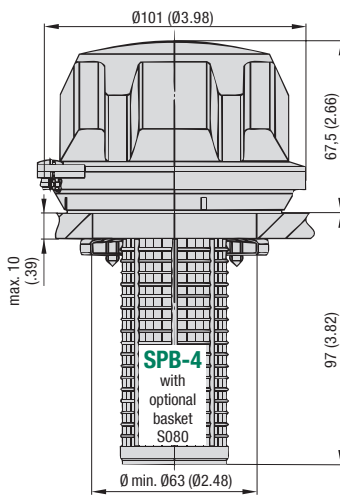

Clamping jaw installation
to a single mounting hole

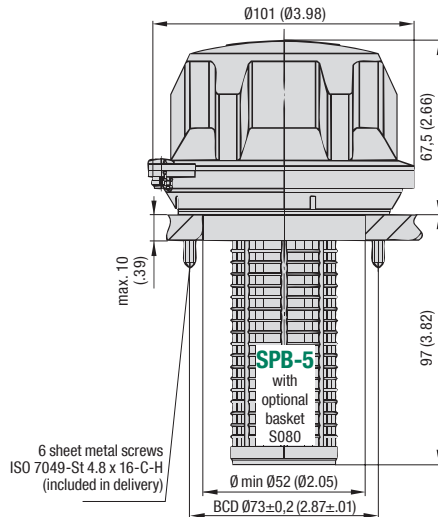

Installation to a six-hole bolt pattern
with flange interface similar to DIN 24557, Part 2



Characteristics

Designed to be used as filler ports for hydraulic reservoirs, allowing the reservoir to breathe whilst protecting it from contamination found in harsh environments

Features

- Cap diameter of Ø101 mm / Ø3.98 in
- Either for clamping installation (with 3 clamping jaws and cross-drive screws) or with a six-hole bolt pattern
- Operating temperature range: -40 °C ... +120 °C / -40 °F ... +248 °F

Materials

- Made of non-corrosive materials
- Body and cap made of glass-fibre reinforced Polyamide (PA)
- Sealings made of NBR (Buna-N®)

Contact STAUFF for alternative materials.

Accessories / Options

- Plastic basket (800 µm)
- Pressurisation up to 0,7 bar / 10 PSI
- Air filter element
- Anti-splash feature
- Plastic dipstick with integrated anti-splash feature
- Plastic dipstick with integrated magnet

Please see page 26 for details.

Maximum Air Flow Rate

- 1,00 m³/min / 35.31 cfm for SPB-4 / 5

Please see page 27 for detailed air flow curves.

Installation

- Recommended mounting space: Ø122 mm / Ø4.80 in
- Six-hole bolt pattern for flange interfaces similar to DIN 24557, part 2 (type SPB-5):

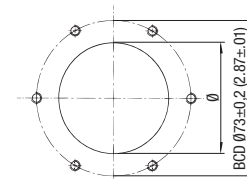

- 6 sheet metal screws (ISO 7049-St 4.8 x 16-C-H) are included in delivery (type SPB-5); can be replaced by regular M5 socket cap screws (ISO 4762), if required
- Recommended diameters of the screw holes, depending on the sheet thickness of the reservoir (type SPB-5): Ø4,0 mm / Ø.16 in at a thickness of 1,20 mm / .05 in, Ø4,1 mm / Ø.16 in at a thickness of 2,00 mm / .08 in, Ø4,3 mm / Ø.17 in at a thickness of 4,00 mm / .16 in, and Ø4,4 mm / Ø.17 in at a thickness of 5,00 mm / .20 in

Order Codes

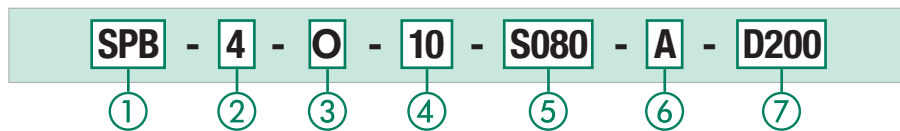

① Type

Plastic Filler Breather **SPB**

② Version

Bayonet version for clamping jaw installation to a single mounting hole; Cap diameter Ø101 mm (Ø3.98 in) **4**
 Bayonet Version with six-hole bolt pattern for flange interfaces similar to DIN 24557, part 2; Cap diameter Ø101 mm (Ø3.98 in) **5**

③ Pressurisation

Without pressurisation (standard option) **0**
 Pressurised at 0,2 bar / 3 PSI **B0.2**
 Pressurised at 0,35 bar / 5 PSI **B0.35**
 Pressurised at 0,7 bar / 10 PSI **B0.7**

Please see page 26 for details.

④ Air Filter Element (Material / Micron Rating)

10 µm Foam / PUR (standard option) **10**
 40 µm Foam / PUR **40**
 3 µm Inorganic Glass-Fibre, pleated **E03**
 10 µm Filter Paper, pleated **L10**

Contact STAUFF for alternative materials / micron ratings.

⑤ Basket Option

Plastic basket (105 mm / 4.13 in) **S080**
 Telescopic plastic basket **S200**
 Plastic basket with flange interface similar to DIN 24557, part 2 (95 mm / 3.74 in) **S095P**
 Without basket **X**

Option S095P is only available for type SPB-5. Please see page 26 for details.

⑥ Anti-Splash Feature

With anti-splash feature (standard option) **A**
 Without anti-splash feature **0**

⑦ Dipstick

Plastic dipstick (200 mm / 7.88 in) with integrated anti-splash feature **D200**
 Plastic dipstick (300 mm / 11.81 in) with integrated anti-splash feature **D300**
 Plastic dipstick (300 mm / 11.81 in) with integrated magnet **D300M**
 Without dipstick **-**

A shorter dipstick length can be achieved by simply cutting down the total length according to individual requirements. When choosing a combination of a basket and a dipstick, the dipstick has to be at least 15 mm / .59 in shorter than the basket. Please see page 26 for details.



Plastic Dipstick Types DS-1 / 2 / 3 Anti-Splash Feature

B

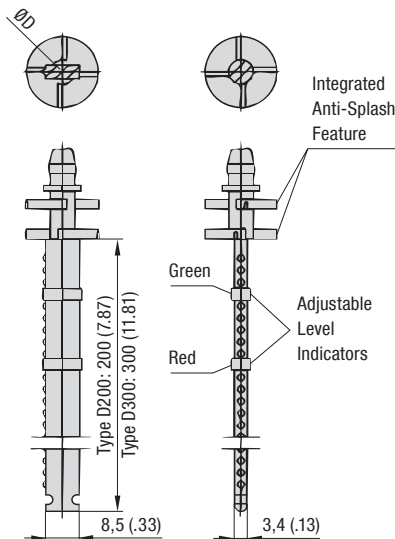
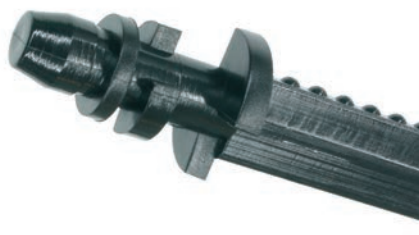

Connection	Code	For Type	Suitable Dipstick*	ØD (mm/in)	
Male BSP Thread (ISO 228)	G1/4	B04	SPB-1	Dipstick Option Not Available	
	G3/8	B06	SPB-1/2	DS-1	10 / .39
	G1/2	B08	SPB-1/2/3	DS-2	14 / .55
			SPBM		
	G3/4	B12	SPB-1/2	DS-3	18 / .71
			SMBT-80	DS-1	10 / .39
G1	B16	SPB-3	DS-3	18 / .71	
		SMBT-80	DS-1	10 / .39	
Male NPT Thread (ANSI B1.20.1)	1/4	N04	SPB-1	Dipstick Option Not Available	
	3/8	N06	SPB-1	DS-1	10 / .39
	1/2	N08	SPB-1	DS-2	14 / .55
			SPB-1/2/3	DS-3	18 / .71
	3/4	N12	SMBT-80	DS-1	10 / .39
			SPB-3	DS-3	18 / .71
1	N16	SMBT-80	DS-1	10 / .39	
Plastic Basket	S080	SPB-4/5	DS-3	18 / .71	
	S095-P	SPB-5	DS-3	18 / .71	
	S200	SPB-4/5	DS-3	18 / .71	
w/o Basket	X	SPB-4/5	DS-3	18 / .71	
		SMBB-80	DS-1	10 / .39	

* When ordered separately, please add the length of the dipstick (in mm) to the ordering code (e.g. DS-2-300).

For all Plastic Filler Breathers (except type SPB-1 with connection sizes B04 and N04), dipsticks made of Polyamide are available as an option. These dipsticks are available in 2 standard lengths of 200 mm / 7.87 in and 300 mm / 11.81 in and equipped with 2 adjustable level indicators in green and red colour.

All dipsticks have an integrated anti-splash feature protecting the SPB from backspilling fluid and avoiding an early breakdown of the air filter element.

Optionally a powerful magnet collects metal particles from the oil and gives extra safety for your application.

A shorter dipstick length can be achieved by simply cutting down the total length according to individual requirements. The markings at 25,4 mm / 1.00 in do assist simply cutting.

Please note: When choosing a combination of a dipstick and a basket (see below), the dipstick has to be at least 15 mm / .59 in shorter than the basket.

Special designs and alternative materials available on request. Please contact STAUFF for further details.

Plastic Basket ▪ Types S080 / S095-P / S200

For the Plastic Filler Breathers SPB-4 and SPB-5, different types of baskets are available as an option. All baskets have a reinforced 0,8 x 3,5 mm / .03 x .14 in mesh (800µm), so that rough dirt particles are filtered out of the medium and a smooth flow into the tank is being ensured.

The **Plastic Basket S080** (length of 105 mm / 4.13 in) snaps into the breather housing and suitable for the SPB-4 and SPB-5.

The **Plastic Basket S095-P** (length of 95 mm / 3.74 in) is equipped with a six-hole bolt pattern with flange interface similar to DIN 24557, part 2. It is suitable for the SPB-5 / SMBB-80 only and is installed between the breather housing and the reservoir.

The **Telescopic Plastic Basket S200** (maximum length of 205 mm / 8.07 in) is ideal to further improve the straining ability and oil flow-through and allowing longer dipstick lengths, where reservoir depth allows. It also snaps into the breather housing and is suitable for the SPB-4 and SPB-5.

Please note: When choosing a combination of a dipstick (see above) and a basket, the dipstick has to be at least 15 mm / .59 in shorter than the basket.

Special designs and alternative materials available on request. Please contact STAUFF for further details.

Plastic Basket S080 (for SPB-4/5)
Material: Polypropylene (PP)

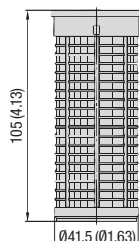

Plastic Basket S095-P (only for SPB-5 / SMBB-80)
Material: Polyamide (PA)

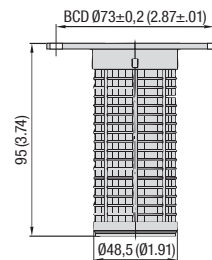

Six-hole bolt pattern with flange interface according to DIN 24557, part 2

Telescopic Plastic Basket S200 (for SPB-4/5)
Material: Polypropylene (PP)

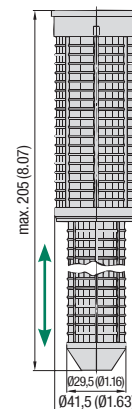

Pressurisation

Many tank filler breathers of the SPB, SMBB and SMBT series are also available as pressurised versions. Information on the specific valve and pressurization settings that are available by default can be found on the corresponding catalogue pages.

When the fluid level inside the reservoir rises, no air is expelled from the reservoir until the pressurisation level is reached. With decreasing fluid level inside the reservoir, the tank pressure drops and it is ensured that air is drawn into the reservoir.

Due to less breathing, the service life of a filler breather and the oil can be increased by using the pressurisation feature. It also minimizes foaming and cavitation, and provides additional protection from moisture entering the reservoir which causes erosion and oil degradation.

Further Accessories / Options



Weld Riser - Type WR
Suitable for SPB-5
(See page 39 for details)

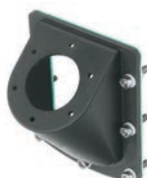

Side Mount Bracket (Polyamide) - Type ASMB-1
Suitable for SPB-5
(See page 38 for details)



Side Mount Bracket (Aluminium) - Type ASMB-2
Suitable for SPB-5
(See page 38 for details)

Dimensional drawings: All dimensions in mm (in).



Pressure Drop Flow Curves
Plastic Filler Breathers

B

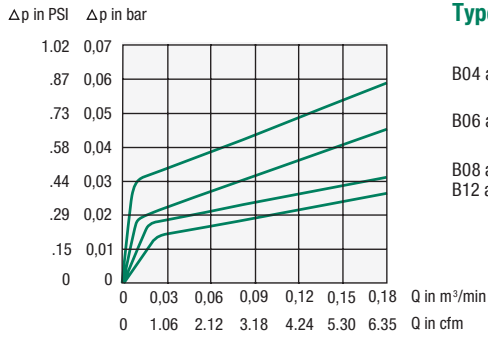

Type SPB-1 (into / out of the tank)

- B04 and N04 (into / out of the tank)
- B06 and N06 (into / out of the tank)
- B08 and N08 (into / out of the tank)
- B12 and N12 (into / out of the tank)

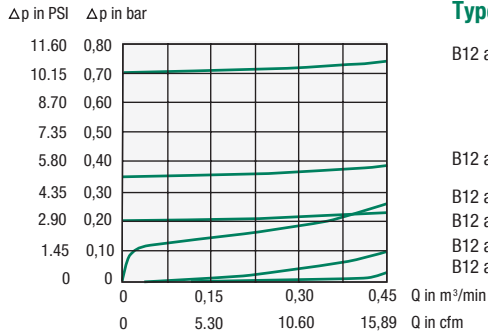

Type SPB-2 (into / out of the tank)

- B12 and N12 (out of the tank; pressurised at 0,7 bar / 10 PSI)
- B12 and N12 (out of the tank; pressurised at 0,35 bar / 5 PSI)
- B12 and N12 (into the tank; pressurised at 0,7 bar / 10 PSI, 0,35 bar / 5 PSI or 0,2 bar / 3 PSI)
- B12 and N12 (out of the tank; pressurised at 0,2 bar / 3 PSI)
- B12 and N12 (out of the tank; without pressurisation)
- B12 and N12 (into the tank; without pressurisation)

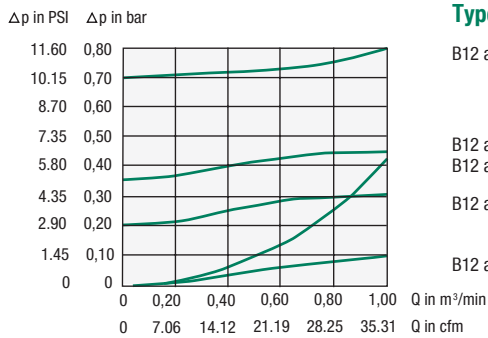

Type SPB-3 (into / out of the tank)

- B12 and N12 (out of the tank; pressurised at 0,7 bar / 10 PSI)
- B12 and N12 (out of the tank; pressurised at 0,35 bar / 5 PSI)
- B12 and N12 (into the tank; pressurised at 0,7 bar / 10 PSI, 0,35 bar / 5 PSI or 0,2 bar / 3 PSI)
- B12 and N12 (out of the tank; pressurised at 0,2 bar / 3 PSI)
- B12 and N12 (into / out of the tank; without pressurisation)

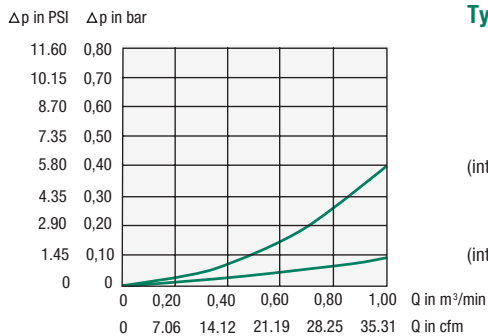

Type SPB-4/5 (into the tank)

- (into the tank; pressurised at 0,7 bar / 10 PSI, 0,35 bar / 5 PSI or 0,2 bar / 3 PSI)
- (into the tank; without pressurisation)

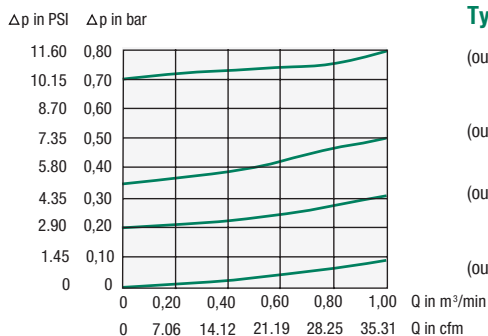

Type SPB-4/5 (out of the tank)

- (out of the tank; pressurised at 0,7 bar / 10 PSI)
- (out of the tank; pressurised at 0,35 bar / 5 PSI)
- (out of the tank; pressurised at 0,2 bar / 3 PSI)
- (out of the tank; without pressurisation)



Plastic Filler Breather Type SPBN (Compact Design; Threaded or Bayonet Version)

B



Height above tank
– 15 mm / –.59 in
in comparison with
SPB-2

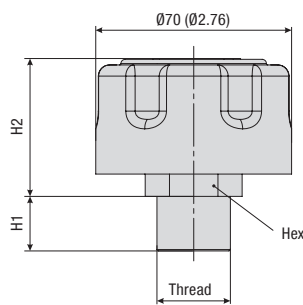

SPBN
Threaded Version

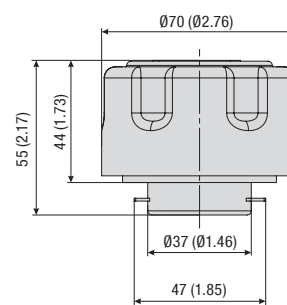

SPBN
Bayonet Version

Characteristics

Designed to be used as filler ports for hydraulic reservoirs, allowing the reservoir to breathe whilst protecting it from contamination found in harsh environments; ideal for applications in which space is limited

Features

- Cap diameter of 070 mm / 02.76 in
- Threaded version, equipped with male BSP thread (ISO 228) or male NPT thread (ANSI B1.20.1)
- Bayonet version for flange interfaces, with a six-hole bolt pattern, similar to DIN 24557, part 2
- Operating temperature range: -40 °C ... +120 °C / -40 °F ... +248 °F

Materials

- Body and cap made of glass-fibre reinforced Polyamide (PA)
- Socket made of Steel, zinc-plated
- Bayonet flange made of Steel, zinc-plated
- Basket made of Steel, zinc-plated or Polyamide (PA)
- Sealings made of NBR (Buna-N®)

Contact STAUFF for alternative materials.

Accessories / Options

- Mounting set including bayonet flange, steel or plastic basket (800 µm), gaskets and bolts
- Pressurisation up to 0,7 bar / 10 PSI
- Air filter element
- Anti-splash feature (for Threaded version only)
- Plastic dipstick with integrated anti-splash feature
- Plastic dipstick with integrated magnet
- Oil Demister

Please see pages 29 and 47 for details.

Maximum Air Flow Rate

- 0,40 m³/min / 14.13 cfm

Please see page 29 for detailed air flow curves.

Installation

- Six-hole bolt pattern for flange interfaces similar to DIN 24557, part 2 (bayonet version with mounting set):

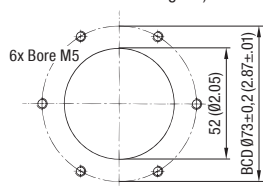

- 6 slotted pan head screws (ISO 1580 M5 x 12-5.8) are included in delivery of the bayonet version with mounting set

Dimensions (Threaded Version)

Thread	Dimensions (mm/in)		
	H1	H2	Hex
Male G3/4 BSP (ISO 228)	19,5 .77	49,5 1.95	30 1.18

Thread	Dimensions (mm/in)		
	H1	H2	Hex
Male 3/4 NPT (ANSI B1.20.1)	19,5 .77	49,5 1.95	30 1.18

Order Codes

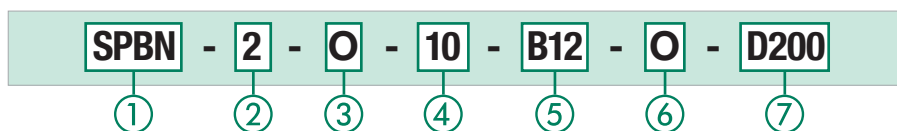

① Type

Plastic Filler Breather (Compact Design) **SPBN**

② Version

Cap diameter 070 mm (02.76 in) **2**

③ Pressurisation

Without pressurisation (standard option) **0**
 Pressurised at 0,2 bar / 3 PSI **B0.2**
 Pressurised at 0,35 bar / 5 PSI **B0.35**
 Pressurised at 0,7 bar / 10 PSI **B0.7**

Please see page 29 for details.

④ Air Filter Element (Material / Micron Rating)

10 µm Foam / PUR (standard option) **10**
 40 µm Foam / PUR **40**

Contact STAUFF for alternative materials / micron ratings.

⑤ Connection

Threaded version; Male G3/4 thread **B12**
 Threaded version; Male 3/4 NPT thread **N12**
 Bayonet version; Breather only **BS**
 Bayonet version; Breather including mounting set (with bayonet flange, gaskets and bolts) **BM**
 Bayonet version; Option BS and metal basket with flange interface (80 mm / 3.15 in) **S080**
 Bayonet version; Option BS and metal basket with flange interface (100 mm / 3.94 in) **S100**
 Bayonet version; Option BS and metal basket with flange interface (150 mm / 5.91 in) **S150**
 Bayonet version; Option BS and metal basket with flange interface (200 mm / 7.87 in) **S200**
 Bayonet version; Option BS and plastic basket with flange interface (95 mm / 3.74 in) **S095P**

⑥ Anti-Splash Feature

With anti-splash feature **A**
 Without anti-splash feature (standard option) **0**

Please see page 29 for details.

⑦ Dipstick

Plastic dipstick (200 mm / 7.88 in) with integrated anti-splash feature **D200**
 Plastic dipstick (300 mm / 11.81 in) with integrated anti-splash feature **D300**
 Plastic dipstick (300 mm / 11.81 in) with integrated magnet **D300M**
 Without dipstick **-**

A shorter dipstick length can be achieved by simply cutting down the total length according to individual requirements. Please see page 26 for details.

Dimensional drawings: All dimensions in mm (in).



Plastic Dipstick Anti-Splash Feature

For all Plastic Filler Breathers SPBN, dipsticks made of Polyamide are available as an option. These dipsticks are available in 2 standard lengths of 200 mm / 7.87 in and 300 mm / 11.81 in and equipped with 2 adjustable level indicators in green and red colour. A shorter dipstick length can be achieved by simply cutting down the total length according to individual requirements.

All dipsticks have an integrated anti-splash feature protecting the SPBN from backspilling fluid and avoiding an early breakdown of the air filter element. For Plastic Filler Breathers without dipstick, the anti-splash function can be achieved by an integrated concave baffle.

Please note: When choosing a combination of a dipstick and a basket, the dipstick has to be at least 15 mm / .59 in shorter than the basket.

Special designs and alternative materials available on request.
Please contact STAUFF for further details.

Pressurisation

Many tank filler breathers of the SPB, SMBB and SMBT series are also available as pressurised versions. Information on the specific valve and pressurization settings that are available by default can be found on the corresponding catalogue pages.

When the fluid level inside the reservoir rises, no air is expelled from the reservoir until the pressurisation level is reached. With decreasing fluid level inside the reservoir, the tank pressure drops and it is ensured that air is drawn into the reservoir.

Due to less breathing, the service life of a filler breather and the oil can be increased by using the pressurisation feature. It also minimizes foaming and cavitation, and provides additional protection from moisture entering the reservoir which causes erosion and oil degradation.

Mounting Set for Baskets (including Bayonet Flange, Gaskets and Bolts)

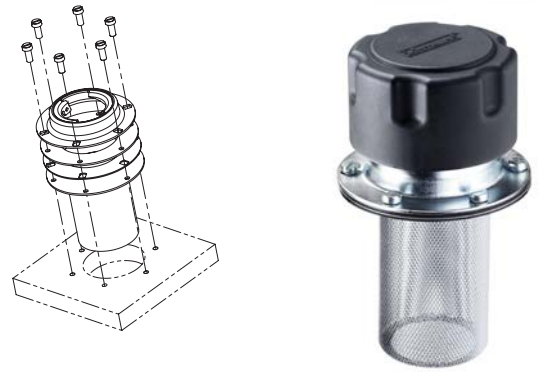

Scope of Delivery / Order Codes

Mounting sets for baskets include the following components:

- 6 slotted pan head screws made of steel, zinc-plated (ISO 1580 M5 x 12-5.8)
 - Bayonet flange made of steel, zinc-plated, with six-hole bolt pattern acc. to DIN 24557, part 2
 - 2 gaskets made of NBR (Buna-N®) - one for underneath and one for on top of the basket
 - Metal or plastic basket (only if required):
- | | |
|-----------------------------------|----------------------------|
| Metal basket (80 mm / 3.15 in): | S-080-M-F-SPBN-BS-B |
| Metal basket (100 mm / 3.94 in): | S-100-M-F-SPBN-BS-B |
| Metal basket (150 mm / 5.91 in): | S-150-M-F-SPBN-BS-B |
| Metal basket (200 mm / 7.87 in): | S-200-M-F-SPBN-BS-B |
| Plastic basket (95 mm / 3.74 in): | S-095-P-F-SPBN-BS-B |
| Without basket: | Adapter-SPBN-BM-B |

Mounting sets can also be ordered as part of a complete breather assembly.
Please see page 28 for details.

Further Accessories / Options



Extended Bayonet Flange - Type EBF
Suitable for SPBN; Bayonet Version BM
(See page 39 for details)



Weld Riser - Type WR
Suitable for SPBN; Bayonet Version BM
(See page 39 for details)

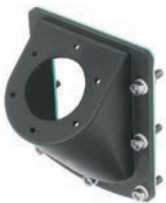

Side Mount Bracket (Polyamide) - Type ASMB-1
Suitable for SPBN; Bayonet Version BM
(See page 38 for details)



Side Mount Bracket (Aluminium) - Type ASMB-2
Suitable for SPBN; Bayonet Version BM
(See page 38 for details)

Pressure Drop Flow Curves Plastic Filler Breathers

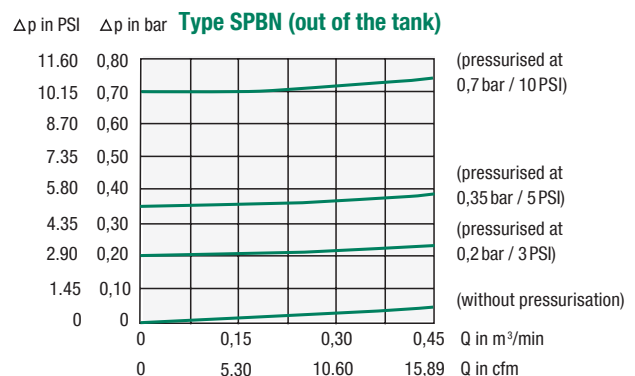
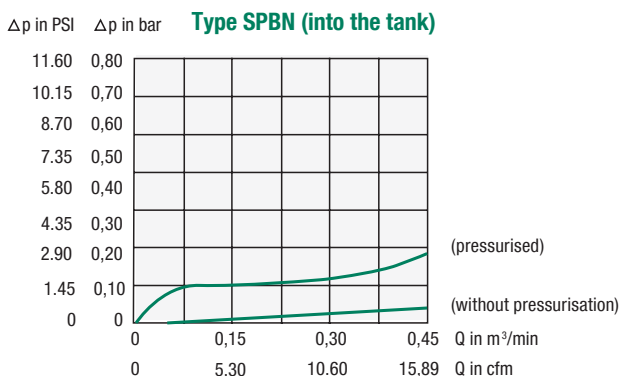

Plastic Filler Breather Mini Type SPBM (Threaded Version)

B

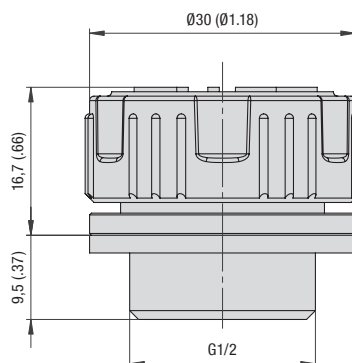

Characteristics

Designed to be used as filler ports for hydraulic reservoirs, allowing the reservoir to breathe whilst protecting it from contamination found in harsh environments

Features

- Available with different cap Logos
- Threaded version, equipped with male BSP thread (ISO 228)
- Operating temperature range: -40 °C ... +120 °C / -40 °F ... +248 °F

Materials

- Made of non-corrosive materials
- Body and cap made of glass-fibre reinforced Polyamide (PA)
- Sealings made of NBR (Buna-N®)

Contact STAUFF for alternative materials.

Accessories / Options

- Air filter element
- Anti-splash feature
- Plastic dipstick with integrated anti-splash feature
- Plastic dipstick with integrated magnet

Please see page 26 for details.

Maximum Air Flow Rate

- 0,25 m³/min / 8.83 cfm

Please see below for detailed air flow curves.

Installation

- Recommended mounting spaces: Ø48 mm / Ø1.89 in

Pressure Drop Flow Curves

Type SPBM (into the tank)

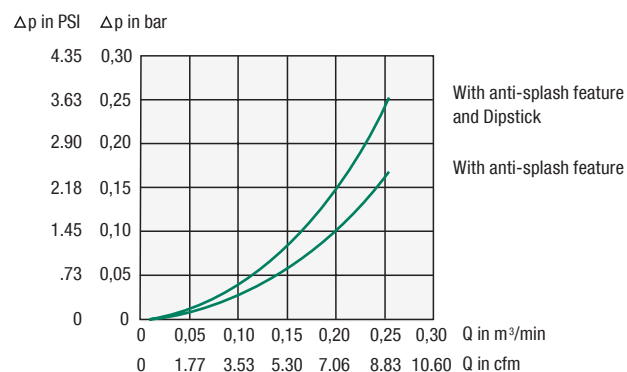

Type SPBM (out of the tank)

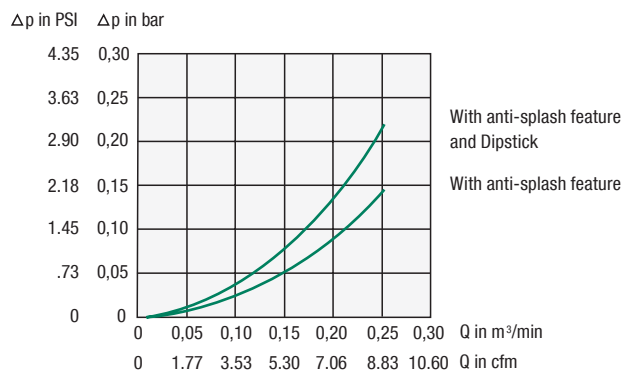

Dimensional drawings: All dimensions in mm (in).

Order Codes

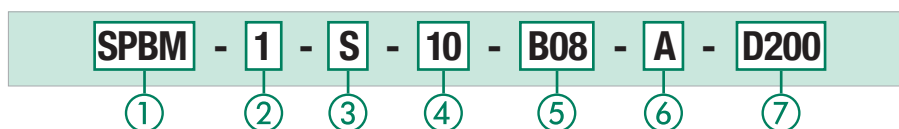

① Type

Plastic Filler Breather Mini **SPBM**

② Version

Threaded version; Cap diameter Ø30 mm (Ø1.18 in) **1**

③ Logo

STAUFF Logo (black cap) **S**
 OIL Logo (red cap) **O**
 Neutral design without any Logo **N**

Contact STAUFF for special Logos / Colors

④ Air Filter Element (Material / Micron Rating)

Without air filter element **0**
 10 µm Foam / PUR (standard option) **10**

Contact STAUFF for alternative materials / micron ratings.

⑤ Connection Thread (Male)

G1/2 BSP **B08**

⑥ Anti-Splash Feature

With anti-splash feature (standard option) **A**
 Without anti-splash feature **0**

⑦ Dipstick

Plastic dipstick (200 mm / 7.88 in) with integrated anti-splash feature **D200**
 Plastic dipstick (300 mm / 11.81 in) with integrated anti-splash feature **D300**
 Plastic dipstick (300 mm / 11.81 in) with integrated magnet **D300M**
 Without dipstick **-**

A shorter dipstick length can be achieved by simply cutting down the total length according to individual requirements. Please see page 26 for details.



Plastic Filler Breather Type SES (Threaded or Welded Versions)

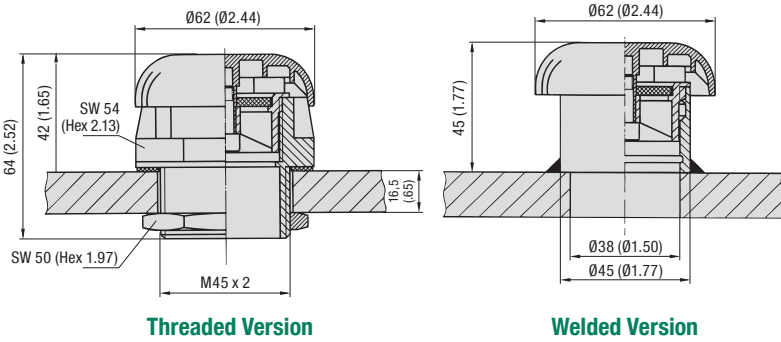

Order Codes

SES - 1 - M300

① ② ③

① Type

Plastic Filler Breather **SES**

② Version

Threaded version **1**
Welded version **2**

③ Basket / Dipstick Option

Plastic basket (81 mm / 3.19 in) **S**
Metal dipstick (300 mm / 11.81 in) **M300**
Metal dipstick (500 mm / 19.69 in) **M500**
Without basket / dipstick **0**

Accessories

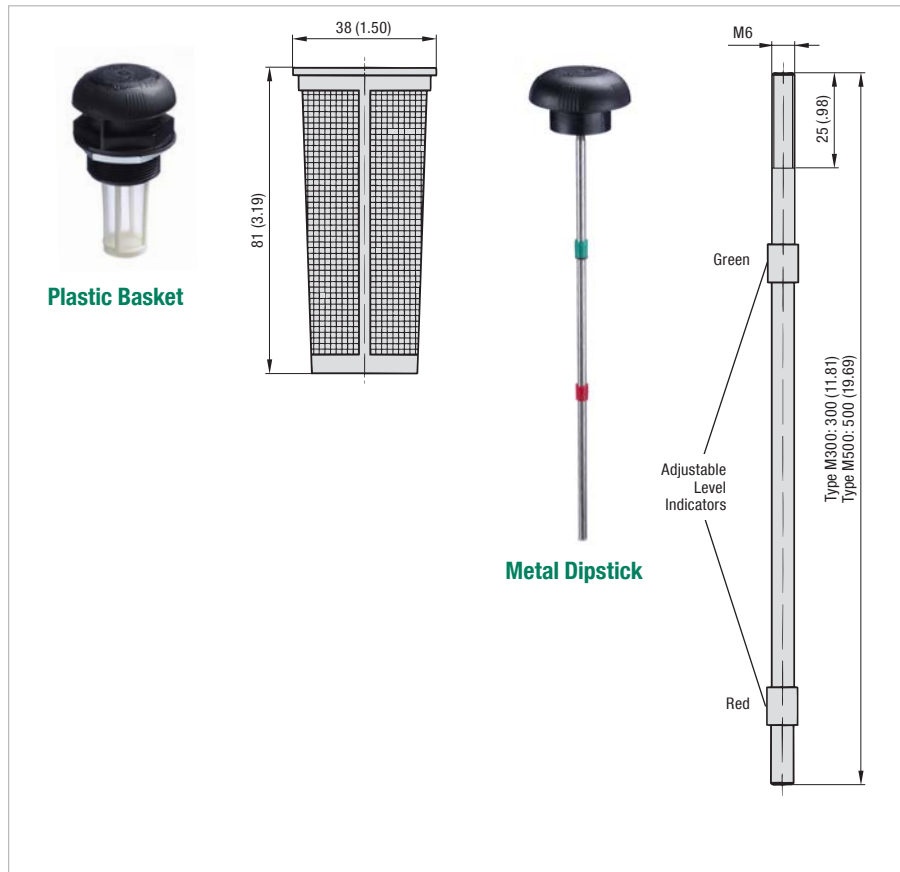

Characteristics

Designed to be used as filler ports for hydraulic reservoirs, allowing the reservoir to breathe whilst protecting it from contamination found in harsh environments

Features

- Cap diameter of 62 mm / 2.44 in
- Threaded version, equipped with male Metric ISO thread M45 x 2 and lock nut, or welded version with welding socket made of Steel (1.0718), untreated
- Supplied with 45 µm air filter element
- Operating temperature range: -40 °C ... +120 °C / -40 °F ... +248 °F

Materials

- Breather cap made of Polyamide (PA)
- Breather body / stud made of Polyamide (PA)
- Nut (type SES-1) made of Steel (1.0718); Polyamide (PA) available on request
- Welding socket (type SES-2) made of Steel (1.0718), untreated; Stainless Steel (V2A) available on request
- Air filter element made of Sintered Bronze
- Basket made of Polyamide (PA)
- Dipstick made of Steel (1.0718)
- Sealings made of NBR (Buna-N®)

Contact STAUFF for alternative materials.

Accessories / Options

- Plastic basket (300 µm)
- Metal dipstick

Maximum Air Flow Rate

- 0,30 m³/min / 10.60 cfm

Contact STAUFF for detailed air flow curves.



**Metal Filler Breather
Type SMBT-47
(Threaded Version)**

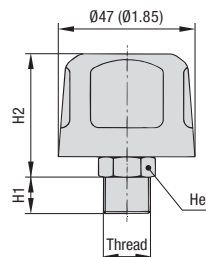

Characteristics

Designed to be used as filler ports for hydraulic reservoirs, allowing the reservoir to breathe whilst protecting it from contamination found in harsh environments

Features

- Cap diameter of Ø47 mm / Ø1.85 in
- Threaded version, equipped with male BSP thread (ISO 228) or male NPT thread (ANSI B1.20.1)
- Operating temperature range: -30 °C ... +120 °C / -22 °F ... +248 °F

Materials

- Breather cap made of Steel, zinc/nickel-plated (Fe/Zn Ni 6) and free of hexavalent chromium CrVI (standard option); chrome-plated and epoxy-coated versions available
- Threaded socket made of Steel, zinc-plated

Contact STAUFF for alternative materials.

Accessories / Options

- Air filter element

Maximum Air Flow Rate

- 0,40 m³/min / 14.13 cfm

Contact STAUFF for detailed air flow curves.

Dimensions

Thread	Dimensions (mm/in)		
	H1	H2	Hex
Male G1/4 BSP (ISO 228)	10 .39	41 2.38	17 .67
Male G3/8 BSP (ISO 228)	13 .51	41 2.38	19 .74
Male G1/2 BSP (ISO 228)	14 .55	41 2.38	22 .88

Thread	Dimensions (mm/in)		
	H1	H2	Hex
Male 1/4 NPT (ANSI B1.20.1)	13 .51	41 2.38	17 .67
Male 3/8 NPT (ANSI B1.20.1)	15 .59	41 2.38	19 .74

Contact STAUFF for alternative threads.

Order Codes

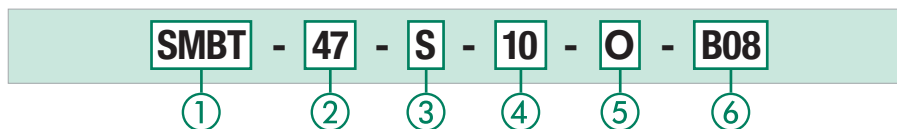

① Type / Version

Metal Filler Breather; Threaded version **SMBT**

② Cap Diameter / Material / Surface Finishing

Cap diameter Ø47 mm (Ø1.85 in); Breather cap made of Steel, zinc/nickel-plated (standard option)	47
Cap diameter Ø47 mm (Ø1.85 in); Breather cap made of Steel, chrome-plated	47C
Cap diameter Ø47 mm (Ø1.85 in); Breather cap made of Steel, epoxy-coated	47E

③ Label

With STAUFF logo (standard option)	S
Neutral design without any logo	N

④ Air Filter Element (Material / Micron Rating)

Without Breather Function	0
3 µm Filter Paper	03
10 µm Foam / PUR (standard option)	10
40 µm Foam / PUR	40

Contact STAUFF for alternative materials / micron ratings.

⑤ Pressurisation

Without pressurisation (standard option) **0**

No pressurisation available for this cap diameter.

⑥ Connection Thread (Male)

G1/4	B04
G3/8	B06
G1/2	B08
1/4 NPT	N04
3/8 NPT	N06

Contact STAUFF for alternative threads.



Metal Filler Breather Type SMBB-47 (Bayonet Version)

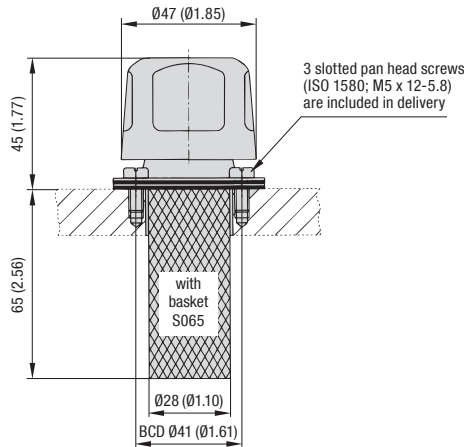

Characteristics

Designed to be used as filler ports for hydraulic reservoirs, allowing the reservoir to breathe whilst protecting it from contamination found in harsh environments

Features

- Cap diameter of Ø47 mm / Ø1.85 in
- Bayonet version with a three-hole bolt pattern
- Operating temperature range: -30 °C ... +120 °C / -22 °F ... +248 °F

Materials

- Breather cap made of Steel, zinc/nickel-plated (Fe/Zn Ni 6) and free of hexavalent chromium CrVI (standard option); chrome-plated and epoxy-coated versions available
- Bayonet flange made of Steel, zinc-plated
- Basket made of Steel, zinc-plated
- Sealings made of Cork

Contact STAUFF for alternative materials.

Accessories / Options

- Metal basket (800 µm)
- Air filter element

Maximum Air Flow Rate

- 0,40 m³/min / 14.13 cfm

Contact STAUFF for detailed air flow curves.

Installation

- Three-hole bolt pattern for flange interfaces:

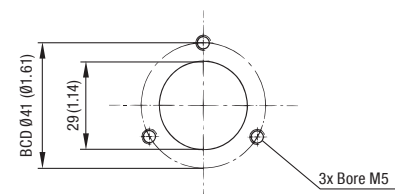

- 3 slotted pan head screws (ISO 1580 M5 x 12-5.8) are included in delivery; can be replaced by regular M5 bolts, if required

Order Codes

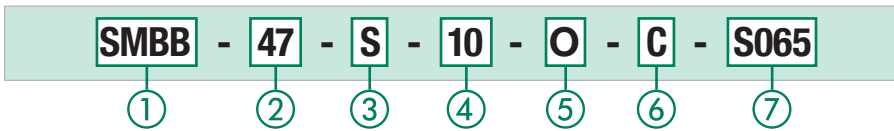

① Type / Version

Metal Filler Breather; Bayonet version **SMBB**

② Cap Diameter / Material / Surface Finishing

Cap diameter Ø47 mm (Ø1.85 in); Breather cap made of Steel, zinc/nickel-plated (standard option) **47**
 Cap diameter Ø47 mm (Ø1.85 in); Breather cap made of Steel, chrome-plated **47C**
 Cap diameter Ø47 mm (Ø1.85 in); Breather cap made of Steel, epoxy-coated **47E**

③ Label

With STAUFF logo (standard option) **S**
 Neutral design without any logo **N**

④ Air Filter Element (Material / Micron Rating)

Without Breather Function **0**
 3 µm Filter Paper **03**
 10 µm Foam / PUR (standard option) **10**
 40 µm Foam / PUR **40**

Contact STAUFF for alternative materials / micron ratings.

⑤ Pressurisation

Without pressurisation (standard option) **0**

No pressurisation available for this cap diameter.

⑥ Sealing Material

Cork (standard option) **C**

⑦ Basket Option

Metal basket (65 mm / 2.56 in) (standard option) **S065**
 Without basket **0**



**Metal Filler Breather
Type SMBT-80
(Threaded Version)**

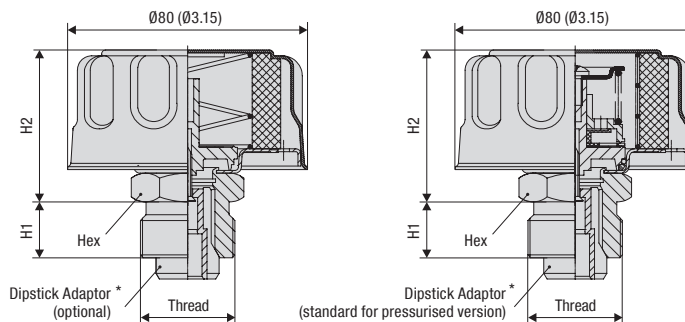

Without Pressurisation

Pressurised

* Please note: The dipstick adaptor is not available for connection threads G1/2 and 1/2 NPT.

Characteristics

Designed to be used as filler ports for hydraulic reservoirs, allowing the reservoir to breathe whilst protecting it from contamination found in harsh environments

Features

- Cap diameter of Ø80 mm / Ø3.15 in
- Threaded version, equipped with male BSP thread (ISO 228) or male NPT thread (ANSI B1.20.1)
- Operating temperature range: -30 °C ... +120 °C / -22 °F ... +248 °F

Materials

- Breather cap made of Steel, zinc/nickel-plated (Fe/Zn Ni 6) and free of hexavalent chromium CrVI (standard option); chrome-plated and epoxy-coated versions available
- Threaded socket made of Steel, zinc-plated
- Dipstick adaptor made of Polyamide (PA)

Contact STAUFF for alternative materials.

Accessories / Options

- Pressurisation up to 0,7 bar / 10 PSI
- Air filter element
- Dipstick adaptor suitable for plastic dipstick DS-1 (not for connection threads G1/2 and 1/2 NPT)
- Plastic dipstick DS-1 with integrated anti-splash feature (not for connection threads G1/2 and 1/2 NPT)
- Plastic dipstick with integrated magnet
- Oil Demister

Please see pages 26 and 47 for details.

Maximum Air Flow Rate

- 0,45 m³/min / 15.89 cfm

Contact STAUFF for detailed air flow curves.

Dimensions

Thread	Dimensions (mm/in)		
	H1	H2	Hex
Male G1/2 BSP (ISO 228)	14 .55	54 2.13	24 .94
Male G3/4 BSP (ISO 228)	16 .63	54 2.13	30 1.18
Male G1 BSP (ISO 228)	19 .75	54 2.13	36 1.42

Thread	Dimensions (mm/in)		
	H1	H2	Hex
Male 1/2 NPT (ANSI B1.20.1)	14 .51	52,5 2.07	24 .94
Male 3/4 NPT (ANSI B1.20.1)	16 .59	52,5 2.07	30 1.18
Male G1 NPT (ANSI B1.20.1)	19 .75	52,5 2.07	36 1.42

Order Codes

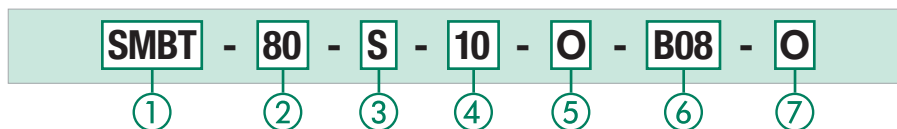

① Type / Version

Metal Filler Breather; Threaded version **SMBT**

② Cap Diameter / Material / Surface Finishing

Cap diameter Ø80 mm (Ø3.15 in); Breather cap made of Steel, zinc/nickel-plated (standard option) **80**
 Cap diameter Ø80 mm (Ø3.15 in); Breather cap made of Steel, chrome-plated **80C**
 Cap diameter Ø80 mm (Ø3.15 in); Breather cap made of Steel, epoxy-coated **80E**

③ Label

With STAUFF logo (standard option) **S**
 Neutral design without any logo **N**

④ Air Filter Element (Material / Micron Rating)

Without Breather Function **0**
 3 µm Filter Paper **03**
 10 µm Foam / PUR (standard option) **10**
 40 µm Foam / PUR **40**

Contact STAUFF for alternative materials / micron ratings.

⑤ Pressurisation

Without pressurisation (standard option) **0**
 Pressurised at 0,35 bar / 5 PSI **B0.35**
 Pressurised at 0,7 bar / 10 PSI **B0.7**

Please see page 26 for details.

⑥ Connection Thread (Male)

G1/2 **B08**
 G3/4 **B12**
 G1 **B16**
 1/2 NPT **N08**
 3/4 NPT **N12**
 1 NPT **N16**

Contact STAUFF for alternative threads.

⑦ Dipstick

Without dipstick (standard option) **0**
 With dipstick adaptor suitable for dipstick DS-1 (not for connection threads G1/2 and 1/2 NPT) **A**
 With dipstick adaptor and plastic dipstick DS-1 (300 mm / 11.81 in) with integrated anti-splash feature (not for connection threads G1/2 and 1/2 NPT) **D300**
 Plastic dipstick (300 mm / 11.81 in) with integrated magnet **D300M**

A shorter dipstick length can be achieved by simply cutting down the total length according to individual requirements.

Please note: The dipstick adaptor is required for the subsequent installation of plastic dipsticks DS-1 (see page 26 for details), and is included in delivery when ordering a pressurised version. The dipstick adaptor is not available for connection threads G1/2 and 1/2 NPT.

Dimensional drawings: All dimensions in mm (in).



Metal Filler Breather Type SMBB-80 (Bayonet Version)

B

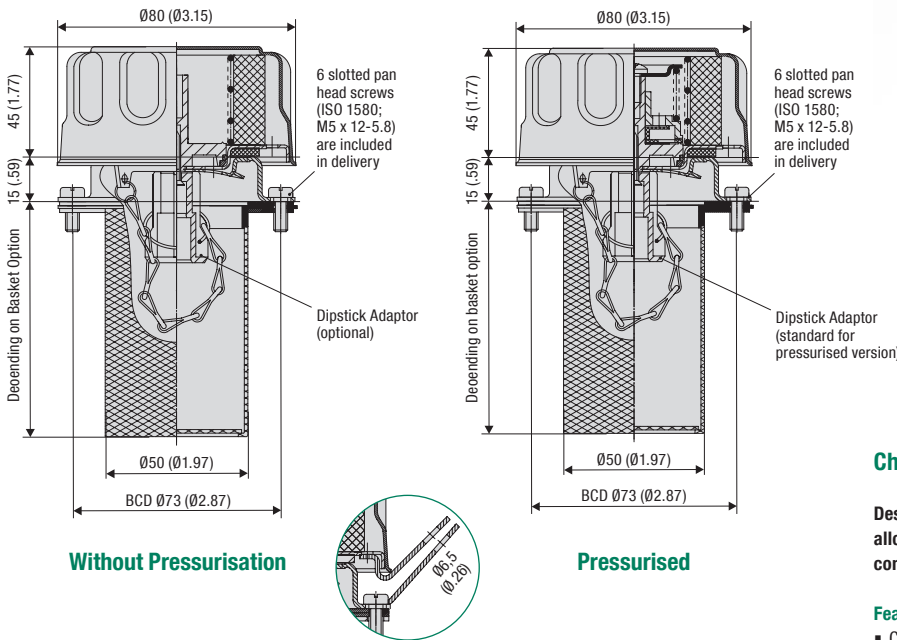

Characteristics

Designed to be used as filler ports for hydraulic reservoirs, allowing the reservoir to breathe whilst protecting it from contamination found in harsh environments

Features

- Cap diameter of Ø80 mm / Ø3.15 in
- Bayonet version with a six-hole bolt pattern for flange interfaces similar to DIN 24557, part 2
- Operating temperature range: -30 °C ... +120 °C / -22 °F ... +248 °F

Materials

- Breather cap made of Steel, zinc/nickel-plated (Fe/Zn Ni 6) and free of hexavalent chromium CrVI (standard option); chrome-plated and epoxy-coated versions available
- Bayonet flange made of Steel, zinc-plated
- Basket made of Steel, zinc-plated or Polyamide (PA)
- Dipstick adaptor made of Polyamide (PA)
- Sealings made of Cork (for filler breathers without pressurisation) or NBR (Buna-N®) (for pressurised filler breathers)

Contact STAUFF for alternative materials.

Accessories / Options

- Metal or plastic basket (800 µm)
- Pressurisation up to 0,7 bar / 10 PSI
- Air filter element
- Locking feature
- Dipstick adaptor (suitable for plastic dipstick DS-1)
- Plastic dipstick with integrated anti-splash feature
- Plastic dipstick with integrated magnet

Please see page 26 for details.

Maximum Air Flow Rate

- 0,45 m³/min / 15.89 cfm

Contact STAUFF for detailed air flow curves.

Installation

- Six-hole bolt pattern for flange interfaces similar to DIN 24557, part 2:

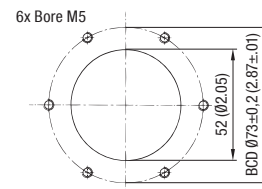

- 6 slotted pan head screws (ISO 1580 M5 x 12-5.8) are included in delivery; can be replaced by regular M5 bolts, if required

Locking Feature
(Recommended mounting space: Ø126 mm / Ø4.96 in)

Order Codes

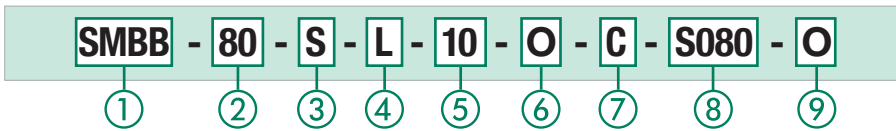

1 Type / Version

Metal Filler Breather; Bayonet version **SMBB**

2 Cap Diameter / Material / Surface Finishing

Cap diameter Ø80 mm (Ø3.15 in); Breather cap made of Steel, zinc/nickel-plated (standard option) **80**
 Cap diameter Ø80 mm (Ø3.15 in); Breather cap made of Steel, chrome-plated **80C**
 Cap diameter Ø80 mm (Ø3.15 in); Breather cap made of Steel, epoxy-coated **80E**

3 Label

With STAUFF logo (standard option) **S**
 Neutral design without any logo **N**

4 Locking Feature

Without locking feature (standard option) **O**
 With locking feature (see drawing above) **L**

5 Air Filter Element (Material / Micron Rating)

Without Breather Function **0**
 3 µm Filter Paper **03**
 10 µm Foam / PUR (standard option) **10**
 40 µm Foam / PUR **40**

Contact STAUFF for alternative materials / micron ratings.

6 Pressurisation

Without pressurisation (standard option) **0**
 Pressurised at 0,35 bar / 5 PSI **B0.35**
 Pressurised at 0,7 bar / 10 PSI **B0.7**

Please see page 26 for details.

7 Sealing Material

Cork (for filler breathers without pressurisation) **C**
 NBR (Buna-N®) (for pressurised filler breathers) **B**

8 Basket Option

Without basket **0**
 Metal basket (80 mm / 3.15 in) (standard option) **S080**
 Plastic basket (95 mm / 3.74 in) **S095P**
 Metal basket (100 mm / 3.94 in) **S100**
 Metal basket (150 mm / 5.91 in) **S150**
 Metal basket (200 mm / 7.87 in) **S200**

9 Dipstick

Without dipstick (standard option) **0**
 Dipstick adaptor (suitable for dipstick DS-1) **A**
 With dipstick adaptor and plastic dipstick DS-1 (300 mm / 11.81 in) with integrated anti-splash feature **D300**
 Plastic dipstick (300 mm / 11.81 in) with integrated magnet **D300M**

A shorter dipstick length can be achieved by simply cutting down the total length according to individual requirements.

Please note: The dipstick adaptor is required for the subsequent installation of plastic dipsticks DS-1 (see page 26 for details), and is content of delivery when ordering a pressurised version.



**Metal Breather
Type SMBP-80
(Push-On Version)**

B

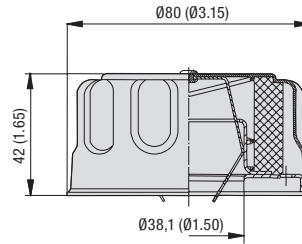

Characteristics

Designed to be used as filler ports for hydraulic reservoirs, allowing the reservoir to breathe whilst protecting it from contamination found in harsh environments

Features

- Cap diameter of 80 mm / 3.15 in
- Push-on version, suitable for pipe diameters up to 38 mm/ 1.50 in
- Operating temperature range: -30 °C ... +120 °C / -22 °F ... +248 °F

Materials

- Breather cap made of Steel, zinc/nickel-plated (Fe/Zn Ni 6) and free of hexavalent chromium CrVI (standard option); chrome-plated and epoxy-coated versions available

Contact STAUFF for alternative materials.

Accessories / Options

- Air filter element

Maximum Air Flow Rate

- 0,45 m³/min / 15.89 cfm

Contact STAUFF for detailed air flow curves.

Order Codes

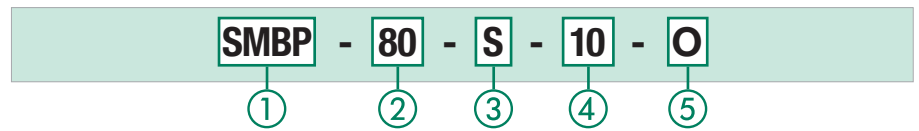

① **Type / Version**

Metal Breather; Push-on version **SMBP**

② **Cap Diameter / Material / Surface Finishing**

Cap diameter 80 mm (3.15 in); Breather cap made of Steel, zinc/nickel-plated (standard option) **80**
 Cap diameter 80 (3.15 in); Breather cap made of Steel, chrome-plated **80C**
 Cap diameter 80 (3.15 in); Breather cap made of Steel, epoxy-coated **80E**

③ **Label**

With STAUFF logo (standard option) **S**
 Neutral design without any logo **N**

④ **Air Filter Element (Material / Micron Rating)**

Without Breather Function **0**
 10 µm Foam / PUR (standard option) **10**
 40 µm Foam / PUR **40**

Contact STAUFF for alternative materials / micron ratings.

⑤ **Dipstick**

Without dipstick (standard option) **0**

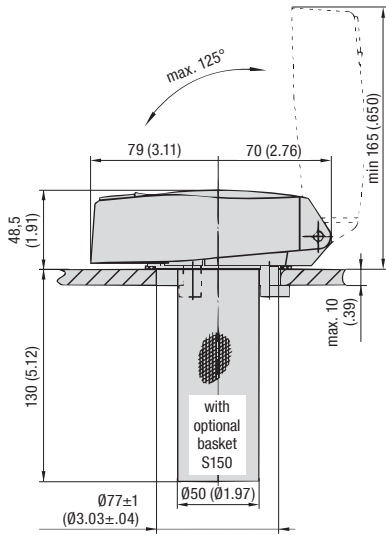
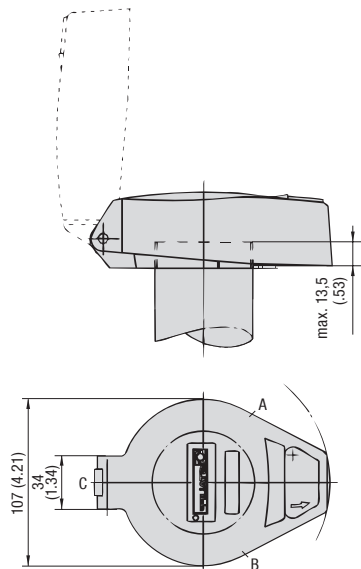

Clamping Version

Threaded Version

Recommended mounting space: Ø162 mm / Ø6.38 in
2 locking screws M6 x 6 (DIN 916) at positions A and B

Push-On Version

3 locking screws M6 x 6 (DIN 916) at positions A, B and C

Lockable Metal Filler Breather Type SMBL (Clamping, Threaded and Push-On Version)



Clamping version
with metal basket
(150 mm / 5.91 in)

Characteristics

Designed to be used as lockable filler ports for hydraulic reservoirs, allowing the reservoir to breathe whilst protecting it from contamination found in harsh environments

Features

- Available as clamping version (with 3 clamping jaws), as threaded version (with female BSP thread) or push-on version, suitable for stand pipe mounting with pipe diameters up to 77,5 mm / 3.05 in (secured by 3 locking screws)
- Key-lockable cap (2 keys included)
- Lock protected by rotating flap
- Operating temperature range:
-30 °C ... +100 °C / -22 °F ... +212 °F
- Air flow in both directions, one direction only or no direction

Materials

- Breather cap made of Aluminium, lacquered (light-grey, RAL 9022)
- Breather body made of Aluminium and steel zinc-plated
- Basket made of Steel, zinc-plated or Polypropylene (PP)
- Sealings made of NBR (Buna-N®) (standard option); FKM/FPM (Viton®) sealed version available

Contact STAUFF for alternative materials.

Accessories / Options

- Metal or plastic basket (800 µm; telescopic)
- Air filter element

Order Codes

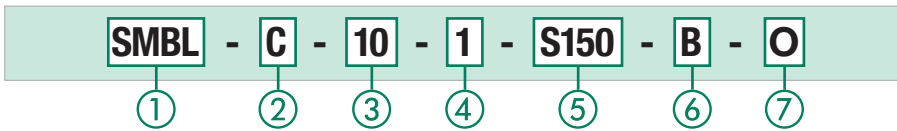

① Type

Lockable Metal Filler Breather **SMBL**

② Version

Clamping version with 3 clamping jaws; Installation to a tank mounting hole of Ø77±1 mm / Ø3.03±.04 in **C**
Threaded version with female G2 BSP thread **G32**
Threaded version with female G2-1/2 BSP thread **G40**
Push-on version for stand pipe mounting **P**

③ Air Filter Element (Material / Micron Rating)

Without Breather Function **0**
10 µm Foam / PUR (standard option) **10**
40 µm Foam / PUR **40**

Contact STAUFF for alternative materials / micron ratings.

④ Air Flow

Air flow in both directions (standard option) **1**
No air flow **2**
Air flow only into the tank **3**

⑤ Basket Option

Without basket **0**
Metal basket (150 mm / 5.91 in) (standard option) **S150**
Plastic basket (80 mm / 3.15 in) **S080**
Telescopic plastic basket (max. 205 mm / max. 8.07 in) **S200**

The baskets of the SMBB-47/80 series cannot be used in conjunction with the SMBL series.

⑥ Sealing Material

NBR (Buna-N®) (standard option) **B**
FKM/FPM (Viton®) **V**

⑦ Cap Design

Breather cap made of Aluminium, lacquered (light-grey, RAL 9022) **0**



Side Mount Bracket Type ASMB-1 (Polyamide Version)

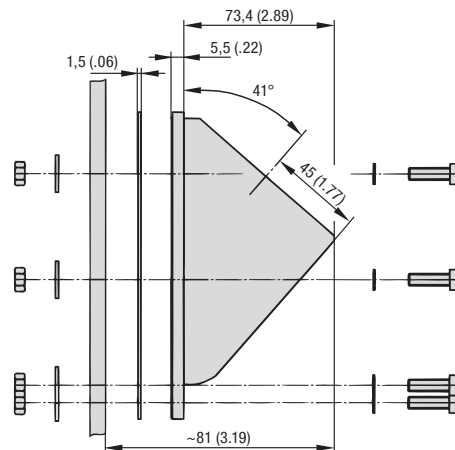
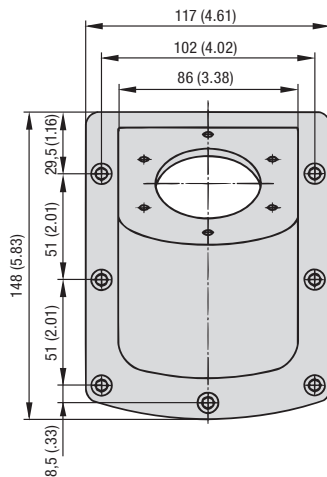

Characteristics

Lateral fastening of filler breathers with a six-hole flange connection similar to DIN 24557, part 2 to vertical or sloped walls of hydraulic reservoirs; ideal for applications in which space is limited

Suitability

- Suitable for Plastic Filler Breathers SPB-5 and SPBN (bayonet version) and Metal Filler Breathers SMBB-80

Materials

- Mounting bracket made of Polyamide (PA)
- Seal plate made of Klingerit
- Screws and hex nuts made of Steel, zinc-plated
- Washers made of Steel, zinc-plated
- Plastic spacers made of Polyamide (PA)

Scope of Delivery

- 1 mounting bracket
- 1 seal plate
- 7 socket cap screws M6 x 25 (ISO 4762)
- 7 plastic spacers 6,4 (DIN 125)
- 7 hex nuts M6 (ISO 4032)
- 7 washers 6,4 (DIN 9021)
- 6 sheet metal screws 4,8x13 (ISO 7049)

Installation

- Bolted to the side of the reservoir
- Bayonet flange of filler breather is placed on top
- Flange interface similar to DIN 24557, part 2 with 6 equally spaced mounting bores $\varnothing 4,5$ mm / $\varnothing 0.18$ in (BCD $\varnothing 71 \pm 0,2$ mm / $\varnothing 2.80 \pm 0.01$ in)

Order Codes

SMBB-ASMB - 1

① ②

① Type

Side Mount Bracket **SMBB-ASMB**

② Housing Material

Polyamide (PA) **1**

Side Mount Bracket Type ASMB-2 (Aluminium Version)

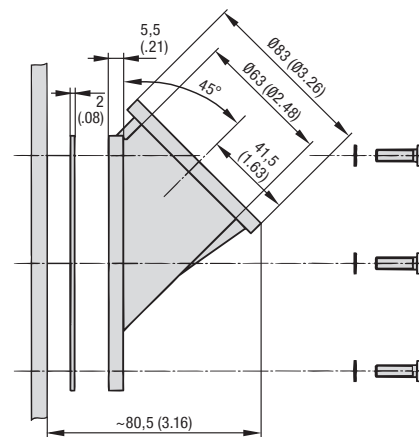
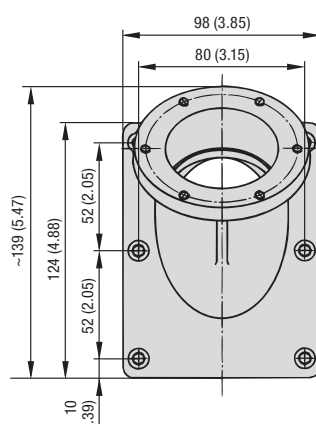

Characteristics

Lateral fastening of filler breathers with a six-hole flange connection similar to DIN 24557, part 2 to vertical or sloped walls of hydraulic reservoirs; ideal for applications in which space is limited

Suitability

- Suitable for Plastic Filler Breathers SPB-5 and SPBN (bayonet version) and Metal Filler Breathers SMBB-80

Materials

- Mounting bracket made of Aluminium
- Seal plate made of NBR (Buna-N®)
- Screws made of Steel, phosphated
- Washers made of gasket paper

Scope of Delivery

- 1 mounting bracket
- 1 seal plate
- 6 socket cap screws M6 x 20 (ISO 4762)
- 6 plastic spacers 6,4 (DIN 125)

Installation

- Bolted to the side of the reservoir
- Bayonet flange of filler breather is placed on top
- Flange interface similar to DIN 24557, part 2 with 6 equally spaced bores M5 (BCD $\varnothing 73 \pm 0,2$ mm / $\varnothing 2.87 \pm 0.01$ in)

Order Codes

SMBB-ASMB - 2

① ②

① Type

Side Mount Bracket **SMBB-ASMB**

② Housing Material

Aluminium **2**

Dimensional drawings: All dimensions in mm (in).



Extended Bayonet Flange Type EBF

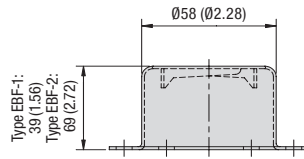
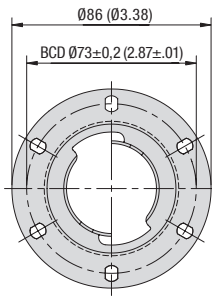

Order Codes

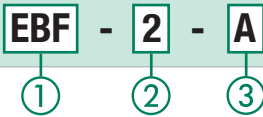

① Type	Extended Bayonet Flange	EBF
② Size	Total height of 39 mm (1.56 in)	1
	Total height of 69 mm (2.72 in)	2
③ Anti-Splash Feature	Without anti-splash feature (standard option)	-
	With anti-splash feature	A

Installation

- Six-hole bolt pattern for flange interfaces similar to DIN 24557, part 2:

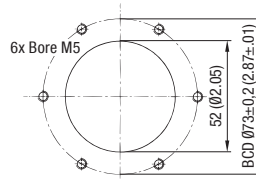

- Supplied without gaskets and bolts

Characteristics

Designed to raise filler breathers either 24 mm / .94 in or 54 mm / 2.12 in above the actual mounting surface of the reservoir to prevent contamination from blocking the filter element

Suitability

- Suitable for Metal Filler Breathers SMBB-80 and Plastic Filler Breathers SPBN (bayonet version)
- Replaces the existing bayonet flanges of these breathers

Materials

- Bayonet flange made of Steel, zinc-plated

Weld Riser Type WR

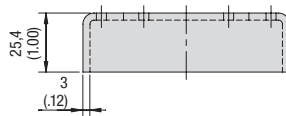
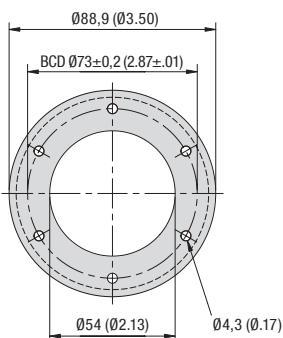

Order Codes



① Type	Weld Riser	WR
② Size	Total height of 25,4 mm (1.00 in)	1

Materials

- Weld riser made of Steel, untreated

Installation

- Welded to the top of the reservoir
- No requirement to drill and tap on the reservoir
- Bayonet flange of filler breather is placed on top

Characteristics

Designed to raise filler breathers 25,4 mm / 1.00 in above the actual mounting surface of the reservoir to prevent contamination from blocking the filter element whilst eliminating the requirement to drill and tap on the reservoir

Suitability









- Suitable for Metal Filler Breathers SMBB-80 as well as Plastic Filler Breathers SPB-5 and SPBN (bayonet version) and all components with a six-hole flange connection similar to DIN 24557, part 2



STAUFF®

Kommissionier-Shuttler
WALTER II



	Giant Air Breathers	42 - 43
	Giant Air Breather SGB	42
	Air Breather Adaptor TBA	43
	Desiccant Air Breathers	44 - 47
	SDB	44
	SVDB (Disposable Version)	45
	SDB-CV (with Check Valves)	46
	Adaptor Plate AP	47
	Visual Contamination Indicator FM	47
	Oil Demister TBA-OD	47

C



Giant Air Breather Type SGB

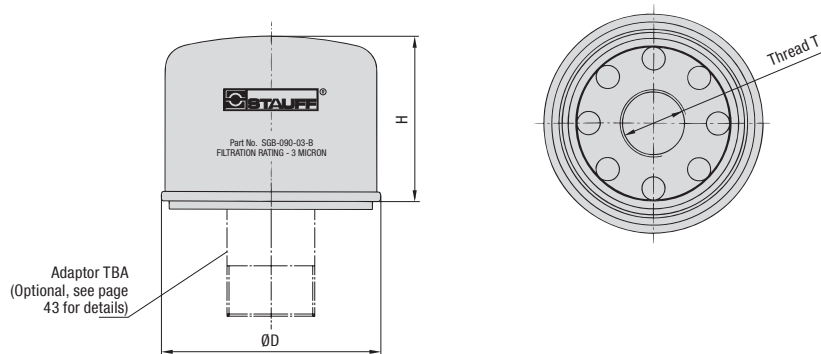

Characteristics

Originally designed to be used as replaceable air filter elements for STAUFF Desiccant Breathers, they can also be used as separate air filters for hydraulic reservoirs

Features

- Diameter of Ø68 mm / Ø2.68 in (SGB-060), Ø100 mm / Ø3.94 in (SGB-090) or Ø130 mm / Ø5.12 in (SGB-120)
- Equipped with female BSP thread (ISO 228)
- Including sealing made of NBR (Buna-N®)
- Operating temperature range: -32 °C ... +100 °C / -25 °F ... +212 °F

Accessories / Options

- Adaptors (for direct installation on top of hydraulic reservoirs)

Please see page 43 for a selection of adaptors available, and contact STAUFF for further information.

Air Flow

- Maximum air flow rates:
0,05 m³/min / 1.77 cfm for SGB-060,
0,70 m³/min / 24.71 cfm for SGB-090, and
1,50 m³/min / 52.97 cfm for SGB-120

Dimensions and Filter Specifications

Type	Thread T*	Dimensions (mm/in)		Filter Material	Micron Rating	Filter Surface	Max. Air Flow Rate
		ØD	H				
SGB-060-03-B	Female M20 x 1,5 (ISO 13-2)	68	60	Synthetic Fibre	3 µm	415 cm ²	0,05 m ³ /min
		2.68	2.36			63 in ²	1.77 cfm
SGB-090-03-B	Female G3/4 BSP (ISO 228)	100	64	Synthetic Fibre	3 µm	752 cm ²	0,70 m ³ /min
		3.94	2.52			115 in ²	24.71 cfm
SGB-120-03-B	Female G1-1/4 BSP (ISO 228)	130	100	Synthetic Fibre	3 µm	2095 cm ²	1,50 m ³ /min
		5.12	3.94			320 in ²	52.97 cfm

* Use adaptors TBA to change female BSP thread into male BSP or male NPT thread. Please see page 43 for details.

Order Codes

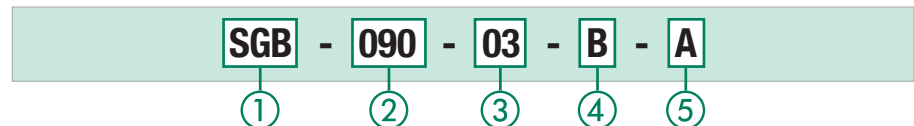

① Type

Giant Air Breather **SGB**

② Size

Diameter of Ø68 mm (Ø2.68 in) **060**
 Diameter of Ø100 mm (Ø3.94 in) **090**
 Diameter of Ø130 mm (Ø5.12 in) **120**

③ Filter Material / Micron Rating

3 µm Synthetic Fibre **03**

Contact STAUFF for alternative materials / micron ratings.

④ Connection Thread

Female BSP thread (according to dimension table) **B**

⑤ Adaptor Option

Without adaptor **-**
 With adaptor TBA-075-B (for SGB-090-03-B) or TBA-125-B (for SGB-120-03-B) **A**

If required, Giant Air Breathers SGB can also be supplied in combination with a wide range of further adaptors. Please see page 43 for a selection of adaptors available, and contact STAUFF for further information.



Breather Adaptor
Type TBA

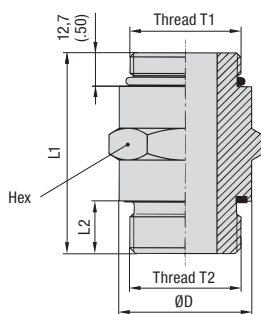

TBA-038-B
TBA-075-B
TBA-125-B

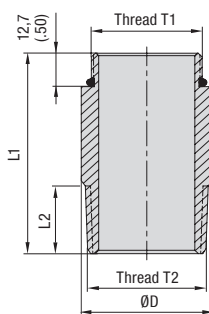

TBA-075
TBA-120
TBA-125



Order Codes and Dimensions

Thread T1	Thread T2	Dimensions (mm/in)				For Use with ...*	Order Code
		L1	L2	ØD	Hex		
Male G3/8 BSP (ISO 228)	Male G3/8 BSP (ISO 228)	43	11	21,9	22	Desiccant Air Breathers SDB-061-CV	TBA-038-B
		1.69	.43	.86	.86		
Male 1-12 UNF (ANSI B1.1)	Male 3/4 NPT (ANSI B1.20.1)	51	20	27	32	Spin-On Series SF-65	TBA-075
		2.00	.79	1.05			
Male G3/4 BSP (ISO 228)	Male G3/4 BSP (ISO 228)	57	16	32	32	Giant Air Breathers SGB-090 Desiccant Air Breathers SVDB-093 Desiccant Air Breathers SVDB-096 Spin-On Series SF-35 Spin-On Series SF-36	TBA-075-B
		2.24	.63	1.26			
Male G1-1/4 BSP (ISO 228)	Male 1-1/4 NPT (ANSI B1.20.1)	76	22	42	32	Giant Air Breathers SGB-120 Spin-On Series SF-57 Spin-On Series SF-58	TBA-120
		3.00	.88	1.65			
Male 1-1/2-16 UN (ANSI B1.1)	Male 1-1/4 NPT (ANSI B1.20.1)	76	26	45	32	Spin-On Series SF-67	TBA-125
		3.00	1.01	1.77			
Male G1-1/4 BSP (ISO 228)	Male G1-1/4 BSP (ISO 228)	76	20	50	50	Giant Air Breathers SGB-120 Spin-On Series SF-57 Spin-On Series SF-58	TBA-125-B
		3.00	.79	1.97			

* Please see Filtration Technology Catalogue for technical details on Spin-On filter elements.

Characteristics

Adopts from female threaded Giant Air Breather or Spin-On Filter Element to a male thread, and thus allows for direct installation on top of hydraulic reservoirs

Features

- Several thread combinations available to suit most common Spin-On filter elements
- Versions with male BSP threads on both ends are equipped with hex to simplify installation
- Sealings included in delivery

Materials

- Adaptor made of Steel, zinc-plated
- Sealings made of NBR (Buna-N®)

Contact STAUFF for alternative materials.

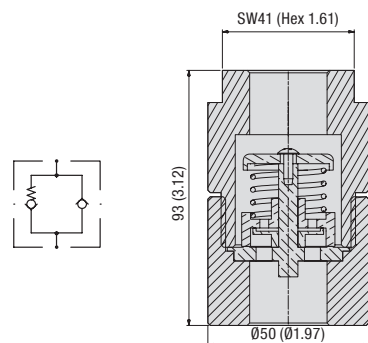

Characteristics

Increasing the service life and reducing maintenance intervals of tank filler breathers and desiccant breathers due to less breathing

Features

- Connections: Female G3/4 BSP threads (ISO 228)
- Pressurisation of 0,35 bar / 5 PSI (no air is expelled from the reservoir until the pressurisation level is reached)
- Suitable for use with various types of Desiccant Air Breathers including SDB-096/2, SDB-093/2, SVDB-096, SVDB-093 and SDB-096-CV as well as Tank Filler Breathers including SPB-2, SPB-3 and SMBT-80

Materials

- Housing made of Aluminium

Pressurised Breather Adaptor
Type TBA-075-P2



Dimensional drawings: All dimensions in mm (in).



Desiccant Air Breather Type SDB

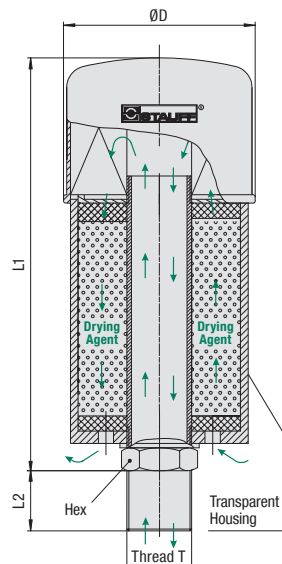

Drying Agent
Capable in changing colours with increasing moisture



This product does not contain any dangerous substances according to EC Council directives 99/45/EC and 2001/60/EC.

Dimensions and Technical Data

Type	Thread T	Dimensions (mm/in)				Weight (g/lbs)		Volume (cm ³ / in ³)	Max. Water Absorption (g/lbs)	Air Filter Elements	Filter Material	Micron Rating	Filter Surface	Max. Air Flow Rate
		ØD	L1	L2	Hex	Complete Unit	Drying Agent							
SDB-093/2	Male G3/4 BSP (ISO 228)	100	160	20	32	1200	225	300	86	SGB-090-03-B	Synthetic Fibre	3µm	752 cm ²	0,70 m ³ /min
		3.94	6.30	.79	1.26	2.65	.50	18.3	.19				115 in ²	24.71 cfm
SDB-096/2	Male G3/4 BSP (ISO 228)	100	220	20	32	1500	450	600	172	SGB-090-03-B	Synthetic Fibre	3µm	752 cm ²	0,70 m ³ /min
		3.94	8.66	.79	1.26	3.31	.99	36.6	.38				115 in ²	24.71 cfm
SDB-121/2	Male G1-1/4 BSP (ISO 228)	130	256	>25	50	2700	750	1000	288	SGB-120-03-B	Synthetic Fibre	3µm	2095 cm ²	1,50 m ³ /min
		5.12	10.08	>.98	1.98	5.92	1.65	61.0	.63				320 in ²	52.97 cfm
SDB-122/2	Male G1-1/4 BSP (ISO 228)	130	366	>25	50	4000	1500	2000	576	SGB-120-03-B	Synthetic Fibre	3µm	2095 cm ²	1,50 m ³ /min
		5.12	14.41	>.98	1.98	8.82	3.31	122.0	1.27				320 in ²	52.97 cfm

Characteristics

Combination of air breather and water removal filter

When a reservoir or gearbox breathes, air containing water vapor is ingested into the system. Temperature fluctuations will cause this water vapor to condense which can speed up the oxidation of the fluid and lead to damage in the system.

While inhaling, Desiccant Air Breathers SDB first dry the air as it passes through the drying agent. The air then passes through a 3µm air filter element to remove any solid contamination particles.

As moisture is absorbed, the drying agent will gradually change from red to orange. When it is orange, replace the drying agent. If required, an optional visual indicator gives an indication of the status of the air breather. With the moisture absorbed, the oxidation process can be decreased and the lifetime of the oil and the entire machinery will be extended.

Desiccant Air Breathers SDB can also be re-fitted with a layer of active carbon (1/3) and a layer of regular drying agent (2/3) for vapor filtration.

Features

- Available in 4 different sizes
- Diameter of Ø100 mm / Ø3.94 in or Ø130 mm / Ø5.12 in
- Refillable with drying agent (non-toxic ZR gel grain) or a mix of drying agent and active carbon
- Replaceable air filter element SGB
- Connection: Male BSP thread (ISO 228) on Stainless Steel tube
- Available with adaptor plate to simplify installation and to enable the use of a visual contamination indicator
- Operating temperature range: -40 °C ... +90 °C / -40 °F ... +194 °F*

Accessories / Spare Parts

Adaptor plate

- for SDB-093/2 and SDB-096/2: AP-1
- for SDB-121/2 and SDB-122/2: AP-2

Visual contamination indicator

- for all sizes (in conjunction with adaptor plate only): FM

Drying agent refilling material (supplied in air tight container)

- for SDB-093/2 (300 cm³ / 18.3 in³): RD-093
- for SDB-096/2 (600 cm³ / 26.6 in³): RD-096
- for SDB-121/2 (1000 cm³ / 61.0 in³): RD-121
- for SDB-122/2 (2000 cm³ / 122.0 in³): RD-122

Active carbon refilling material (supplied in air tight container)

- for SDB-093/2, SDB-096/2 and SDB-121/2 (300 cm³ / 18.3 in³): RC-093/096/121
- for SDB-122/2 (600 cm³ / 18.3 in³): RC-122

Please note: Use one layer of active carbon (1/3) and one layer of regular drying agent (2/3).

Replacement air filter element (sealing included)

- for SDB-093/2 and SDB-096/2: SGB-090-03-B
- for SDB-121/2 and SDB-122/2: SGB-120-03-B

Order Codes

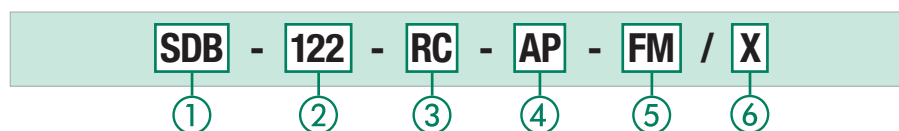

① Type

Desiccant Air Breather **SDB**

② Max. Water Absorption and Size

86 g / .19 lbs at Ø100 mm / Ø3.94 in	093
172 g / .38 lbs at Ø100 mm / Ø3.94 in	096
288 g / .63 lbs at Ø130 mm / Ø5.12 in	121
576 g / 1.27 lbs at Ø130 mm / Ø5.12 in	122

Please see table above for further technical details.

③ Drying Agent Material

Regular drying agent (standard option)	-
One layer of active carbon (1/3) and one layer of regular drying agent (2/3) for vapor filtration	RC

④ Adaptor Plate

Without adaptor plate	-
With adaptor plate	AP

⑤ Contamination Indicator

Without contamination indicator	-
With visual contamination indicator FM (in conjunction with adaptor plate AP only)	FM

Please see page 47 for details.

⑥ Design Code

Only for information	X
----------------------	----------

* Note: The operation of the Desiccant Air Breather may vary at temperatures below 0°C / 32°F due to very low humidity %.



Desiccant Air Breather (Disposable Version) Type SVDB

Drying Agent

Capable in changing colours with increasing moisture



This product does not contain any dangerous substances according to EC Council directives 99/45/EC and 2001/60/EC.

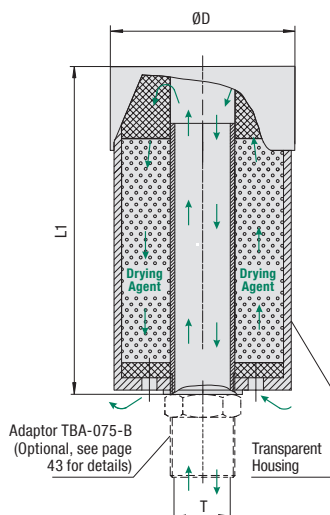

Dimensions and Technical Data

Type	Thread T	Dimensions (mm/in)			Weight (g/lbs)		Volume (cm ³ /in ³)	Max. Water Absorption (g/lbs)	Max. Air Flow Rate
		ØD	L1	L2	Complete Unit	Drying Agent	Drying Agent		
SVDB-093	Female G3/4 BSP (ISO 228)	94	109	18	400	225	300	86	0,70 m ³ /min
		3.70	4.68	.71	.88	.50	18.3	.19	24.71 cfm
SVDB-096	Female G3/4 BSP (ISO 228)	94	179	18	700	450	600	172	0,70 m ³ /min
		3.70	7.05	.71	1.54	.99	36.9	.38	24.71 cfm

Features

- Light-weight alternative to the SDB series
- Available in 2 different sizes
- Diameter of Ø94 mm / Ø3.70 in
- Filled with drying agent (non-toxic ZR gel grain)
- Connection: Female BSP thread (ISO 228) in Plastic housing
- Operating temperature range: -40 °C ... +90 °C / -40 °F ... +194 °F*

Please note that neither the air filter element nor the drying agent can be replaced when saturated.

Characteristics

Combination of air breather and water removal filter

When a reservoir or gearbox breathes, air containing water vapor is ingested into the system. Temperature fluctuations will cause this water vapor to condense which can speed up the oxidation of the fluid and lead to damage in the system.

Desiccant Air Breathers SVDB are the light-weight alternative to the proven SDB series, offering an almost identical filtration and absorption performance.

While inhaling, Desiccant Air Breathers SVDB also first dry the air as it passes through the drying agent. The air then passes through a 10 µm coarse filter to remove any solid contamination particles.

As moisture is absorbed, the drying agent will gradually change from red to orange. When it is orange, replace the entire unit. If required, an optional visual indicator gives an indication of the status of the air breather. With the moisture absorbed, the oxidation process can be decreased and the lifetime of the oil and the entire machinery will be extended.

Accessories / Spare Parts

Connection adaptor (see page 43 for details)

- for all sizes: **TBA-075-B**

Adaptor plate

- for all sizes (in conjunction with adaptor plate only): **AP-1**

Visual contamination indicator

- for all sizes (in conjunction with adaptor plate only): **FM**

Order Codes

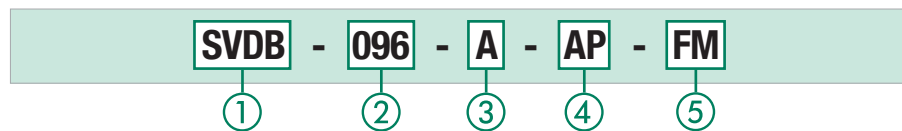

1 Type

Desiccant Air Breather (Economy Version) **SVDB**

2 Max. Water Absorption and Size

86 g / .19 lbs at Ø94 mm / Ø3.70 **093**

172 g / .38 lbs at Ø94 mm / Ø3.70 **096**

Please see table above for further technical details.

3 Connection Adaptor

Without connection adaptor -

With connection adaptor TBA-075-B **A**

Please see page 43 for details.

Contact STAUFF for alternative adaptors.

4 Adaptor Plate

Without adaptor plate -

With adaptor plate (in conjunction with connection adaptor A only) **AP**

5 Contamination Indicator

Without contamination indicator -

With visual contamination indicator FM (in conjunction with adaptor plate AP only) **FM**

Please see page 47 for details.

* Note: The operation of the Desiccant Air Breather may vary at temperatures below 0°C / 32°F due to very low humidity %.



Desiccant Air Breather with Check Valves Type SDB-CV

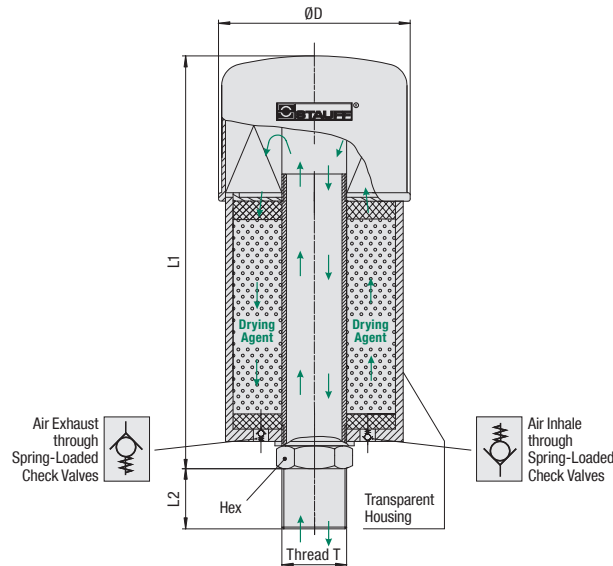

Drying Agent
Capable in changing colours
with increasing moisture



This product does not contain any dangerous substances according to EC Council directives 99/45/EC and 2001/60/EC.

Dimensions and Technical Data

Type	Thread T	Dimensions (mm/in)				Weight (g/lbs)		Volume (cm ³ /in ³)		Max. Water Absorption (g/lbs)	Air Filter Elements	Filter 67	Micron Rating	Filter Surface	Max. Air Flow Rate
		ØD	L1	L2	Hex	Complete Unit	Drying Agent	Drying Agent	Drying Agent						
SDB-061-CV	Female G3/8	68	143	14	22	350	75	100	29	SGB-060-03-B	Synthetic Fibre	3µm	415 cm ²	0,05 m ³ /min	
	BSP (ISO 228)	2.68	5.63	.55	.87	.77	.17	6.1	.06						63 in ²
SDB-096-CV	Male G3/4	100	220	20	32	1500	450	600	172	SGB-090-03-B	Synthetic Fibre	3µm	752 cm ²	0,70 m ³ /min	
	BSP (ISO 228)	3.94	8.66	.79	1.26	3.31	.99	36.6	.38						115 in ²
SDB-121-CV	Male G1-1/4	130	256	>25	50	2700	750	1000	288	SGB-120-03-B	Synthetic Fibre	3µm	2095 cm ²	1,50 m ³ /min	
	BSP (ISO 228)	5.12	10.08	>.98	1.98	5.92	1.65	61.0	.63						320 in ²
SDB-122-CV	Male G1-1/4	130	366	>25	50	4000	1500	2000	576	SGB-120-03-B	Synthetic Fibre	3µm	2095 cm ²	1,50 m ³ /min	
	BSP (ISO 228)	5.12	14.41	>.98	1.98	8.82	3.31	122.0	1.27						320 in ²

Characteristics

Combination of air breather and water removal filter with integrated check valves to increase the lifetime of the desiccant material; particularly suited for gearbox applications

When a reservoir or gearbox breathes, air containing water vapor is ingested into the system. Temperature fluctuations will cause this water vapor to condense which can speed up the oxidation of the fluid and lead to damage in the system.

While inhaling, Desiccant Air Breathers SDB-CV first dry the air as it passes through the drying agent. The air then passes through a 3µm air filter element to remove any solid contamination particles.

Thanks to the spring-loaded check valves with an opening pressure of 0,01 bar / .15PSI, the drying agent will be isolated from the atmosphere unless inhaling or exhaling, which increases the lifetime of the Desiccant Air Breather SDB-CV as well.

As moisture is absorbed, the drying agent will gradually change from red to orange. When it is orange, replace the drying agent. If required, an optional visual indicator (not for the SDB-061-CV) gives an indication of the status of the air breather. With the moisture absorbed, the oxidation process can be decreased and the lifetime of the oil and the entire machinery will be extended. Desiccant Air Breathers SDB-CV can also be re-fitted with a layer of active carbon (1/3) and a layer of regular drying agent (2/3) for vapor filtration.

Features

- Available in 4 different sizes with diameter of Ø68 mm / Ø2.68 in, Ø100 mm / Ø3.94 in or Ø130 mm / Ø5.12 in
- Equipped with spring-loaded check valves in opposing directions with an opening pressure of 0,01 bar / .15PSI
- Refillable with drying agent (non-toxic ZR gel grain) or a mix of drying agent and active carbon
- Replaceable air filter element SGB
- Connection: BSP thread (ISO 228)
- Operating temperature range: -40 °C ... +90 °C / -40 °F ... +194 °F*

Please note: Using an Desiccant Air Breather with integrated spring-loaded check valves may cause an under or over pressure of 0,01 bar / .15PSI inside the system, which does not cause any problems for the majority of gearboxes and reservoirs. In case of doubt, please contact your equipment supplier.

Accessories / Spare Parts

Adaptor plate

- for SDB-096-CV: **AP-1**
- for SDB-121-CV and SDB-122-CV: **AP-2**

Visual contamination indicator

- for SDB-096-CV, SDB-121-CV and SDB-122-CV (in conjunction with adaptor plate only): **FM**

Drying agent refilling material (supplied in air tight container)

- for SDB-061-CV (100 cm³ / 6.1 in³): **RD-061**
- for SDB-096-CV (600 cm³ / 26.6 in³): **RD-096**
- for SDB-121-CV and SDB-122-CV (1000 cm³ / 61.0 in³): **RD-121**
- for SDB-122-CV (2000 cm³ / 122.0 in³): **RD-122**

Active carbon refilling material (supplied in air tight container)

- for SDB-096-CV and SDB-121-CV (300 cm³ / 18.3 in³): **RC-093/096/121**
- for SDB-122-CV (600 cm³ / 18.3 in³): **RC-122**

Please note: Use one layer of active carbon (1/3) and one layer of regular drying agent (2/3).

Replacement air filter element (sealing included)

- for SDB-061-CV: **SGB-060-03-B**
- for SDB-096-CV: **SGB-090-03-B**
- for SDB-121-CV and SDB-122-CV: **SGB-120-03-B**

Order Codes

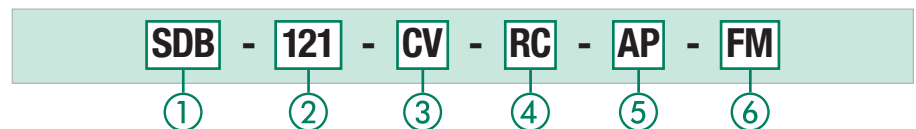

1 Type

Desiccant Air Breather **SDB**

2 Max. Water Absorption and Size

29g / .06 lbs at Ø68 mm / Ø2.68 in **061**
 172g / .38 lbs at Ø100 mm / Ø3.94 in **096**
 288g / .63 lbs at Ø130 mm / Ø5.12 in **121**
 576g / 1.27 lbs at Ø130 mm / Ø5.12 in **122**

Please see table above for further technical details.

3 Check Valves

With integrated spring-loaded check valves (0,01 bar / .15PSI) **CV**

4 Drying Agent

Regular drying agent (standard option) **-**
 One layer of active carbon (1/3) and one layer of regular drying agent (2/3) for vapor filtration **RC**

5 Adaptor Plate

Without adaptor **-**
 With adaptor plate (not for SDB-061-CV) **AP**

6 Contamination Indicator

Without contamination indicator **-**
 With visual contamination indicator FM (in conjunction with adaptor plate AP only) **FM**

Please see page 47 for details.

* Note: The operation of the Desiccant Air Breather may vary at temperatures below 0°C / 32°F due to very low humidity %.



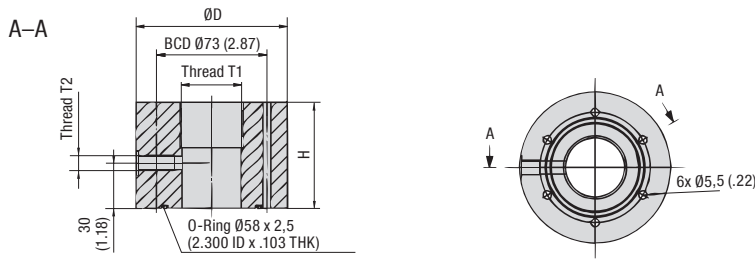

Adaptor Plate Type AP



Desiccant Air Breather SDB with Adaptor Plate AP

Order Code and Dimensions

Thread T1 (Breather Port)	Thread T2 (Indicator Port)	Dimensions (mm/in)		Socket Cap Screws included	For Use with Desiccant Air Breathers	Order Code
		H	ØD			
Female G3/4 BSP (ISO 228)	Female G1/8 BSP (ISO 228)	50	88	M5 x 60 - 8.8 (Steel, zinc-plated)	SDB-096/2 SDB-093/2 SVDB-096 SVDB-093 SDB-096-CV	AP-1
		1.98	3.46			
Female G1-1/4 BSP (ISO 228)	Female G1/8 BSP (ISO 228)	70	100	M5 x 80 - 8.8 (Steel, zinc-plated)	SDB-121/2 SDB-122/2 SDB-121-CV SDB-122-CV	AP-2
		2.76	3.94			

Characteristics

Designed to simplify the installation of Desiccant Air Breathers and enable the use of a visual contamination indicator

With Adaptor Plates AP, desiccant air breathers can be directly mounted to existing connections with a six-hole bolt pattern for flange interfaces similar to DIN 24557, part 2.

They are also equipped with a female G1/8 BSP thread (ISO 228) to connect with the Visual Contamination Indicator FM.

Adaptor Plates AP are made of Polyamide (PA). A blind plug, O-ring made of NBR (Buna-N®) and 6 socket cap screws (ISO 4762) are supplied with AP as a standard.

Contact STAUFF for other Adaptor Plates.

Visual Contamination Indicator Type FM

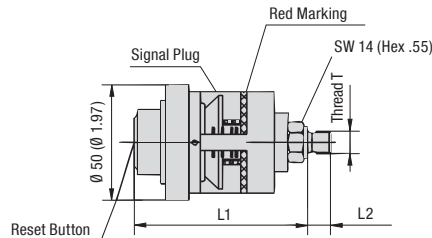

Desiccant Air Breather SDB with Adaptor Plate AP and Visual Contamination Indicator FM



Order Code and Dimensions

Thread T	Dimensions (mm/in)		Order Code
	L1	L2	
Male G1/8 BSP (ISO 228)	75	10	FM
	2.54	.39	

Materials

- Housing made of Polycarbonate

Technical Data

- Operating temperature range: -40 °C ... +121 °C (-40 °F ... +250 °F)
- Accuracy: ±10% at red marking

Characteristics

Designed to indicate the status of air filter elements

Visual Contamination Indicators FM – the so-called Filter Minders® – are connected to the female G1/8 BSP thread (ISO 228) of the Adaptor Plate AP and give a visual indication of the contamination level of the air filter element SGB. A red marking indicates when the air filter element has to be replaced.

Visual Contamination Indicators FM can be reset afterwards.

Order Code and Dimensions

Dimensions (mm/in)		Order Code
Length	Diameter	
140	60	TBA-075-B-OD140
5.51	2.36	
210	60	TBA-075-B-OD210
8.27	2.36	

Dimensional drawings: All dimensions in mm (in).

Characteristics

Designed to prevent oil mist from leaving the hydraulic reservoir through air breathers

Features

- Available in 2 different sizes with lengths of 140 mm / 5.51 in or 210 mm / 8.27 in
- Suitable for use with various types of Desiccant Air Breathers including SDB-096/2, SDB-093/2, SVDB-096, SVDB-093 and SDB-096-CV as well as Tank Filler Breathers including SPB-2, SPB-3, SMBT-80 and SPBN

Materials

- Housing with cooling ribs made of Aluminum housing with cooling ribs
- Threaded adaptors made of Steel

Oil Demister Type TBA-OD

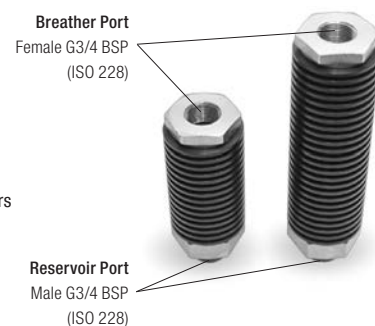



Suction Strainers 48 - 51



SUS (Polyamide End Cap) 50



SUS (Aluminium End Cap) 51

D



Suction Strainer (Polyamide End Cap) Type SUS

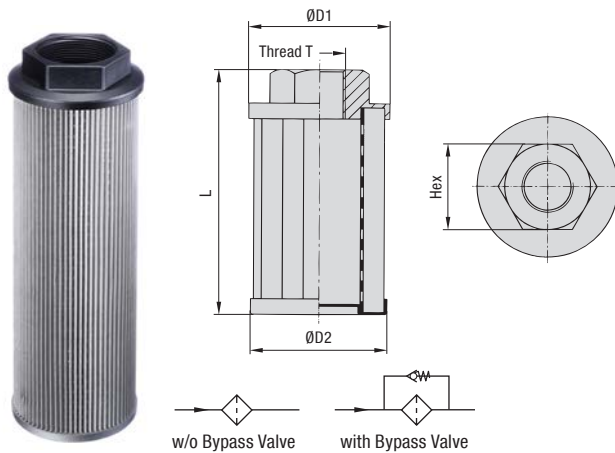

Flow Characteristics

Nominal Flow Rate vs. Pressure Drop ΔP

The following characteristics are valid for Mineral oils with a mass density of 0,85 kg/dm³ and a kinematic viscosity of 30 mm²/s (cSt) at +38 °C / +100 °F.

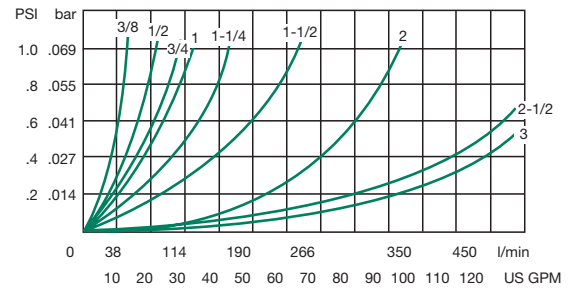

Characteristics

Designed as in-tank suction strainer elements for direct installation into suction lines of pumps; should always be installed below the minimum fluid level of the reservoir

Features

- Available with female BSP thread (ISO 228) or female NPT thread (ANSI B1.20.1)
- Operating temperature range: -20 °C ... +100 °C / -4 °F ... +212 °F

Media Compatibility

- Suitable for use with Mineral and Petroleum based hydraulic fluids (HL and HLP)

Materials

- Threaded end cap made of glass-fibre reinforced Polyamide (PA); see page 51 for version with Aluminium end cap
- Lower end cap and support tube made of Steel, zinc-plated
- Standard filter material is Stainless Steel Mesh (125 µm); alternative micron ratings of 60 µm and 250 µm on request

Options

- Integrated bypass valve with an opening pressure of 0,2 bar (3 PSI) to reduce the risks of high-pressure drops that can be caused by contaminated strainer elements or high-viscosity fluids

Special sizes, designs, materials and configurations are available on request. Contact STAUFF for details.

Contact STAUFF for alternative materials.

Dimensions and Technical Data (Female BSP Threaded Version)

Group Size	Thread T	Dimensions (mm/in)				Filter Surface	Max. Flow Rate
		ØD1	ØD2	L	Hex		
040-G06-075	G3/8 BSP	39,5	38,5	75	22	279 cm ²	12 l/min
		1.56	1.53	2.93	.87	43 in ²	3.1 US GPM
050-G06-067	G3/8 BSP	50	49	67	26	296 cm ²	12 l/min
		1.97	1.93	2.64	1.02	46 in ²	3.1 US GPM
050-G08-105	G1/2 BSP	50	49	105	26	518 cm ²	15 l/min
		1.97	1.93	4.13	1.02	80 in ²	3.9 US GPM
068-G12-105	G3/4 BSP	68	66	105	34	676 cm ²	25 l/min
		2.68	2.60	4.13	1.34	105 in ²	6.5 US GPM
068-G16-140	G1 BSP	68	66	140	42	930 cm ²	50 l/min
		2.68	2.60	5.51	1.65	144 in ²	13.0 US GPM
088-G20-140	G1-1/4 BSP	88	85	140	50	1172 cm ²	65 l/min
		3.46	3.35	5.51	1.97	182 in ²	16.9 US GPM
088-G24-140	G1-1/2 BSP	88	85	140	60	1172 cm ²	140 l/min
		3.46	3.35	5.51	2.36	182 in ²	36.4 US GPM
102-G24-200	G1-1/2 BSP	102	100	200	72	2427 cm ²	140 l/min
		4.02	3.94	7.87	2.83	376 in ²	36.4 US GPM
102-G32-200	G2 BSP	102	100	200	72	2427 cm ²	230 l/min
		4.02	3.94	7.87	2.83	376 in ²	59.8 US GPM
102-G32-225	G2 BSP	102	100	225	72	2811 cm ²	230 l/min
		4.02	3.94	8.86	2.83	436 in ²	59.8 US GPM
102-G32-260	G2 BSP	102	100	260	72	3249 cm ²	230 l/min
		4.02	3.94	10.24	2.83	504 in ²	59.8 US GPM
102-G32-300	G2 BSP	102	100	300	72	3798 cm ²	230 l/min
		4.02	3.94	11.81	2.83	589 in ²	59.8 US GPM
131-G40-191	G2-1/2 BSP	131	128	191	86	2430 cm ²	340 l/min
		5.16	5.04	10.24	3.39	377 in ²	88.4 US GPM
131-G40-212	G2-1/2 BSP	131	128	212	86	2748 cm ²	340 l/min
		5.16	5.04	8.35	3.39	426 in ²	88.4 US GPM
131-G48-272	G3 BSP	131	128	272	96	3626 cm ²	400 l/min
		5.16	5.04	10.71	3.78	562 in ²	104 US GPM
150-G32-151	G2 BSP	150	145	151	70	1812 cm ²	400 l/min
		5.91	5.71	5.94	2.76	281 in ²	104 US GPM

Dimensions and Technical Data (Female NPT Threaded Version)

Group Size	Thread T	Dimensions (mm/in)				Filter Surface	Max. Flow Rate
		ØD1	ØD2	L	Hex		
050-N06-067	3/8 NPT	50	49	67	26	296 cm ²	12 l/min
		1.97	1.93	2.64	1.02	46 in ²	3.1 US GPM
050-N06-090	3/8 NPT	50	49	90	26	430 cm ²	12 l/min
		1.97	1.93	3.54	1.02	67 in ²	3.1 US GPM
050-N08-105	1/2 NPT	50	49	105	26	518 cm ²	15 l/min
		1.97	1.93	4.13	1.02	80 in ²	3.9 US GPM
068-N12-105	3/4 NPT	68	66	105	34	676 cm ²	25 l/min
		2.68	2.60	4.13	1.34	105 in ²	6.5 US GPM
068-N16-140	1 NPT	68	66	140	42	930 cm ²	50 l/min
		2.68	2.60	5.51	1.65	144 in ²	13.0 US GPM
088-N20-140	1-1/4 NPT	88	85	140	50	1172 cm ²	65 l/min
		3.46	3.35	5.51	1.97	182 in ²	16.9 US GPM
088-N20-195	1-1/4 NPT	88	85	195	60	1709 cm ²	65 l/min
		3.46	3.35	7.68	2.36	265 in ²	16.9 US GPM
088-N24-140	1-1/2 NPT	88	85	140	60	1172 cm ²	140 l/min
		3.46	3.35	5.51	2.36	182 in ²	36.4 US GPM
088-N24-226	1-1/2 NPT	88	85	226	60	2012 cm ²	140 l/min
		3.46	3.35	8.90	2.36	312 in ²	36.4 US GPM
088-N24-260	1-1/2 NPT	88	85	260	60	2344 cm ²	140 l/min
		3.46	3.35	10.24	2.36	363 in ²	36.4 US GPM
102-N24-200	1-1/2 NPT	102	100	200	72	2427 cm ²	140 l/min
		4.02	3.94	7.87	2.83	376 in ²	36.4 US GPM
102-N32-260	2 NPT	102	100	260	72	3249 cm ²	230 l/min
		4.02	3.94	10.24	2.83	504 in ²	59.8 US GPM
131-N40-212	2-1/2 NPT	131	128	212	86	2748 cm ²	340 l/min
		5.16	5.04	8.35	3.39	426 in ²	88.4 US GPM
131-N48-272	3 NPT	131	128	272	96	3626 cm ²	400 l/min
		5.16	5.04	10.71	3.78	562 in ²	104 US GPM



Suction Strainer (Aluminium End Cap) Type SUS

Flow Characteristics

Nominal Flow Rate vs. Pressure Drop ΔP

The following characteristics are valid for Mineral oils with a mass density of 0,85 kg/dm³ and a kinematic viscosity of 30 mm²/s (cSt) at +38 °C / +100 °F.

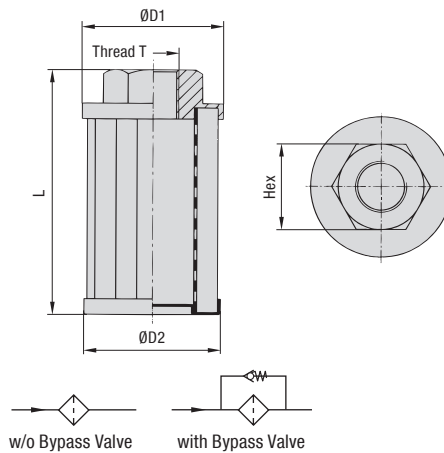
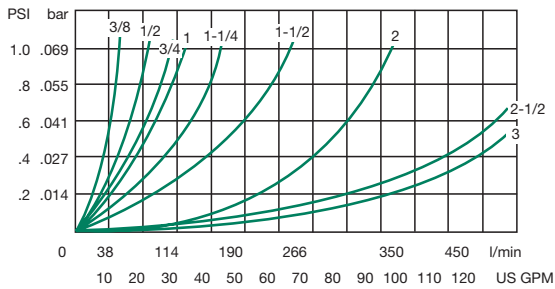

Characteristics

Designed as in-tank suction strainer elements for direct installation into suction lines of pumps; should always be installed below the minimum fluid level of the reservoir

Features

- Available with female NPT thread (ANSI B1.20.1)
- Operating temperature range: -20 °C ... +100 °C / -4 °F ... +212 °F

Media Compatibility

- Suitable for use with Mineral and Petroleum based hydraulic fluids (HL and HLP)

Materials

- Threaded end cap made of Aluminium; see page 50 for version with Polyamide (PA) end cap
- Lower end cap and support tube made of Steel, zinc-plated
- Filter material made of Stainless Steel Mesh (125 µm); alternative micron ratings of 60 µm and 250 µm on request

Contact STAUFF for alternative materials.

Options

- Integrated bypass valve with an opening pressure of 0,2 bar (3 PSI) to reduce the risks of high-pressure drops that can be caused by contaminated strainer elements or high-viscosity fluids

Special sizes, designs, materials and configurations are available on request. Contact STAUFF for details.

Dimensions and Technical Data (Female NPT Threaded Version)

Group Size	Thread T	Dimensions (mm/in)				Filter Surface	Max. Flow Rate
		ØD1	ØD2	L	Hex		
050-N06-067	3/8 NPT	50	49	67	26	296 cm ²	12 l/min
		1.97	1.93	2.64	1.02	46 in ²	3.1 US GPM
050-N06-090	3/8 NPT	50	49	90	26	430 cm ²	12 l/min
		1.97	1.93	3.54	1.02	67 in ²	3.1 US GPM
050-N08-105	1/2 NPT	50	49	105	26	518 cm ²	15 l/min
		1.97	1.93	4.13	1.02	80 in ²	3.9 US GPM
068-N12-105	3/4 NPT	68	66	105	34	676 cm ²	25 l/min
		2.68	2.60	4.13	1.34	105 in ²	6.5 US GPM
068-N16-140	1 NPT	68	66	140	42	930 cm ²	50 l/min
		2.68	2.60	5.51	1.65	144 in ²	13.0 US GPM
088-N20-140	1-1/4 NPT	88	85	140	50	1172 cm ²	65 l/min
		3.46	3.35	5.51	1.97	182 in ²	16.9 US GPM
088-N20-195	1-1/4 NPT	88	85	195	60	1709 cm ²	65 l/min
		3.46	3.35	7.68	2.36	265 in ²	16.9 US GPM
088-N24-140	1-1/2 NPT	88	85	140	60	1172 cm ²	140 l/min
		3.46	3.35	5.51	2.36	182 in ²	36.4 US GPM
088-N24-226	1-1/2 NPT	88	85	226	60	2012 cm ²	140 l/min
		3.46	3.35	8.90	2.36	312 in ²	36.4 US GPM
088-N24-260	1-1/2 NPT	88	85	260	60	2344 cm ²	140 l/min
		3.46	3.35	10.24	2.36	363 in ²	36.4 US GPM
088-N32-260	2 NPT	88	85	260	70	2344 cm ²	230 l/min
		3.46	3.35	10.24	2.76	363 in ²	59.8 US GPM
150-N40-213	2-1/2 NPT	150	145	213	90	2741 cm ²	340 l/min
		5.91	5.71	8.39	3.54	425 in ²	88.4 US GPM
150-N48-272	3 NPT	150	145	272	100	3625 cm ²	400 l/min
		5.91	5.71	10.71	3.94	562 in ²	104 US GPM

Order Codes



① Type

Suction Strainer for direct installation into suction lines of pumps

SUS

② Group Size

Select 'Group Size' from corresponding column in dimensional tables

The group size is defined by the diameter ØD1 of the threaded end cap, the thread code (type and size) and the total length of the suction strainer element (e.g. 040-B06F-075).

③ Filter Material / Micron Rating

Stainless Steel Mesh, 125 µm (standard option)

125

Stainless Steel Mesh, 60 µm

060

Stainless Steel Mesh, 250 µm

250

Contact STAUFF for alternative materials / micron ratings.

④ Material of Threaded End Cap

Glass-fibre reinforced Polyamide

P

Aluminium (for female NPT threaded version only)

A

⑤ Bypass Option

Without bypass valve (standard option)

0

Integrated bypass valve with opening pressure of 0,2 bar (3 PSI)

B0.2





Diffusors

52 - 55



SRV (Female BSP Threaded Version)

54



SRV (Female NPT Threaded Version)

55



Diffuser Type SRV (Female BSP Threaded Version)

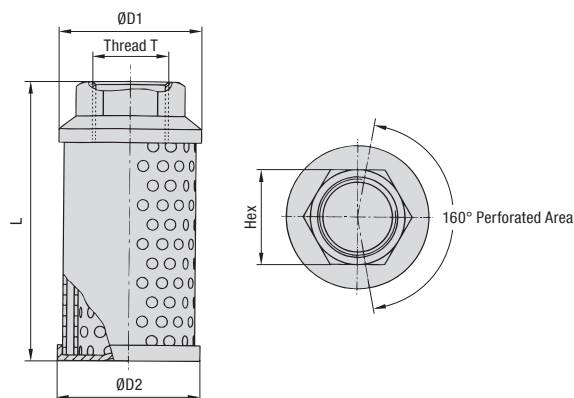

Installation

Installation below the minimum fluid level of the reservoir with the plain area facing the pump inlet

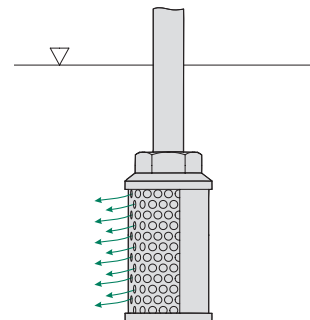

E

Characteristics

Designed for direct installation into return lines to reduce fluid aeration, foaming and noise; should always be installed below the minimum fluid level

Features

- Available with female BSP thread (ISO 228)
- Operating temperature range:
-20 °C ... +100 °C / -4 °F ... +212 °F
- Max. working pressure: 20 bar / 290 PSI

Media Compatibility

- Suitable for use with Mineral and Petroleum based hydraulic fluids (HL and HLP)

Construction and Materials

- 2 concentric tubes with inner spaced holes
- Threaded end cap made of Aluminium
- Other components made of Steel, zinc-plated

Special sizes, designs, materials and configurations are available on request. Contact STAUFF for details.

Dimensions and Order Codes (Female BSP Threaded Version)

Thread T	Dimensions (mm/in)				Max. Flow Rate
	ØD1	ØD2	L	Hex	
G3/4	64	62	109	36	50 l/min
	2.52	2.44	4.29	1.42	13 US GPM
G1	64	62	139	46	114 l/min
	2.52	2.44	5.47	1.81	30 US GPM
G1-1/4	86	84	139	60	200 l/min
	3.39	3.31	5.47	2.36	52 US GPM
G1-1/2	86	84	200	60	227 l/min
	3.39	3.31	7.87	2.36	59 US GPM
G2	86	84	260	70	454 l/min
	3.39	3.31	10.24	2.76	118 US GPM
G2-1/2	150	148	212	90	650 l/min
	5.91	5.83	8.35	3.54	169 US GPM
G3	150	148	272	100	950 l/min
	5.91	5.83	10.71	3.94	247 US GPM

Order Codes

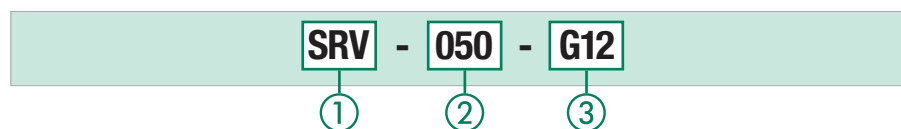

Diffusers SRV are ideally suited for use with STAUFF Return Line Filters of the RF series with threaded connection.

For details, please see Catalogue 9 - STAUFF Filtration Technology.

① Type

Diffuser **SRV**

② Max. Flow Rate

50 l/min / 13 US GPM	050
114 l/min / 30 US GPM	114
200 l/min / 52 US GPM	200
227 l/min / 59 US GPM	227
454 l/min / 118 US GPM	454
650 l/min / 169 US GPM	650
950 l/min / 247 US GPM	950

③ Connection Thread (Female)

G3/4	G12
G1	G16
G1-1/4	G20
G1-1/2	G24
G2	G32
G2-1/2	G40
G3	G48

Contact STAUFF for alternative threads.



Diffuser Type SRV (Female NPT Threaded Version)

Installation

Installation below the minimum fluid level of the reservoir with the plain area facing the pump inlet

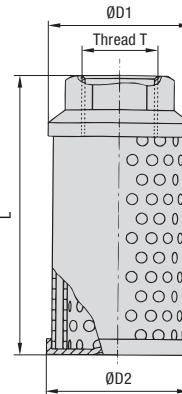
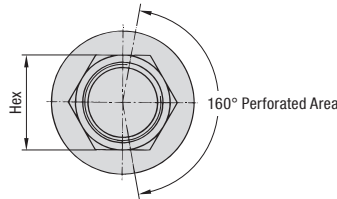
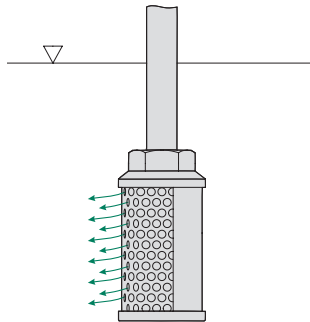

Dimensions and Order Codes (Female NPT Threaded Version)

Thread T	Dimensions (mm/in)			Hex	Max. Flow Rate
	ØD1	ØD2	L		
3/4 NPT	64	62	109	36	50 l/min
	2.52	2.44	4.29	1.42	13 US GPM
1 NPT	64	62	139	46	114 l/min
	2.52	2.44	5.47	1.81	30 US GPM
1-1/4 NPT	86	84	139	60	200 l/min
	3.39	3.31	5.47	2.36	52 US GPM
1-1/2 NPT	86	84	200	60	227 l/min
	3.39	3.31	7.87	2.36	59 US GPM
2 NPT	86	84	260	70	454 l/min
	3.39	3.31	10.24	2.76	118 US GPM
2-1/2 NPT	150	148	212	90	650 l/min
	5.91	5.83	8.35	3.54	169 US GPM
3 NPT	150	148	272	100	950 l/min
	5.91	5.83	10.71	3.94	247 US GPM

Characteristics

Designed for direct installation into return lines to reduce fluid aeration, foaming and noise; should always be installed below the minimum fluid level

Features

- Available with female NPT thread (ANSI B1.20.1)
- Operating temperature range: -20 °C ... +100 °C / -4 °F ... +212 °F
- Max. working pressure: 20 bar / 290 PSI

Media Compatibility

- Suitable for use with Mineral and Petroleum based hydraulic fluids (HL and HLP)

Construction and Materials

- 2 concentric tubes with inner spaced holes
- Threaded end cap made of Aluminium
- Other components made of Steel, zinc-plated

Special sizes, designs, materials and configurations are available on request. Contact STAUFF for details.

Order Codes

SRV - 050 - N12

①

②

③

① Type

Diffuser **SRV**

② Max. Flow Rate

50 l/min / 13 US GPM	050
114 l/min / 30 US GPM	114
200 l/min / 52 US GPM	200
227 l/min / 59 US GPM	227
454 l/min / 118 US GPM	454
650 l/min / 169 US GPM	650
950 l/min / 247 US GPM	950

③ Connection Thread (Female)

3/4 NPT	N12
1 NPT	N16
1-1/4 NPT	N20
1-1/2 NPT	N24
2 NPT	N32
2-1/2 NPT	N40
3 NPT	N48

Contact STAUFF for alternative threads.



Diffusers SRV are ideally suited for use with STAUFF Return Line Filters of the RF series with threaded connection.

For details, please see Catalogue 9 -STAUFF Filtration Technology.



E

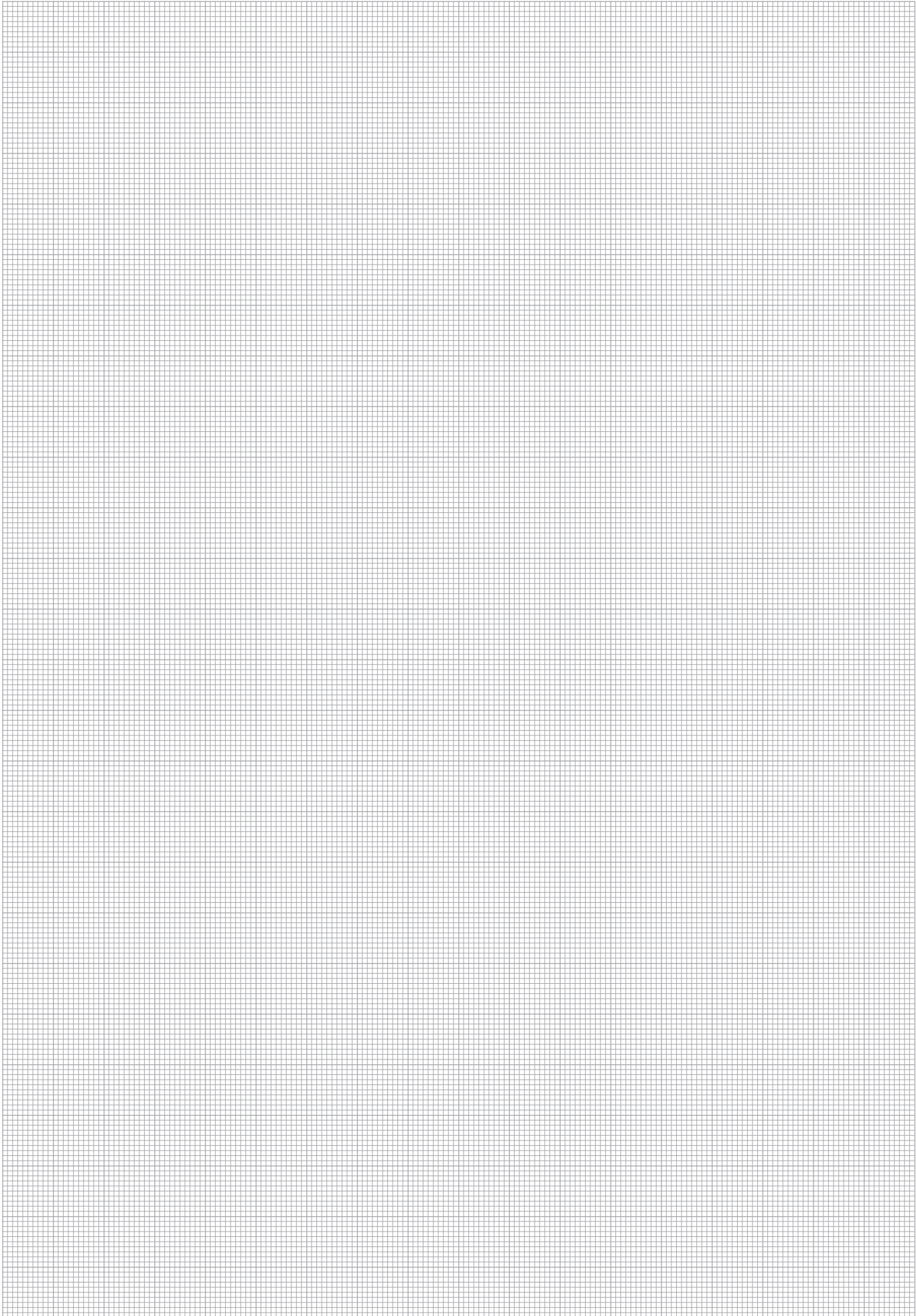

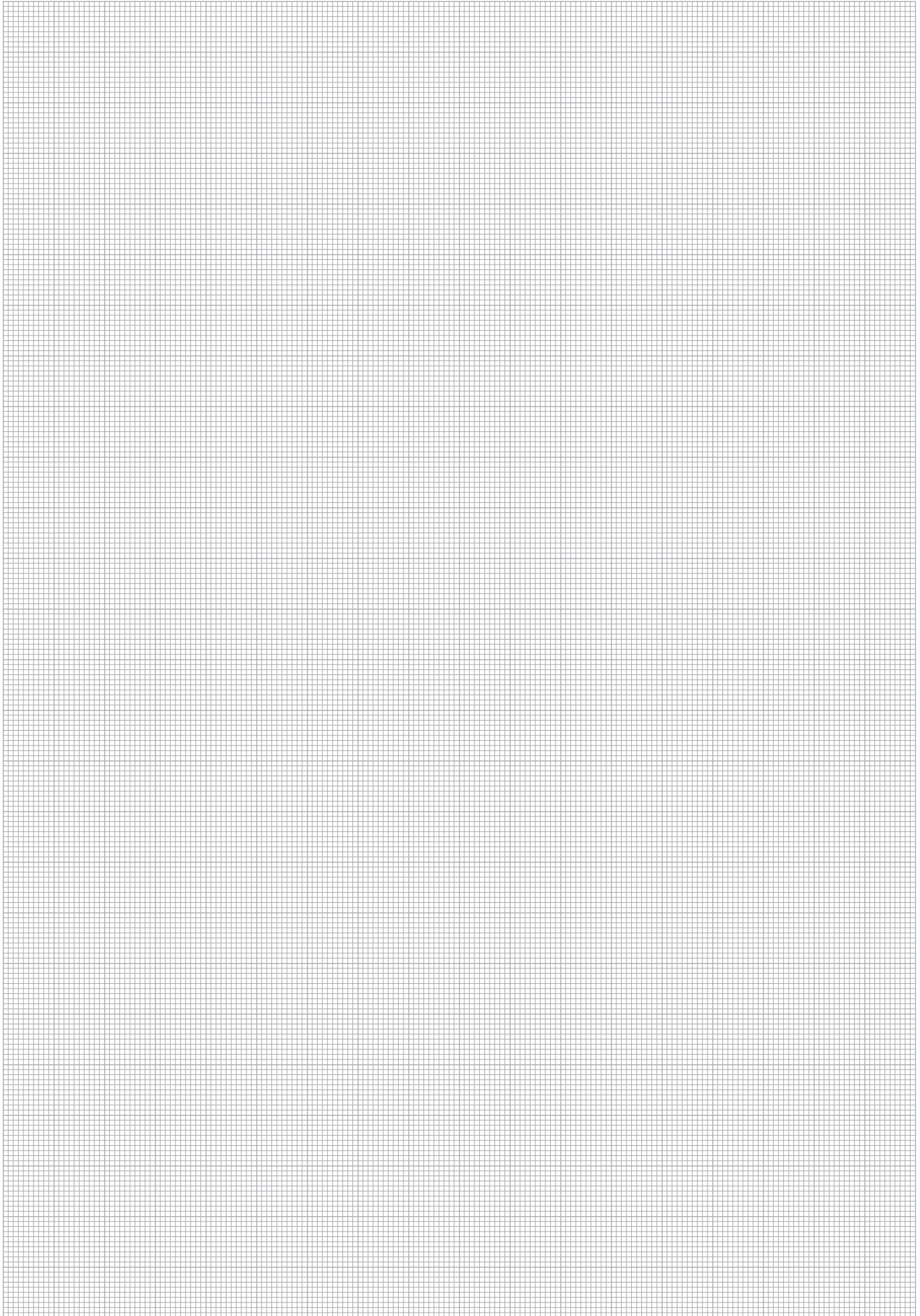



Product-Specific Abbreviations	60
Global Contact Directory	62 - 63



Product-Specific Abbreviations

Abbreviation	Product Category	Product Description	Page
AP	Giant and Desiccant Air Breathers	Adaptor Plate	47
ASMB-1	Tank Filler Breathers	Side Mount Bracket (Polyamide Version)	38
ASMB-2	Tank Filler Breathers	Side Mount Bracket (Aluminium Version)	38
DT04-4P	Fluid Level and Temperature Indicators	Deutsch Adaptor Cable	20
EBF	Tank Filler Breathers	Extended Bayonet Flange	39
FM	Giant and Desiccant Air Breathers	Visual Contamination Indicator	47
SDB	Giant and Desiccant Air Breathers	Desiccant Air Breathers	44
SDB-CV	Giant and Desiccant Air Breathers	Desiccant Air Breathers (with Check Valves)	46
SDV-SNA / SNK	Fluid Level and Temperature Indicators	Anti-Drain Valve	20
SES	Tank Filler Breathers	Plastic Filler Breather (Threaded Version)	31
SES	Tank Filler Breathers	Plastic Filler Breather (Welded Version)	31
SGB	Giant and Desiccant Air Breathers	Giant Air Breather	42
SLTS	Fluid Level and Temperature Indicators	Level-Temperature Switch	21
SMBB-47	Tank Filler Breathers	Metal Filler Breather (Bayonet Version)	33
SMBB-80	Tank Filler Breathers	Metal Filler Breather (Bayonet Version)	35
SMBL	Tank Filler Breathers	Lockable Metal Filler Breather (Clamping, Threaded and Push-On Version)	37
SMBP-80	Tank Filler Breathers	Metal Filler Breather (Push-On Version)	36
SMBT-47	Tank Filler Breathers	Metal Filler Breather (Threaded Version)	32
SMBT-80	Tank Filler Breathers	Metal Filler Breather (Threaded Version)	34
SNA	Fluid Level and Temperature Indicators	Level Gauge	14
SNK	Fluid Level and Temperature Indicators	Level Gauge	16
SNKK	Fluid Level and Temperature Indicators	Level Gauge	17
SPB-1 / 2 / 3	Tank Filler Breathers	Plastic Filler Breather (Threaded Version)	24
SPB-4 / 5	Tank Filler Breathers	Plastic Filler Breather (Flange Version)	25
SPBM	Tank Filler Breathers	Plastic Filler Breather Mini (Threaded Version)	30
SPBN	Tank Filler Breathers	Plastic Filler Breather (Compact Design; Threaded Version)	28
SPBN	Tank Filler Breathers	Plastic Filler Breather (Compact Design; Bayonet Version)	28
SRV	Diffusors	Diffusors (Female BSP Threaded Version)	54
SRV	Diffusors	Diffusors (Female NPT Threaded Version)	55
SUS	Suction Strainers	Suction Strainers (Polyamide End Cap)	50
SUS	Suction Strainers	Suction Strainers (Aluminium End Cap)	51
SVDB	Giant and Desiccant Air Breathers	Desiccant Air Breathers (Disposable Version)	45
T1 / T2	Fluid Level and Temperature Indicators	Dial Thermometer with Probe	18
TBA	Giant and Desiccant Air Breathers	Air Breather Adaptor	43
TBA-OD	Giant and Desiccant Air Breathers	Oil Demister	47
TS	Fluid Level and Temperature Indicators	Thermo Switch	18
TS-SNA / SNK-PT100	Fluid Level and Temperature Indicators	Temperature Sensor	19
TS-SNA / SNK-PT100-T	Fluid Level and Temperature Indicators	Temperature Sensor with Direct Installation Set	19
WR	Tank Filler Breathers	Weld Riser	39



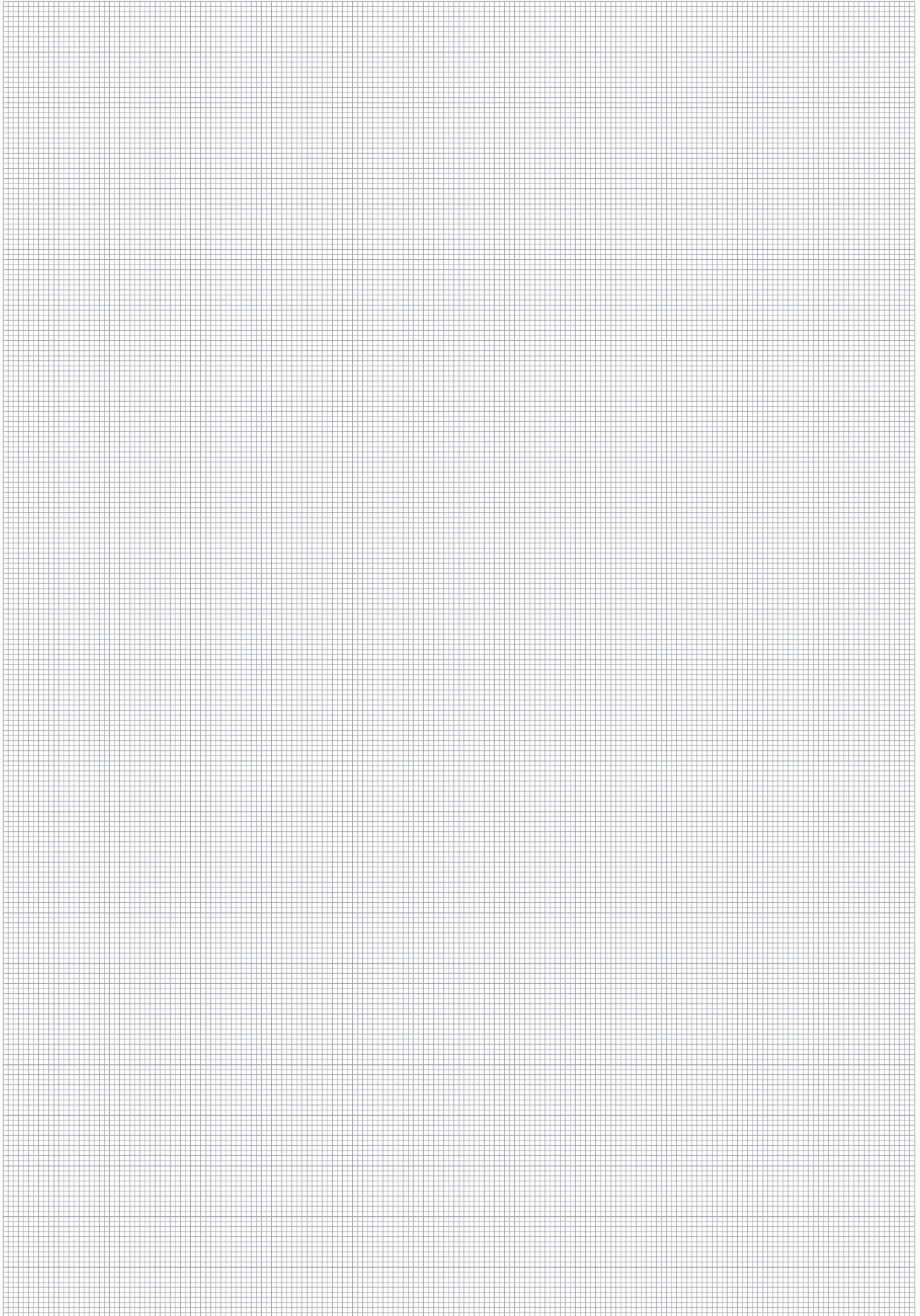

Global Contact Directory

STAUFF products and services are globally available through wholly-owned subsidiaries and a tight network of authorised distributors and representatives in all major industrial regions of the world.

Contact information on this page may be subject to changes and additions over time. Frequently updated and complete contact information can always be found at www.stauff.com.

Germany



Walter Stauffenberg GmbH & Co. KG

Im Ehrenfeld 4
58791 Werdohl
Tel.: +49 2392 91 60
Fax: +49 2392 91 61 60
E-Mail: sales@stauff.com
www.stauff.com



Neuenrade-Küntrop Logistics Centre
Wasserburgstraße 35
58809 Neuenrade



Plettenberg-Ohle Production Site
Lennestraße 2
58840 Plettenberg



Voswinkel GmbH

Neugrünenthal
58540 Meinerzhagen
Tel.: +49 2354 70 50
Fax: +49 2354 70 51 50
E-Mail: info@voswinkel.net
www.voswinkel.net

Europe

France

STAUFF S.A.S.
230, Avenue du Grain d'Or
Z.I. de Vineuil - Blois Sud
41354 Vineuil-cedex
Tel.: +33 2 54 50 55 50
Fax: +33 2 54 42 29 19
E-Mail: direction@stauffsa.com
www.stauff.fr

Ireland

STAUFF UK Ltd.
Block B, 9 Ferguson Drive
Knockmore Hill Industrial Estate
Lisburn, County Antrim, BT28 2EX
Tel.: +44 2892 60 69 00
Fax: +44 2892 60 26 88
E-Mail: sales@stauffireland.com
www.stauff.co.uk

Italy

STAUFF Italia s.r.l
Via Borima 21 (Frazione Borima)
23867 Suello (LC)
Tel.: +39 031 65 84 94
Fax: +39 031 65 50 05
E-Mail: sales@stauff.it
www.stauff.it

Poland

STAUFF Polska Sp. z o.o.
Miszewko 43 A
80-297 Banino
Tel.: +48 58 660 11 60
Fax: +48 58 629 79 52
E-Mail: sales@stauff.pl
www.stauff.pl

Russian Federation

STAUFF LLC
Building 1
19, Leninskaya Sloboda
Moscow, 115280
Tel.: +7 495 276 16 50
Fax: +7 495 276 16 51
E-Mail: sales@stauff.ru
www.stauff.ru

United Kingdom

STAUFF UK Ltd.
500, Carlisle Street East
Off Downgate Drive
Sheffield, S4 8BS
Tel.: +44 114 251 85 18
Fax: +44 114 251 85 19
E-Mail: sales@stauff.co.uk
www.stauff.co.uk

STAUFF UK Ltd.
Badentoy Avenue
Badentoy Industrial Estate
Portlethen, Aberdeen, AB12 4YB
Tel.: +44 1224 78 61 66
Fax: +44 1224 78 61 77
E-Mail: sales@stauffscotland.co.uk
www.stauff.co.uk

STAUFF UK Ltd.
Unit 9, Southampton Trade Park
Third Avenue, Millbrook
Southampton, SO15 0AD
Tel.: +44 2380 69 87 00
Fax: +44 2380 69 87 01
E-Mail: sales@stauffsouthampton.co.uk
www.stauff.co.uk

Further branch offices in
Engels, Volzhskiy, Magnitogorsk,
Nizhny Novgorod and St. Petersburg.

North America

Canada

STAUFF Canada Ltd.
866 Milner Avenue
Scarborough
Ontario M1B 5N7
Tel.: +1 416 282 46 08
Fax: +1 416 282 30 39
E-Mail: sales@stauffcanada.com
www.stauffcanada.com

United States

STAUFF Corporation
7 Wm. Demarest Place
Waldwick, 07463-1542
New Jersey
Tel.: +1 201 444 78 00
Fax: +1 201 444 78 52
E-Mail: sales@stauffusa.com
www.stauffusa.com

Further branch office in
Canton, Michigan.

South America

Brazil

STAUFF Brasil Ltda.
Avenida Gupê 10767
Galpão 2 - Bloco A
Barueri, São Paulo, CEP 06422-120
Tel.: +55 11 47 72 72 00
Fax: +55 11 47 72 72 10
E-Mail: stauff@stauffbrasil.com
www.stauffbrasil.com



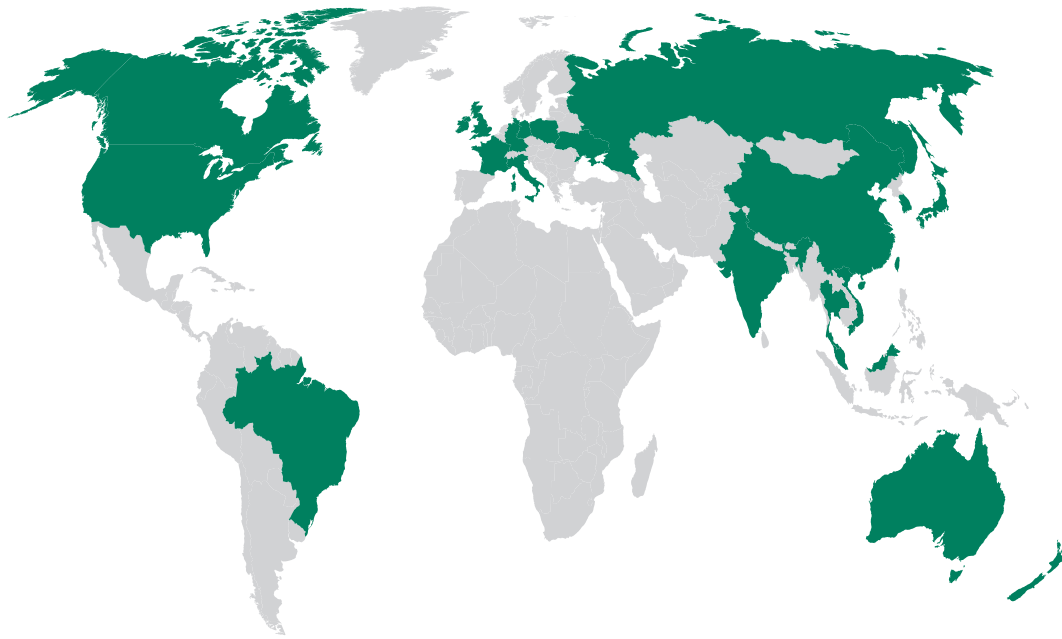

Asia

China

STAUFF CHINA

Building 1, No. 128, Die Qiao Road
Jushuo Industrial Zone, Kang Qiao
Shanghai, 201319
Tel.: +86 21 68 18 70 00
Fax: +86 21 68 18 71 36
E-Mail: info@stauff.com.cn
www.stauff.com.cn

Further branch offices in Beijing,
Changsha, Chengdu, Changchun,
Chongqing, Jinan, Harbin, Guangzhou,
Shenyang, Wuhan, Xian and Xuzhou.

India

STAUFF India Pvt. Ltd.

Gat no. 26/1 & 27, Sanghar Warehousing
Pune - Nagar Road
Lonikand - 412216
Tel.: +91 20 6731 4900
Fax: +91 20 6731 4905
E-Mail: sales@stauffindia.com
www.stauffindia.com

Korea

STAUFF Korea Ltd.

105, Hwajeonsandan 5-ro
Gangseo-gu
Busan, 46739
Tel.: +82 51 266 6666
Fax: +82 51 266 8866
E-Mail: info@stauff.co.kr
www.stauff.co.kr

Malaysia

STAUFF South East Asia Sdn Bhd

No. 8, Jalan SS13/6A
Subang Jaya Industrial Estate
47500 Subang Jaya
Tel.: +60 3 5637 78 88
Fax: +60 3 5636 78 90
E-Mail: sales@stauff.com.my
www.stauff.com.my

Thailand

STAUFF (Thailand) Co., Ltd.

10 Soi On-Nut 74/4
Pravet District
Bangkok 10250
Tel.: +66 2 721 73 23 / 24
Fax: +66 2 721 73 35
E-Mail: sales@stauff.co.th
www.stauff.co.th

Vietnam

STAUFF Vietnam Ltd.

2nd Floor, CT-IN Building
#435 Hoang Van Thu Street
Tan Binh District, Ho Chi Minh City
Tel.: +84 8 3948 10 41 / 42
Fax: +84 8 3948 10 44
E-Mail: sales@stauff.com.vn
www.stauff.com.vn

Oceania

Australia

STAUFF Corporation Pty Ltd

24-26 Doyle Avenue
Unanderra NSW 2526
Tel.: +61 2 4271 9000
Fax: +61 2 4271 8432
E-Mail: sales@stauff.com.au
www.stauff.com.au

Further branch offices in
Adelaide, Brisbane, Melbourne
and Sydney.

New Zealand

STAUFF Corporation (NZ) Ltd.

Unit D, 103 Harris Road
East Tamaki, Auckland 2013
Tel.: +64 9 271 48 12
Fax: +64 9 271 48 32
E-Mail: sales@stauff.co.nz
www.stauff.co.nz



Introduction

Fluid Level and Temperature Indicators

Tank Filler Breathers

Giant and Desiccant Air Breathers

Suction Strainers

Diffusors

Appendix



Catalogue 10

STAUFF Hydraulic Accessories

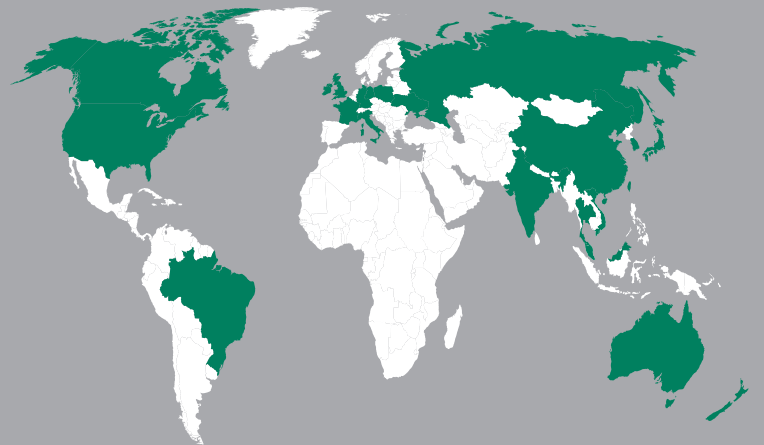

Germany

Walter Stauffenberg GmbH & Co. KG
Im Ehrenfeld 4
58791 Werdohl
Tel.: +49 2392 91 60
Fax: +49 2392 91 61 60
E-Mail: sales@stauff.com

STAUFF products and services are globally available through wholly-owned subsidiaries and a tight network of authorised distributors and representatives in all major industrial regions of the world.

You can find detailed contact information on the last two pages of this product catalogue or at

www.stauff.com