

Black Bruin



**Product Manual
BB and BBC series**

Contents

1	General Instructions.....	4
1.1	About the manual.....	4
1.2	Intended use.....	4
1.3	Warranty.....	4
1.4	Product identification.....	4
1.5	Publication date.....	5
1.6	Declaration of incorporation.....	5
2	Safety Instructions.....	6
2.1	Warning symbols.....	6
3	Motor Description.....	7
3.1	Working principle.....	7
3.2	Motor model code BB series.....	8
3.3	Motor model code BBC series.....	9
3.4	Technical data BB series.....	10
3.5	Technical data BBC series.....	12
3.6	Motor interfaces.....	14
3.6.1	Main dimensions.....	14
3.6.2	Shaft interfaces.....	16
3.6.3	Hub interfaces.....	21
3.7	Rotating direction.....	25
3.8	Freewheeling.....	26
3.8.1	Hydrostatic freewheeling.....	26
3.8.2	Mechanical freewheeling.....	27
3.9	1-speed motors.....	28
3.10	Multi-speed motors.....	29
3.11	Seal protector and grease nipples.....	31
3.12	Brakes.....	31
3.12.1	Static wet multi-disc brake for BBC and BB series motors.....	31
3.12.2	Double brake for BBC series motors.....	32
4	System Design.....	33
4.1	Motor hydraulic circuit.....	33
4.1.1	Simple connection.....	33
4.1.2	Counter pressure operation.....	33
4.1.3	Hydrostatic braking.....	34
4.1.4	Short circuit operation.....	34
4.2	Hydraulic connections.....	35
4.3	External freewheeling valve.....	37
4.4	Hydraulic fluid.....	39
4.4.1	Motors in parallel or series circuit.....	39
4.4.2	Hydraulic fluid type.....	41
4.4.3	Hydraulic fluid properties.....	41
4.4.4	Hydraulic fluid cleanliness.....	41
4.5	Operating pressures.....	41
4.5.1	Case pressure.....	41
4.5.2	Pilot pressure.....	42
4.5.3	Working line pressure.....	42

5	Motor Sizing.....	46
5.1	Load carrying capacity.....	46
5.1.1	Wheel offset.....	46
5.1.2	Allowed wheel load.....	47
5.1.3	Service life.....	48
5.2	Performance.....	50
5.2.1	Rotating speed and flow rate.....	50
5.2.2	Torque.....	51
5.2.3	Power.....	52
5.3	Performance charts.....	52
5.3.1	BB motors performance curves.....	52
5.3.2	BBC motors performance curves.....	58
5.3.3	BB motors case leakage.....	62
5.3.4	BBC motors case leakage.....	63
6	Installation Instructions.....	64
6.1	Conditions of installation and application.....	64
6.2	Mounting the motor.....	64
6.3	Flushing the hydraulic system.....	64
6.4	Hydraulic connections.....	65
6.5	Air bleeding procedure.....	65
6.6	Commissioning procedure.....	65
6.7	Tightening torques.....	66
7	Operating Instructions.....	67
7.1	Break-in period.....	67
7.2	Use.....	67
7.3	Operating temperature.....	67
7.4	Demounting the motor.....	67
8	Special Instructions.....	69
8.1	Storing the motor.....	69

1 General Instructions

1.1 About the manual

This manual contains the technical instructions for the Black Bruin BB and BBC series hydraulic motors. Take these instructions into consideration when planning the use of the product.

All information given in this manual is current and valid according to the information available at the time of publication. The manufacturer reserves the rights to implement changes without prior notice.

Please visit www.blackbruin.com for the most recent version of this manual. The product datasheets and the 3D-models are available from the manufacturer by request.

1.2 Intended use

Black Bruin BB and BBC series hydraulic motors are designed to be used as hub motors on vehicles. They can also be used in other applications that need torque for rotary movement.

1.3 Warranty

Check the package and the product for transport damage when receiving goods. The package is not meant for long term storage; protect the product appropriately.

Do not dismantle the product. The warranty is void if the product has been disassembled.

The manufacturer is not responsible for damages resulting from misinterpreted, non-compliance, incorrect, or improper use of the product that goes against the instructions given in this document.

1.4 Product identification

The product identification data can be found on the identification plate attached to the motor.



Figure 1. Identification plate of the motor.



Note:

The serial number is also stamped on the motor. All manufacturing data can be found with the serial number.

1.5 Publication date

26.04.2019 - This manual is published.

1.6 Declaration of incorporation

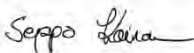
Black Bruin	DECLARATION OF INCORPORATION 1(1)
	2017-09-27
Black Bruin Inc.	
DECLARATION OF INCORPORATION (in accordance with EC Machinery Directive 2006/42/EC, Annex II B)	
Manufacturer	Black Bruin Inc.
Address	Valmetintie 9 FI-40420 Jyskä, FINLAND
Product description	Black Bruin hydraulic motor series: <ul style="list-style-type: none"> ▪ BBC ▪ BB ▪ B200 ▪ S
	We hereby declare that the product(s) specified above is intended to be incorporated into machinery or to be assembled with other machinery to constitute machinery covered by EC Machinery Directive 2006/42/EC, as amended.
	And that the following harmonised standards have been applied: <ul style="list-style-type: none"> ▪ EN ISO 4413:2010 (Hydraulic fluid power - General rules and safety requirements for systems and their components) ▪ EN ISO 12100:2010 (Safety of machinery – General principles for design – Risk assessment and risk reduction)
	And furthermore declares that the product(s) covered by this declaration must not be put into service until the final machinery into which it is to be incorporated has been declared in conformity with the provisions of EC Machinery Directive 2006/42/EC.
	The product(s) must be applied and installed in accordance with all the technical documents applicable to the product(s).
	This document supersedes all previous releases to this subject.
Place and date	Jyväskylä, 2017-09-27
	On behalf of Black Bruin Inc.
	
Name	Seppo Koironen
Title	Technical Director
<hr/> <small>BLACK BRUIN INC. P.O. Box 633, FI-40101 JYVÄSKYLÄ, FINLAND +358 20 755 0755 info@blackbruin.com www.blackbruin.com</small>	

2 Safety Instructions

The following instructions apply to all procedures associated with the motor. Read these instructions carefully and follow them closely.

- Use necessary personal protective equipment when working with the motor.
- Support the motor properly. Make sure the motor cannot fall over or turn around by accident.
- Use only appropriate equipment and attachments for lifting and transferring the motor.
- Do not use magnetic lifting devices.
- Always use the lifting equipment properly and check the load-bearing capacity.
- Prevent unintended use of the motor during installation and maintenance procedures by preventing pressurization of the hydraulic lines.
- The operating temperature of the motor may be over 60 °C (140 °F), which is hot enough to cause severe burns. Beware of hot hydraulic fluid when disconnecting the hydraulic connections.

2.1 Warning symbols

The following symbols are used in this manual:



Note:

Useful information.



Danger:

Danger of death or injury.



Attention:

May cause damage to the product.

3 Motor Description

3.1 Working principle

BB and BBC series motors are rotary-housing. This means the motor shaft and the cylinder block remain in place while the motor is running.

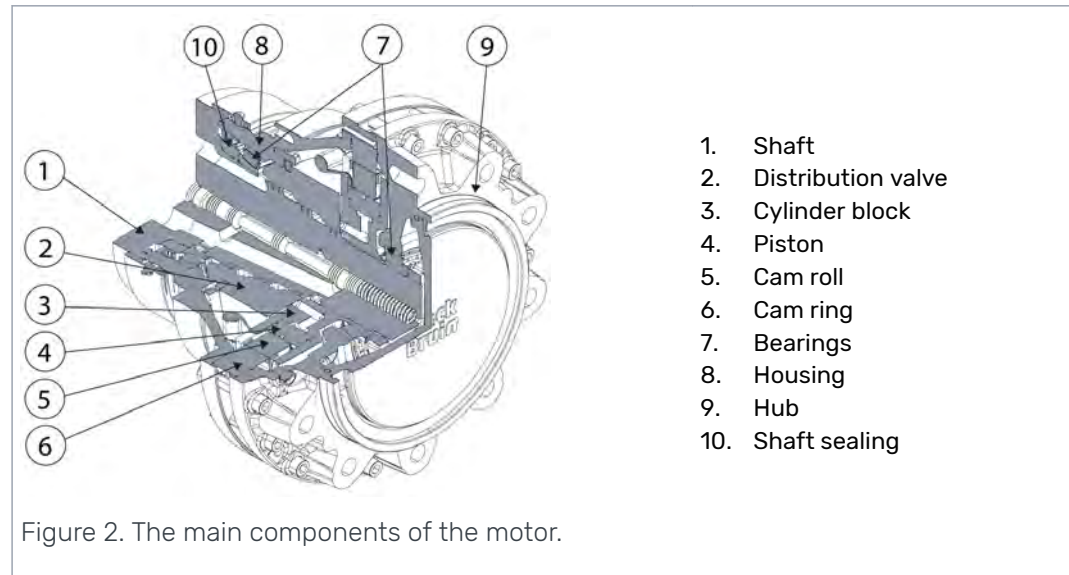

The rotation of the motor is achieved by feeding pressurized hydraulic fluid through the motor shaft to the distribution valve. The distribution valve directs the flow to the pistons which are on a power stroke. Pressure pushes the pistons and cam rolls outwards against the cam ring on the housing. The waveform of the cam ring transforms the force into torque. When the pistons reach the end of the power stroke, the distribution valve closes the flow to the pistons and switches the pistons to a return stroke. The cam ring pushes the pistons back into the cylinder block preparing them for the next outward power stroke.

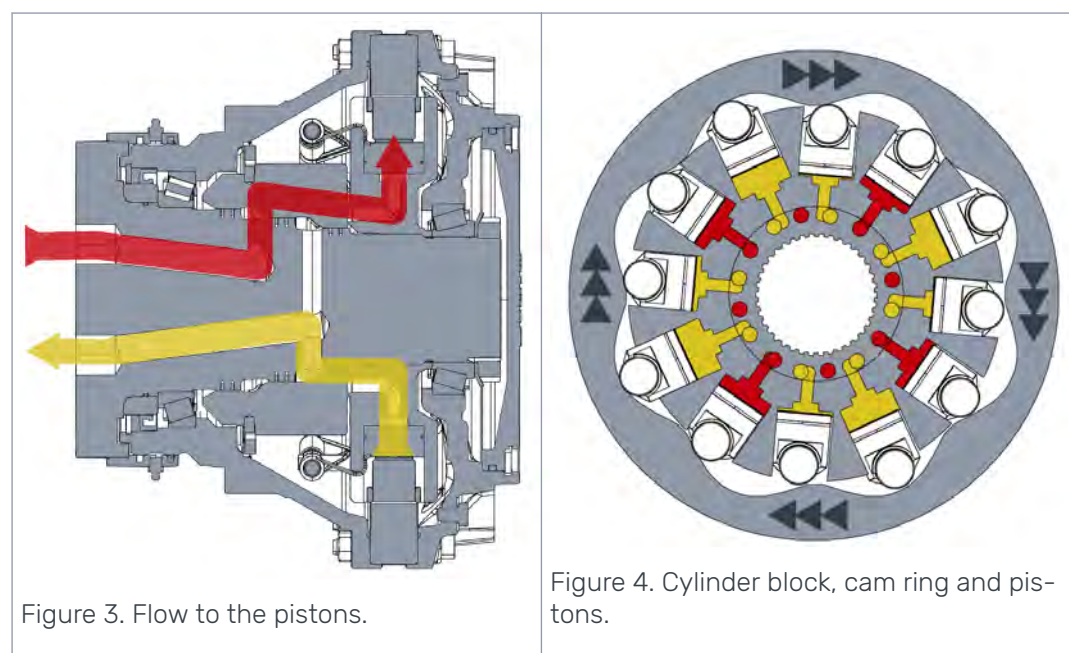

3.2 Motor model code BB series

BB SERIES MODEL CODE	40DVVVYW40
Hydraulic motors with parking brake	

40	40DVVVYW40
BB series standard code	

D: Motor frame size	40DVVVYW40	BB 4	BB 5	BB 6	BB 7
BB 4: 630-800 ccm	<u>4</u>	•			
BB 5: 1000-1600 ccm	<u>5</u>		•		
BB 6: 2000-3150 ccm	<u>6</u>			•	
BB 7: 4000-6300 ccm	<u>7</u>				•

VVV: Motor displacement	40DVVVYW40	BB 4	BB 5	BB 6	BB 7
BB 4 displacements	<u>063</u> : 630 ccm/rev	•			
	<u>080</u> : 800 ccm/rev	•			
BB 5 displacements	<u>100</u> : 1000 ccm/rev		•		
	<u>125</u> : 1250 cmm/rev		•		
	<u>160</u> : 1600 ccm/rev		•		
BB 6 displacements	<u>200</u> : 2000 ccm/rev			•	
	<u>250</u> : 2500 ccm/rev			•	
	<u>315</u> : 3150 ccm/rev			•	
BB 7 displacements	<u>400</u> : 4000 ccm/rev				•
	<u>500</u> : 5000 ccm/rev				•
	<u>630</u> : 6300 ccm/rev				•

Y: Freewheeling	40DVVVYW40	BB 4	BB 5	BB 6	BB 7
Hydraulic freewheeling	<u>1</u>	•	•	•	•
Mechanical freewheeling	<u>2</u>	•	•	•	•

W: Multi-speed option	40DVVVYW40	BB 4	BB 5	BB 6	BB 7
Fixed displacement	<u>1</u>	•	•	•	•
2-speed	<u>2</u> : CW rotation	•	•	•	•
2-speed	<u>3</u> : CCW rotation	•	•	•	•

Code example	4051602140
40DVVVYW40	
40 =	The motor model series is "BB"
D =	The frame of the motor is "BB 5"
VVV =	The displacement of the motor is 1600 ccm
Y =	The motor with mechanical freewheeling
W =	The motor with fixed displacement

Code example	<u>4051602140</u>
4 =	The motor with a wet multi-disc parking brake
0 =	The motor is a standard motor

3.3 Motor model code BBC series

BBC SERIES MODEL CODE	<u>CDVWE1Y0AA</u>
Hydraulic motors	

C	<u>CDVWE1Y0AA</u>
BBC series standard code	

D: Motor frame size	<u>CDVWE1Y0AA</u>	BBC 02	BBC 03	BBC 05
BBC 02: 705-1018 ccm	<u>2</u>	•		
BBC 03: 909-1313 ccm	<u>3</u>		•	
BBC 05: 1572-2271 ccm	<u>5</u>			•

V: Motor displacement	<u>CDVWE1Y0AA</u>	BBC 02	BBC 03	BBC 05
BBC 02 displacements	<u>1</u> : 705 ccm/rev	•		
	<u>3</u> : 862 ccm/rev	•		
	<u>5</u> : 1018 ccm/rev	•		
BBC 03 displacements	<u>1</u> : 909 ccm/rev		•	
	<u>3</u> : 1111 ccm/rev		•	
	<u>5</u> : 1313 ccm/rev		•	
BBC 05 displacements	<u>1</u> : 1572 ccm/rev			•
	<u>3</u> : 1922 ccm/rev			•
	<u>5</u> : 2271 ccm/rev			•

W: Multi-speed option	<u>CDVWE1Y0AA</u>	BBC 02	BBC 03	BBC 05
1-speed	<u>1</u> : Fixed displacement	•	•	•
2-speed	<u>2</u> : 100 / 50% displacement	•	•	•
4-speed	<u>7</u> : 100 / 75 / 50 / 25 % displacement			•

E: Brake option	<u>CDVWE1Y0AA</u>	BBC 02	BBC 03	BBC 05
Without brake	<u>0</u>	•	•	•
Static wet multi-disc brake	<u>1</u>	•	•	•
Dynamic brake + static wet multi-disc parking brake	<u>C</u>	•	•	

Y: Freewheeling	<u>CDVWE1Y0AA</u>	BBC 02	BBC 03	BBC 05
Hydraulic freewheeling	<u>0</u>	•	•	•
Mechanical freewheeling	<u>1</u>	•	•	•

Motor Description

Code example	C2321110AA
	CDVWE1Y0AA
C =	The motor model series is "BBC"
D =	The frame of the motor is "BBC 02"
V =	The displacement of the motor is 862 ccm
W =	The motor with a 2-speed valve (862 ccm - 1/1 displ., 431 ccm - 1/2 displ.)
E =	The motor with a wet multi-disc parking brake
1 =	The motor with a case flushing line
Y =	The motor with mechanical freewheeling
0 =	N/A
AA =	The motor is a standard motor

3.4 Technical data BB series

TECHNICAL DATA	BB 4		BB 5			
Displacement [ccm]	630	800	1000	1250	1600	
Maximum torque [Nm]	peak torque	3300	4190	5240	6540	8380
	intermittent	2825	3590	4490	5610	7180
Max. operating power [kW]	at full displacement	35		50		
	at half displacement	21		30		
Max. rotating speed [rpm]	at full displacement	240	185	200	160	125
	at half displacement	360	275	300	240	185
	at freewheeling	600			500	
Min. rotating speed [rpm]	2			2		
Max. working pressure [bar]	peak pressure	350		350		
	intermittent ¹⁾	300		300		
Max. case pressure [bar]	average	2		2		
	intermittent ¹⁾	10		10		
Pilot pressure for internal valve [bar]	valve released	0-2		0-2		
	valve engaged	15-30 ²⁾		15-30 ²⁾		
Max. flow rate [l/min]	at full displacement	150		200		
	at half displacement	113		150		
Spring operated wet multi-disc brake (parking brake)	brake torque (min.) [Nm]	3700		8000		
	³⁾					

TECHNICAL DATA	BB 4	BB 5
releasing pressure [bar]	70	86
brake pressure (max.) [bar]	300	300
needed oil volume [ccm]	30	40
Weight [kg]	66	114

TECHNICAL DATA	BB 6			BB 7		
Displacement [ccm]	2000	2500	3150	4000	5000	6300
Maximum torque [Nm]						
peak torque	13440	16810	21170	26890	33530	42300
intermittent	11950	14940	18820	23900	29800	37600
Max. operating power [kW]						
at full displacement	90			130		
at half displacement	54			80		
Max. rotating speed [rpm]						
at full displacement	175	140	110	125	100	80
at half displacement	220	180	145	160	130	105
at freewheeling	400			350		
Min. rotating speed [rpm]	2			2		
Max. working pressure [bar]						
peak pressure	450			450		
intermittent ¹⁾	400			400		
Max. case pressure [bar]						
average	2			2		
intermittent ¹⁾	10			10		
Pilot pressure for internal valve [bar]						
valve released	0-2			0-2		
valve engaged	15-30 ²⁾			15-30 ²⁾		
Max. flow rate [l/min]						
at full displacement	350			500		
at half displacement	225			325		
Spring operated wet multi-disc brake (parking brake)						
brake torque (min.) [Nm] ³⁾	20000			40000		
releasing pressure [bar]	52			63		
brake pressure (max.) [bar]	250			250		
needed oil volume [ccm]	110			140		
Weight [kg]	189			365		

¹⁾ Intermittent operation: permissible values for maximum of 10% of every minute.

²⁾ If pilot pressure over 30 bar is used, the pilot line should be throttled.

³⁾ Brake torque for new brake.

3.5 Technical data BBC series

TECHNICAL DATA	BBC 02			BBC 03			
Displacement [ccm]	705	862	1018	909	1111	1313	
Maximum torque [Nm]	peak torque	4645	5680	5965	5990	7320	7690
	intermittent	4130	5050	5220	5325	6510	6730
Max. operating power [kW]	at full displacement	42			50		
	at half displacement	28			33		
Max. rotating speed [rpm]	at full displacement	223	182	154	206	169	143
	at half displacement	318	260	220	290	238	201
	at freewheeling	450			425		
Min. rotating speed [rpm]	2			2			
Max. working pressure [bar]	peak pressure	450	450	400	450	450	400
	intermittent ¹⁾	400	400	350	400	400	350
Max. case pressure [bar]	average	2			2		
	intermittent ¹⁾	10			10		
Pilot pressure for internal valve [bar]	valve released	0-2			0-2		
	valve engaged	15-30 ²⁾			15-30 ²⁾		
Max. flow rate [l/min]	at full displacement	157			187		
	at half displacement	112			132		
Spring operated wet multi-disc brake (parking brake)	brake torque (min.) [Nm] ³⁾	6560			8470		
	releasing pressure [bar]	16			16		
	brake pressure (max.) [bar]	30			30		
	needed oil volume [ccm]	120			150		
Dynamic multi-disc brake (service brake)	brake torque (min.) [Nm] ³⁾	7800			10700		
	brake pressure (max.) [bar]	60			60		
Weight [kg]	without brake			62			80

TECHNICAL DATA	BBC 02	BBC 03
with parking brake	72	96
with double brake	122	148

TECHNICAL DATA	BBC 05		
Displacement [ccm]	1572	1922	2271
Maximum torque [Nm]			
peak torque	10360	12670	13305
intermittent	9210	11260	11640
Max. operating power [kW]			
at full displacement	72		
at 3/4 displacement	60		
at half displacement	48		
at 1/4 displacement	32		
Max. rotating speed [rpm]			
at full displacement	172	141	119
at 3/4 displacement	205	168	142
at half displacement	244	200	169
at 1/4 displacement	326	266	226
at freewheeling	400		
Min. rotating speed [rpm]	2		
Max. working pressure [bar]			
peak pressure	450	450	400
intermittent ¹⁾	400	400	350
Max. case pressure [bar]			
average	2		
intermittent ¹⁾	10		
Pilot pressure for internal valve [bar]			
valve released	0-2		
valve engaged	15-30 ²⁾		
Max. flow rate [l/min]			
at full displacement	270		
at 3/4 disp	242		
at half displacement	192		
at 1/4 disp	128		
Spring operated wet multi-disc brake (parking brake)			
brake torque (min.) [Nm] ³⁾	20600		
releasing pressure [bar]	16		
brake pressure (max.) [bar]	30		
needed oil volume [ccm]	260		

Motor Description

TECHNICAL DATA		BBC 05
Weight [kg]	without brake	138
	with parking brake	158

- 1) Intermittent operation: permissible values for maximum of 10% of every minute.
- 2) If pilot pressure over 30 bar is used, the pilot line should be throttled.
- 3) Brake torque for new brake.

3.6 Motor interfaces

3.6.1 Main dimensions

BB series motors with static multi-disc brake

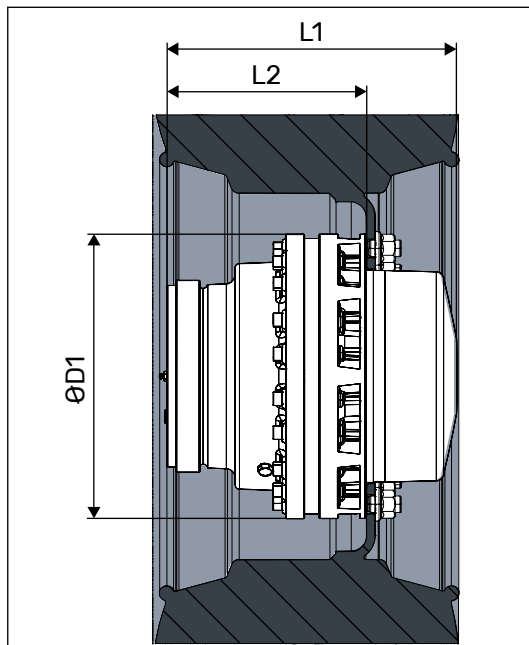

Figure 5. Main dimensions of the motor.

MAIN DIMENSIONS		BB 4	BB 5	BB 6	BB 7
Motor					
L1	[mm]	420	469	480	550
L2	[mm]	265	282	320	382
D1	[mm]	278	342	408	512

BBC series motors without brake

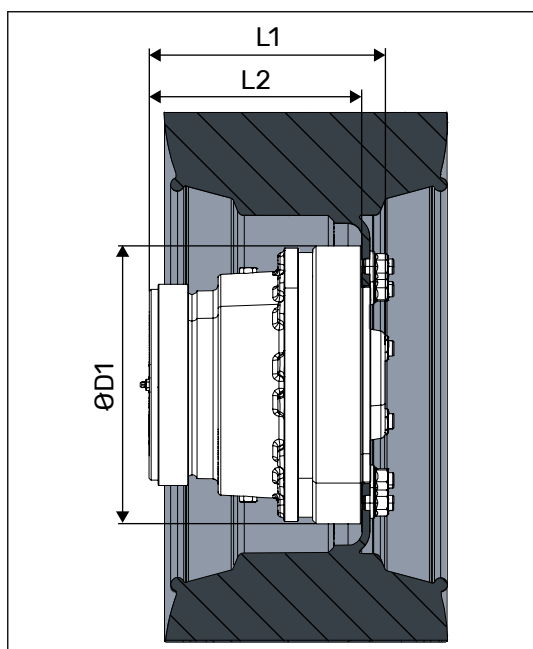

Figure 6. Main dimensions of the motor.

MAIN DIMENSIONS		BBC 02	BBC 03	BBC 05
Motor				
L1	[mm]	254	268	298
L2	[mm]	233	241	259
D1	[mm]	282	315	376

BBC series motors with static multi-disc brake

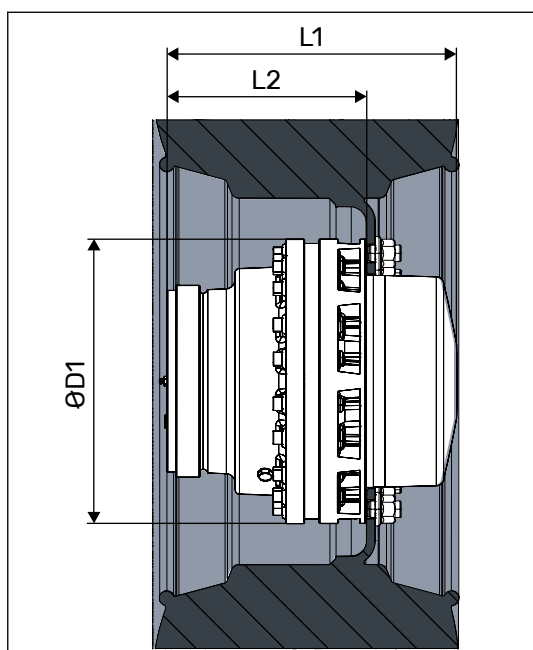

Figure 7. Main dimensions of the motor.

Motor Description

MAIN DIMENSIONS		BBC 02	BBC 03	BBC 05
Motor				
L1	[mm]	322	331	383
L2	[mm]	236	241	263
D1	[mm]	282	315	376

BBC series motors with double brake

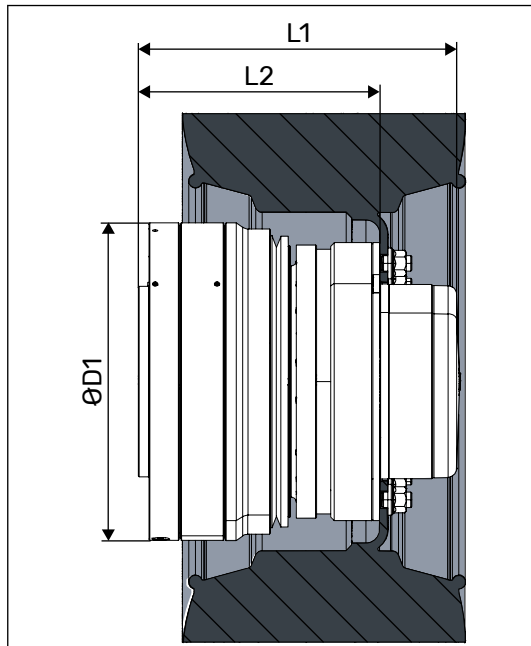

Figure 8. Main dimensions of the motor.

MAIN DIMENSIONS		BBC 02	BBC 03
Motor			
L1	[mm]	353	364
L2	[mm]	267	274
D1	[mm]	360	360

3.6.2 Shaft interfaces

The motor is attached to the body of the vehicle or device from the shaft flange. The hydraulic connections of the motor are located on the plane surface of the shaft flange.

BB series motors with static multi-disc brake

Figure 9. Dimensions of the shaft interface.

INTERFACE DIMENSIONS		BB 4	BB 5	BB 6	BB 7
Shaft interface					
D1	[mm]	140	175	200	260
	pattern	6x60°	8x45°	12x30°	16x22,5°
	size	M16x2,0	M16x2,0	M20x1,5	M20x1,5
	strength class 1)	12,9	12,9	12,9	12,9
	tightening torque 2) [Nm]	330	330	650	650
D2	min. 3) [mm]	114	150	170	220
D3	min. 4) [mm]	165	200	240	300
R1	max. [mm]	1	1	1	1
C1	[mm]	4-10	4-10	4-10	4-10

1) Strength class as in ISO898-1. If using lower strength class, check interface load capacity and tightening torque.

2) Declared values are for reference only. Always use application specific tightening torques when given.

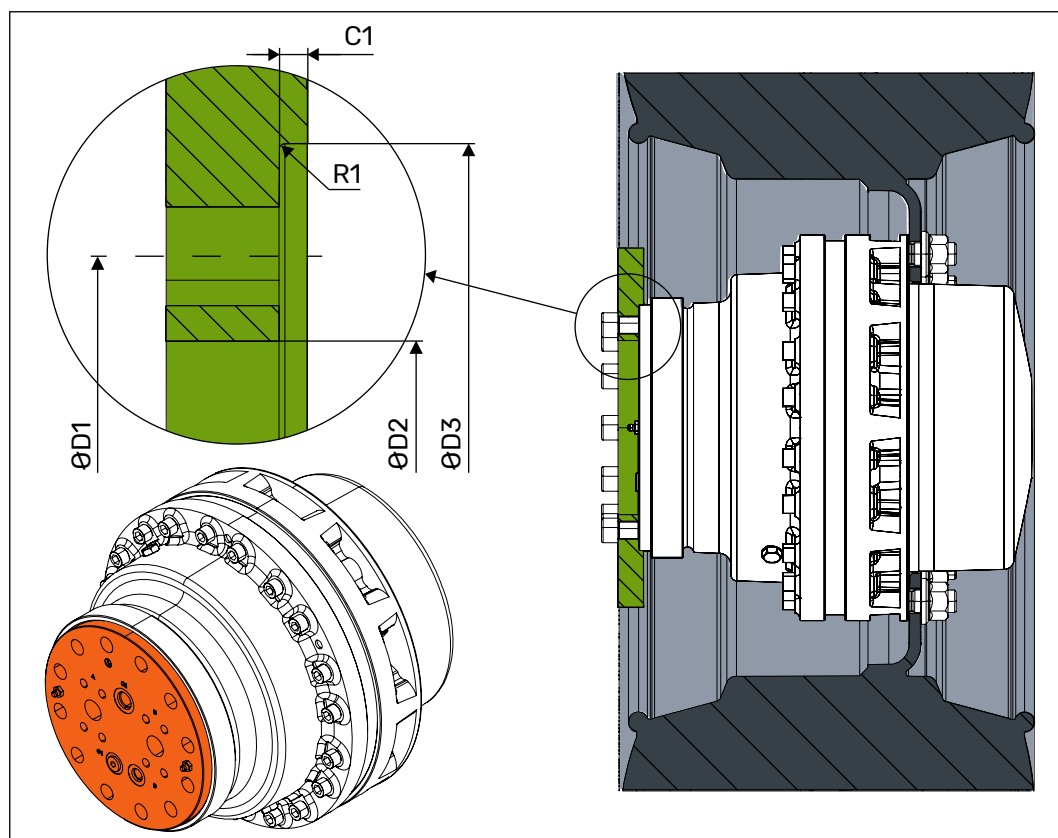
3) Free space for hydraulic connections.

4) Recommended feature to support and center the motor.

BBC series motors without brake

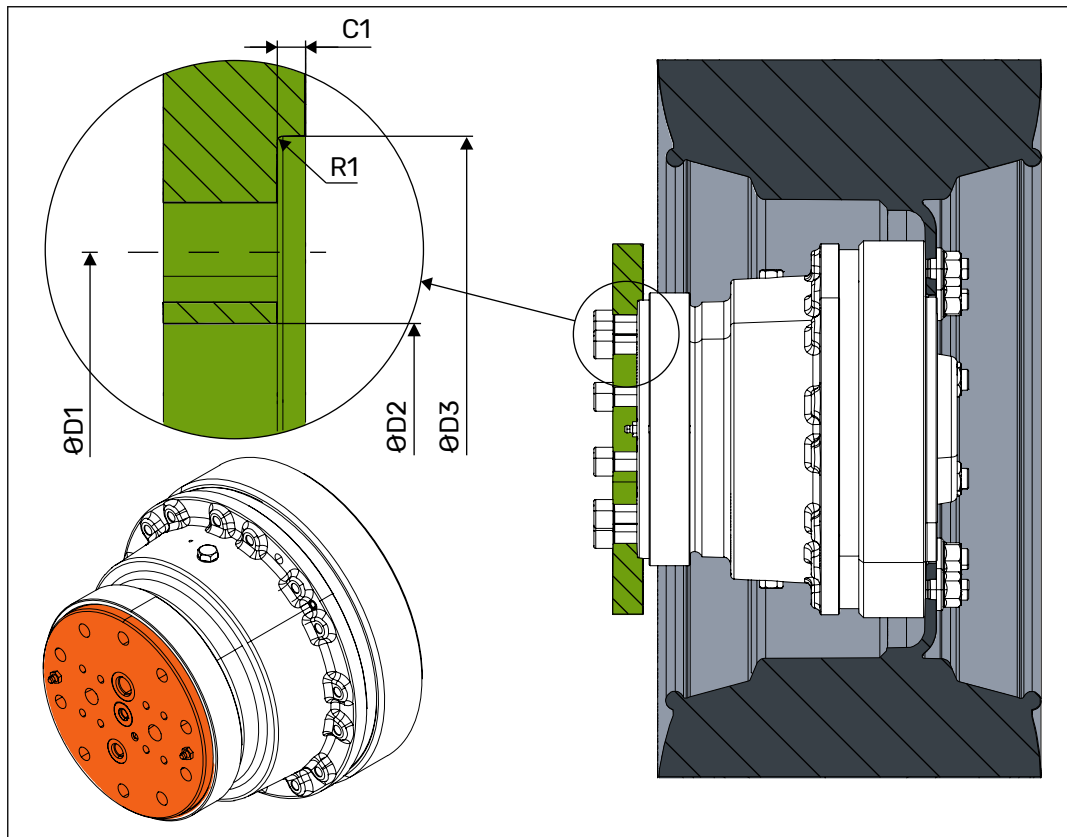

Figure 10. Dimensions of the shaft interface.

INTERFACE DIMENSIONS		BBC 02	BBC 03	BBC 05
Shaft interface				
D1	[mm]	160	175	200
	pattern	8x45°	10x36°	12x30°
	size	M16x2,0	M16x2,0	M20x1,5
	strength class 1)	12,9	12,9	12,9
	tightening torque 2) [Nm]	330	330	650
D2	min. 3) [mm]	135	150	166
D3	min. 4) [mm]	200	216	240
	R1 max. [mm]	1	1	1
	C1 [mm]	4-10	4-10	4-10

1) Strength class as in ISO898-1. If using lower strength class, check interface load capacity and tightening torque.

2) Declared values are for reference only. Always use application specific tightening torques when given.

3) Free space for hydraulic connections.

4) Recommended feature to support and center the motor.

BBC series motors with static multi-disc brake

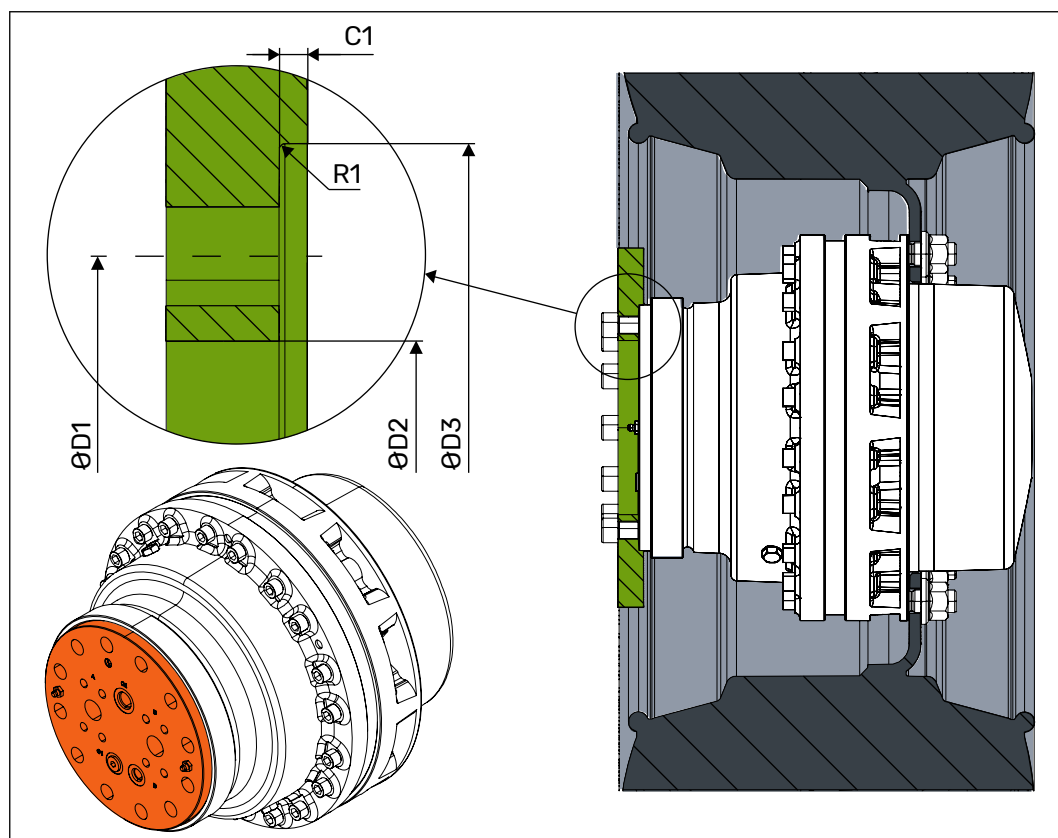

Figure 11. Dimensions of the shaft interface.

INTERFACE DIMENSIONS		BBC 02	BBC 03	BBC 05
Shaft interface				
D1	[mm]	160	175	200
	pattern	8x45°	10x36°	12x30°
	size	M16x2,0	M16x2,0	M20x1,5
	strength class 1)	12,9	12,9	12,9
	tightening torque 2) [Nm]	330	330	650
D2	min. 3) [mm]	135	150	166
D3	min. 4) [mm]	200	216	240
	R1 max. [mm]	1	1	1
	C1 [mm]	4-10	4-10	4-10

1) Strength class as in ISO898-1. If using lower strength class, check interface load capacity and tightening torque.

2) Declared values are for reference only. Always use application specific tightening torques when given.

3) Free space for hydraulic connections.

4) Recommended feature to support and center the motor.

BBC series motors with double brake

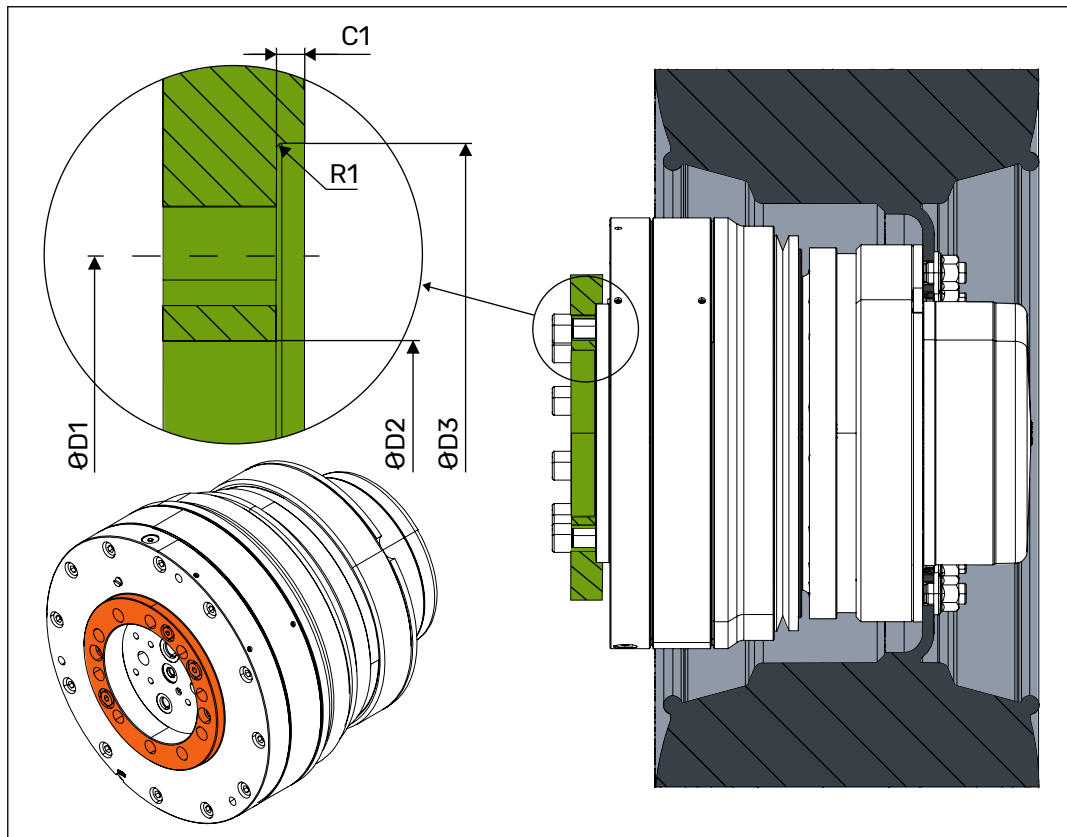

Figure 12. Dimensions of the shaft interface.

INTERFACE DIMENSIONS		BBC 02	BBC 03
Shaft interface			
D1	[mm]	160	175
	pattern	8x45°	10x36°
	size	M16x2,0	M16x2,0
	strength class 1)	12,9	12,9
	tightening torque 2) [Nm]	330	330
D2	min. 3) [mm]	135	150
D3	min. 4) [mm]	200	216
	R1 max. [mm]	1	1
	C1 [mm]	4-10	4-10

1) Strength class as in ISO898-1. If using lower strength class, check interface load capacity and tightening torque.

2) Declared values are for reference only. Always use application specific tightening torques when given.

3) Free space for hydraulic connections.

4) Recommended feature to support and center the motor.

3.6.3

Hub interfaces



Note:

The attachment screws are not included in the motor delivery. Ensure correct dimensioning and availability of the hub screws.

There are multiple different type of fastening screws for hub interface. Select the hub screws according to the wheel rim design.

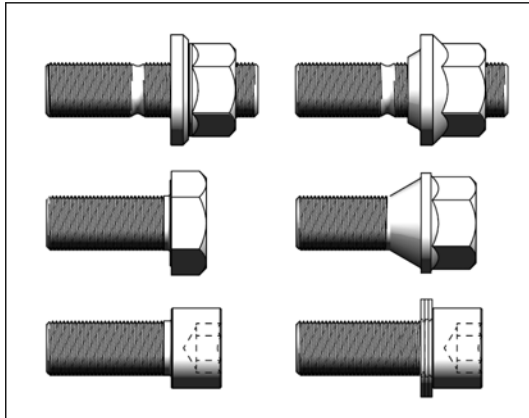

Figure 13. Hub fastening screw variants.

BB series motors with static multi-disc brake

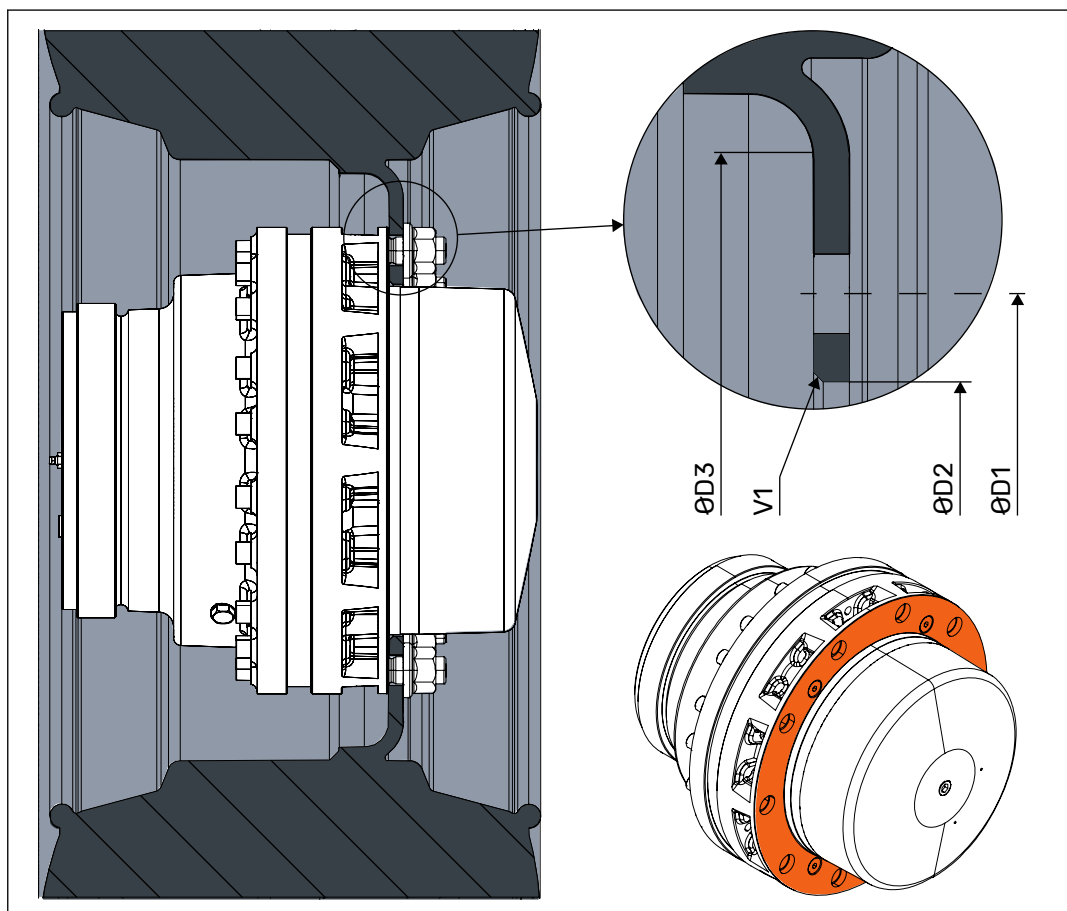

Figure 14. Dimensions of the hub interface.

INTERFACE DIMENSIONS		BB 4	BB 5	BB 6	BB 7
Hub interface					
D1	[mm]	205	275	335	425
	pattern	6x60°	8x45°	10x36°	12x30°
	size	M18x1,5	M20x1,5	M22x1,5	M22x1,5
	strength class ¹⁾	10,9	10,9	10,9	10,9
	tightening torque ²⁾ [Nm]	383	540	728	728
D2	min. [mm]	161	221	281	371
V1	min. [mm]	1x45°	1x45°	1x45°	1x45°
D3	min. [mm]	278	342	408	512

¹⁾ Strength class as in ISO898-1. If using lower strength class, check interface load capacity and tightening torque.

²⁾ Declared values are for reference only. Always use application specific tightening torques when given.

The wheel rim or the rotatable device is attached to the motor hub.

BBC series motors without brake

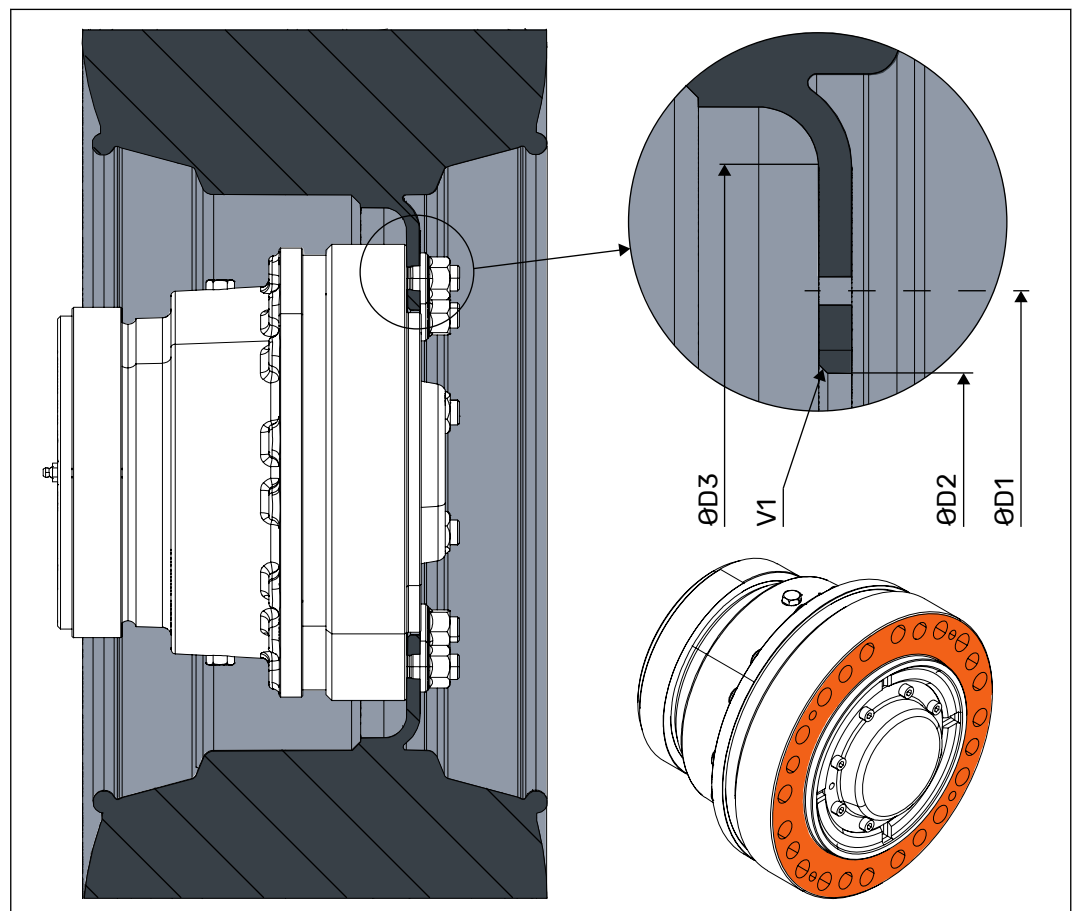

Figure 15. Dimensions of the hub interface.

INTERFACE DIMENSIONS		BBC 02	BBC 03	BBC 05
Hub interface				
D1	[mm]	225	275	335
	pattern	5x72°	8x45°	10x36°
	size	M22x1,5	M20x1,5	M22x1,5
	strength class ¹⁾	10,9	10,9	10,9
	tightening torque ²⁾ [Nm]	728	540	728
D2	min. [mm]	176	221	281
V1	min. [mm]	1x45°	1x45°	1x45°
D3	min. [mm]	282	315	376

¹⁾ Strength class as in ISO898-1. If using lower strength class, check interface load capacity and tightening torque.

²⁾ Declared values are for reference only. Always use application specific tightening torques when given.

The wheel rim or the rotatable device is attached to the motor hub.

BBC series motors with static multi-disc brake

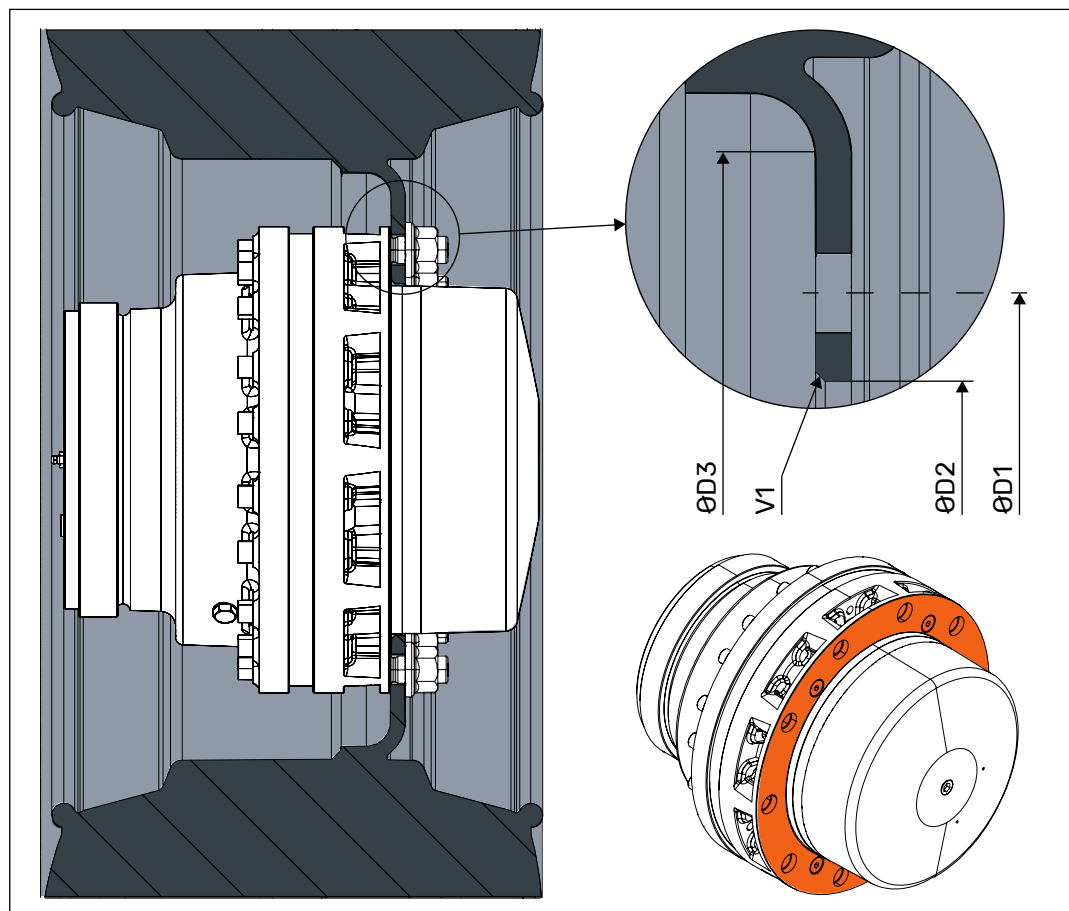

Figure 16. Dimensions of the hub interface.

INTERFACE DIMENSIONS		BBC 02	BBC 03	BBC 05
Hub interface				
D1	[mm]	225	275	335
	pattern	5x72°	8x45°	10x36°
	size	M22x1,5	M20x1,5	M22x1,5
	strength class ¹⁾	10,9	10,9	10,9
	tightening torque ²⁾ [Nm]	728	540	728
D2	min. [mm]	176	221	281
V1	min. [mm]	1x45°	1x45°	1x45°
D3	min. [mm]	282	315	376

¹⁾ Strength class as in ISO898-1. If using lower strength class, check interface load capacity and tightening torque.

²⁾ Declared values are for reference only. Always use application specific tightening torques when given.

The wheel rim or the rotatable device is attached to the motor hub.

BBC series motors with double brake

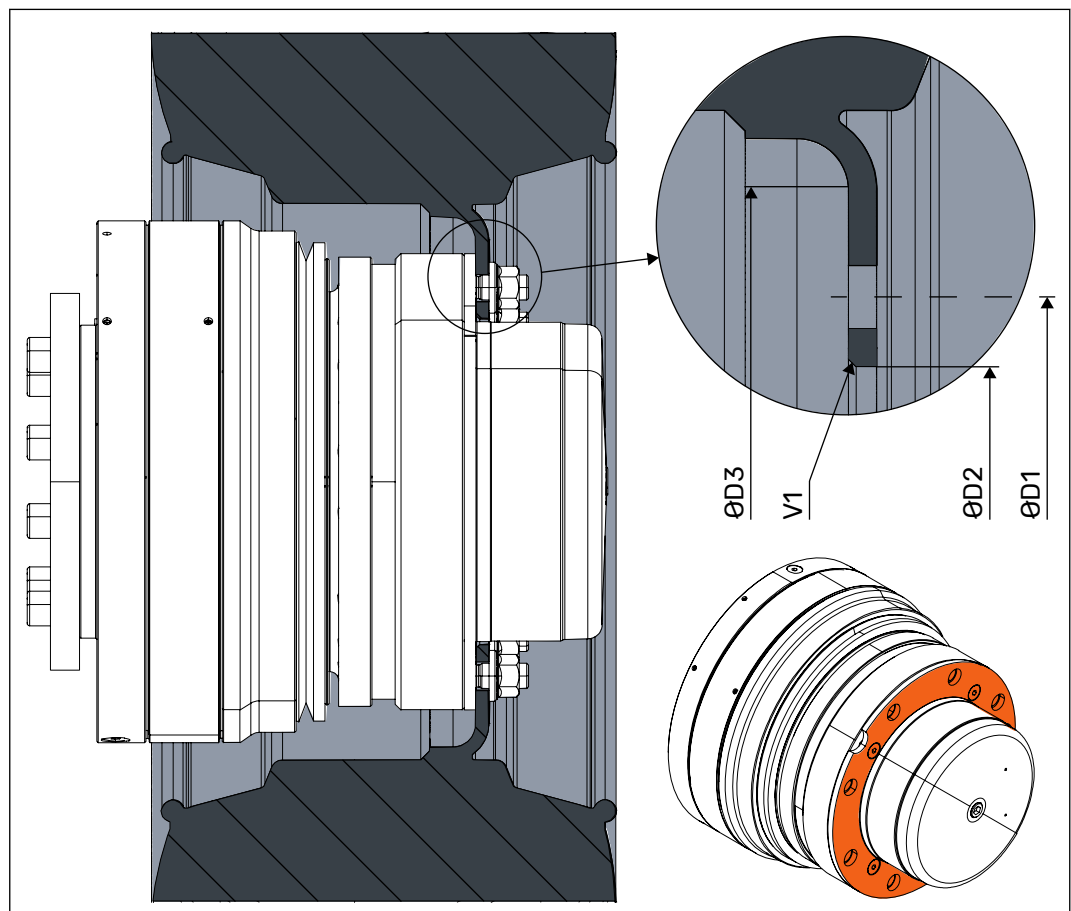

Figure 17. Dimensions of the hub interface.

INTERFACE DIMENSIONS		BBC 02	BBC 03
Hub interface			
D1	[mm]	225	275
	pattern	5x72°	8x45°
	size	M22x1,5	M20x1,5
	strength class ¹⁾	10,9	10,9
	tightening torque ²⁾ [Nm]	728	540
D2	min. [mm]	176	221
V1	min. [mm]	1x45°	1x45°
D3	min. [mm]	282	315

¹⁾ Strength class as in ISO898-1. If using lower strength class, check interface load capacity and tightening torque.

²⁾ Declared values are for reference only. Always use application specific tightening torques when given.

The wheel rim or the rotatable device is attached to the motor hub.

3.7 Rotating direction

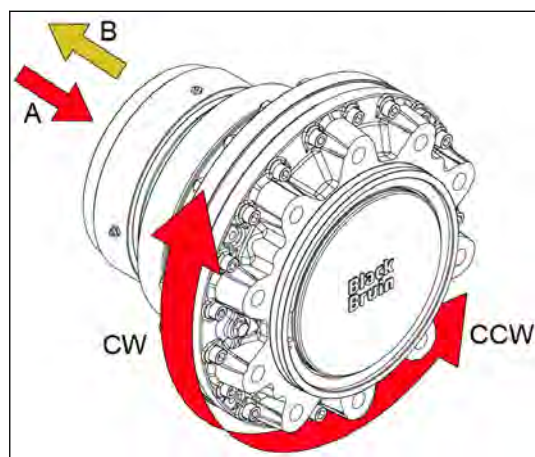

Figure 18. Rotating direction of the motor.

The rotating direction of the motor is defined as the rotating direction of the housing viewed from the hub to the shaft.

The rotating direction of the BB motor and the flow direction in the working lines is given in the table below.

Table 1: Rotating direction and flow direction of BB motors.

ROTATING DIRECTION	flow direction	
	A → B	B → A
40DVVVY140	CW	CCW
40DVVVY240	CW	CCW
40DVVVY340	CCW	CW

Preferred operating direction of BB motors

The preferred operating direction applies to BB motors with 2-speed valve.

The preferred operating direction is the rotating direction of the motor when the flow direction is from port A to B.

- **2** = CW motor (For the right side of a vehicle.)
- **3** = CCW motor (For the left side of a vehicle.)

The rotating direction of the BBC motor and the flow direction in the working lines is given in the table below.

Table 2: Rotating direction and flow direction of BBC motors.

ROTATING DIRECTION	flow direction	
	A → B	B → A
No preferred rotating direction	CW	CCW

3.8 Freewheeling

Hydrostatic freewheeling and mechanical freewheeling are options for BB and BBC series motors.

Black Bruin motors can be freewheeled without energy loss or overheating problems (stationary cylinder block - no centrifugal forces), even at high speeds. The motors can be re-engaged or disengaged during movement.

3.8.1 Hydrostatic freewheeling

Hydrostatic freewheeling requires a drain line check valve with 0.5 bar (8 psi) opening pressure and active feed between the check valve and the drain port of the motor.

A check valve in the drain line regulates the pressure in the case. To limit the pressure spikes in the case, the drain line and its check valve have to be sized to correspond with the maximum flow rate at the time of engagement.

In order to create the freewheeling pressure into the case, fluid must be supplied to case drain line C (all BB motors without flush port C1) between the motor and the check valve.

Hydrostatic freewheeling of a multispeed BBC motor

In a multispeed (2- and 4-speed) BBC motor without freewheeling springs, the freewheeling pressure is supplied to the motor case through case flushing line C1. Multispeed BBC motor has an in-built check valve and thus no external check valve in case drain line is required.

The freewheeling valve should be positioned as close to the motor as possible to ensure smooth and rapid mode change.

3.8.2 Mechanical freewheeling

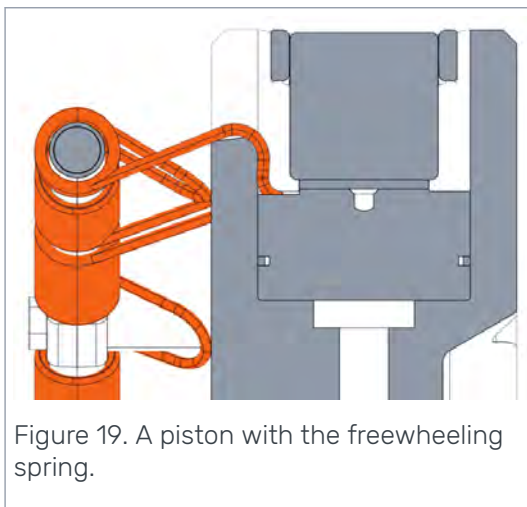

The motors can be equipped with mechanical freewheeling springs, which enable the motor disengagement. When there is no pressure in the working lines of the motor, the springs push the pistons down into the cylinders and hold them there. When disengaged the motor may be used without active fluid supply from the hydraulic system.

In systems using mechanical freewheeling, the drain line should be connected directly to the reservoir to ensure the lowest possible case pressure.

To ensure there is no pressure differential between the work lines A and B (acting under the pistons) and case drain line C (over the pistons), the three (3) lines are to be connected together in freewheel mode.

The external freewheeling valve should be positioned as close to the motor as possible to ensure smooth and rapid mode change.

USING THE FREEWHEELING

When the motor is depressurized and not rotating, the motor will disengage automatically. The motor disengagement during motion is done with a freewheeling valve.

The freewheeling valve can be a separate external valve, which connects the working lines (A and B) and the case drain line (C) together. The purpose of the valve is to remove pressure difference over the motor pistons. This allows the pistons to retract with aid of mechanical springs.

- **DISENGAGING THE MOTOR**

Open the freewheeling valve and depressurize the motor with the directional control valve to disengage the motor.

- **ENGAGING THE MOTOR**

Close the freewheeling valve and pressurize the motor with the directional control valve to engage the motor.

The directional control valve and the freewheeling valve are usually activated simultaneously.



Attention:

Any pressure in the working lines (A and B) during the freewheeling pushes the pistons out of the freewheeling position. This causes clattering noise when the pistons connect to the cam ring.

Constant clattering of the pistons may cause premature wear or failure of the motor.



Note:

Another use of the freewheeling is a more extensive speed range for vehicles having several hydraulic motors. Hydraulic system capacity may be divided between fewer motors, when some of the motors are disengaged.

ROTATING SPEED

The rotating speed of the motor should be taken into account when implementing freewheeling.

- FREEWHEELING SPEED

The freewheeling speed is the highest permissible rotating speed of the motor during freewheeling.

The permissible freewheeling speeds can be found on the technical data (see [Technical data BB series](#) on page 10 and [Technical data BBC series](#) on page 12).

DISENGAGING DELAY

While the pistons are retracting, there is a momentary flow of hydraulic fluid from the working lines to the casing of the motor. This causes always a small delay when disengaging the motor. Normal delay is about 1 - 2 seconds.

To minimize the disengaging delay, the hydraulic fluid should have as open channel as possible:

- The external freewheeling valve should be positioned as close to the motor as possible.
- All components and lines, which connect the working lines to the case drain line, should be sized for highest feasible flow rate.



Attention:

Without a freewheeling valve, the delay is considerably longer as the fluid must seep through the motor. Disengaging the motor during motion without a freewheeling valve may cause premature wear or failure of the motor.

3.9

1-speed motors

BB motors	BBC motors
40DVVVY140	CDV1E1Y0AA

Displacement control selection 1-speed means the motor has a fixed displacement. These motors are known as 1-speed motors and are always in full displacement during operation.

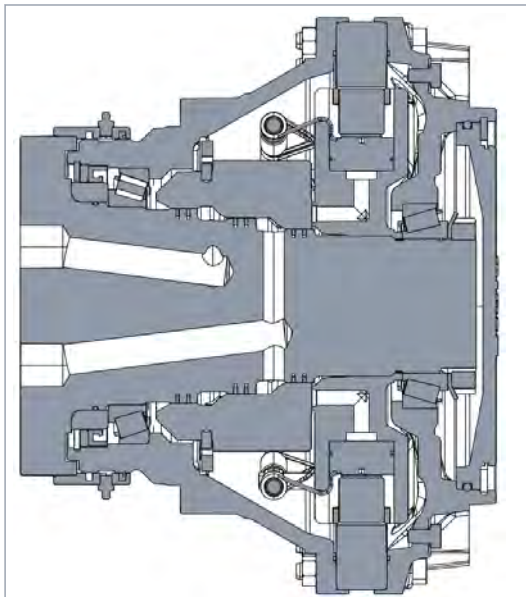

Figure 20. 1-speed motor.

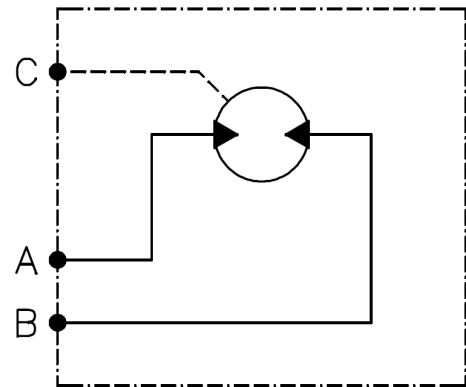

Figure 21. Hydraulic circuit, 1-speed motor.

3.10 Multi-speed motors

BB motors	BBC motors
40DVVVY ² 40	CDV ² E1Y0AA
40DVVVY ³ 40	C5V ⁷ E1Y0AA

2-speed BB motors have preferred rotational direction at partial displacement. Operating the BB motor at partial displacement for an extended time in the non-preferred direction will lead into motor failure.

2- and 4-speed BBC motors do not have preferred rotational direction and can be operated at maximum rated power in both directions.

In 2-speed BB and standard 2-speed BBC motors, a 15-30 bar control pressure to Y port is required to activate 2-speed (partial displacement of a 2-speed motor).

Depressurizing the Y port will return the motor to full displacement. Do not use work/high pressure in Y port to control a standard 2-speed BB or BBC motor.

BBC 05 4-speed motors have high pressure shift ports (Y1 and Y2). To shift such motor, the highest available system pressure has to be applied to the shift port. Typically this highest system pressure is taken from motor work lines A and B by a shuttle valve.

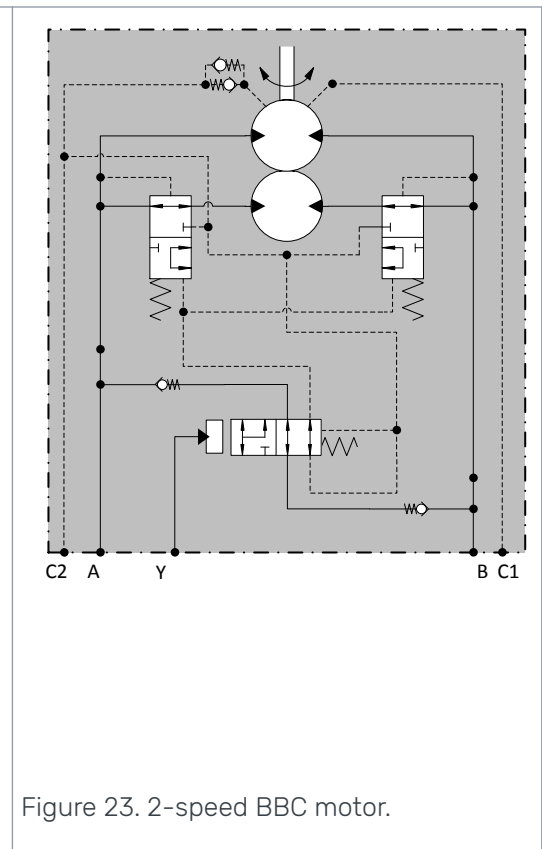
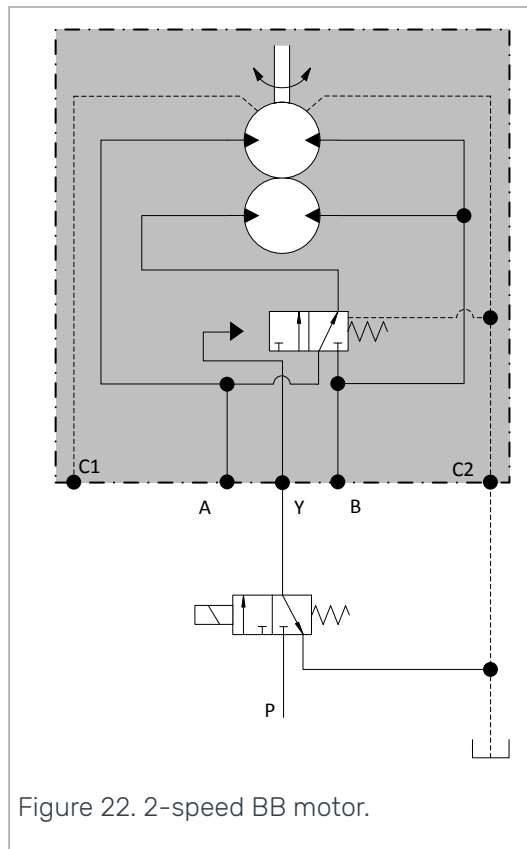

Attention:

Always use C2 port to connect the drain line of a multi-speed BBC motor. C1 can only be used for flush oil or to install an accumulator into the motor.



Attention:

Take the following things into consideration, when changing the speed range during motion.

- Hydraulic system supply must adjust to the rapid change of flowrate.
- The rapid change in flow rate may cause momentary jerk. This may be avoided by throttling the working lines lightly.
- Prevent operating conditions, in which the permissible performance values could be exceeded.

The permissible performance values are in the technical data (see [Technical data BB series](#) on page 10 and [Technical data BBC series](#) on page 12).



Attention:

Continuous use of high working pressure in the working line B at half displacement in BB 2-speed motors, may cause premature wear or failure of the motor.



Note:

Depressurize the 2-speed spool pilot Y to case drain line to prevent unwanted spool movement.

3.11 Seal protector and grease nipples

The seal protector is a standard feature in the BBC series motors (excluding the double brake motors). The seal protector is also known as a grease ring.

The seal protector prevents dirt and moisture from entering to the motor shaft seal. The operation of the seal protector is based on a sealing lubricant pocket.

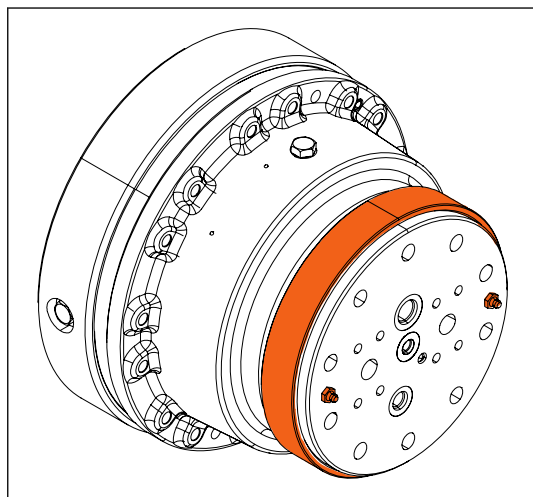

Figure 24. BBC motor's seal protector and grease nipples.

3.12 Brakes

There is a variety of brakes available for Black Bruin motors. Brakes, like motors, are designed in compact, powerful packages and tailored to meet the customer specific requirements in various applications.

3.12.1 Static wet multi-disc brake for BBC and BB series motors

The spring applied, pressure to release, wet multi-disc brake is a parking brake, but it can be used dynamically as an emergency brake.

For the minimum brake release pressure, refer to [Technical data BB series](#) on page 10 and [Technical data BBC series](#) on page 12. The brake operating pressure in BBC (low pressure brake) can not be higher than 30 bar. Depending on the Black Bruin frame size, the brake may have internal leakage (max. 0.6 l/min with oil viscosity of 35 cSt), which has to be considered in the brake circuit design. In BBC motors the brake can be manually released for emergency towing.

Standard, high pressure, BB brakes are equipped with static seals and do not have internal leakage. Note that EP, HD and some anti-wear additives in oil can cause remarkable reduction in brake torque.

Motor Description

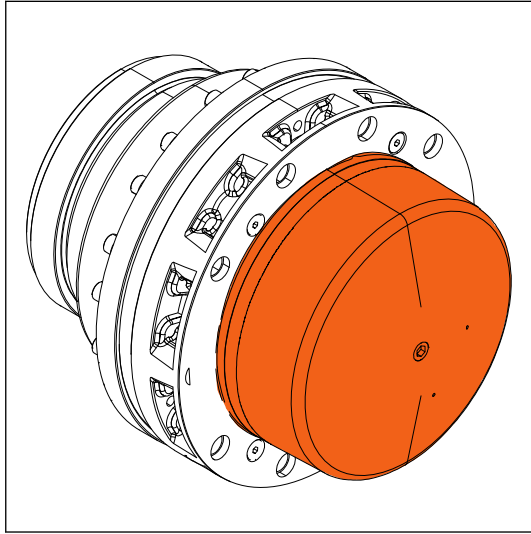

Figure 25. Static wet multi-disc brake

3.12.2 Double brake for BBC series motors

The double brake motor includes:

- A static wet multi-disc low pressure brake
 - Spring applied, pressure to release, parking brake
- A dynamic multi-disc brake
 - Pressure applied, spring release, service brake
 - The ultimate brake for the most demanding conditions
 - Cooling through flushing for dynamic use
 - Well-sealed structure isolating the brake from the environment and the motor from the brake

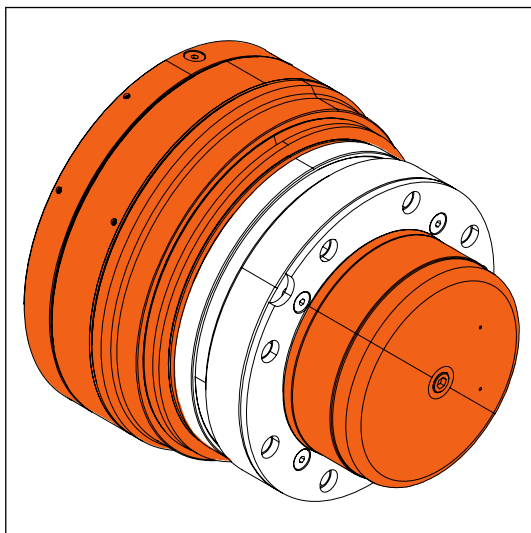

Figure 26. BBC motor's double brake

4 System Design

4.1 Motor hydraulic circuit

4.1.1 Simple connection

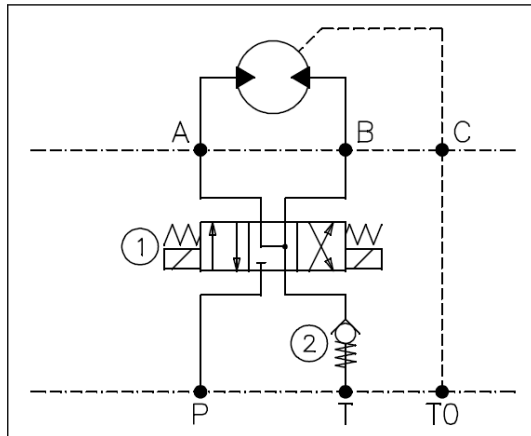

Figure 27. A simple motor hydraulic circuit in an open loop hydraulic system.

In an open loop hydraulic system the hydraulic circuit of the motor is usually implemented roughly as in the figure above.

- Select the operating direction with the directional control valve (1) by applying the working pressure (P) to the other working line (A or B).
- The minimum pressure (see [Working line pressure](#) on page 42) required in the return line (T) is created with the cracking pressure of the check valve (2).
- The case drain line port (C) is connected to the system reservoir (TO) as directly as possible.



Attention:

The case drain line of the motor must always be connected to a reservoir, even during freewheeling. The case pressure of the motor may rise significantly, if the motor is completely plugged during use.



Note:

Using the motor on a closed loop hydraulic system is different from the open loop system. The closed loop system is more complex, but enables more functions, such as hydrostatic braking, series connection and counter pressure operation.

4.1.2 Counter pressure operation

Counter pressure operation is needed mainly in series connection (see [Motors in parallel or series circuit](#) on page 39). Counter pressure operation means using the motor with high back pressure in the return line.

The counter pressure operation affects the torque output of the motor due to decreased pressure difference over the working lines.



Attention:

Make sure the combined pressure in the working lines does not exceed the permissible values of the working pressure during counter pressure operation.

Counter pressure operation is not recommended, because high back pressure stresses the motor more than usual operation.

4.1.3 Hydrostatic braking

Hydrostatic braking means using the output torque of the motor to decelerate the speed. The output torque is generated by closing the return line of the motor, in which case a working pressure will form in the return line. The minimum pressure and feed flow must be maintained in the feed line of the motor during hydrostatic braking.



Note:

The hydrostatic braking requires an active hydraulic fluid supply.



Danger:

Do not use the hydrostatic braking without relief valves in the working lines. When an external load is rotating the motor, the hydraulic pressure may increase indefinitely. This leads to danger if a hydraulic hose or component brakes under high pressure.

4.1.4 Short circuit operation

Short circuit operation means connecting the return flow of the motor directly to the feed line of the motor.

Short circuit operation is needed, if the motor must be rotated faster than the hydraulic system can supply and freewheeling the motor is not possible (see [Mechanical freewheeling](#) on page 27).

Make sure the minimum pressure is maintained in both working lines of the motor during short circuit operation.



Note:

The short circuit operation requires an active hydraulic fluid supply.



Attention:

Make sure the motor does not overheat during short circuit operation.

4.2 Hydraulic connections

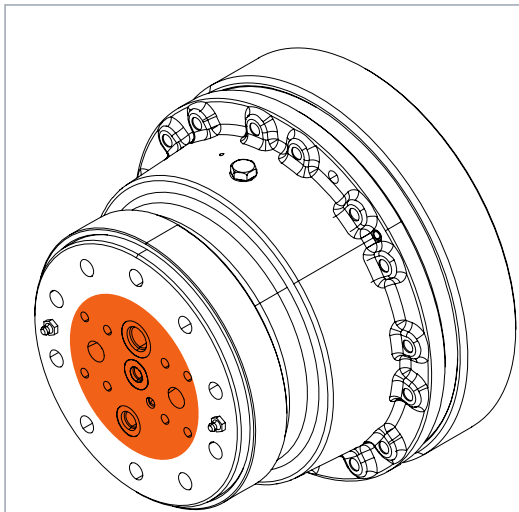

Figure 28. The interface of the motor hydraulics without a brake.

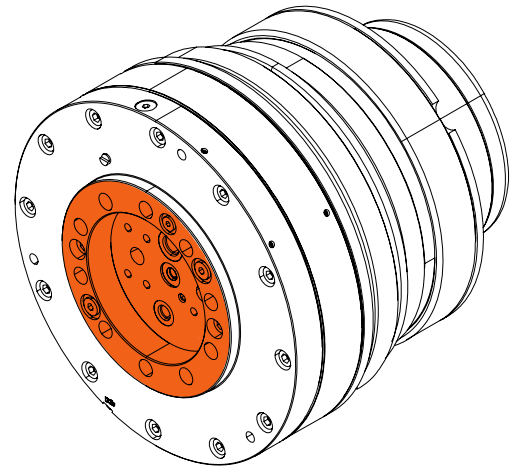

Figure 29. The interface of the motor hydraulics with the double brake.

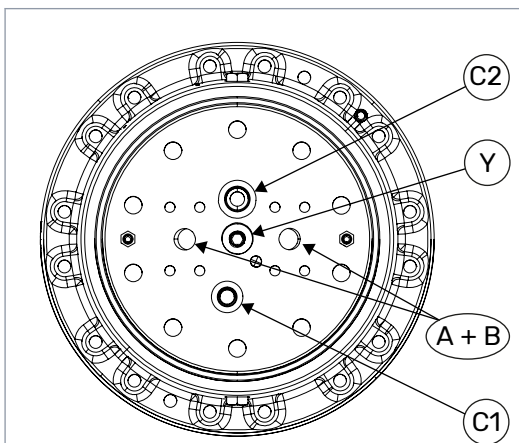

Figure 30. The hydraulic connections of a 2-speed BBC motor without a brake.

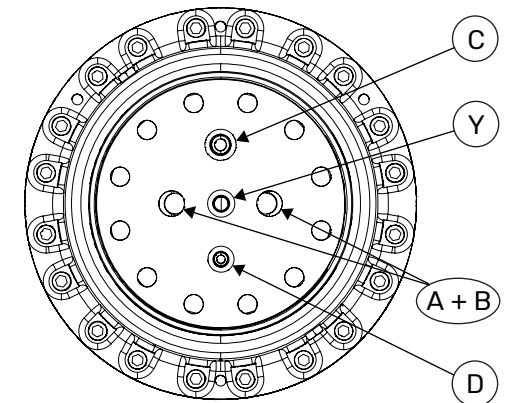

Figure 31. The hydraulic connections of a 2-speed BB motor with a brake.

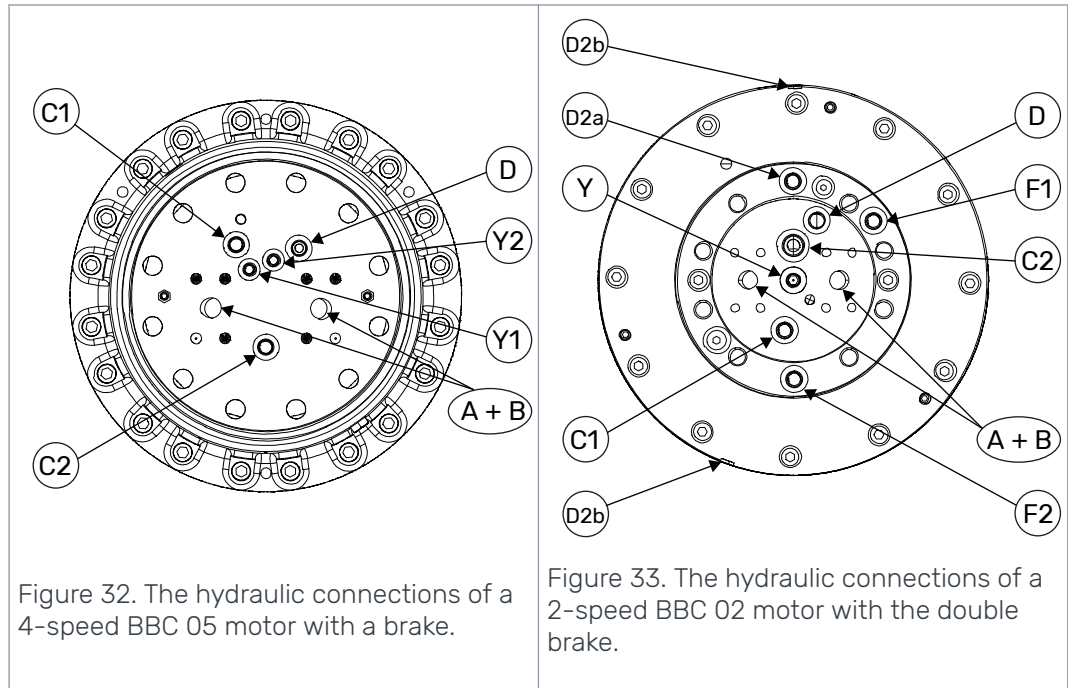

Figure 32. The hydraulic connections of a 4-speed BBC 05 motor with a brake.

Figure 33. The hydraulic connections of a 2-speed BBC 02 motor with the double brake.

All hydraulic connections of the motor are on the shaft mating surface.

- WORKING LINE PORTS (A and B)

The working lines, aka the feed and return lines of the motor are the high pressure lines meant for running the motor.

- CASE DRAIN LINE PORT (C or C2) and CASE FLUSHING LINE PORT (C1)

The case drain line is the return line from the housing cavity.

Most of the Black Bruin motors are equipped with the case flushing line (C1). The flushing line is an extra case line. From a charge pump, or an alternative source, cool oil from reservoir is fed into motor housing through the flushing line (C1).

The case drain line is marked with C. Motors with case flushing line C1 have a case drain line marked with C2. The case drain line is used for case drain and returning flush oil. To ensure motor functionality, C1 line has to be either plugged or used for flush flow in. C2 is always used for case drain flow out. Do not use C1 as case drain line.

- BRAKE PRESSURE PORTS (D, D2a and D2b)

The motors with parking brake have brake release line marked with D.

BBC motors with double brake have service brake pilot lines marked with D2a and D2b.

- BRAKE FLUSHING LINE PORTS (F1 and F2)

BBC motors with double brake have service brake flushing lines marked with F1 and F2.

- PILOT LINE PORTS (Y or Y1 and Y2)

The pilot line is meant for controlling a 2-speed or 4-speed motor (see [Multi-speed motors](#) on page 29).



Note:

The figures represent motor connections of specific models and are therefore only suggestive. For detailed information consult the motor manufacturer or its representatives.

4.3 External freewheeling valve

The external freewheeling valve is used for disengaging the motor during motion (see *Mechanical freewheeling* on page 27).

The freewheeling valve should be normally open, so that the motor will disengage when the control system is off.

When the motor is disengaged the case drain port (C) should be connected as directly as possible to the working line ports A and B.

There are multiple possibilities for the external freewheeling valve. Some examples of these possibilities are described in this chapter.

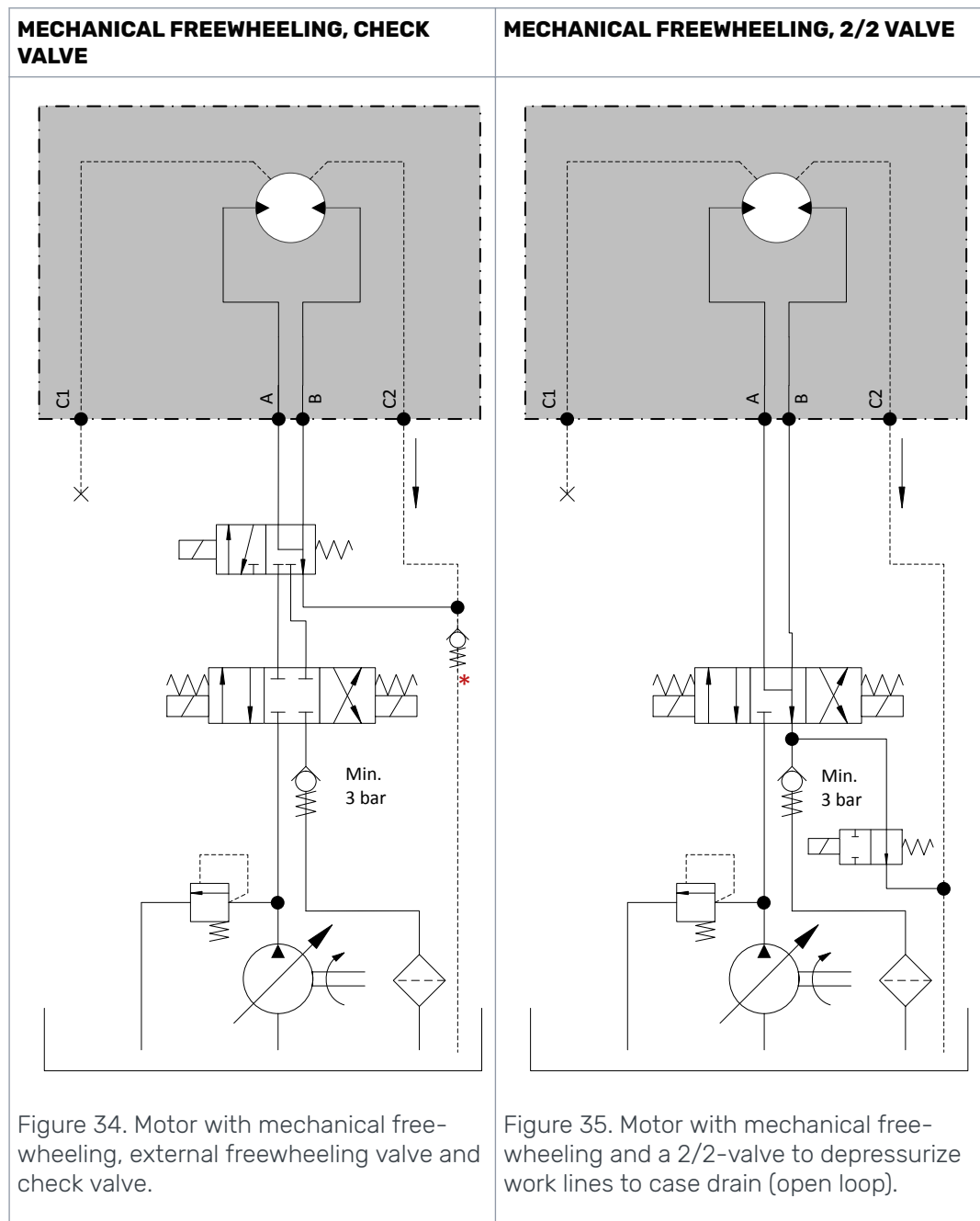

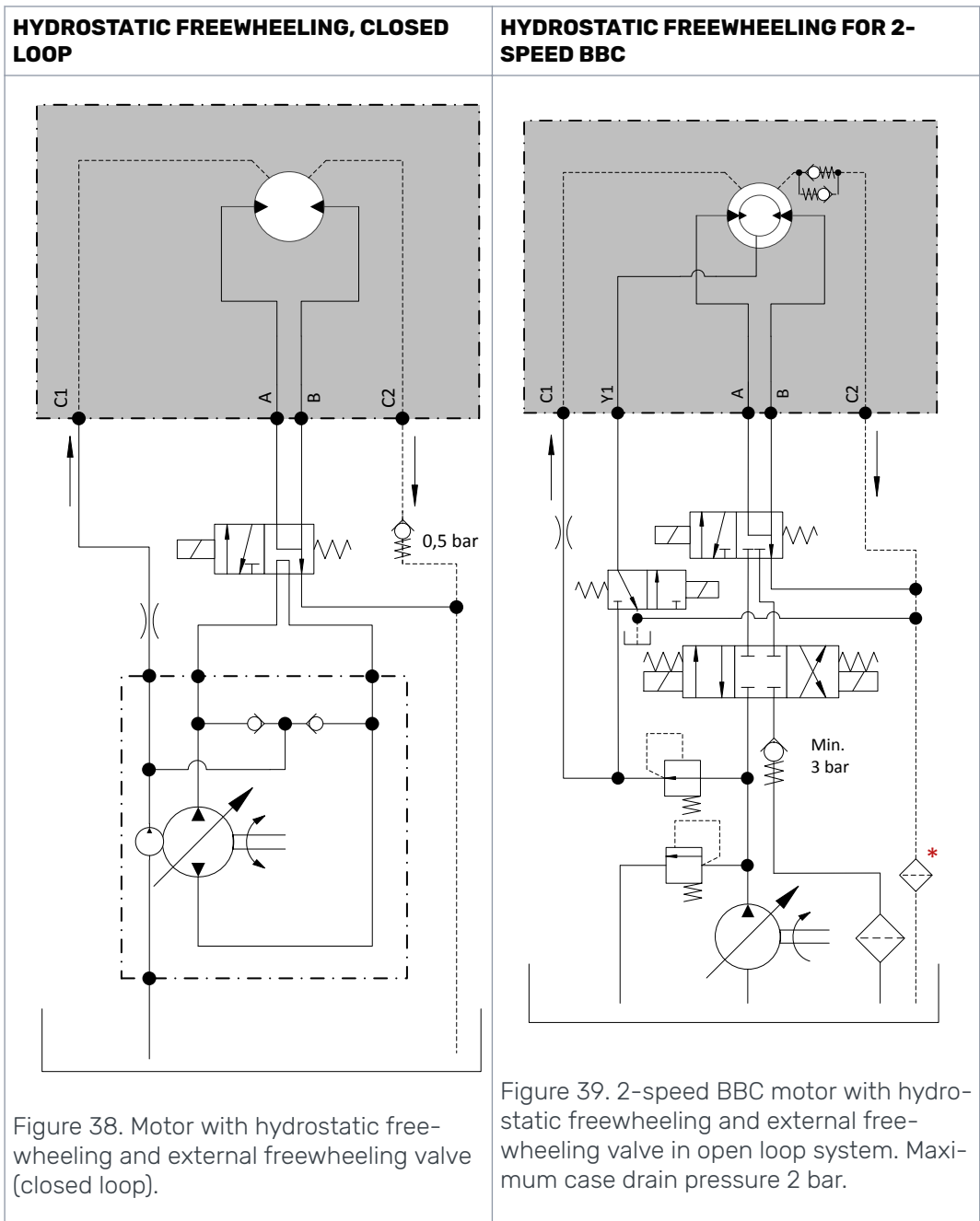

4.4 Hydraulic fluid

4.4.1 Motors in parallel or series circuit

The traction of a vehicle may be increased by connecting multiple motors in parallel or in series.

A single powered wheel may transmit only a certain amount of power to traction. By dividing the power to multiple wheels, the vehicle gets more traction. This is advantageous especially in slippery operating conditions.

PARALLEL CIRCUIT

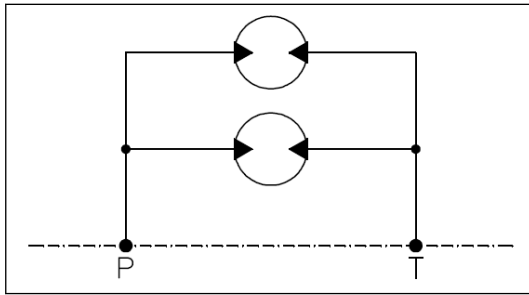

Figure 40. Two motors in parallel circuit.

Two motors in parallel circuit generate double torque and run half slower than one motor with the same flow rate and pressure.



Note:

The flow distribution of the motors must be ensured, if the operating conditions are very slippery or if some of the powered wheels carry much smaller load. The system prefers to rotate only the motor, which has the least resistance.

The flow distribution may be done by sizing the working lines to a certain flow rate or by throttling them slightly.

Ordinary flow divider valve can not be used in most cases, because its resistance of flow increases too much as the speed of the vehicle increases.

The flow distribution is usually required only when starting to move the vehicle. A reliable solution is a flow divider valve, which can be bypassed or switched on when necessary.

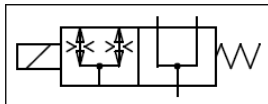

Figure 41. A pilot controlled flow divider valve.

SERIES CIRCUIT

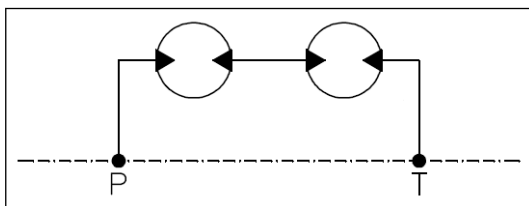

Figure 42. Two motors in series circuit.

Two motors in series circuit generate same torque and rotate as fast as one motor with the same flow rate and pressure.



Attention:

The minimum pressure and a sufficient feed flow must be ensured for all motors.

The use of series circuit is challenging and therefore is not recommended.

4.4.2 Hydraulic fluid type

Black Bruin hydraulic motors are designed to work with hydraulic fluids based on mineral oil. Consider the following requirements when choosing hydraulic fluid:

- Hydraulic oils in accordance with ISO 6743-4 are recommended to be used.
- Motor oils in accordance with API-grades SF, SG, SH and SL may also be used.
- Fire resistant hydraulic fluids HFB and HFC or similar may be used under certain circumstances.

4.4.3 Hydraulic fluid properties

Requirements concerning the hydraulic fluid properties:

- The recommended fluid viscosity range for constant use is 25 - 50 cSt.
- The minimum permissible intermittent viscosity is 15 cSt.
- The maximum permissible viscosity during motor startup is 1000 cSt.
- The viscosity index must be at least 100.
- The water content of hydraulic oil should be less than 500 ppm (0,05 %).
- The hydraulic fluid must reach score 10 on a wear protection test FZG A/8,3/90 in accordance with ISO 14635-1 (DIN 51354)
- The effect of the additives improving the viscosity index can decrease during operation.



Note:

Temperature has a significant effect on the viscosity and the lubricating capability of the hydraulic fluid. Take into consideration the real operating temperature when defining the fluid viscosity.

The need for service and the overall service life may be improved by using hydraulic fluids with higher viscosity. In addition higher viscosity may improve the running smoothness.

4.4.4 Hydraulic fluid cleanliness

Hydraulic fluid must fulfill cleanliness level 18/16/13 in accordance with ISO 4406 (NAS 1638 grade 7).



Note:

The purity of the hydraulic fluid has a significant effect on the need for service and the overall service life of the motor.

4.5 Operating pressures

4.5.1 Case pressure

The case pressure of the motor affects the lifetime of the sealing. It is recommended to maintain as low case pressure as possible.

When the motor is running, the permissible average case pressure is 2 bar and the highest permissible intermittent case pressure is 10 bar.

When the motor is not running, the highest permissible constant case pressure is 10 bar.

Make sure that the motor case is always full of oil.



Attention:

Running the motor with higher than allowed case pressure shortens the service life of the motor.



Note:

The lifetime of the sealing may be improved with an accumulator, which cuts the pressure peaks that are higher than the pre-charge pressure of the accumulator.

Recommended pre-charge pressure is 2 bar and the displacement should be about 25 % of the motor displacement. The accumulator should be connected to the case drain line port as close to the motor as possible.

If motor is placed above the reservoir, add check valve with 1 bar (15 psi) pressure to case drain line to ensure case oil fill. Maximum continuous case pressure 2 bar.

4.5.2

Pilot pressure

BB motors	BBC motors
404VVVY 2/3 40	C2V 2 E1Y0AA
405VVVY 2/3 40	C3V 2 E1Y0AA
406VVVY 2/3 40	C5V 2 E1Y0AA
407VVVY 2/3 40	C5V 7 E1Y0AA

The pilot pressure is used to engage the options of the multi-speed motors.

The recommended pilot pressure is 15 to 30 bar and the maximum allowed pilot pressure is 350 bar.



Attention:

Over 30 bar pilot pressure causes case pressure peaks. This effect should be minimized with an orifice in the pilot line. Recommended orifice size is 1 mm.

4.5.3

Working line pressure

WORKING PRESSURE

The working pressure is the high pressure that generates the output torque of the motor. The following values for the working pressure are in the technical data (see [Technical data BB series](#) on page 10 and [Technical data BBC series](#) on page 12):

- PEAK PRESSURE

The value of the peak pressure is the maximum allowed value of the working pressure. Make sure the working pressure does not exceed this value under any circumstances.

- INTERMITTENT PRESSURE

The value of the intermittent pressure is a permissible value of the working pressure for a reference period of one minute (1 min). The working pressure may exceed this value for 10 % of the time during the reference period (for 6 seconds).

MAXIMUM PRESSURE

Unless governed by the power limit, oil temperature or oil viscosity, the maximum pressure is the maximum continuous work pressure.

Motor life depends on average speed and pressure. The higher the pressure, the shorter the expected life. For Lh10 calculations, please consult the manufacturer.

MINIMUM PRESSURE

The minimum pressure is a low pressure required in the working lines, which ensures the motor stays engaged when running. The motor is engaged when the pistons of the motor stay constantly connected to the cam ring. The minimum pressure guarantees continuous contact between cam rollers and cam ring.

The minimum pressure is maintained with charge pressure. Type of the hydraulic system affects the implementation.

- **CHARGE PRESSURE**

In closed loop hydraulic system the charge pressure is usually used as the minimum pressure.

In open loop hydraulic system the charge pressure may be done by a suitable pressure reducing valve.



Attention:

Too low pressure in the working lines causes the pistons to disconnect from the cam ring when the motor is running. The effect of this is clattering noise when the pistons reconnect.

Constant use with too low working line pressure may cause premature wear or failure of the motor.



Note:

Minimum work line pressure values are given at zero case pressure. To calculate system specific minimum pressure, add case pressure to the minimum pressure value from the chart.

The required minimum pressure depends on the rotational speed and case pressure. Recommended values for the minimum pressure at zero case pressure are on the following figures:

BB series motors

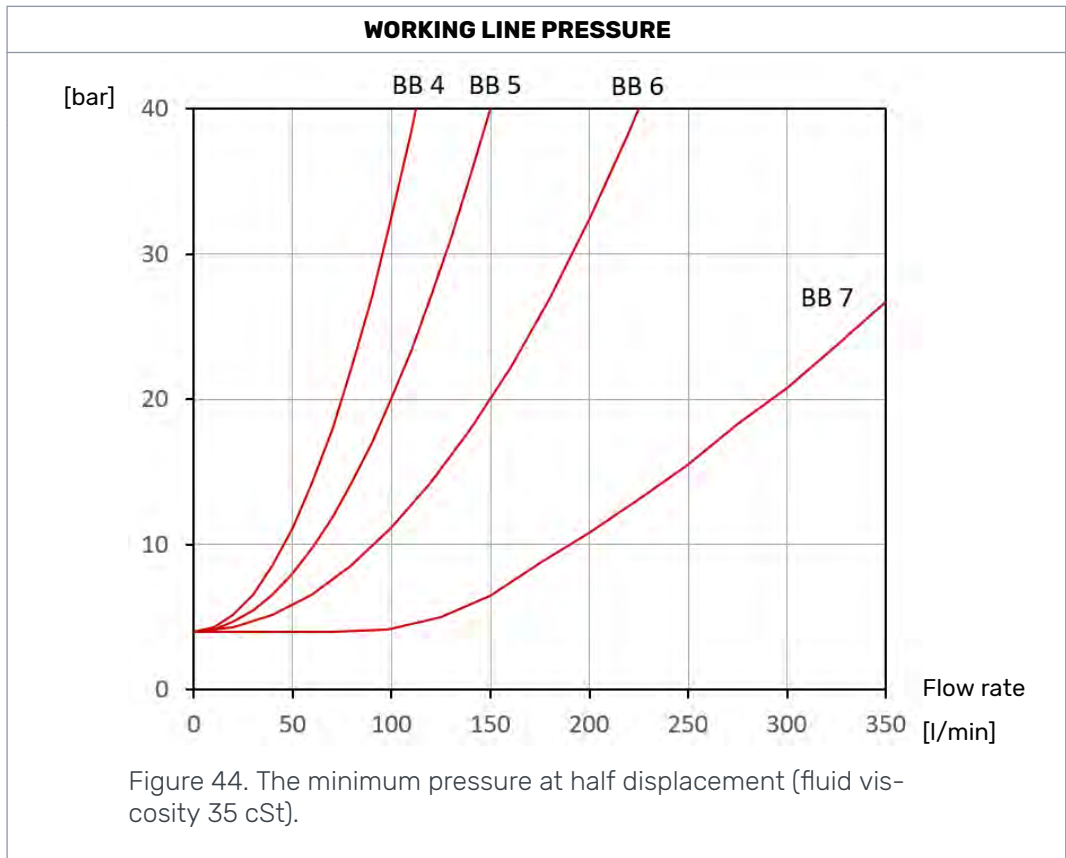
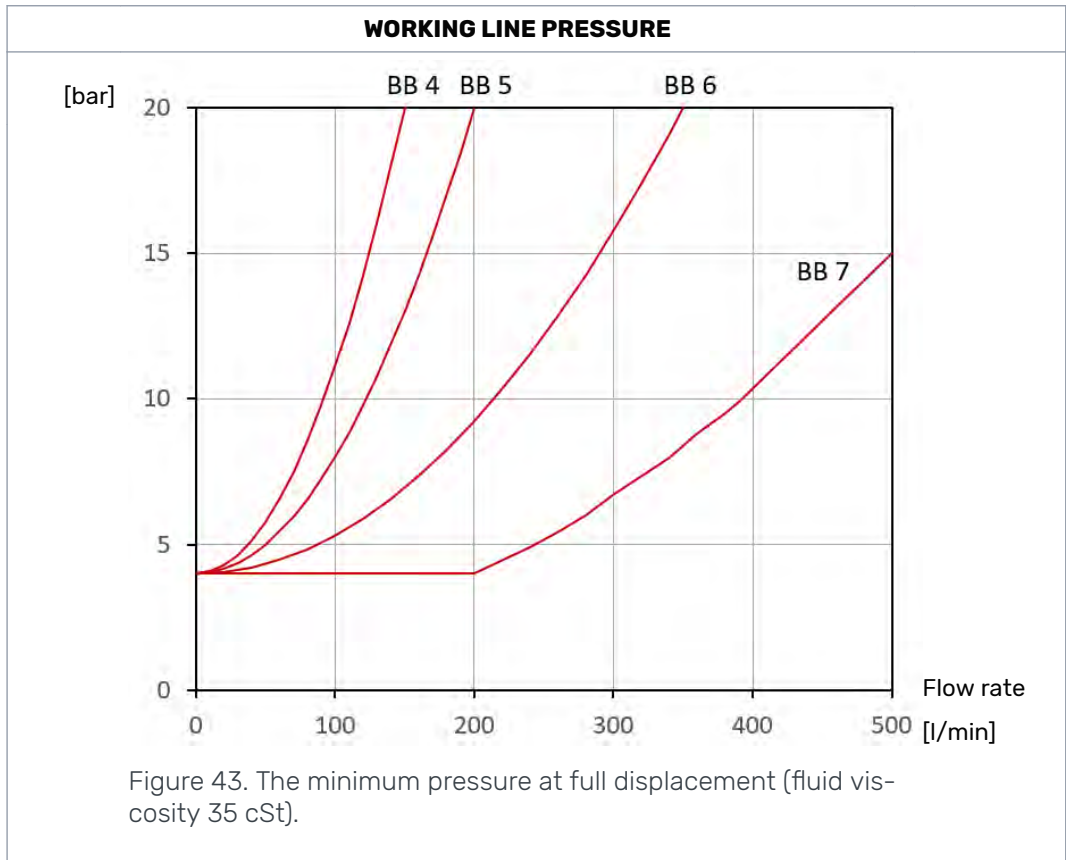

BBC series motors

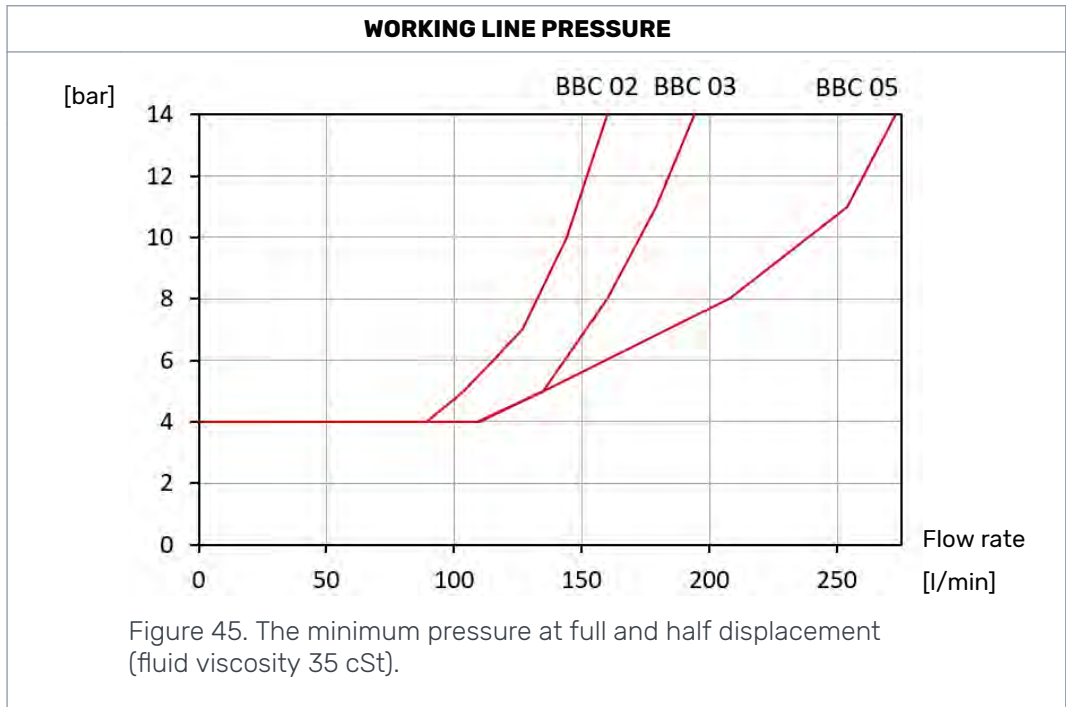

5 Motor Sizing

5.1 Load carrying capacity

5.1.1 Wheel offset

The load carrying capacity of the motor is defined by the offset value (a) of the wheel rim and the application specific safety factor.

The offset value is the distance from the wheel center line (CL) to the motor shaft interface. The load charts of the motors are given as a function of offset value. The given load curves refer to the average wheel load on a single motor.

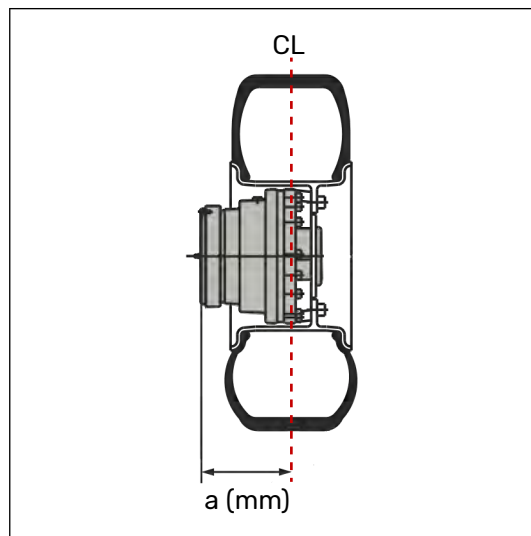

Figure 46. Measurement of the wheel offset (a).



Attention:

The motor load carrying capacity is applicable when the C or C2 port is orientated to the load direction (excluding the 4-speed motors).

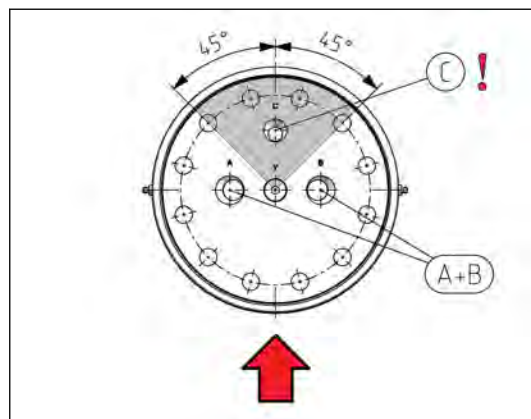

Figure 47. Motor orientation to the load direction.

5.1.2 Allowed wheel load

The allowed wheel load is based on the fatigue strength of the shaft (curved part) and the load carrying capacity of the screw joints (flat part). The maximum allowed wheel load depends on the load point. With applications combining high radial and axial loads, please consult the motor manufacturer or its representative to determine maximum permissible loading.

BB series motors:

BB 4: $F_{max} \geq \alpha \times F_r + 5,3 \times r \times F_a$

BB 5: $F_{max} \geq \alpha \times F_r + 4,6 \times r \times F_a$

BB 6: $F_{max} \geq \alpha \times F_r + 4,0 \times r \times F_a$

BB 7: $F_{max} \geq \alpha \times F_r + 3,4 \times r \times F_a$

BBC series motors:

BBC 2: $F_{max} \geq \alpha \times F_r + 5,62 \times r \times F_a$

BBC 3: $F_{max} \geq \alpha \times F_r + 5,41 \times r \times F_a$

BBC 5: $F_{max} \geq \alpha \times F_r + 4,45 \times r \times F_a$

Dynamic factor (α):

- constant loading at low speed, $\alpha = 1$
- variable loading, $\alpha = 1 - 1,5$
- shock loads or high speed (for > 70 km/h or 45 mph), $\alpha = 1,4 - 2$

BB series motors

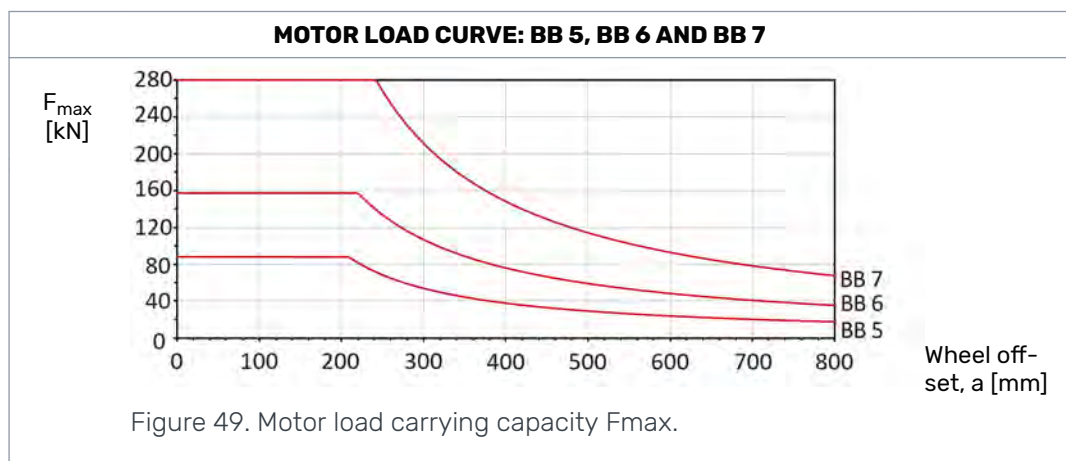
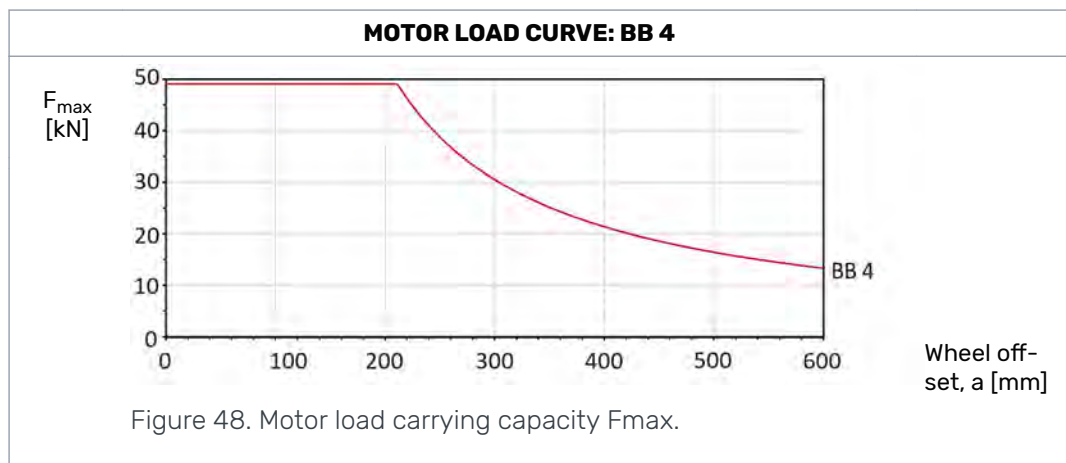

BBC series motors

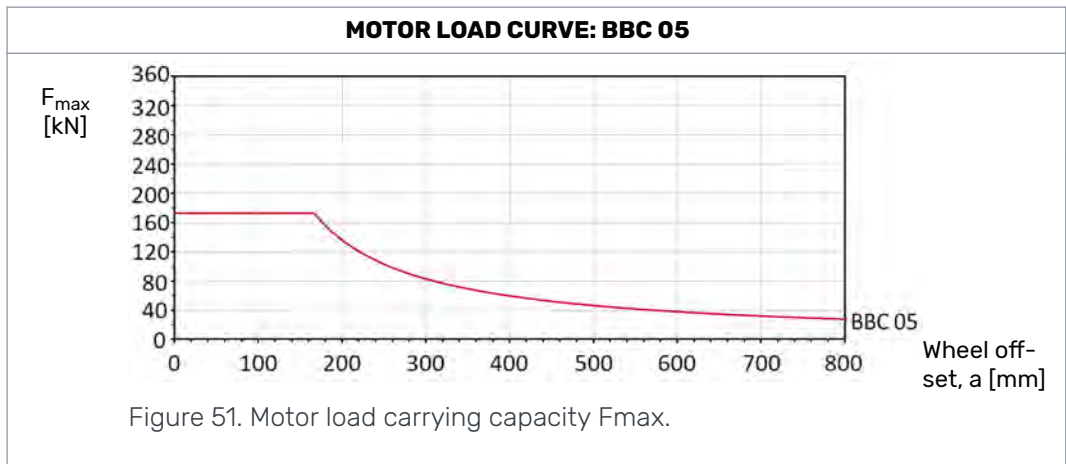
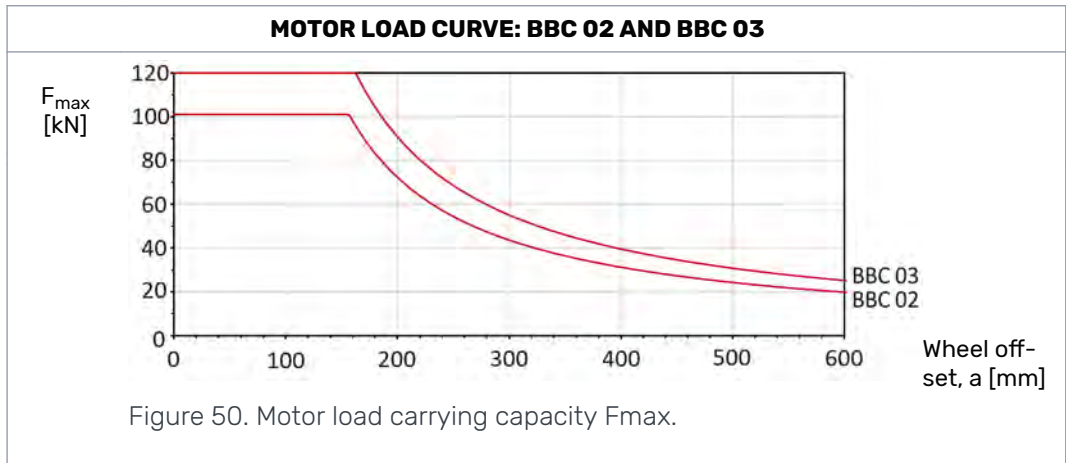

5.1.3

Service life

The service life of the motor is based on the rated life of its bearings. The bearings load curve gives the wheel load value, which the motors endures for 10 million rotations with 90 % reliability.

The service life may be estimated with the following equation:

$$L_{10h} = \frac{166\,667}{\text{RPM}} \cdot \left(\frac{F_{10m}}{F_r} \right)^{\frac{10}{3}}$$

L_{10h} = nominal service life [h]
 RPM = rotating speed [rpm]
 F_r = average wheel load [kN]
 F_{10m} = bearing load carrying capacity [kN]

BB series motors

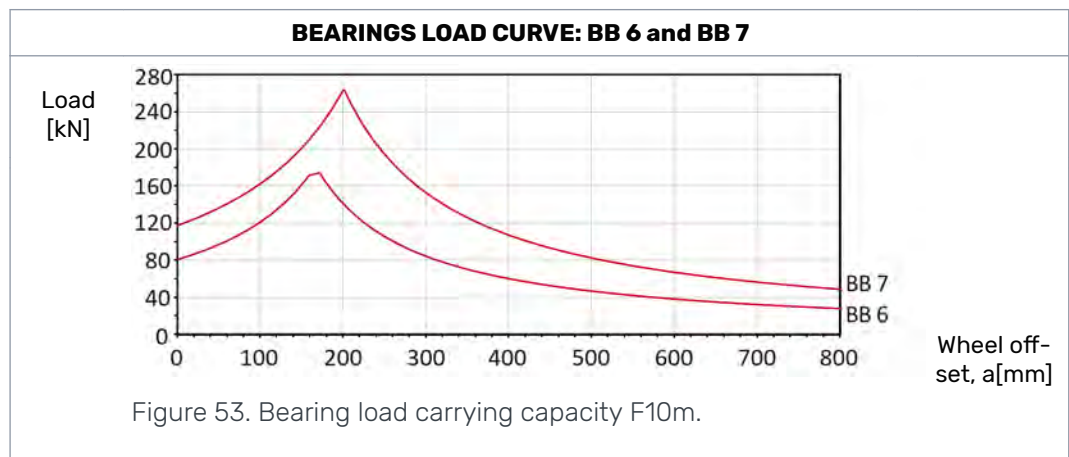
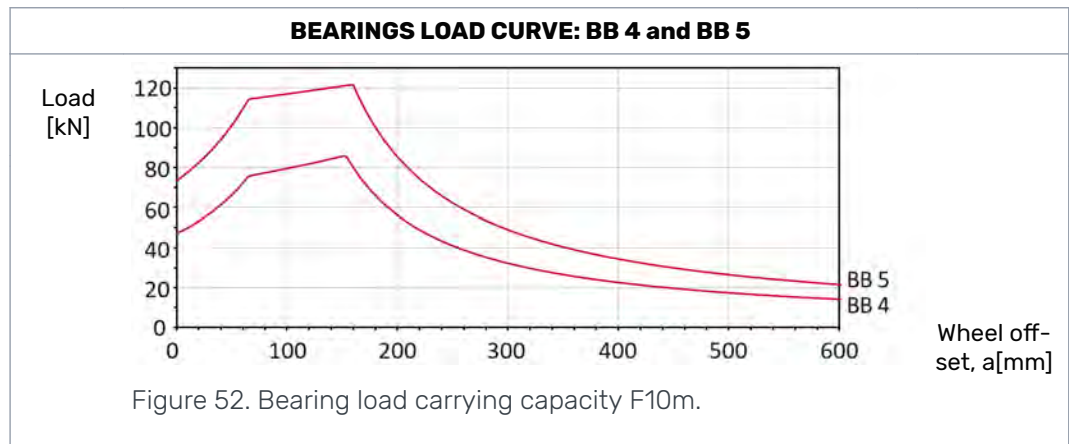

BBC series motors

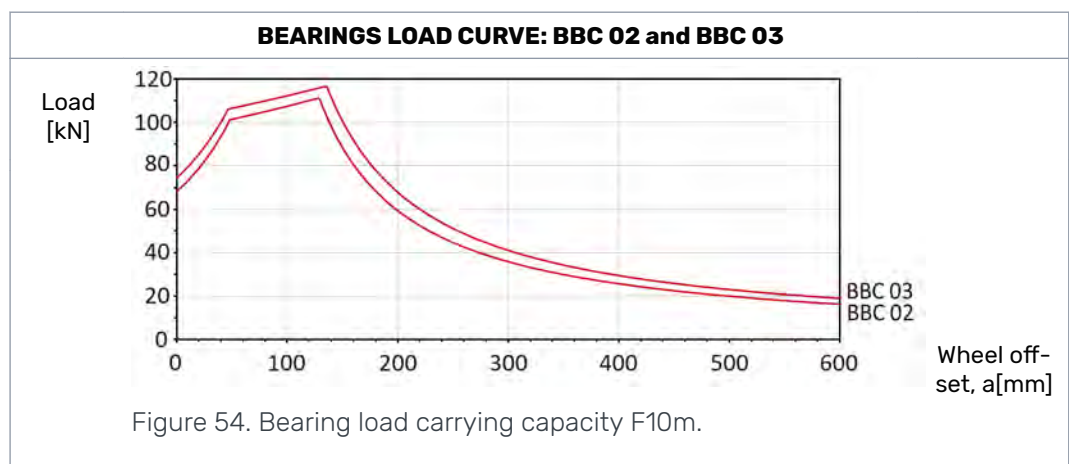

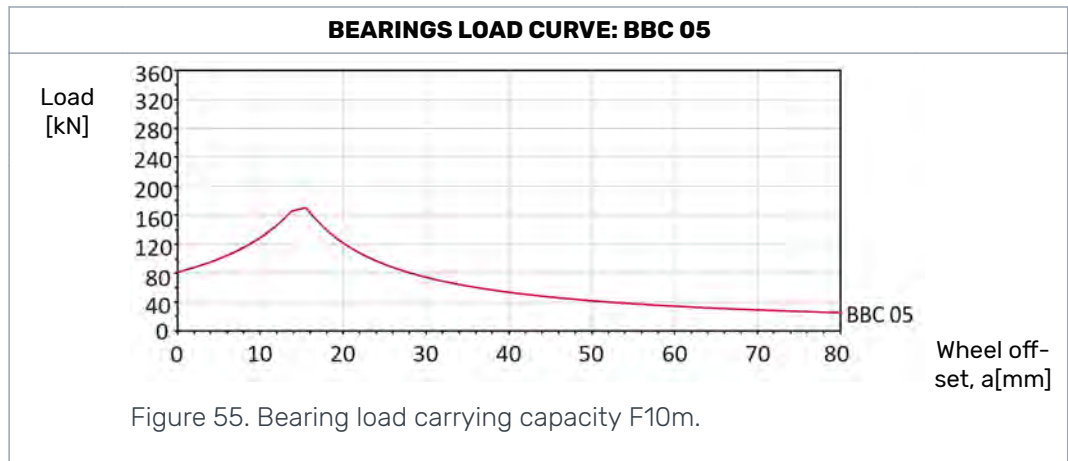

5.2 Performance

5.2.1 Rotating speed and flow rate

Rotating speed of the motor and required flow rate may be calculated with the following equations:

ROTATING SPEED

$$\text{RPM} = 1000 \cdot \frac{Q}{V}$$

or

$$\text{RPM} = 2653 \cdot \frac{\text{KMH}}{R}$$

or

$$\text{RPM} = 9549 \cdot \frac{\text{MPS}}{R}$$

FLOW RATE

$$Q = \frac{\text{RPM} \cdot V}{1000}$$

RPM = rotating speed [rpm]
 KMH = vehicle speed [km/h]
 MPS = vehicle speed [m/s]
 R = wheel radius [mm]
 V = displacement [ccm]
 Q = flow rate in working lines [l/min]



Note:

Due to motor dynamics, a constant smooth operating speed of under 2 rpm may be difficult to achieve.

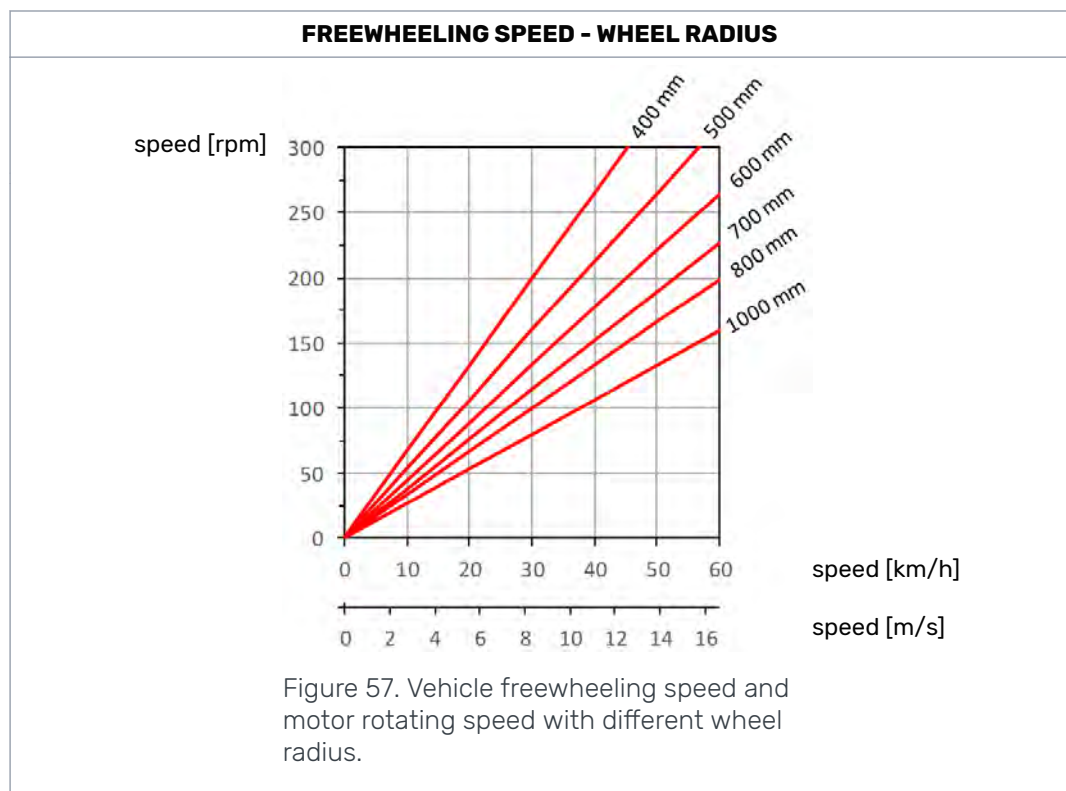
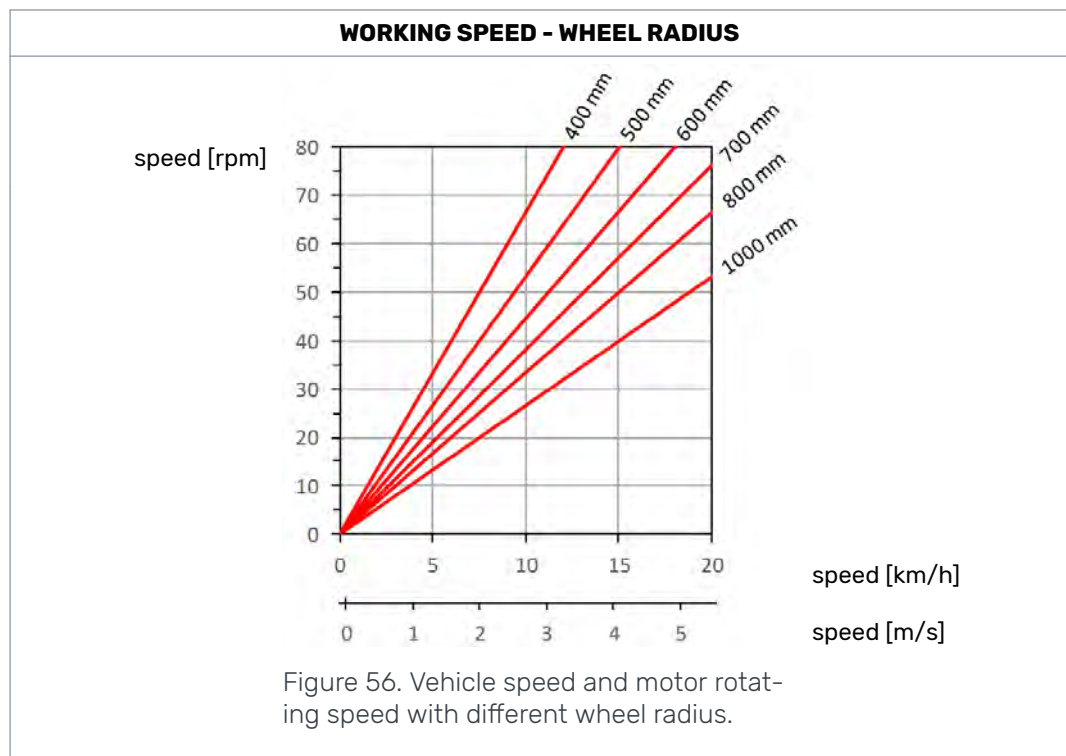

5.2.2 Torque

The output torque of the motor is generated by the pressure difference of the working lines (pressure difference between ports A and B)

The output torque of the motor may be estimated with the following equations:

MAXIMUM TORQUE	
$T_{max} = 0,01592 \cdot V \cdot \Delta p$	T = torque [Nm]
STARTUP TORQUE	
$T_o = 0,75 \cdot T_{max}$	V = displacement [ccm]
	Δp = pressure difference [bar]

5.2.3 Power

The operating power of the motor should be determined for all operating conditions. The operating power may be calculated with the following equation:

$P = \frac{Q \cdot p_w}{600}$	P = power [kW]
or	Q = flow rate in working lines [l/min]
$P = \frac{V \cdot RPM \cdot p_w}{600\,000}$	RPM = rotating speed [rpm]
	V = displacement [ccm]
	p_w = working pressure [bar]



Note: Rough estimate of the operating power may be checked by dividing the available hydraulic power between the motors.

5.3 Performance charts

5.3.1 BB motors performance curves

BB 4

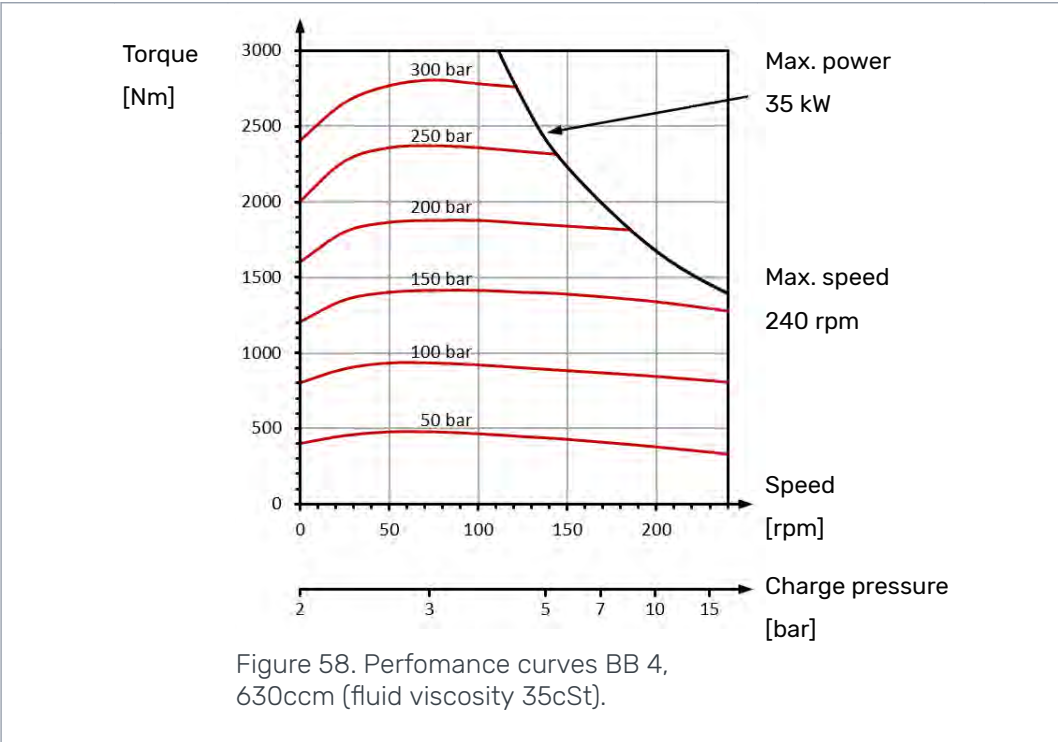
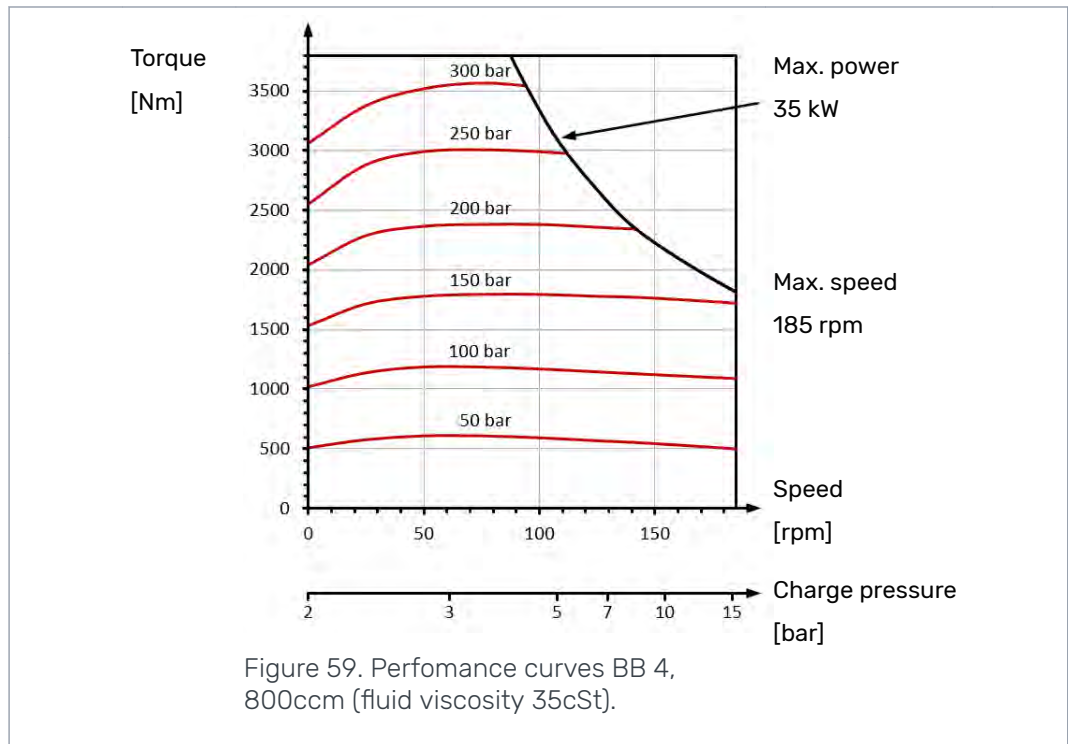
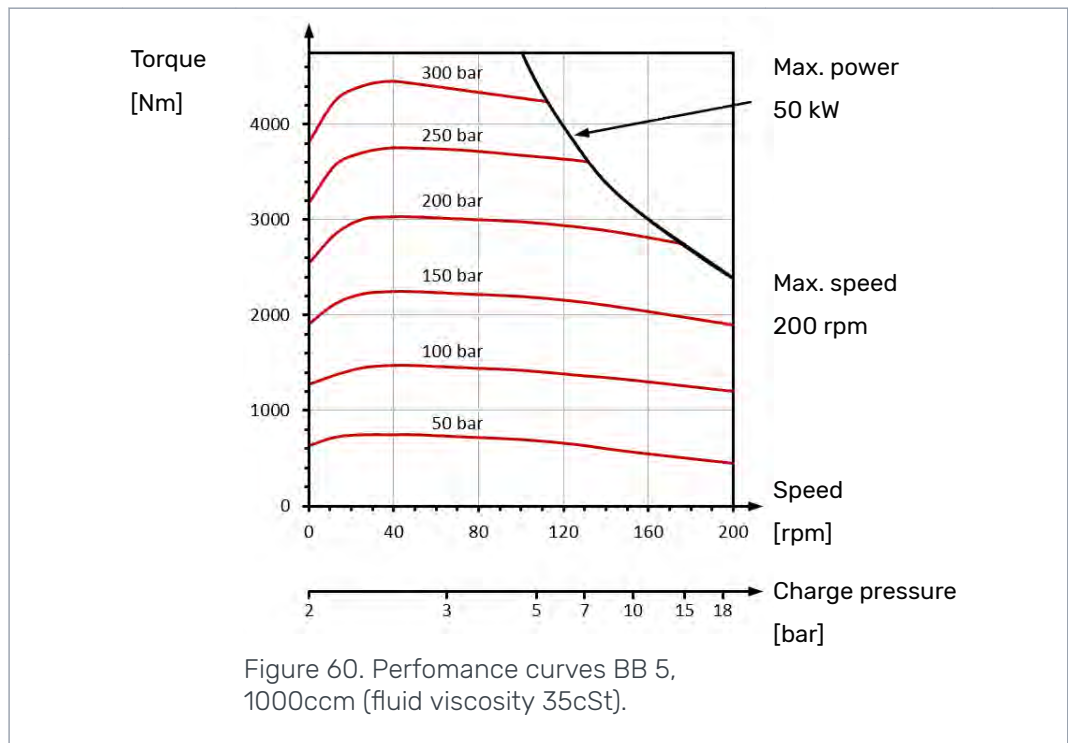

Figure 58. Performance curves BB 4, 630ccm (fluid viscosity 35cSt).



BB 5



Motor Sizing

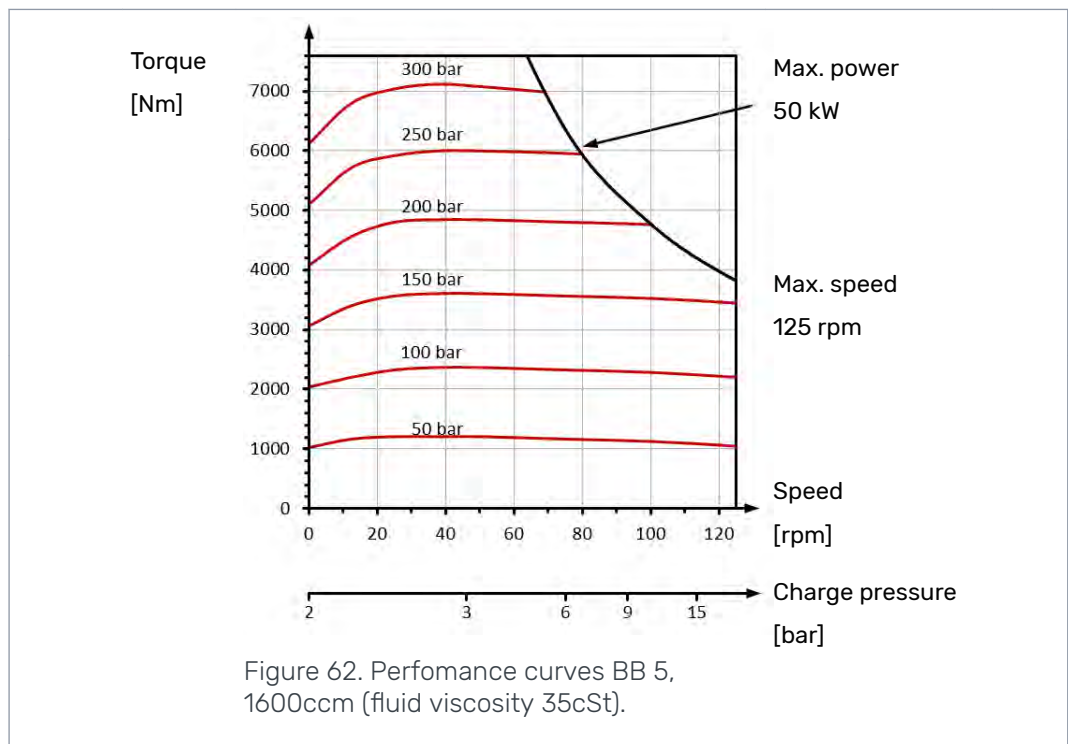
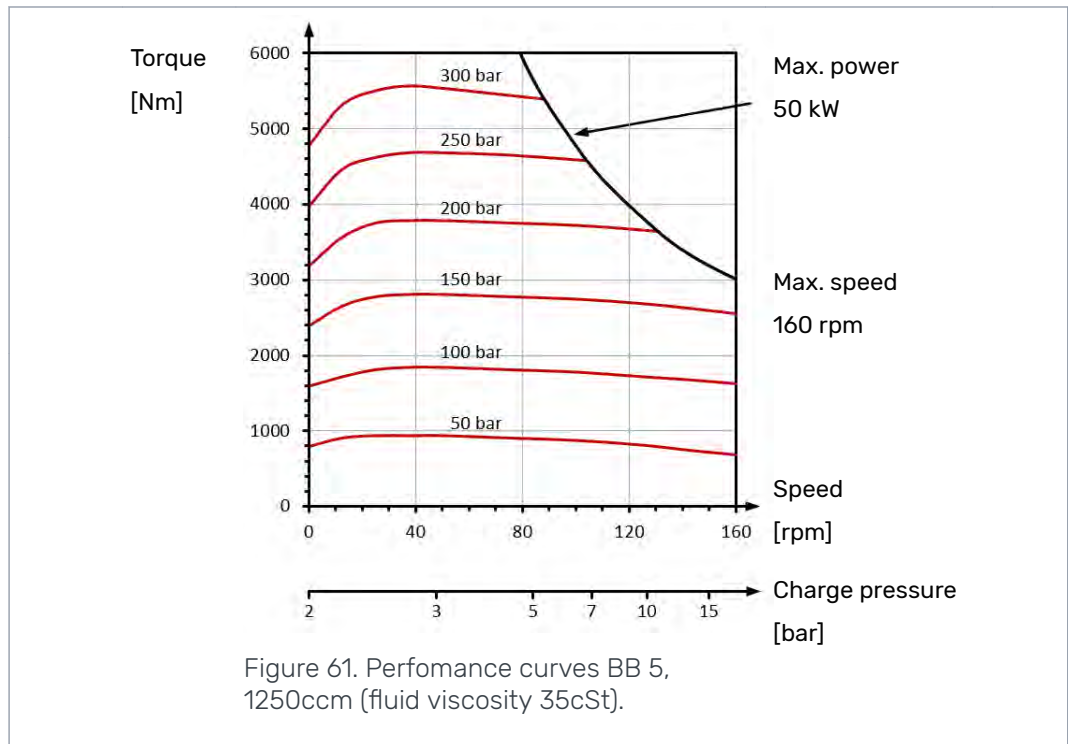

BB 6

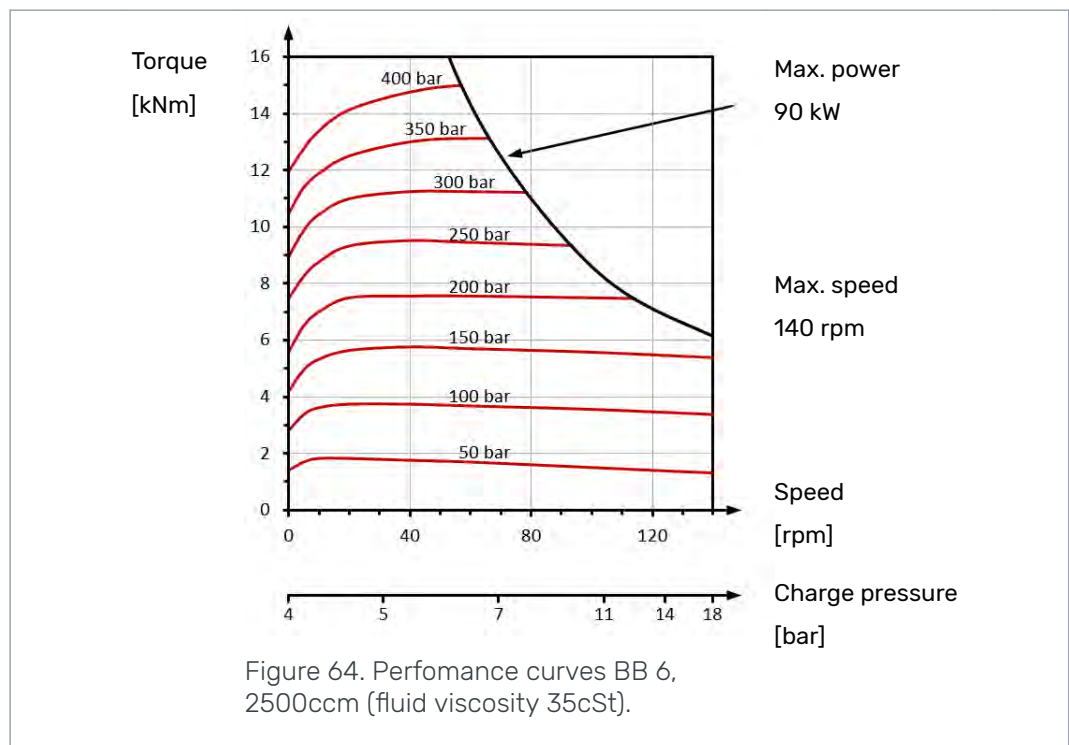
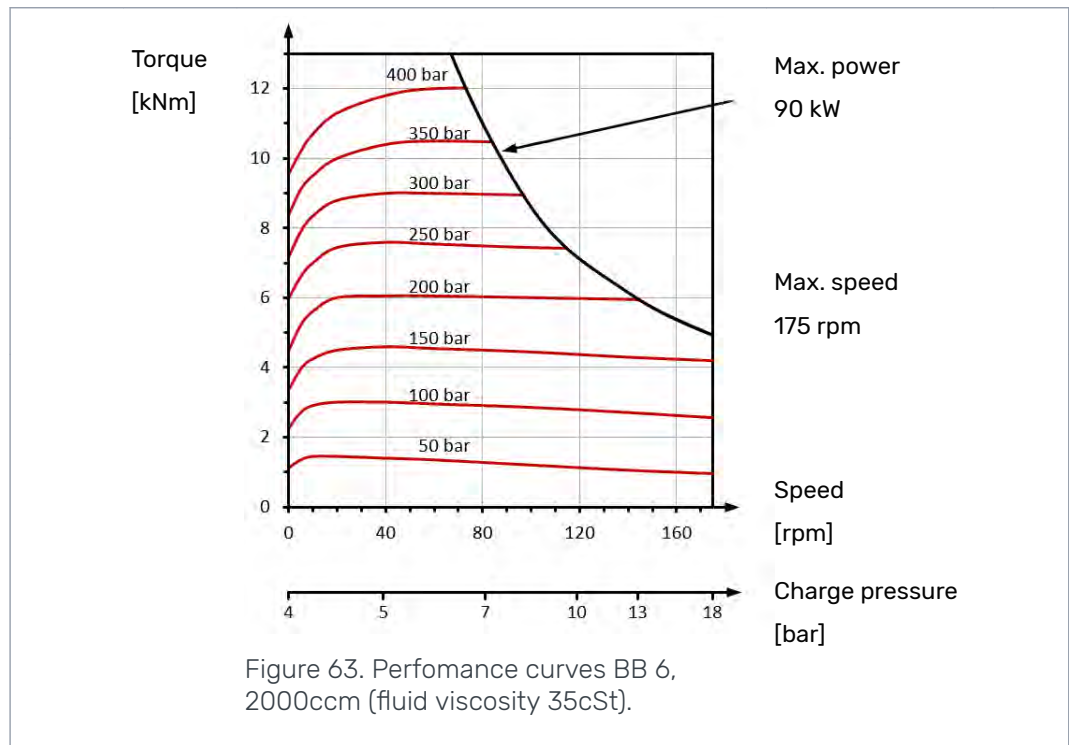

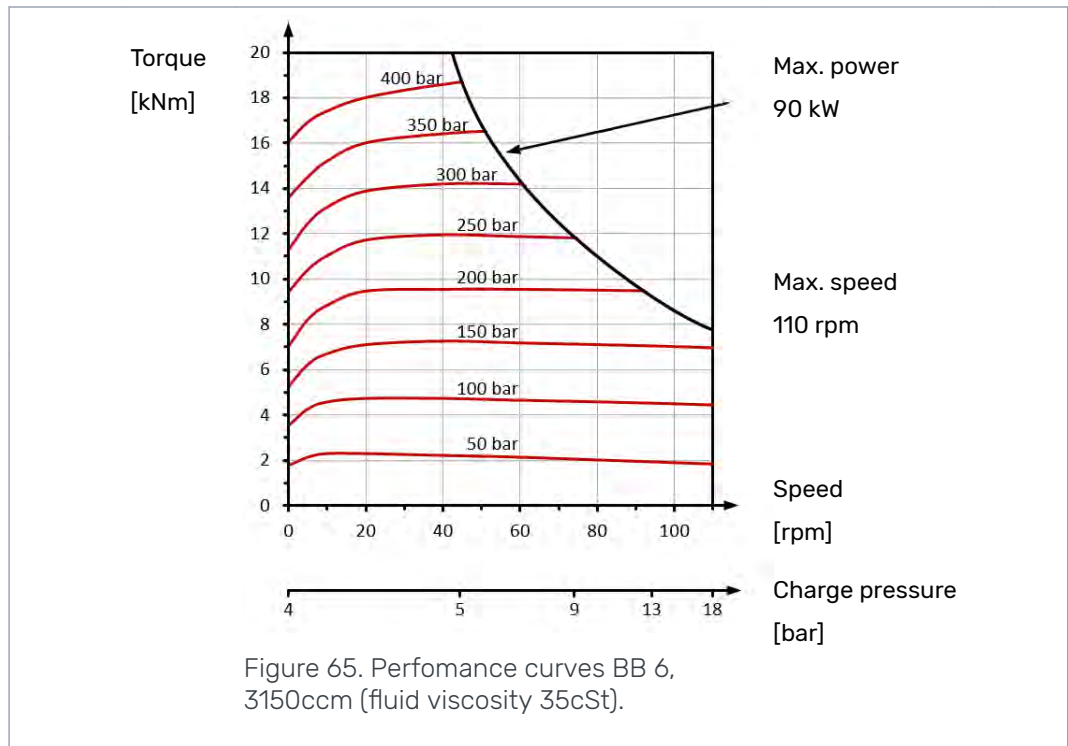

BB 7

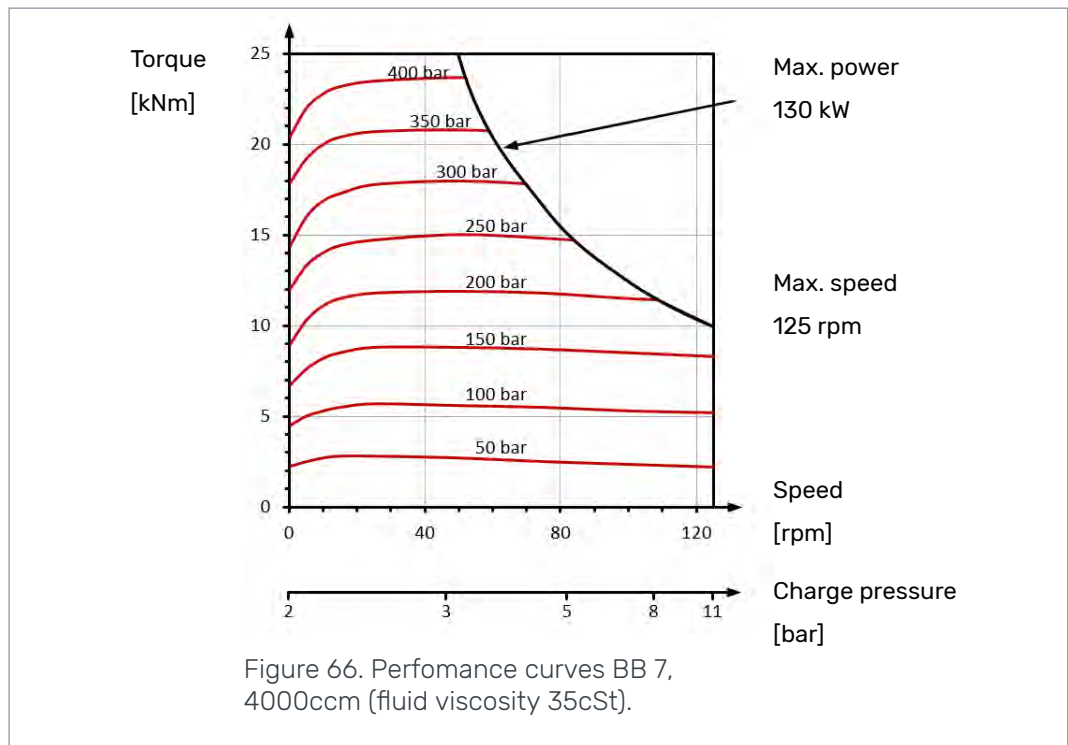

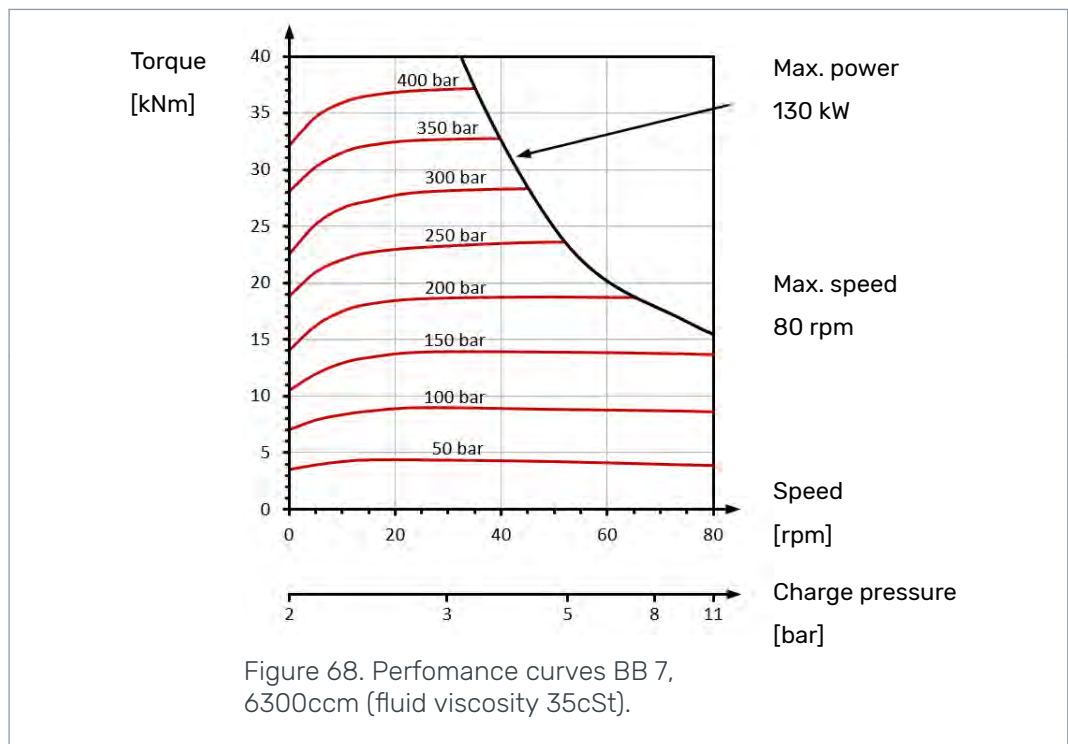
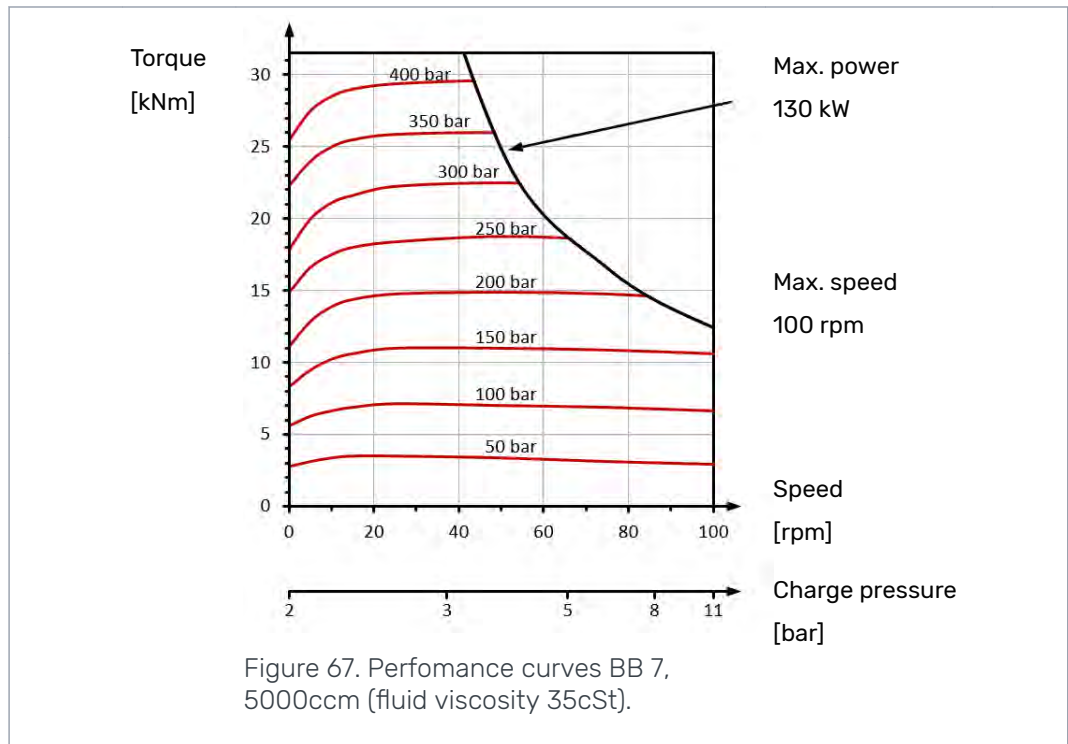

5.3.2 BBC motors performance curves

BBC 02

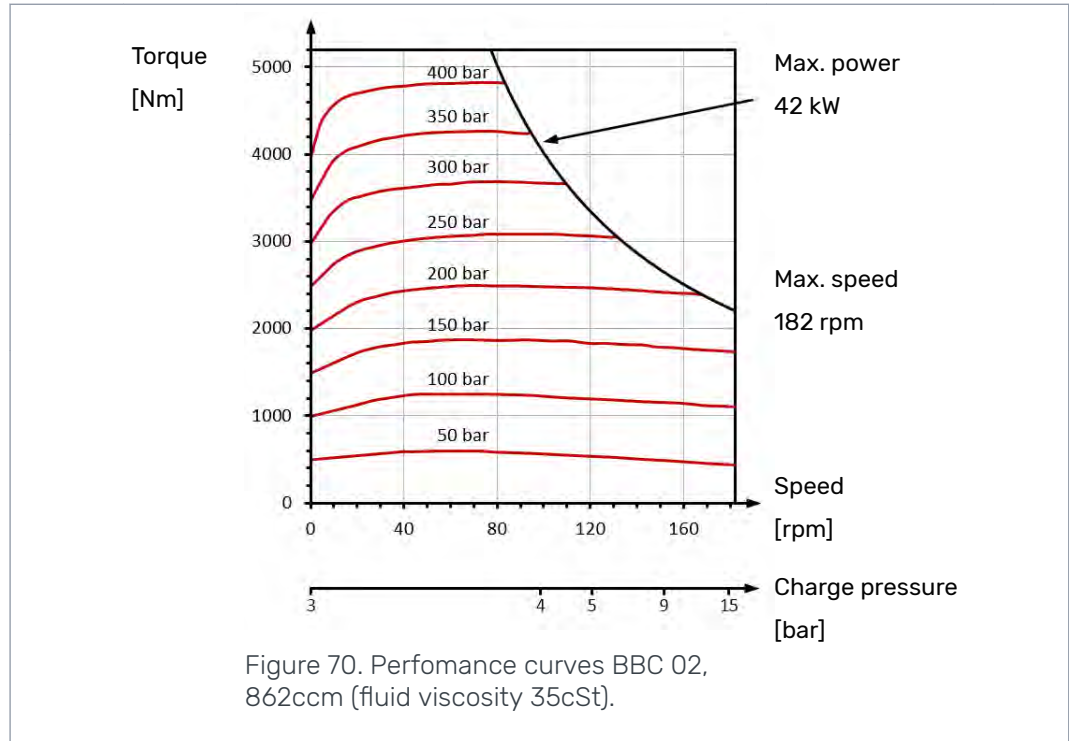
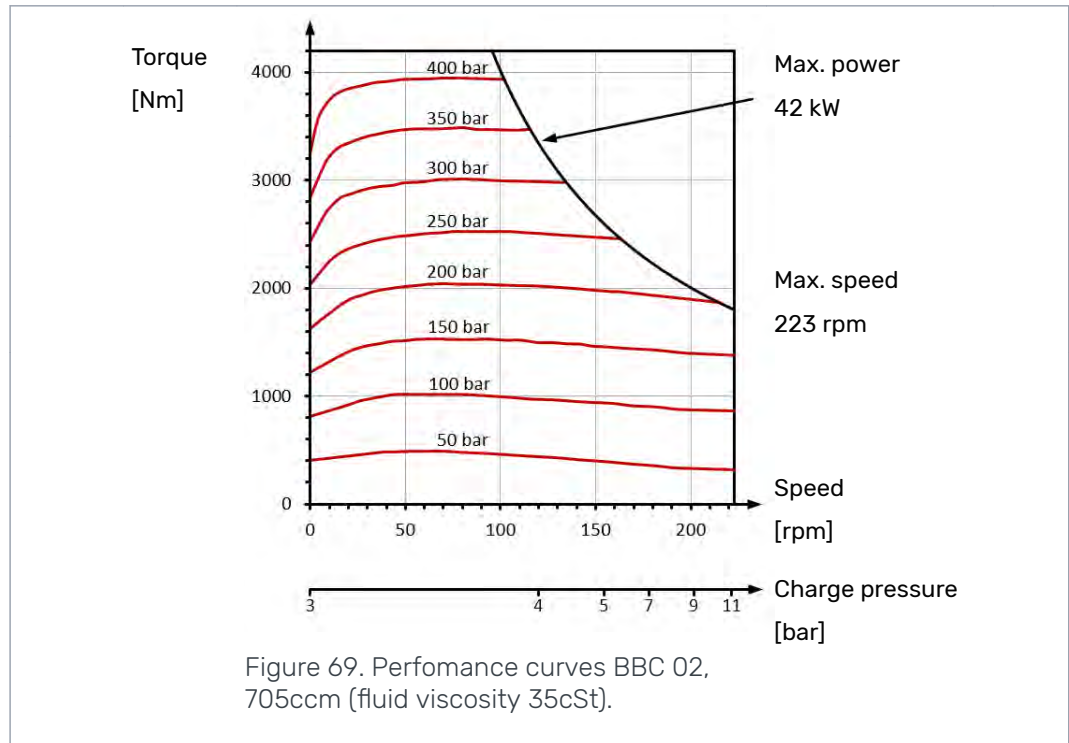

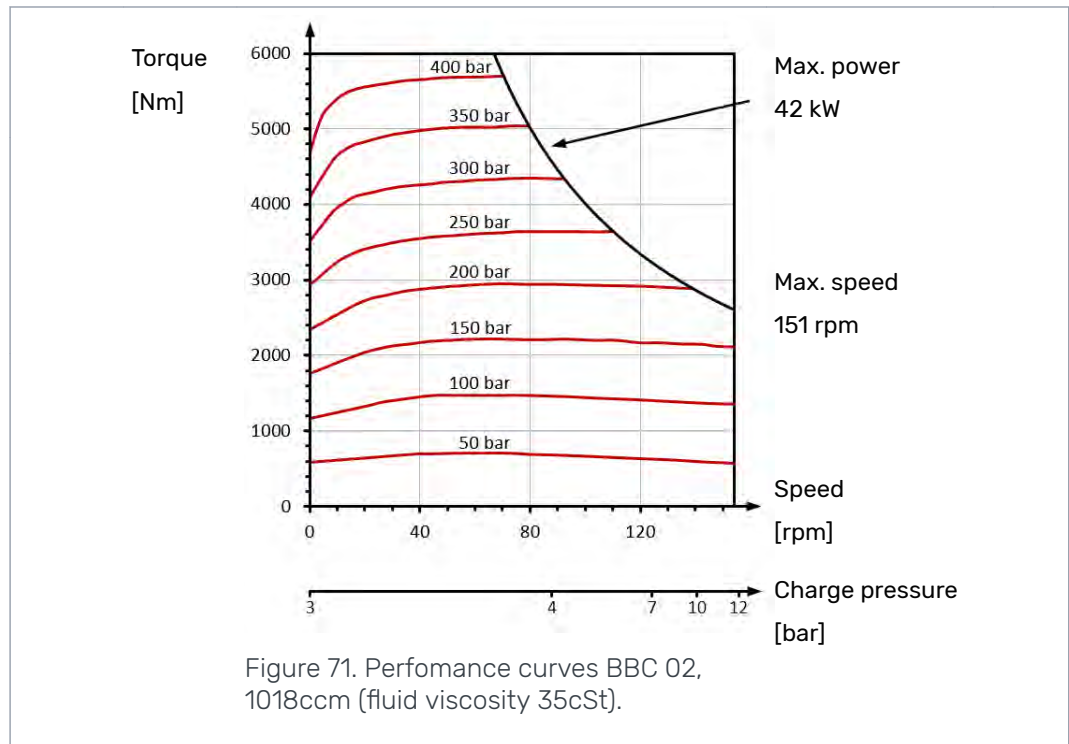

BBC 03

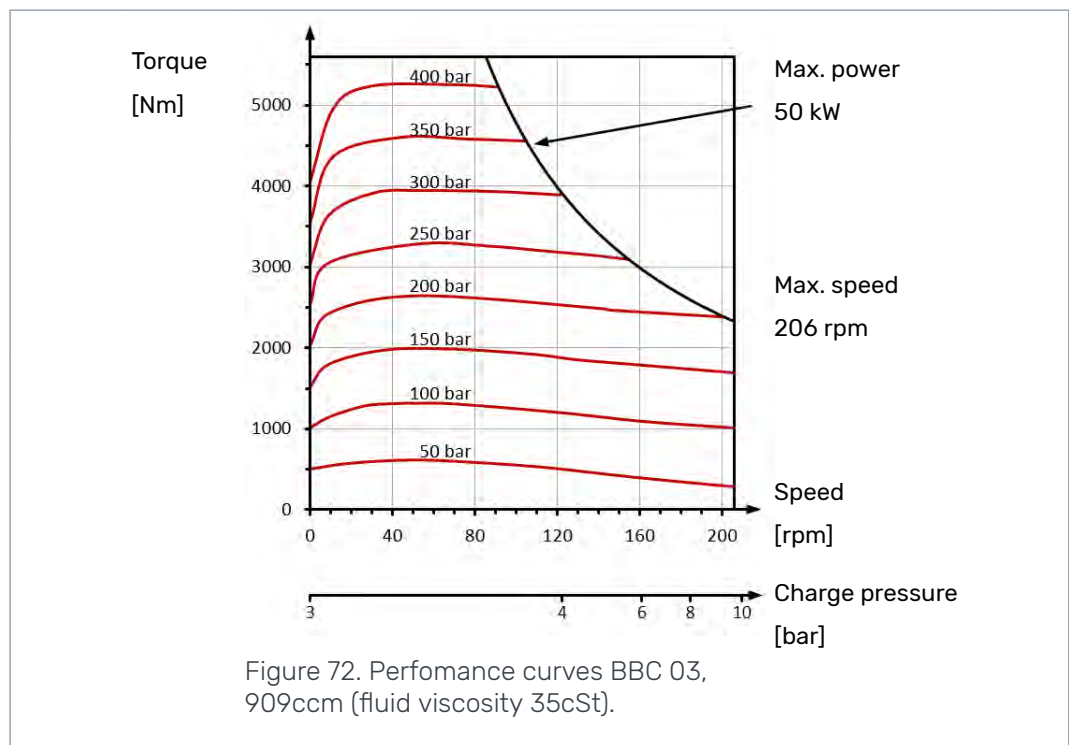

Motor Sizing

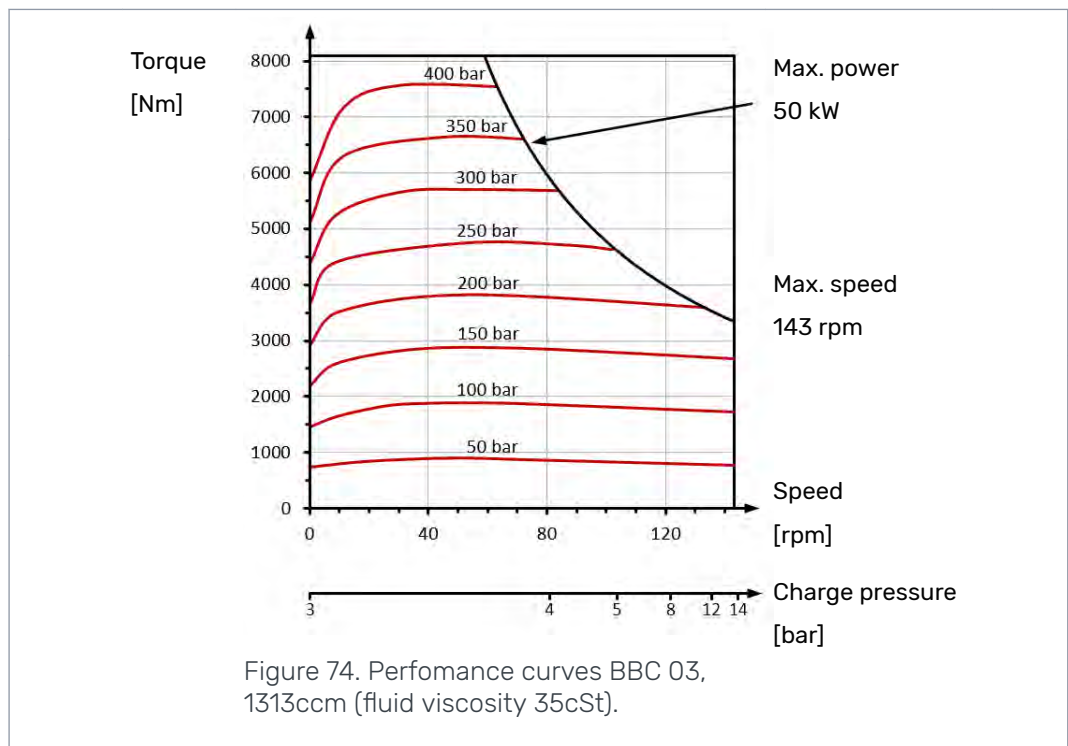
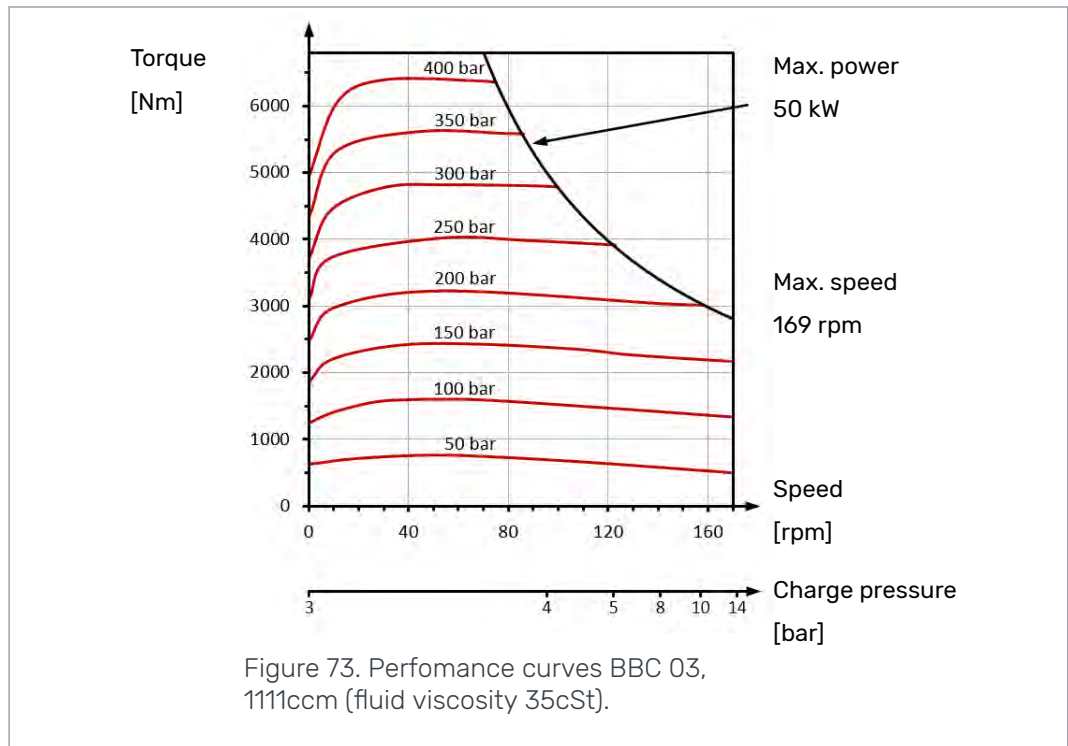

BBC 05

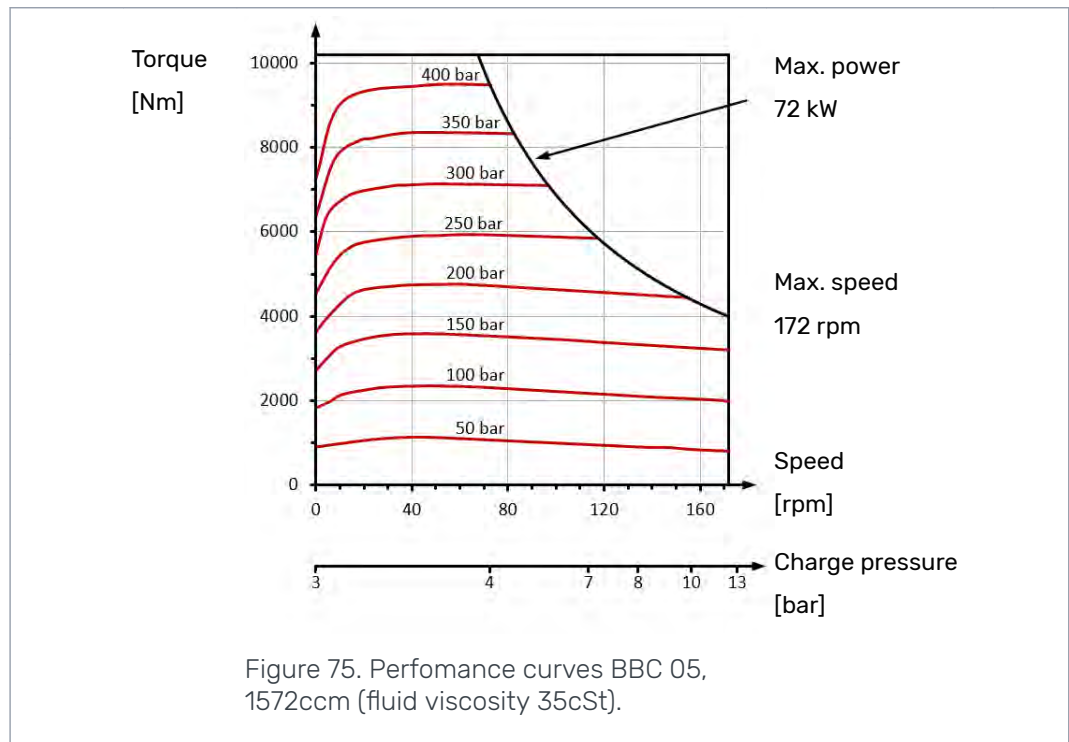

Figure 75. Performance curves BBC 05, 1572ccm (fluid viscosity 35cSt).

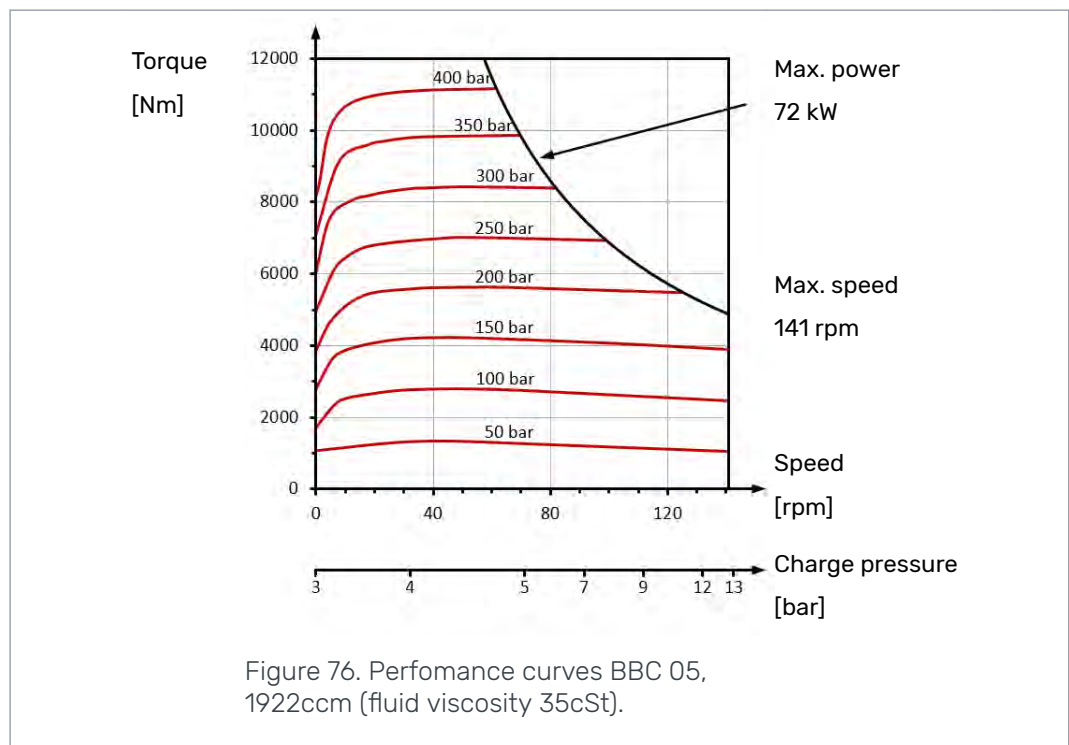
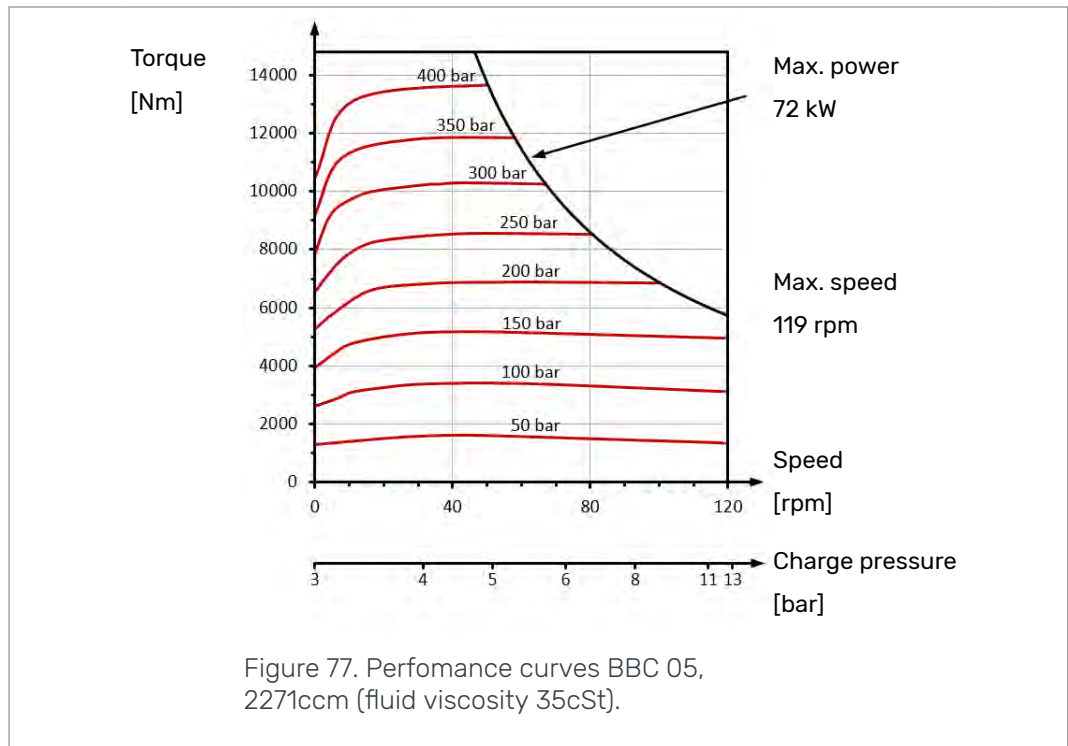
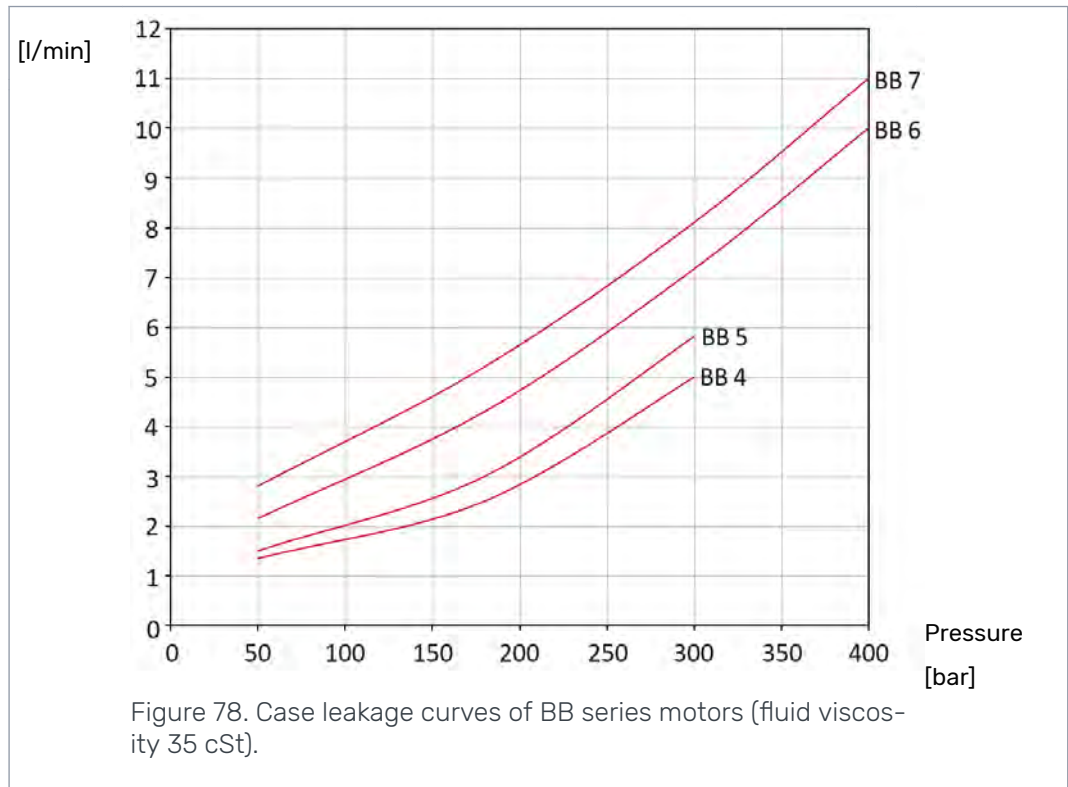

Figure 76. Performance curves BBC 05, 1922ccm (fluid viscosity 35cSt).



5.3.3

BB motors case leakage



5.3.4 BBC motors case leakage

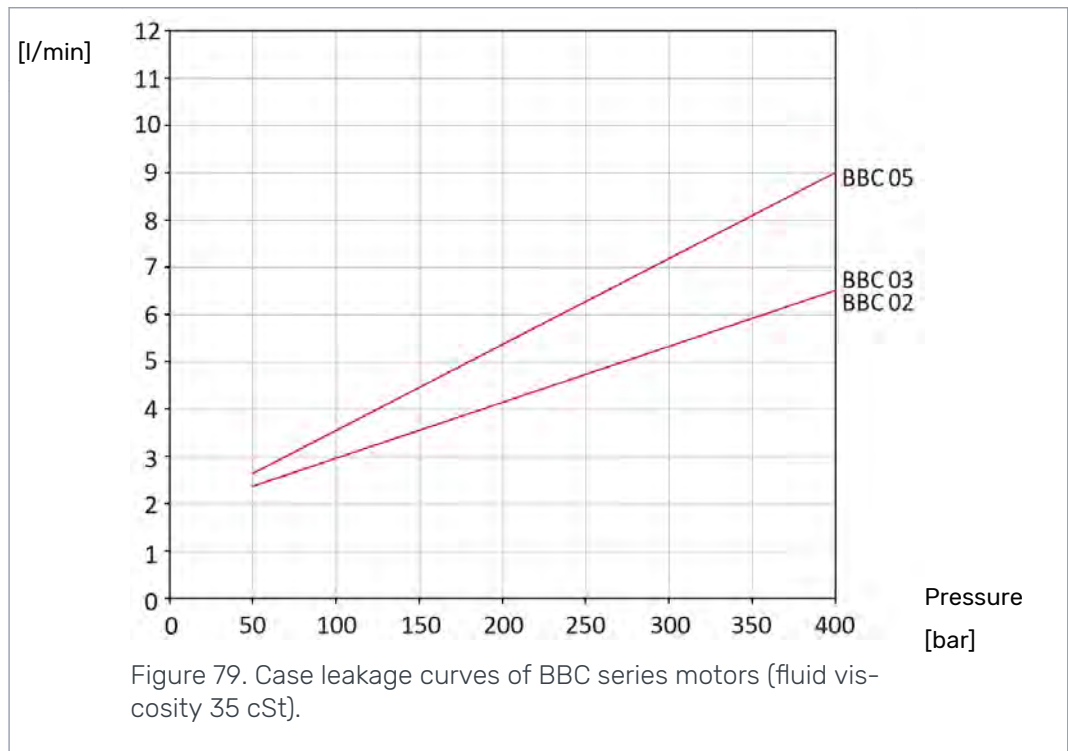

6 Installation Instructions

6.1 Conditions of installation and application

An Application Data Sheet (ADS) is used to select the correct Black Bruin hydraulic motor for each application. A filled and signed ADS is required for each motor model and application to validate the motor manufacturer's warranty. Always advise the motor manufacturer or its representative, when selecting motors for exceptional circumstances, like underwater applications, use with special fluids, etc.

6.2 Mounting the motor

The installation dimensions and tightening torques are given in the product datasheet.

Check the following things for mounting the motor:

- The counter surfaces must be clean and even.
- Make sure that the strength class (grade) of the fastening screws is sufficient.
- Make sure that the fastening screws are of suitable size and length.
- The fastening screws should be cleaned and oiled lightly before installing them.
- Use threadlocker only if necessary, removing the old threadlocker may be difficult.
- Remove any old threadlocker before mounting the motor.



Note:

When replacing fastening screws with new ones, renew all of the screws.



Attention:

When using stud bolts, do not tighten the bolt. Tightening of the stud bolt is done with the nut.

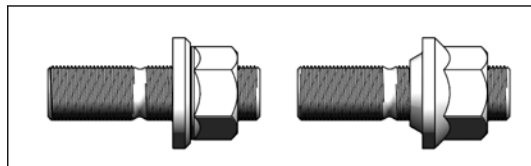

Figure 80. Stud bolt variants.

6.3 Flushing the hydraulic system

Prior to connecting the motor as part of the hydraulic system, the hydraulic circuit of the motor must always be flushed by circulating hydraulic fluid through a filter installed in place of the motor.

The flushing is carried out by circulating hydraulic fluid through the entire system with a minimum pressure for at least an hour.

- After flushing, renew all filters.



Note:

Flushing the hydraulic system should also be performed after every system modification or repair.

6.4 Hydraulic connections



Warning:

Do not apply the working pressure to the case drain line port (C, C1 or C2). This can break the motor.

Before you make any hydraulic connections to the motor, examine the motor product datasheet for the correct hydraulic connections.

6.5 Air bleeding procedure

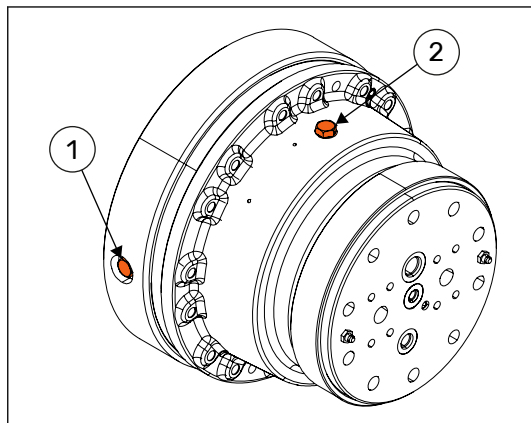

Air bleeding procedure is carried out to fill the motor case completely with hydraulic fluid. Air is removed from the motor case with the air bleed screws as follows:

- Locate the air bleed screws on the hub cover (1) or rear cover (2). Turn the motor to a position in which the bleed screw is at its topmost position.
- Make sure the drain line of the motor is connected.
- Feed hydraulic fluid into the motor with low pressure throughout the procedure (with system charge pressure or flow through the case drain line).
- Unscrew the air bleed screw by half a turn and wait for the air to bleed out.
- Close the screw when only hydraulic fluid is pouring through it.



Note:

If charge pressure is not available (open loop) or return flow through drain line is prevented, fill the case manually by pouring oil in through the bleed screw hole.

6.6 Commissioning procedure

Ensure that the following things are in order before starting a new or replaced motor:

- The hydraulic circuit of the motor is flushed.
- Motor is installed appropriately.
- Air bleeding procedure is carried out.
- The reservoir of the hydraulic system is full.

During the initial stages of use, also take the following things into consideration:

- At the initial startup, start the motor without a load.
- Do not run the motor immediately with full power. Increase the load and speed of rotation gradually.

Installation Instructions

- Observe the motor and the hydraulic system for external leaks or abnormal noises during the commissioning procedure.
- Start the motor break-in. Refer to *Break-in period* on page 67.



Attention:

Do not start the motor, if the air bleeding procedure has not been carried out.

Stressing an unused motor with full power may cause premature wear or failure of the motor.



Note:

During all installation and service procedures, plug any open ports and hoses.

When filling the reservoir, add hydraulic fluid through a filter.

6.7

Tightening torques

SCREW / HARDNESS	HUB COVER, f10.9 (Nm)	SHAFT FLANGE, f12.9 (Nm)
M12	110	135
M14	180	215
M16	275	330
M18	383	460
M20	540	650
M22	728	874

The tightening torques are valid for standard and fine thread.



Note:

The maximum torque can be limited at lower value by the motor attachment.

7 Operating Instructions

7.1 Break-in period

The motor achieves its final properties during the first hours of use. Therefore all new and reconditioned motors should go through an initial break-in period.

Things to be considered during break-in period:

- The break-in period should last for at least the first eight hours (8 h) of use.
- Operate the motors at average of 50% of rated speed and pressure.
- Limit the power output by limiting the working pressure, the speed of rotation or both.
- Do not exceed 75% of the maximum pressure for more than two seconds every minute.



Note:

During the break-in period, the moving parts of the motor wear against each other so that the wear of the parts sets to a stable state for the entire service life of the motor.

7.2 Use

Things to be considered during use of motors:

- Check the screw connections tightening torque and hydraulic connections regularly.
- Do not use pressure cleaning directly between the shaft flange and housing of the motor (the shaft seal area).
- Avoid situations in which the motors are completely submerged in water or mud.

7.3 Operating temperature

The operating temperature means the internal temperature of the motor. Take into considerations the following requirements for the operating temperature:

- For improved service life, avoid over 70 °C (158 °F) operating temperature.
- The highest permissible intermittent operating temperature is 85 °C (185 °F).
- The lowest permissible operating temperature is -35 °C (-31 °F).
- The temperature difference between the motor and the hydraulic fluid should be under 60 °C (140 °F).

The operating temperature may be measured from the hydraulic fluid returning from the motor. Take into account the temperature of hydraulic fluid returning from the drain line and from the return line (A or B).

7.4 Demounting the motor

Take into consideration the following things when demounting the motor for service or replacement:

- Release the pressure in the hydraulic lines and let the motor cool down.
- Disconnect all the hydraulic lines from the motor and plug all openings and hoses.
- Demount the motor and lift it away from its position.
- Clean the outside of the motor thoroughly, but do not use any solvents.

Operating Instructions

- Protect the cleaned motor from corrosion.
- If possible, drain all the hydraulic fluid from the motor.



Note:

Dispose of hydraulic fluid should be done appropriately.

8 Special Instructions

8.1 Storing the motor

During short term storage of the motor, the following should be taken into consideration:

- Cover any pressure openings and open threaded holes with suitable caps.
- Protect the unpainted surfaces from dirt and moisture.
- Store the motor in a dry place with relatively stable temperature.
- The motor should not be stored in a same place as substances with aggressive corrosive nature (solvents, acids, alkalis and salts).
- The motor should not be exposed to strong magnetic fields.
- The motor should not be exposed to strong vibration.



Note:

For long-term storage (over 9 months) the following additional actions are recommended:

- Damages to surface paint must be repaired.
- Protect the unpainted surfaces with suitable anti-corrosion treatment.
- Fill the motor completely with hydraulic fluid.

If these instructions are followed, the motor may be stored for approximately two years. However, as storage conditions do have a significant effect, these times should only be considered as guide values.

No POWER like it.

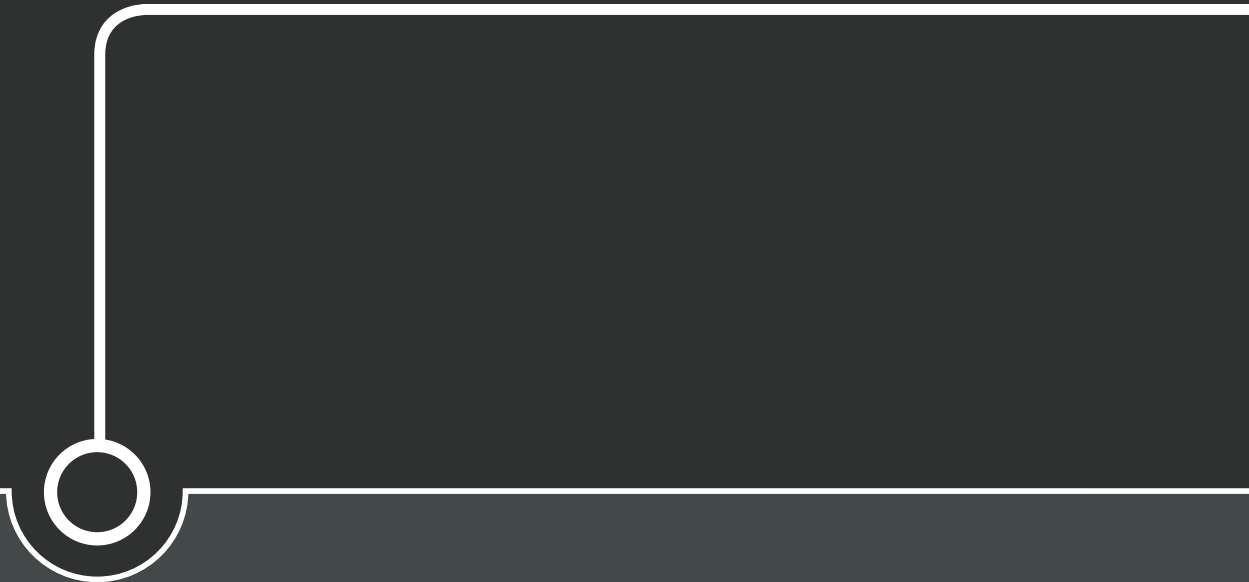

Black Bruin Inc.

+358 20 755 0755
P.O. Box 633, FI-40101 JYVÄSKYLÄ, FINLAND

www.blackbruin.com
info@blackbruin.com

All the information contained in this publication is based on the latest information available at the time of publication. Black Bruin Inc. reserves the right to make changes without prior notice.