

POWER TEAM[®]

HYDRAULIC PUMPS • CYLINDERS • JACKS • PULLERS • TOOLS



Professional Grade High Force
Hydraulic Products, Systems and Tools

PT0910 Full Line Catalog

SPX[®]

HYDRAULIC TECHNOLOGIES



ABOUT POWER TEAM

Tough Products for Tough Applications

Hydraulic Pumps

- Predator Portable Electric and Air Powered
- Electric, Air, and Gas Powered
- Hand Pumps
- Valves, hoses and accessories

Hydraulic Cylinders

- Rams
- Standard
- Construction
- Industrial
- High Tonnage
- Pancake
- Aluminum
- Pulling

Jacks

- Lifting Jacks
- Inflatable Jacks
- Post-Tensioning Jacks

Tools

- Predator Torque Wrenches
- Hydraulic Presses
- Flange Spreaders
- Nut Splitters
- Gear Pushers/Pullers
- Bearing Maintenance Pushers/Pullers

Shop Equipment

- Shop Presses
- Floor Cranes
- Load Rotors

Power Team. Over 85 years experience in supplying Professional Grade high-pressure Hydraulic Pumps, Cylinders, Jacks, Pullers & Tools.

A Heritage of Innovation

Since 1924, we've been instrumental in the development of innovative high force hydraulic power products, systems and tools. And many of our products are known as the industry standard for rugged construction, reliability, and long service life. Today, we provide a full range of professional grade products and services around the globe.

Power Team Quality

Power Team Products are built tough with strict ISO 9000 manufacturing processes and are covered by a Lifetime Marathon Warranty*.

Global Distribution and Service

Wherever your job is in the world, the Power Team network of distributors and service centers assures local product, parts and service availability.

*See Warranty page for coverage details.

POWER TEAM®

PROFESSIONAL
HYDRAULIC PUMPS,
CYLINDERS, JACKS,
PULLERS & TOOLS



CYLINDERS
6-39



PUMPS
40-103



**HYDRAULIC
ACCESSORIES**
104-133



**SHOP
EQUIPMENT**
134-147



JACKS
148-163



**HYDRAULIC
& MECHANICAL
TOOLS**
164-189



PULLERS
190-226



**MEASUREMENTS &
SPECIFICATIONS**
227-233



NUMERIC INDEX

BB1600.....181	PG1203-CP.....93, 96-97	SPM1010.....137	215315.....205	350320-350334.....36	9105A.....155
BC212 - BC212EUR...69	PG1200M-4 -	SPM256.....138	216209.....130	350376.....35	9112A -
BP12INT.....69	PG1204S.....96-97	SPM256C.....136	21669 - 21873.....39	350431.....132	9130A.....150-151
C51C - C10010C.....15	PG4004,	SPM2514.....138	22041-22044.....186	350549, 350550.....178	9015B - 9110B.....150
C55CBT -	PG4004S.....96-97	SPM556,	22185.....203	350593-350594.....222	9205A - 9220A.....155
C2514CBT.....16	PH53C,	SPM5513.....139	22274, 22275.....39	350637.....222	9190.....114
CB30 - CB100.....38	PH53CR.....212	SPM10010.....140	24196, 24197.....39	350722.....49	9500, 9501.....125
CBS60.....161	PH63C - PH113C.....210	SS2.....202	24813, 24814.....36	350723-350724.....34	9502.....124
CBS55 - CBS150.....162	PH103C, PH103CR.....212	TBP1622.....144	24835, 24836.....200	350822, 350823.....178	9504.....123
CC5 - CC25.....180	PH172 - PH503.....213	TPP1-TPP200.....144	25017.....130	350895-350898.....35	9506, 9507.....125
DG100, DG100B.....125	PH553C -	TPS6.....144	250175.....132	350984.....36	9508, 9509.....115
FC2200 - FC4400.....146	PH553CL13.....222	TWSD1-TWSD25.....166	250341-250343.....159	351075.....23	9510.....131
FK59 - FK159B.....48	PH1002 - PH1002J.....222	TWD1-063-	250353.....159	351106.....23	9511.....125
HFS3A - HFS6A.....178	PHP Series.....221	TWD25-275.....167	250459.....183	351324, 351325.....36	9512, 9513.....128
HB443, HB444.....98	PLA6014 -	TWS Series.....167	250682.....159	351334.....36	9514.....115
HNS150 - HNS225.....177	PLE6014K.....161	TWLC Series.....168-169	251002.....222	351574 - 351576.....35	9515.....131
HP20 - HP35SP.....182-183	PMA, PUA.....64-65		251468.....222	351927 - 351931.....161	9516.....128
HS2000 - HS3000.....179	PMA55 - PME55S.....163	0100 - 0600.....187	251646, 251647.....209	351953, 351954.....161	9517.....123
HST11.....211	PPH17 -	1020 - 1050.....195-197	251660.....130	351985.....177	9519.....128
HST11S.....210	PPH50R.....214	1057 - 1060.....212	251970-251999.....183	36161.....229	9520.....124
HT50A - HT200.....184	PQ603 -	1062.....214	252000.....183	36469.....144	9521.....131
HTS50.....188	PQ1204S.....86-89	1064, 1066.....213	252001-252002.....183	36578.....202, 205	9522, 9523.....128
IM10E, IM10H.....156	PR102 - PR104.....68-69	1070.....215	252215.....39	37045.....185	9524.....115
IJ13 - IJ7320.....158-159	PR2100J Thru	1074.....213	252511, 252512.....132	37368.....144	9525, 9526.....117
IPS10B,	PR3100S.....224-225	1076.....215	252542 - 253391.....157	38597.....144	9531.....131
IPS10HB.....205	R552C - R56510C.....26	1080.....213	25388 - 25750.....34-35	38855, 38904.....39	9532.....127
IPS10M,	R1002D - R56510D.....28	10461.....130	25931.....36	38908, 38909.....35	9533.....128
IPS17M.....208	R552L - R56510L.....32	10494.....132	26068 - 26666.....186	38953.....144	9534.....115
IPS17 - IPS17H.....216	RA202 - RA1006.....17	1100 - 1111.....199	27198.....36	38954.....144	9555, 9556, 9559.....115
IPS30H.....217	RA556L, RA1006L.....30	1120.....187	27241.....202	39811.....188	9560.....70
IPS3017-IPS3017B.....218	RB8013S -	1121 - 1124.....201	27287.....186	41331.....202	9561-9563.....69
IPSS017 - IPSS017B.....218	RB20013S.....142	1125.....187	27315.....202	420059 - 420064.....35	9569, 9570, 9572.....127
IPSS317.....220	RC5.....133	1126-1128.....201	27487-27555.....226	420496BK2.....39	9575.....115
J24T - J259T.....152-153	RC12V.....69	1130.....201	27737.....186	420496OR9 -	9576.....124
JAM10033 -	RC7402C-RC122010C.....27	1131.....187	27793 - 27797.....226	420498OR9.....39	9579.....127
JEM15026.....163	RC7402D-RC122010D29	1150 - 1154.....200	27876, 27877.....103	420655OR9.....39	9580, 9581.....115
K82, K83.....211	RC0552P-RC6202P.....31	1155 - 1158.....203	28228-28229.....136	420866-420871.....36	9582, 9584.....123
LR2000 - LR6000.....147	RC7402L.....70-71	1165, 1166.....200	28230.....36	421056, 421057.....23	9589, 9590.....128
MB5 - MB16.....209	RC122010.....33	1170, 1171.....203	28250 - 28256.....202	421312OR9.....39	9592.....127
P12 - P59F.....46-47	RC0552P-RC6202P.....31	1172 - 1178.....203	28323GY8.....202	43562, 43563.....144	9593.....115
P19, P59.....47	RC7402L-RC122010L33	1180 - 1182.....204	28612 - 28644.....39	44148, 44195.....202, 205	9594.....127
P157 - P460D.....48	RD106 - RD50013.....25	1188.....211	28984, 28985.....186	44457, 44458.....144	9595.....115
PA6 - PA6DM-2.....50-53	RD106 - RD50013.....25	1266.....189	29595.....36	44745, 44766.....223	9596, 9597.....115
PA7.....206	RH102 -	1320 - 1349.....187	302482, 302483.....36	45329.....188	9599, 9605.....126
PA9, PA9H.....54-55	RH2008.....20	13449.....186	303045.....223	45589.....38	9608.....115
PA50 - PA50RM.....58-59	RH306D.....21	15235.....159	303785.....36	46070.....144	9609.....126
PA60, PA64.....56-57	RHA306.....20	15702.....187	304718.....130	47997.....212	9610, 9610A.....123
PA172 - PA554.....60-63	RHA604D.....21	16339.....132	307159.....159	518, 522.....206	9615.....128
PB1230C -	RH121T.....20	16954.....186	307281.....185	58943 - 58945.....162	9616.....112
PB51156C.....209	RLS50 - RLS1500S.....18	17627.....130	308022.....177	60846.....136	9617.....113
PC200, PC200RC.....133	RP20 - RP104.....133	1890-1893.....144	308435OR9 Thru	66053 - 66055.....161	9620.....131
PCHA Series.....170	RP25, RP55.....23	201362 - 201412.....229	308440OR9.....216-220	679, 680.....201	9623.....115
PD313 - PD812.....183	RP555 - RP5556A.....49	201454, 201923.....36	308840.....177	7053K.....187	9625.....131
PE-NUT.....92	RSS101 - RSS2503.....19	202178 - 202180.....34	309652, 309653.....130	7103.....188	9626, 9627.....129
PE102 -	RT172 - RT1004.....22	202777, 202778.....130	309874-309875.....221	7123K, 7125K.....187	9628.....129
PE104.....68	RV21278 -	202817.....188	3-3932-3-3959.....107	7136.....203	9631.....115
PE120M.....100	RV21278-90.....117	203003 - 203156.....186	31772, 31776.....34-35	714.....187	9632.....129
PE172 - PE174M.....70-71	RWP55.....176	203225.....130	32054.....202	7162-7168.....189	9633.....115
PE18.....72-73	SF50.....139, 142	203264.....185	32118.....36	7180.....226	9634, 9635.....113
PE182 -	SF150.....140-142	204666.....188	32325.....34-35	7300, 7301.....187	9636-9640.....112
PE184C.....72-73	SJ2010 - SJ3010P.....157	204928.....189	32698 - 33439.....36	7307-7309.....189	9641.....131
PE213 - PE214S.....74-75	SP1010A.....137	204990.....185	3344.....188	7312.....188	9642.....113
PE302 -	SPA10 - SPA200.....145	206753.....186	33856-33865.....202	7313.....187	9643.....131
PE304R-2.....78-79	SPA256, SPA2514.....138	206767.....132	34136.....36	7392, 7393.....206	9644.....113
PE307WP.....174	SPA556.....139	207395.....144	34251.....39	7395.....188	9645-9647.....112
PE55TWP-	SPE1010,	207762.....132	34331.....202	7400, 7401.....189	9648.....112
PE55TWP4.....175	SPE1010D.....137	208380-208382.....35	34510, 34511.....36	7402.....188	9670-9690.....114
PE462 - PE464S.....80-81	SPE256.....139, 142	208401, 208402.....186	34698.....202	7406K.....187	9691.....113
PE552 - PE554T.....82-85	SPE2514DS.....138	208406.....39	34755, 34756.....36	7420, 7421.....189	9692 - 9705.....114
PE604T -	SPE556 -	208627.....202	34758.....36	8000 - 8076.....206-207	9720, 9721.....115
PE604PT.....84-85	SPE5513DS.....139	209199, 209200.....189	34806 - 34807.....145	8110 - 8148.....206	9733-9783.....106
PE4004,	SPE10010 -	209201.....187	34808.....145	885.....189	9758, 9763.....106
PE4004S.....90-91	SPE10013DS.....140	209593.....130	350090.....159	927 - 939.....199	9765-9775.....106, 107
PED253 -	SPE10010R.....140	212377.....226	350094-350100.....34	9002A -	9785-9788.....185
PED254S.....76-77	SPE15013DS -	21332.....145	350144, 350145.....35	9050A.....150-151	9792 - 9800.....108
PG120HM.....96-97	SPE20013DS.....141	213895, 213896.....133	350184.....34	9040 - 9091.....111	981.....202
PG303 - PG554.....94-95	SPH1010.....137		350207-350209.....159	9006X - 9015X.....154	

ALPHABETICAL INDEX

A	
Adapters, Step Plate.....	207
Adapters, Threaded (Puller).....	206-207
Air/Hydraulic Pumps.....	50-67
Aluminum Cylinders.....	17, 22, 23, 30, 32
Assemble to Order™	
Pumps.....	100-103
Attachments, Pulling.....	200-201
Axle Journal Roller Bearing Service Equipment.....	224
B	
Bead Breaker.....	181
Bearing Cup Installer.....	224-225
Bearing Cup Remover.....	203
Bearing Pulling Attachments.....	200-201
Bench Presses.....	137
Blankets, Protective.....	209
Blind Hole Puller Set.....	202
Bushing and Bearing Drivers.....	226
C	
Casters.....	132
Center-Hole Cylinders.....	20, 21
Accessories.....	39
Center-Hole Twin Cylinders.....	24
C-Clamps.....	180
C-Frame Press.....	136
Chain Wrenches.....	189
Chaser, Thread.....	188
Counter-balance Valve.....	118
Couplers, Hydraulic.....	108, 114
Crane Accessories.....	147
Cranes, Mobile.....	146
Cribbing Block Sets.....	38, 160-162
Cylinder-Pump- Hose Sets, Hydraulic.....	49
Cylinders, Hydraulic.....	12-39
D	
Digital Pressure Gauge.....	110-111
Double-Acting Cylinders	21, 22, 24, 25
E	
Electric/Hydraulic Pumps.....	68-91
“Enforcer 55” Hydraulic Puller.....	222
“Enforcer 100” Hydraulic Puller.....	223
F	
Filter/Regulator/ Lubricator, Air.....	131
Fixtures, Straightening.....	139-142
Flange Spreaders.....	178
Floor Cranes, Mobile.....	146
Flow Characteristics, Valves	48-50, 120-122

Fluid Level & Temperature Gauge.....	132
Foot Pump Conversion Kit.....	48
Forcing Presses.....	134-143
G	
Gauges, Hydraulic Pressure.....	110-111
Gear and Pulley Pullers.....	196-220
Gland Nut Wrench, Adjustable.....	189
H	
Head Inserts, Cylinder.....	39
High Pressure Air Operated Pump.....	64-65
Horseshoe Lock Ring Plier.....	187
Hose, Hydraulic.....	106
Hydra Grip-O-Matic Pullers.....	210
Hydraulic Accessories.....	104-133
Hydraulic Couplers.....	108, 114
Hydraulic Cranes.....	146
Hydraulic Cylinders.....	12-39
Hydraulic Fittings.....	114
Hydraulic Gauges.....	110-111
Hydraulic Hose.....	106-107
Hydraulic Jacks.....	148-163
Hydraulic Oil.....	112
Hydraulic Presses, Shop.....	134-147
Hyd. Puller Sets.....	216
Hydraulic Pumps.....	40-103
Hydraulic Pump- Cylinder-Hose Sets.....	49
Hydraulic Punches.....	182-183
Hydraulic Spreaders.....	178-179
Hydraulic System Testers.....	184
Hydraulic Tester Accessories.....	185
Hydraulic Tools.....	164-185
Hydraulic Valves..... Pump Mounted.....	50-57
In-Line.....	118-119
Remote.....	115-117
I	
Industrial Maintenance Sets.....	156
Industrial Maintenance Puller Sets.....	208-209, 216-217
In-Line Valves.....	118-119
Inflatable Jacks.....	158-159
Intensifier, Hydraulic.....	98
Internal Pulling Attachments.....	200
J	
Jack Modules.....	162-163
Jack Screw Attachments.....	160
Jacks, High-Tonnage.....	160-163
Jacks, Hydraulic.....	148-163
Jacks, Hydraulic Toe.....	152-153
Jacks, Inflatable.....	158-159
Jacks, Stressing.....	157
Jimmy Bars.....	189
L	
Lightweight Handpump.....	47
Load-Lowering Valve.....	118
Load-Positioning Slings.....	147
Low Profile Cylinders.....	18
Low Clearance.....	168

M	
Magnetic Pick-Up Tool.....	188
Magnetic Strip.....	132
Maintenance Sets.....	156
Manifolds.....	113
Metering Valve.....	119
Metric Conversion Charts.....	230
Mini Jack.....	155
N	
Nut Splitters.....	177
O	
Oil, Hydraulic.....	112
“O” Ring Seal Pick.....	188
P	
Pancake Cylinders.....	31
Photo Tachometer, Digital.....	188
Pipe Flange Spreaders.....	178
Pliers, Retaining Ring.....	187
Positioning Slings.....	147
Post Tensioning Valves.....	129
Press Accessories.....	144-145
Presses, Hydraulic Roll-Bed.....	142-143
Presses, Hydraulic Shop.....	134-143
Pressure Gauges, Hydraulic.....	110-111
Pressure Switches.....	131
Protective Blankets.....	209
Pry Bars.....	189
Puller Adapters.....	206-207
Puller Attachments.....	200-201
Puller, Blind Hole.....	202
Pullers, Bearing.....	196-226
Pullers, Bearing Cup.....	203
Pullers, Gear.....	196-220
Pullers, Hydraulic.....	210-226
Pullers, Internal.....	200-205
Pullers, Jaw-Type	196-197, 208-209, 216-220
Pullers, Pulley.....	201
Pullers, Sets.....	204-205, 208
Pullers, Slide Hammer.....	202-203
Pulley Pullers.....	201
Pull Cylinders.....	25
Pump Cart.....	133
Pump Accessories, Hydraulic.....	130-133
Pump-Cylinder-Hose Sets, Hydraulic.....	49
Pump Mounted Valves.....	123-129
Pump Reservoirs.....	133
Pumps, Hydraulic.....	103
Pumps, Hydraulic, Air.....	50-67
Pumps, Hydraulic, Electric.....	68-91
Pumps, Hydraulic, Gas.....	93-97
Pumps, Hydraulic, Hand.....	46-49
Pumps, Torque Wrench.....	170-176
Punches, Hydraulic.....	181-182
Push-Pullers, Hydraulic.....	221
Push-Pullers, Mechanical.....	214-215
Q	
Quality Standards, Industry.....	231
Quarter Horse Pumps.....	68-69
“Quiet” Pumps.....	86-89

R	
Railroad Axle Journal Bearing Service Equipment.....	224-225
Ratcheting Chain Wrenches.....	189
Remote Controls.....	130
Remote Mounted Valves.....	116-117
Reservoir Breather Kit.....	132
Retaining Ring Pliers.....	187
Rethreading Tools.....	188
Roll-Bed® Presses.....	142-143
S	
Safety Seminars.....	235
Shaft Protectors.....	207
Shop PressAccessories.....	144-145
Shop Presses.....	134-143
Shorty Cylinders.....	21
Slide Hammer Pullers.....	202-203
Slings, Load-Positioning.....	147
Solenoid-Operated Valves.....	127-128
Spanner Wrenches.....	189
Spreaders, Hydraulic.....	178-179
Square Drive.....	166-167
Standards, Quality.....	231
Step Plate Adapters.....	207
Storage Boxes, Puller Sets.....	204-205
Straightening Fixtures.....	139-140, 142
Straightening Tool.....	211
Stressing Jacks and Pumps.....	84-85, 157
“Strong Box” Puller Sets.....	205
Subplates, Pump.....	131
Switches, Hand and Foot.....	130-131
T	
Testers, Hydraulic System.....	184-185
Temperature & Fluid Level Gauge.....	132
Thread Chaser.....	188
Threaded Adapters, Puller.....	206-207
Tire Pressing Set.....	144
Toe Jacks, Hydraulic.....	152-153
Tools, Hydraulic.....	164-185
Torque Wrench Pumps.....	170-176
Torque Wrench.....	166-169
Torque Wrench Links.....	168
Torque Wrench Sockets.....	167
Torque Wrench, Low Clearance.....	168
Torque Wrench Reducers.....	169
V	
V-Belt Pulley Pulling Attachments.....	201
Valves, Hydraulic Pump Mounted.....	122-129
In-Line.....	118-119
Viton Seal Kits.....	37
W	
Warranty.....	233
Wrenches, Industrial.....	189
Wrenches, Ratcheting Chain.....	189
Wrenches, Spanner.....	189
Wrenches, Torque.....	166-169

PUMP CAPACITY

Selection Chart

Choose the Right Pump
Choose the Right Tonnage,
stroke and retracted height

The Following guidelines are for general lifting and construction applications. Hydraulic tools, pullers and presses may fall outside these

recommendations. Always check to see that the pump's "usable reservoir capacity" exceeds the cylinder(s) oil Capacity.

Generally Recommended



Marginal Check Requirements



Not Recommended for most applications



10,000 psi Maximum Working Pressure

	PUMP MODEL	STROKE	CYLINDER CAPACITY (Tons)																			
			PRESSURE STAGE																			
			5	10	15	20	25	30	55	75	100	150	200	300	400	500						
	46	P12‡	Single	14	32	44	65	72	93													
	46	P55‡	Single	6	14	19	28	31	40	71												
	47	P19/ P19L	Low	4	8	10	15	17	21													
			High	13	30	42	59	68	86													
	47	P59F	Low	1.8	4.1	5.7	8	9	12	20	29											
			High	8	17	24	34	48	50	85	122											
	47	P59(L)‡	Low	1.5	3.2	4.7	7	7.7	9.7	16.7	23.9											
	48	P157‡	High	6	14	19	28	31	40	71	101											
	48	P159‡	Low	0.5	1	1.3	1.9	2.2	2.8	5	7	9	13	18								
	48	P300‡	High	7	15	21	30	34	43	77	110	143	200	250								
48	P460‡	Low	0.1	0.3	0.6	0.6	0.7	0.9	1.5	2.2	2.8	4.2	5.6	8.4	11.2							
		High	3.3	7.7	9	14	17.5	22	37	55	71	105	143	213	284							
	68	PE10	Low	0.5	1.2	1.6	2.2	2.6	3.2	5.5												
			High	6	13.4	18.9	27	31	39	66.2												
	70	PE17‡	Low	0.2	0.5	0.7	0.9	1.1	1.4	2.3	3.3	4.3	6.5	8.7								
			High	3.5	7.9	10.9	16	18	23	39	56.3	73	109	146								
	72-73	PE18	Low	0.4	0.8	1.2	1.6	1.8	2.3	3.9	5.7	7.3	10.8	14.6	21.9	29.2						
			High	3.3	7.5	10.3	15	17	21	37	53	69	102	136	207	276						
	74-75	PE21‡	Low	0.2	0.5	0.7	1.0	1.1	1.4	2.5	3.6	4.6	6.8	9.2	13.8	18.4						
			High	2.8	6.4	9	13	15	19	32	45.5	59	88	118	177	236						
	76-77	PED25	Low	0.2	0.4	0.6	0.9	1.0	1.3	2.2	3.2	4.1	6.1	8.3	12.0	15.7	19.9					
			High	2.4	5.4	7.5	10.6	12.4	15.6	26.5	38.2	49.5	73.6	99.1	144.3	188.5	238.6					
	78-79	PE30‡	Low	0.2	0.45	0.6	0.9	1	1.3	2.2	3.2	4.1	6									
			High	2	4.5	6	9	10	13	22	32	41	60									
	80-81	PE46‡	Low	0.1	0.3	0.4	0.5	0.6	0.7	1.3	1.8	2.4	3.5	4.7	7.2	9.6						
			High	1.3	2.9	4.1	5.9	6.8	8.6	14	22	28	42	56	84	112						
	82-83	PE55‡	Low	0.1	0.2	0.3	0.4	0.4	0.6	0.9	1.4	1.8	2.6	3.5	5.4	7.2						
84-85	PE60‡	High	1.1	2.4	3.4	4.8	5.6	7.1	12	17.8	23	34	45	69	92							
86-87	PQ60	Low	0.1	0.2	0.3	0.4	0.4	0.5	0.9	1.3	1.7	2.5	3.4	5.1	6.8	8.5						
		High	1	2.2	3.3	4.4	5.2	6.5	11	16.2	21	31	41	63	84	105						
88-89	PQ120	Low	0.1	0.2	0.3	0.4	0.4	0.5	0.9	1.3	1.7	2.5	3.4	5.1	6.8	8.5						
		High	0.5	1.1	1.6	2.2	2.6	3.2	5.5	7.7	10	15	21	30	40	50						
90-91	PE400	Low	0.1	0.1	0.2	0.2	0.3	0.3	0.6	8	1	1.5	2.1	3	4	5						
		High	0.1	0.3	0.4	0.6	0.7	0.9	1.6	2.2	2.9	4.4	5.9	8.7	11.6	14.5						
	50-51	PA6‡	Single	10	22.4	31	44.4	51.3	65.2													
	54-55	PA9‡	Single	10	22.4	31	44.4	51.3	65.2													
	60-61	PA17‡	Low	0.2	0.5	0.7	0.9	1.1	1.4	2.3	3.3	4.3	6.5	8.7								
			High	3.5	7.9	10.9	16	18	23	39	56	73	109	146								
	62-63	PA46‡	Low	0.1	0.3	0.4	0.5	0.6	0.7	1.3	2	2.4	3.5	4.7	7.2	9.6						
			High	1.3	2.9	4.1	5.9	6.8	8.6	14	22	28	56	42	84	112						
62-63	PA55‡	Low	0.1	0.3	0.4	0.6	0.7	0.9	1.5	2.2	2.8	4.1	5.5	8.4	11.2							
		High	1.1	2.4	3.4	4.8	5.6	7.1	12	18	23	34	45	69	92							
	94-95	PG30	Low	0.3	0.7	1	1.3	1.6	2	3.3	4.8	6.2	9.3	12.4	18.1							
			High	2	4.5	6.3	8.9	10.3	13	22	31.8	41.3	61.4	83	121							
	94	PG55‡	Low	0.1	0.3	0.4	0.6	0.7	0.8	1.4	2	2.6	3.9	5.2	7.6	9.9	12.5					
			High	1.1	2.5	3.5	4.9	5.6	7.1	12.1	17.3	22.5	33.5	45	66	86	109					
	96-97	PG120‡	Low	0.1	0.3	0.4	0.6	0.7	0.8	1.4	2	2.6	3.9	5.2	7.6	9.9	12.5					
			High	0.5	1.0	1.5	2.0	2.4	3.0	5.1	7.3	9.5	14.2	19.1	27.8	36.3	46.0					
96-97	PG400	Low	0.1	0.1	0.2	0.2	0.3	0.3	0.6	0.8	1.0	1.5	2.0	3.0	3.8	4.9						
		High	0.2	0.3	0.5	0.7	0.8	1.0	1.7	2.4	3.1	4.6	6.2	9.0	11.8	15.0						

‡ Some Power Team pumps are available in special configurations not listed in this catalog. Power Team can "Assemble to order" pumps with special seals, voltages, valves, relief valve settings, etc. For your special requirements please consult your local distributor or the Power Team factory.

* Hand Pumps = Number of strokes required to move piston 1". † Air, Electric and Gasoline Engine/Hydraulic pumps = Number of seconds required to move piston 1".

CYLINDER SELECTION

Choose The
Right Cylinder

Step 1 Select the hydraulic cylinder that best suits the application.
See page 7, 12-13.

Step 2 Select the hydraulic pump, with valve option, that best matches the cylinder and application. See pages 6, 42-49, 120-121.

Step 3 Select the hydraulic accessories you need. See pages 34-39.

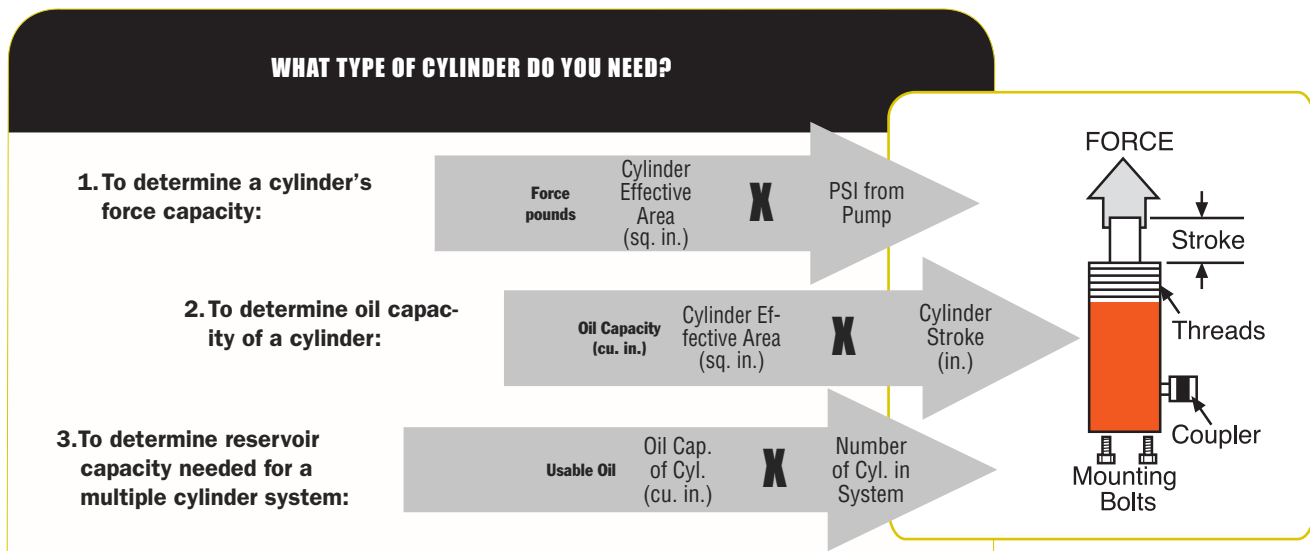

CONSIDERATIONS:

1. What push or pull tonnage is required per cylinder in your application? (Rule of thumb; Always choose a cylinder with a tonnage rating of 20% or more than what is required to lift the load.)
2. What is the push or pull stroke length required?
3. Does the cylinder need to push, pull or both? (Single-acting cylinders extend the piston under hydraulic pressure; double-acting cylinders extend and retract the piston under pressure.)
4. Does the application require multiple cylinders?
5. Is the application stationary, or must the components be light in weight for easy portability?
6. Do you need to extend a rod or cable through the center of the cylinder for the application, as in a tensioning operation?
7. Does the application require that the cylinder fit within limited-clearance work areas?
8. Does the application require that the cylinder be "dead-ended" at the end of its work stroke?
9. Will the cylinder need to withstand off-center loads? Cylinders with swivel caps are available.
10. Does the application require that the lifted load be supported for extended periods of time? Locking collars are ideal for such jobs, as are cribbing blocks.
11. Is corrosion resistance required? Our unique "Power Tech" surface treatment is standard on many Power Team cylinders, and optional on many of our cylinders which feature steel construction.
12. Will the application involve high cycles (over 2,500 in the cylinders lifetime)? Our "RD", "RH", "RP" and "C" series cylinders are ideal choices. Please refer to pages 12-13 for the capabilities of each cylinder.



ONLY POWER TEAM PROVIDES THE **POWER TECH** SURFACE TREATMENT:

- High corrosion and wear resistance, anti-galling properties.
- Significantly increases the life expectancy of a cylinder.
- Retains lubricants, prevents bronze and other materials from sticking to surface.
- Increases fatigue strength and impact strength.
- Increases surface yield and tensile strength.
- Provides improved abrasion and scratch resistance.
- Causes no appreciable dimensional change.
- 56 Rc minimum surface hardness.
- Passes ASTM B117-85 100 hour salt spray corrosion resistance tests.

The “**Power Tech**” surface treatment is standard on the gland nut, cylinder body and piston/piston rod of the following cylinders: RLS50, RLS100, RLS200, RLS300, RLS500S, RLS750S, RLS1000S, RLS1500S, and RSS1002. NOTE: Bronze plating may be used in place of the “Power Tech” surface finish for the piston/piston rod of any of the above cylinders. The “**Power Tech**” surface treatment is standard on the standpipe of all “RH” series single and double- acting cylinders. The “**Power Tech**” surface treatment is standard on the piston/piston rod of the RT172, RT302 and RT503 cylinders.

HYDRAULIC CIRCUITS

Pumps, Cylinders,
Controls

Countless applications are possible with Power Team hydraulic components. In presses, for lifting or jacking applications or in production or maintenance setups. The pump shown is a typical electric/hydraulic unit. Electric, air or gas driven pumps are available.

1 Single-acting cylinder or cylinders in the circuit, controlled by a pump mounted valve.

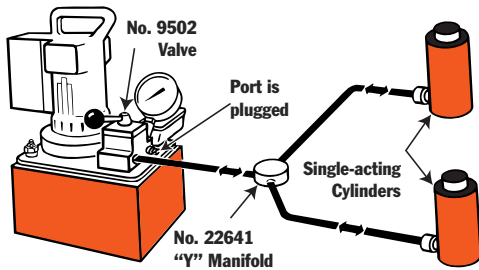

2 Double-acting cylinder or cylinders in the circuit, controlled by a pump mounted valve.

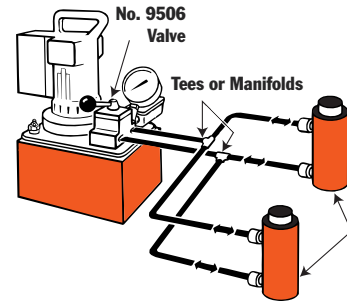

3 Single-acting cylinder controlled by a remote mounted valve.

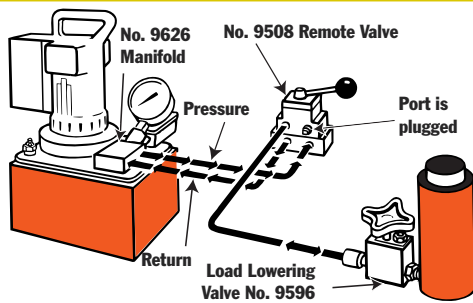

4 Double-acting cylinders controlled by a remote mounted valve.

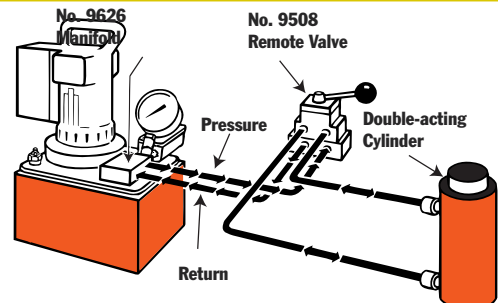

5 Single-acting cylinders with a sequence valve which controls the primary and secondary cylinder circuits.

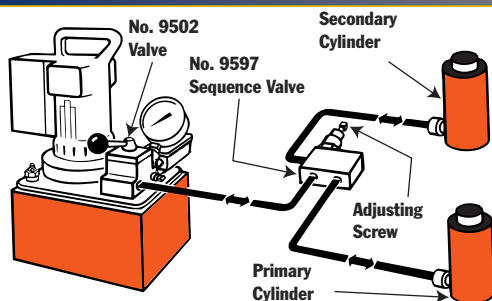

6 Double-acting cylinder with a sequence valve which controls the primary and secondary cylinder circuits.

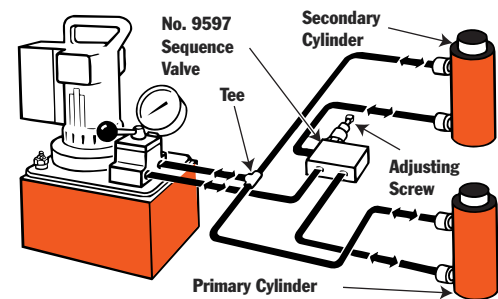

Basic single-acting system with a hand pump, gauge, hose and single-acting cylinder.

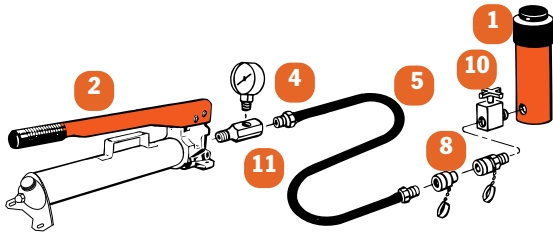

- 1 Cylinder – applies hydraulic force.
- 2 Pump – a device for converting mechanical energy to fluid energy.
- 3 Directional valve – controls the direction of hydraulic fluid in the system.
- 4 Gauge – measures P.S.I. pressure (Pounds per Square Inch) and/ or force.
- 5 Hose – transports hydraulic fluid.
- 6 Manifold – allows distribution of hydraulic fluid from one source to several cylinders. (No. 9617)
- 7 Swivel Connector – allows proper alignment of valves and/or gauges. Used when units being connected cannot be rotated. (No. 10469)
- 8 Quick Coupling – “hose half” and “cylinder half” couplings are used for quick connection and fluid flow check when separated. (No. 9797 and 9798)
- 9 Shut-Off Valve – regulates the flow of hydraulic fluid to or from cylinders. (No. 9642 or 9644)
- 10 Load-Lowering Valve – allows metered lowering of cylinder and provides safety when prolonged load holding is required. (No. 9596)
- 11 Tee Gauge Adapter – allows for installation of pressure/tonnage gauge anywhere in the hydraulic system. (No. 9670)
- 12 Pipe Plug – for blocking unused ports within the system. (No. 10909)

Basic single-acting system with a hand pump, gauge, hose, multiple shut-off valves, load-lowering valves and multiple cylinders.

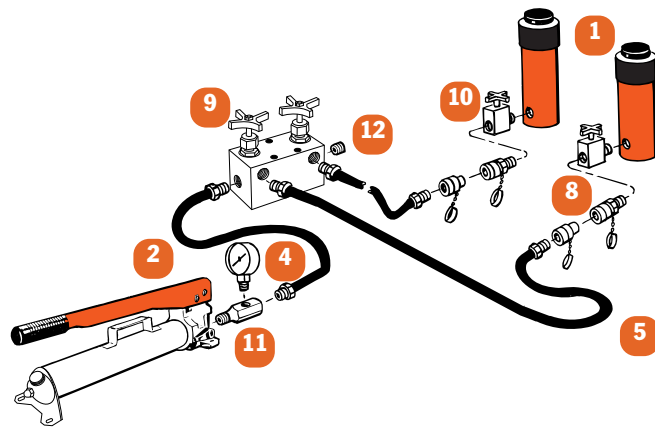

Basic double-acting system with an electric/hydraulic pump, shut-off valves, load-lowering valves and multiple double-acting cylinders.

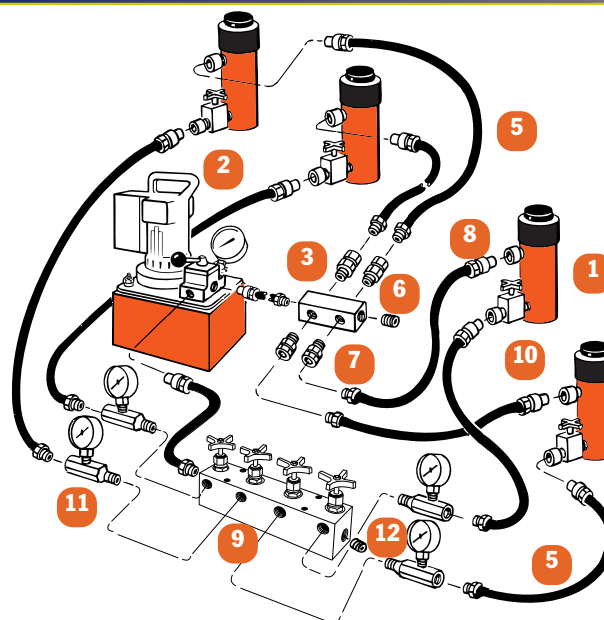

FROM
2
TO
1220
TONS!

CYLINDERS

SUPERIOR FEATURES OF POWER TEAM HYDRAULIC CYLINDERS:

We build our own cylinders in our ISO 9001 registered manufacturing facility. All Power Team cylinders are date-coded. Maximum pressure rating and capacity are stamped on the cylinder. All cylinders comply to the demanding ASME B30.1 standard and are proof tested to 125% of capacity

before leaving our factory. Cylinder bores are roller burnished to harden the surface and make it smoother, increasing seal life by 30%. Base mounting holes withstand full capacity of the cylinder. Typical cylinder burst pressures range from 25,000 to 35,000 psi. Cylinders with gland nuts may be "dead-ended" at 10,000

psi. Cylinders are assembled and tested by certified assemblers. Eddy current and mag particle inspection detects flaws in the steel. Cylinder bodies are solid steel, not welded like some competitive cylinders. Material is removed from surface to assure that any flaws are removed.



Series	Description	Page	Action	TONNAGE										
				2	5	10	12	15	17.5	20	25	30	50	
C	General Purpose	14	Single/Spring		X	X		X			X			
CBT	Threaded End Cylinders	16	Single/Spring		X	X					X			
RA	Aluminum Cylinders	17	Single/Spring							X		X		
RD	Industrial Cylinders	18	Double Acting		4	9	16				X			
RLS	Low Profile Cylinders	18	Single/Spring		X	X				X		X	X	
RSS	Shorty Cylinders	19	Single/Spring/Double Act			X				X		X	X	
RH	Center Hole Cylinders	20	Single/Spring/Double Act			X	X			X		X	X	
RT	Center Hole Power Twin Cylinders	22	Single/Spring/Double Act						X			X	X	
RP	Pull Cylinders	23	Single/Spring	X	X									
RD	Double Acting Cylinders	24	Double Acting			X					X			
R	High Tonnage Cylinder	26, 28	Single Acting/Load Return/ Double Acting											
RL	Locking Collar Cylinders	30, 32-33	Single Acting/Load Return											
RC	Pancake Cylinders	31	Single Acting/Load Return											

Page
C SERIES...14
General Purpose Cylinders



Page
CBT SERIES... 16
Threaded End Cylinders



Page
RA SERIES...17
Aluminum Cylinders



Page
RLS SERIES...18
Low Profile Cylinders



Page
RSS SERIES...19
Shorty Cylinders



Page
RH SERIES...20
Center Hole Cylinders



Page
RT SERIES...22
Center Hole Power-twin®
Cylinders



Page
RP SERIES...23
Pull Cylinders



Page
RD SERIES...24
Double-Acting,
Hydraulic-Return



Page
R SERIES...26, 28
Single Acting, Load Return
Double-Acting,
Hydraulic Return



Page
RL ALUMINUM ...30
Locking Collar Aluminum



Page
RC SERIES...31
Pancake cylinders



Page
RL STEEL...32
Locking Collar Steel



Page
ACCESSORIES ...34-39

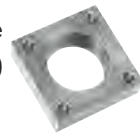

	TONNAGE													740 TO			
	55	60	75	80	100	150	200	250	280	300	355	400	430		500	565	1220
C	X		X		X												
CBT																	
RA	X				X												
RLS			X		X	X											
RSS					X			X									
RH		X			X	X	X										
RT					X												
RP																	
RD	X			X	X	X	X			X		X		X			
R	X				X	X	X		X		X		X		X	X	
RL	X†				X†	X	X		X		X		X		X	X	
RC	X				X	X		240		X					620		

† LOCKING COLLAR AVAILABLE IN ALUMINUM.

GENERAL PURPOSE

C SERIES

5-100 TONS

General Purpose, Single Acting,
Spring-Return



RUGGED, HIGH QUALITY CYLINDER USED FOR LIFTING AND PRESSING

- Aluminum bronze bearing reduces wear caused by off-center loads.
- Maximum sized springs speed piston return and increase spring life.
- Solid steel cylinder body for durability.
- Chrome plated piston rod resists wear and corrosion.
- Wide range of accessories available to thread onto piston rod, collar, or onto cylinder base.
- Base mounting holes standard on 5 through 55 ton cylinders; optional on 75 and 100 ton cylinders.
- A 3/8" NPTF female half coupler is standard.

Cylinder Tonnage	No. Holes	Thread Size	Thread Depth	Bolt Circle Diameter (In.)
5	2†	1/4-20	0.38	1.00
10		5/16-18		1.56
15		3/8-16	0.50	1.88
25		1/2-13	0.75	2.31
55				3.75
*Optional 75	4	3/4-10	1.00	4.50
*Optional 100		1-8		4.75



BASE MOUNTING HOLES

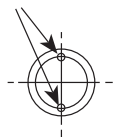

* Consult Factory (45° from coupler) † 90° from coupler.

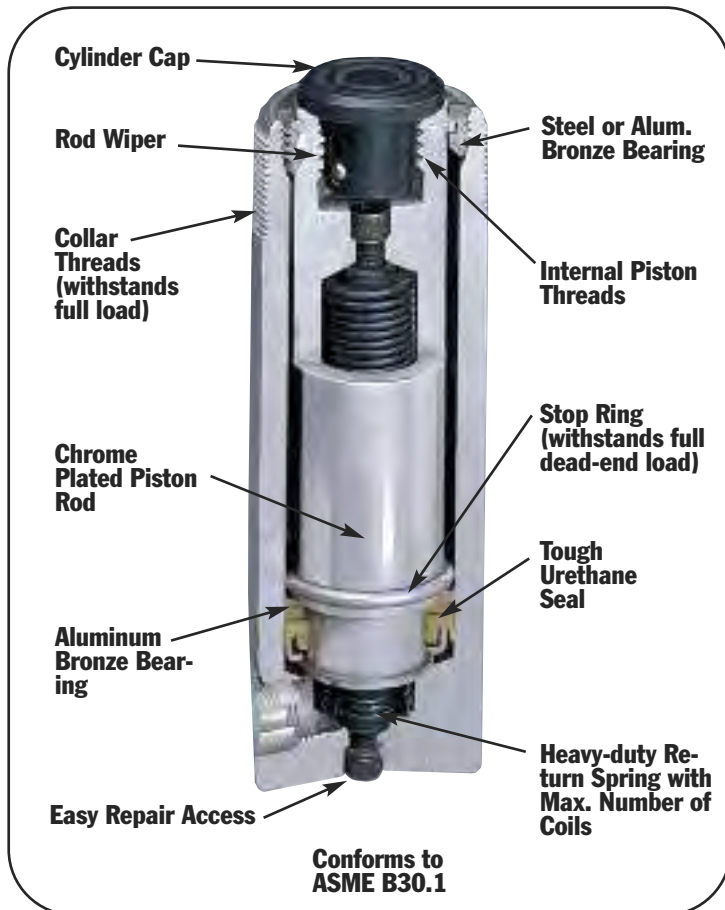

C756C

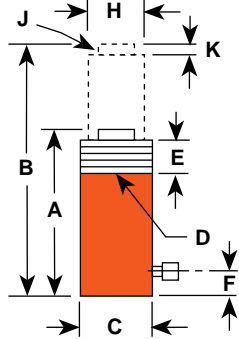

Cyl Cap Tons	Stroke (in.)	Order No.	Oil Cap. (cu. in.)	A	B	C	D	E	F	H	J	K	Bore Dia. (in.)	Cylinder Effective Area (sq. in.)	Internal Press. (psi)	Tons at 10,000 (psi)	Prod. Wt. (lbs.)
				Re-tracted Height (in.)	Ex-extended Height (in.)	Outside Dia. (in.)	Collar Thread (in.)	Piston Collar Thread Length (in.)	Base to Rod Port (in.)	Piston Rod Dia. (in.)	Piston Rod Int. Thread and Depth (in.)	Rod Protrusion (in.)					
5	1	C51C	1.1	4 ¹¹ / ₃₂	5 ⁷ / ₁₆	1 ¹ / ₂	1 ¹ / ₂ -16	1 ¹ / ₈	3/4	1	3/4-16 x 5/8	1/4	1 ¹ / ₈	.994	10,061	4.97	2.25
	3/4	C53C	3.2	6 ¹ / ₂	9 ³ / ₄	1 ¹ / ₂	1 ¹ / ₂ -16	1 ¹ / ₈	3/4	1	3/4-16 x 5/8	1/4	1 ¹ / ₈	.994	10,061	4.97	3.26
	5/4	C55C	5.2	8 ¹ / ₂	13 ³ / ₄	1 ¹ / ₂	1 ¹ / ₂ -16	1 ¹ / ₈	3/4	1	3/4-16 x 5/8	1/4	1 ¹ / ₈	.994	10,061	4.97	4
	7/4	C57C	7.2	10 ³ / ₄	18	1 ¹ / ₂	1 ¹ / ₂ -16	1 ¹ / ₈	3/4	1	3/4-16 x 5/8	1/4	1 ¹ / ₈	.994	10,061	4.97	5
	9/4	C59C	9.2	12 ³ / ₄	22	1 ¹ / ₂	1 ¹ / ₂ -16	1 ¹ / ₈	3/4	1	3/4-16 x 5/8	1/4	1 ¹ / ₈	.994	10,061	4.97	5.8
10	1	C101C	2.2	3 ⁵ / ₈	4 ⁵ / ₈	2 ¹ / ₄	2 ¹ / ₄ -14	1 ¹ / ₈	3/4	1 ¹ / ₂	1-8 x 3/4	1/4	1 ¹¹ / ₁₆	2.236	8,948	11.2	4
	2 ¹ / ₈	C102C	4.8	4 ³ / ₄	6 ⁷ / ₈	2 ¹ / ₄	2 ¹ / ₄ -14	1 ¹ / ₈	3/4	1 ¹ / ₂	1-8 x 3/4	1/4	1 ¹¹ / ₁₆	2.236	8,948	11.2	5
	4 ¹ / ₈	C104C	9.2	6 ³ / ₄	10 ⁷ / ₈	2 ¹ / ₄	2 ¹ / ₄ -14	1 ¹ / ₈	3/4	1 ¹ / ₂	1-8 x 3/4	1/4	1 ¹¹ / ₁₆	2.236	8,948	11.2	6.7
	6 ¹ / ₈	C106C	13.7	9 ³ / ₄	15 ⁵ / ₈	2 ¹ / ₄	2 ¹ / ₄ -14	1 ¹ / ₈	3/4	1 ¹ / ₂	1-8 x 3/4	1/4	1 ¹¹ / ₁₆	2.236	8,948	11.2	9.4
	8 ¹ / ₈	C108C	19.9	11 ³ / ₄	19 ⁷ / ₈	2 ¹ / ₄	2 ¹ / ₄ -14	1 ¹ / ₈	3/4	1 ¹ / ₂	1-8 x 3/4	1/4	1 ¹¹ / ₁₆	2.236	8,948	11.2	11
	10 ¹ / ₈	C1010C	22.6	13 ³ / ₄	23 ⁷ / ₈	2 ¹ / ₄	2 ¹ / ₄ -14	1 ¹ / ₈	3/4	1 ¹ / ₂	1-8 x 3/4	1/4	1 ¹¹ / ₁₆	2.236	8,948	11.2	13
	12 ¹ / ₈	C1012C	27.1	15 ³ / ₄	27 ⁷ / ₈	2 ¹ / ₄	2 ¹ / ₄ -14	1 ¹ / ₈	3/4	1 ¹ / ₂	1-8 x 3/4	1/4	1 ¹¹ / ₁₆	2.236	8,948	11.2	14.6
	14 ¹ / ₈	C1014C	31.6	17 ³ / ₄	31 ⁷ / ₈	2 ¹ / ₄	2 ¹ / ₄ -14	1 ¹ / ₈	3/4	1 ¹ / ₂	1-8 x 3/4	1/4	1 ¹¹ / ₁₆	2.236	8,948	11.2	16.2
16	C1016C	36.1	20 ¹ / ₂	36 ¹ / ₂	2 ¹ / ₄	2 ¹ / ₄ -14	1 ¹ / ₈	3/4	1 ¹ / ₂	1-8 x 3/4	1/4	1 ¹¹ / ₁₆	2.236	8,948	11.2	18.5	
15	1	C151C	3.1	4 ⁷ / ₈	5 ⁷ / ₈	2 ³ / ₄	2 ³ / ₄ -16	1 ¹ / ₈	3/4	1 ³ / ₄	1-8 x 3/4	1/4	2	3.142	9,549	15.7	7.5
	2 ¹ / ₈	C152C	6.7	5 ⁷ / ₈	8	2 ³ / ₄	2 ³ / ₄ -16	1 ¹ / ₈	3/4	1 ³ / ₄	1-8 x 3/4	1/4	2	3.142	9,549	15.7	8.9
	4 ¹ / ₈	C154C	12.9	7 ⁷ / ₈	12	2 ³ / ₄	2 ³ / ₄ -16	1 ¹ / ₈	3/4	1 ³ / ₄	1-8 x 3/4	1/4	2	3.142	9,549	15.7	11.5
	6 ¹ / ₈	C156C	19.2	10 ¹¹ / ₁₆	16 ¹³ / ₁₆	2 ³ / ₄	2 ³ / ₄ -16	1 ¹ / ₈	3/4	1 ³ / ₄	1-8 x 3/4	1/4	2	3.142	9,549	15.7	15.3
	8 ¹ / ₈	C158C	25.5	12 ¹¹ / ₁₆	20 ¹³ / ₁₆	2 ³ / ₄	2 ³ / ₄ -16	1 ¹ / ₈	3/4	1 ³ / ₄	1-8 x 3/4	1/4	2	3.142	9,549	15.7	17.9
	10 ¹ / ₈	C1510C	31.8	14 ¹¹ / ₁₆	24 ¹³ / ₁₆	2 ³ / ₄	2 ³ / ₄ -16	1 ¹ / ₈	3/4	1 ³ / ₄	1-8 x 3/4	1/4	2	3.142	9,549	15.7	20.7
	12 ¹ / ₈	C1512C	38.1	16 ¹¹ / ₁₆	28 ¹³ / ₁₆	2 ³ / ₄	2 ³ / ₄ -16	1 ¹ / ₈	3/4	1 ³ / ₄	1-8 x 3/4	1/4	2	3.142	9,549	15.7	23.2
	14 ¹ / ₈	C1514C	44.4	18 ¹¹ / ₁₆	32 ¹³ / ₁₆	2 ³ / ₄	2 ³ / ₄ -16	1 ¹ / ₈	3/4	1 ³ / ₄	1-8 x 3/4	1/4	2	3.142	9,549	15.7	26
16	C1516C	50.3	20 ⁹ / ₁₆	36 ⁹ / ₁₆	2 ³ / ₄	2 ³ / ₄ -16	1 ¹ / ₈	3/4	1 ³ / ₄	1-8 x 3/4	1/4	2	3.142	9,549	15.7	28.2	
25	1	C251C	5.1	5 ¹ / ₂	6 ¹ / ₂	3 ³ / ₈	3 ⁵ / ₁₆ -12	1 ¹⁵ / ₁₆	1	2 ¹ / ₄	1 ¹ / ₂ -16 x 7/8	3/8	2 ⁹ / ₁₆	5.15	9,699	25.8	11.9
	2	C252C	10.3	6 ¹ / ₂	8 ¹ / ₂	3 ³ / ₈	3 ⁵ / ₁₆ -12	1 ¹⁵ / ₁₆	1	2 ¹ / ₄	1 ¹ / ₂ -16 x 7/8	3/8	2 ⁹ / ₁₆	5.15	9,699	25.8	13.9
	4	C254C	20.6	8 ¹ / ₂	12 ¹ / ₂	3 ³ / ₈	3 ⁵ / ₁₆ -12	1 ¹⁵ / ₁₆	1	2 ¹ / ₄	1 ¹ / ₂ -16 x 7/8	3/8	2 ⁹ / ₁₆	5.15	9,699	25.8	17.6
	6 ¹ / ₄	C256C	32.2	10 ³ / ₄	17	3 ³ / ₈	3 ⁵ / ₁₆ -12	1 ¹⁵ / ₁₆	1	2 ¹ / ₄	1 ¹ / ₂ -16 x 7/8	3/8	2 ⁹ / ₁₆	5.15	9,699	25.8	21.7
	8 ¹ / ₄	C258C	42.5	12 ³ / ₄	21	3 ³ / ₈	3 ⁵ / ₁₆ -12	1 ¹⁵ / ₁₆	1	2 ¹ / ₄	1 ¹ / ₂ -16 x 7/8	3/8	2 ⁹ / ₁₆	5.15	9,699	25.8	25.6
	10 ¹ / ₄	C2510C	52.8	14 ³ / ₄	25	3 ³ / ₈	3 ⁵ / ₁₆ -12	1 ¹⁵ / ₁₆	1	2 ¹ / ₄	1 ¹ / ₂ -16 x 7/8	3/8	2 ⁹ / ₁₆	5.15	9,699	25.8	29.3
	12 ¹ / ₄	C2512C	63.2	16 ³ / ₄	29	3 ³ / ₈	3 ⁵ / ₁₆ -12	1 ¹⁵ / ₁₆	1	2 ¹ / ₄	1 ¹ / ₂ -16 x 7/8	3/8	2 ⁹ / ₁₆	5.15	9,699	25.8	33.1
	14 ¹ / ₄	C2514C	73.5	18 ³ / ₄	33	3 ³ / ₈	3 ⁵ / ₁₆ -12	1 ¹⁵ / ₁₆	1	2 ¹ / ₄	1 ¹ / ₂ -16 x 7/8	3/8	2 ⁹ / ₁₆	5.15	9,699	25.8	36.8
55	2	C552C	22.1	6 ⁷ / ₈	8 ⁷ / ₈	5	5-12	2 ⁵ / ₁₆	1 ³ / ₈	3 ³ / ₈	None	1/8	3 ³ / ₄	11.04	9,959	55.2	32.5
	4 ¹ / ₄	C554C	46.9	9 ¹ / ₈	13 ³ / ₈	5	5-12	2 ⁵ / ₁₆	1 ³ / ₈	3 ³ / ₈	None	1/8	3 ³ / ₄	11.04	9,959	55.2	41.3
	6 ¹ / ₄	C556C	69.0	11 ¹ / ₈	17 ³ / ₈	5	5-12	2 ⁵ / ₁₆	1 ³ / ₈	3 ³ / ₈	None	1/8	3 ³ / ₄	11.04	9,959	55.2	51
	10 ¹ / ₄	C5510C	113.2	15 ¹ / ₈	25 ³ / ₈	5	5-12	2 ⁵ / ₁₆	1 ³ / ₈	3 ³ / ₈	None	1/8	3 ³ / ₄	11.04	9,959	55.2	67
	13 ¹ / ₄	C5513C	146.3	18 ³ / ₈	31 ³ / ₈	5	5-12	2 ⁵ / ₁₆	1 ³ / ₈	3 ³ / ₈	None	1/8	3 ³ / ₄	11.04	9,959	55.2	78
75	6 ¹ / ₈	C756C	97.4	12 ³ / ₈	18 ¹ / ₂	5 ³ / ₄	5 ³ / ₄ -12	1 ³ / ₄	1 ¹ / ₄	3 ³ / ₄	None	1/8	4 ¹ / ₂	15.90	9,434	79.5	73.5
	13 ¹ / ₈	C7513C	208.7	19 ³ / ₈	32 ¹ / ₂	5 ³ / ₄	5 ³ / ₄ -12	1 ³ / ₄	1 ¹ / ₄	3 ³ / ₄	None	1/8	4 ¹ / ₂	15.90	9,434	79.5	109.5
	2	C1002C	41.2	8 ³ / ₈	10 ³ / ₈	6 ¹ / ₄	6 ¹ / ₄ -12	2 ¹ / ₄	1 ⁵ / ₈	4 ¹ / ₈	None	1/8	5 ¹ / ₈	20.62	9,695	103.1	63
	6 ⁵ / ₈	C1006C	137.0	13 ³ / ₄	19 ³ / ₈	6 ¹ / ₄	6 ¹ / ₄ -12	2 ¹ / ₄	1 ⁵ / ₈	4 ¹ / ₈	None	1/8	5 ¹ / ₈	20.62	9,695	103.1	91
10 ¹ / ₄	C10010C	211.5	16 ³ / ₈	27 ³ / ₈	6 ¹ / ₄	6 ¹ / ₄ -12	2 ¹ / ₄	1 ⁵ / ₈	4 ¹ / ₈	None	1/8	5 ¹ / ₈	20.62	9,695	103.1	113	

THREADED END

CBT Series

5-25 TONS Single Acting,
Spring-Return



CYLINDERS

THREADED PISTON ROD END AND BASE THREADS ACCOMMODATE ACCESSORIES AND ADAPTERS.

- Threaded cylinder collars, piston rod ends, and internal base threads simplify mounting.
- A 9796 3/8" NPTF female half coupler is standard with each cylinder; oil port threads are 3/8" NPTF.

ASME B30.1
10,000 PSI



C55CBT

C2514CBT

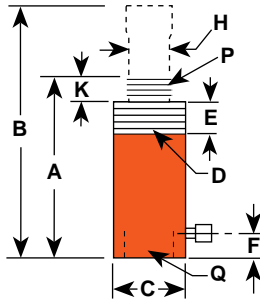

Cyl. Cap. (tons)	Stroke (in.)	Order No.	Oil Cap. (cu. in.)	A	B	C	D	E	F	H	K	P	Q	Bore Dia. (in.)	Cyl. Eff. Area (sq. in.)	Internal Press. at Cap. (psi)	Tons at 10,000 (psi)	Prod. Wt. (lbs.)
				Re-tracted Height (in.)	Ex-tended Height (in.)	Outside Dia. (in.)	Collar Thread (in.)	Collar Thread Length (in.)	Base to Port (in.)	Piston Rod Dia. (in.)	Piston Rod Protrusion (in.)	Piston Rod Thread* (NPT)	Internal Base Thread (NPSM) (in.)					
5	5 1/4	C55CBT	5.2	10 1/2	15 3/4	1 1/2	1 1/2-16	1 1/8	1 7/8	1	1 1/8	3/4-14	3/4-14	1 1/8	.994	10,061	4.97	4.4
10	6 1/8	C106CBT	13.9	11 1/2	17 5/8	2 1/4	2 1/4-14	1 1/8	1 11/16	1 1/2	1 1/16	1 1/4-11 1/2	1 1/4-11 1/2	1 11/16	2.236	8,948	11.2	10.3
	10 1/8	C1010CBT	22.9	15 1/2	25 5/8	2 1/4	2 1/4-14	1 1/8	1 11/16	1 1/2	1 1/16	1 1/4-11 1/2	1 1/4-11 1/2	1 11/16	2.236	8,948	11.2	13.9
25	6 1/4	C256CBT	32.2	13 3/8	19 5/8	3 3/8	3 5/16-12	1 15/16	1 7/8	2 1/4	1 7/8	2-11 1/2	2-11 1/2	2 9/16	5.157	9,699	25.8	24.6
	14 1/4	C2514CBT	73.5	21 3/8	35 5/8	3 3/8	3 5/16-12	1 15/16	1 7/8	2 1/4	1 7/8	2-11 1/2	2-11 1/2	2 9/16	5.157	9,699	25.8	40.2

ALUMINUM

RA-SERIES

20-100 TONS

Single Acting, Spring-Return

HALF THE WEIGHT OF EQUAL CAPACITY STEEL CYLINDERS.

- Aluminum body resists sparking in explosive environments.
- Hard coated aluminum piston rod and cylinder bore resist wear and corrosion.
- Grooved piston top helps keep the load from sliding on top of piston.
- Designed for jacking and other non-production operations.



ASME B30.1
10,000 PSI



CYLINDERS



RA1006

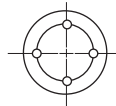
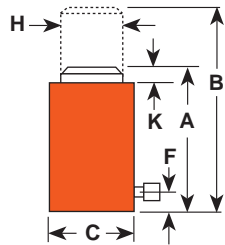

Base Mtg. Holes (4) at 45° from coupler (RA556, RA5510)
3/8"-16 x 4 1/2" Dia. B.C.

Cyl. Cap. (tons)	Order No.	Oil Cap. (cu. in.)	A Retracted Ht. (in.)	B Extended Ht. (in.)	C Outside Dia. (in.)	F Base to Port (in.)	H Piston Rod Dia. (in.)	K Piston Rod Protrusion (in.)	Bore Dia. (in.)	Cylinder Effective Area (sq. in.)	Internal Pressure at Cap. (psi)	Tons at 10,000 psi	Product Wt. (lbs.)
20	2 1/8 RA202	9.41	6 3/8	8 1/2	3 3/4	1 1/4	2	5/16	2 3/8	4.43	9,030	22.15	7.7
	4 1/8 RA204	18.27	8 3/8	12 1/2	3 3/4	1 1/4	2	5/16	2 3/8	4.43	9,030	22.15	9.3
	6 1/8 RA206	27.13	10 3/8	16 1/2	3 3/4	1 1/4	2	5/16	2 3/8	4.43	9,030	22.15	11.3
30	2 1/8 RA302	13.79	7 3/8	9 1/2	4 1/4	1 1/4	2 1/2	3/8	2 7/8	6.49	9,250	32.45	11.1
	4 1/8 RA304	26.77	9 3/8	13 1/2	4 1/4	1 1/4	2 1/2	3/8	2 7/8	6.49	9,250	32.45	13.1
	6 1/8 RA306	39.75	11 3/8	17 1/2	4 1/4	1 1/4	2 1/2	3/8	2 7/8	6.49	9,250	32.45	15.1
55	2 1/8 RA552	23.50	6 3/4	8 7/8	5 1/4	1 3/8	3 1/8	1/4	3 3/4	11.04	9,960	55.2	16.2
	4 1/8 RA554	45.50	8 3/4	12 7/8	5 1/4	1 3/8	3 1/8	1/4	3 3/4	11.04	9,960	55.2	19.6
	6 1/8 RA556*	67.60	10 3/4	16 7/8	5 1/4	1 3/8	3 1/8	1/4	3 3/4	11.04	9,960	55.2	24.0
100	10 RA5510*	110.40	15 1/8	25 1/8	5 1/4	1 3/8	3 1/8	1/4	3 3/4	11.04	9,960	55.2	31.8
	2 1/8 RA1002	43.80	7 3/4	9 7/8	7 3/8	1 3/16	4 1/8	1/8	5 1/8	20.62	9,696	103.1	33.4
	6 1/4 RA1006*	129.00	11 3/4	18	7 3/8	1 3/16	4 1/8	1/8	5 1/8	20.62	9,696	103.1	49.9

* Equipped with carrying handles.

LOW PROFILE

RLS Series

5-150 Ton

Single-Acting, Spring-Return



CYLINDERS

IDEAL FOR CONFINED AREAS FROM 1⁵/₈" TO 4" CLEARANCE.

- Cylinder body, piston and gland nut "Power Tech" treated for corrosion and abrasion resistance (see page 8).
- Standard domed piston rod (5-30 ton) or swivel cap (50-150 ton) minimize effects of off-center loading.
- Unique heavy duty spring provides fast piston return.
- A 9796 3³/₈" NPTF female half coupler is standard with each cylinder (the RLS50 has a 3³/₈" coupler which is not angled). Oil ports are 3³/₈" NPTF.
- Couplers on all cylinders, except RLS50, are angled upward for extra clearance.



RLS100



ASME B30.1
10,000 PSI



RLS1000S

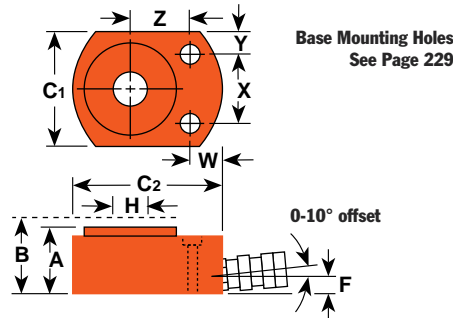

Cyl. Cap. (tons)	Stroke (in.)	Order No.	Oil Cap. (cu. in.)	A	B	C1 & C2	F	H	W	X	Y	Z	Bore Dia. (in.)	Cyl. Area (sq. in.)	Eff. at Cap. (psi)	Int. Press. (psi)	Tons at 10,000 psi	Prod. Wt. (lbs.)
				Re-tracted Height (in.)	Ex-tended Height (in.)	Outside Dia. (in.)	Base to Port (in.)	Piston Rod Dia. (in.)	Mounting Hole Location (in.)									
5	9/16	RLS50	.62	1 ⁵ / ₈	2 ³ / ₁₆	1 ⁵ / ₈ X 2 ⁹ / ₁₆	3/4	5/8	3/4	1 ¹ / ₈	1/4	1	1 ¹ / ₈	.994	10,061	4.97	2.2	
10	7/16	RLS100	1.0	1 ³ / ₄	2 ³ / ₁₆	2 ³ / ₁₆ X 3 ¹ / ₄	5/8	3/4	1 ¹ / ₁₆	1 ⁷ / ₁₆	3/8	1 ⁵ / ₁₆	1 ¹¹ / ₁₆	2.236	8,943	11.18	3.3	
20	7/16	RLS200	2.0	2	2 ⁷ / ₁₆	3 X 4	2 ¹ / ₃₂	1 ¹ / ₈	2 ³ / ₃₂	1 ¹⁵ / ₁₆	1 ⁷ / ₃₂	1 ⁹ / ₁₆	2 ³ / ₈	4.430	9,029	22.15	5.6	
30	1/2	RLS300	3.2	2 ⁵ / ₁₆	2 ¹³ / ₁₆	3 ³ / ₄ X 4 ¹ / ₂	2 ³ / ₃₂	1 ³ / ₈	1 ³ / ₁₆	2 ¹ / ₁₆	2 ⁷ / ₃₂	1 ³ / ₄	2 ⁷ / ₈	6.492	9,242	32.46	8.6	
50	5/8	RLS500S	6.0	2 ⁵ / ₈	3 ¹ / ₄	4 ¹ / ₂ X 5 ¹ / ₂	2 ⁷ / ₃₂	1 ³ / ₄	1 ⁵ / ₁₆	2 ⁵ / ₈	1 ⁵ / ₁₆	2 ¹ / ₈	3 ¹ / ₂	9.621	10,394	48.10	14.0	
75	5/8	RLS750S	9.9	3 ¹ / ₈	3 ³ / ₄	5 ¹⁷ / ₃₂ X 6 ¹ / ₂	1	2 ¹ / ₈	1 ⁵ / ₁₆	3	1 ¹⁷ / ₆₄	2 ¹⁹ / ₃₂	4 ¹ / ₂	15.904	9,431	79.52	23.3	
100	5/8	RLS1000S	12.3	3 ³ / ₈	4	6 X 7	1	2 ¹ / ₂	1 ³ / ₁₆	3	1 ¹ / ₂	2 ¹³ / ₁₆	5	19.635	10,186	98.17	30.0	
150	9/16	RLS1500S	17.2	4	4 ⁹ / ₁₆	7 ¹ / ₂ X 8 ¹ / ₂	1 ⁵ / ₁₆	3	1 ⁵ / ₁₆	4 ⁵ / ₈	1 ⁷ / ₁₆	3 ¹ / ₈	6 ¹ / ₄	30.680	9,778	153.39	52.0	

SHORTY

RSS Series

10-250 Ton

Single-Acting, Spring-Return
& Double-Acting

IDEAL FOR CONFINED AREAS FROM 3¹/₂" TO 11⁷/₁₆" CLEARANCE.

- Power Tech plated piston rods and gland nuts resist scoring and corrosion.
- Heavy duty return spring (except for double-acting models) provides fast piston return & low collapsed height.
- Coupler on 10 thru 50 ton models is angled upward 5° for added clearance.
- Grooved piston top keeps load from sliding.
- Cylinders can be "dead-ended" at full capacity.
- Removable carrying handles on 100 ton and 250 ton models.



RSS2503



Cribbing blocks are shown in a 30 ton RSS302 "Shorty" cylinder. For more information see pg 38.

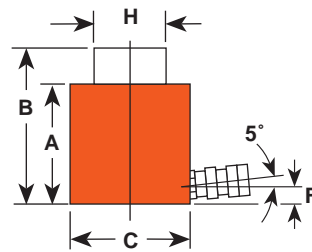

RSS302

ASME B30.1
10,000 PSI



Cyl Capacity (Tons)	Stroke (in.)	Order No.	Oil Cap. (cu. in.)		A Retracted Height (in.)	B Extended Height (in.)	C Outside Dia. (in.)	F Base to Port (in.)	H Piston Rod Dia. (in.)	Bore Dia. (in.)	Cylinder Effective Area (sq. in.)	Internal Press. at Cap. (psi)	Tons at 10,000 psi	Prod. Wt. (lbs.)
			Push	Return										
10	1 ¹ / ₂	RSS101	3.4	-	3 ¹ / ₂	5	2 ³ / ₄	5 ⁵ / ₈	1 ¹ / ₂	1 ¹¹ / ₁₆	2.24	8,943	11.2	6.0
20	1 ³ / ₄	RSS202	7.7	-	3 ³ / ₄	5 ¹ / ₂	3 ⁹ / ₁₆	5 ⁵ / ₈	2 ⁵ / ₃₂	2 ³ / ₈	4.43	9,029	22.1	9.9
30	2 ⁷ / ₁₆	RSS302	15.8	-	4 ⁵ / ₈	7 ¹ / ₁₆	4	5 ⁵ / ₈	2 ¹ / ₂	2 ⁷ / ₈	6.49	9,243	32.5	14.7
50	2 ³ / ₈	RSS502	22.8	-	5	7 ³ / ₈	4 ⁷ / ₈	3 ³ / ₄	3 ¹ / ₈	3 ¹ / ₂	9.62	10,393	48.1	23.2
100	2 ¹ / ₄	RSS1002	44.2	-	5 ¹ / ₂	7 ³ / ₄	6 ⁵ / ₈	1 ⁵ / ₁₆	4 ³ / ₈	5	19.63	10,186	98.2	47.3
100	1 ¹ / ₂	RSS1002D	29.4	12.9	5 ¹¹ / ₁₆	7 ³ / ₁₆	6 ⁷ / ₈	1 ⁵ / ₁₆ *	3 ³ / ₄	5	19.63	10,186	98.2	54.6
250	3	RSS2503	150.6	-	11 ⁷ / ₁₆	14 ⁷ / ₁₆	9 ⁷ / ₈	1 ¹³ / ₁₆	5 ¹ / ₂	8	50.22	9,956	251.1	220.0

*Cylinder top to port is 1⁹/₁₆

See pages 28-33 & 124-133 for hydraulic accessories.

CENTER HOLE

RH Series

10-100 Ton

Single-Acting, Spring-Return



CYLINDERS



ASME B30.1
10,000 PSI

10, 20, 100 Ton
Single-Acting Models
Feature Plain Collar

IDEAL FOR PULLING AND TENSIONING OF CABLES, ANCHOR BOLTS, FORCING SCREWS, ETC.

- Interchangeable piston head inserts (see page 39) provide versatility of application.
- 12, 20*, 30*, 50, 60 Ton Single-Acting Models Feature Threaded Collar
- Withstands full "dead-end" loads.
- Corrosion resistant standpipe has "Power Tech" treatment.
- All cylinders except RH120 are furnished with a 9796 3/8" NPT female half coupler.
- Aluminum cylinder body and piston are featured on the RHA306 cylinder.
- * Model RH203 and RHA306 do not feature the collar thread. See the chart below.

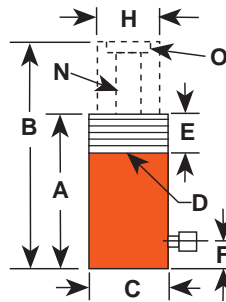

Cyl. Cap. (tons)	Stroke (in.)	Order No.	Oil Cap. (cu. in.)	A Re-traced Height (in.)	B Ex-tended Height (in.)	C Outside Dia. (in.)	D Collar Thread (in.)	E Collar Thread Length (in.)	F Base to Port (in.)	H Piston Rod Dia. (in.)	N Center Hole Dia. (in.)	O Insert and Size	Mounting Holes Bolt Circle (in.)	Cylinder Effective Area (sq. in.)	Internal Press. at Cap. (psi)	Tons at 10,000 psi	Prod. Wt. (lbs.)
10	2 1/2	RH102	5.52	5 5/16	7 13/16	3	None	None	1	2 1/16	49/64	1 3/4-12	1/4-20 x 2 3/8	2.21	9,054	11	9
10	8	RH108	17.68	11 5/16	19 5/16	3	None	None	1	2 1/16	49/64	1 3/4-12	1/4-20 x 2 3/8	2.21	9,054	11	18.7
12	5/16	RH120**	.87	2 3/16	2 1/2	2 3/4	2 3/4-16	1 1/4	3/8	1 3/8	11/16	3/4-16	5/16-18 x 2	2.76	8,692	13.8	3
12	1 5/8	RH121	4.49	4 13/16	6 7/16	2 3/4	2 3/4-16	1 1/4	1	1 3/8	51/64	None	None	2.76	8,692	13.8	6.6
12	1 5/8	RH121T**	4.49	4 13/16	6 7/16	2 3/4	2 3/4-16	1 1/4	1	1 3/8	11/16	3/4-16	None	2.76	8,692	13.8	6.6
12	3	RH123	8.29	7 1/4	10 1/4	2 3/4	2 3/4-16	1 3/16	1	1 3/8	13/16	None	None	2.76	8,692	13.8	8.9
20	2	RH202	9.45	6 1/8	8 1/8	3 7/8	3 7/8-12	1 1/2	1	2 1/8	15/64	1 9/16-16	3/8-16 x 3 1/4	4.72	8,466	23.6	16.1
20	3	RH203	11.76	6 1/16	9 1/16	4	None	None	1	2 3/4	13/64	2 1/4-12	3/8-16 x 3 1/4	3.92	10,186	19.6	20
20	6	RH206	28.35	12 1/8	18 1/8	3 7/8	3 7/8-12	1 1/2	1	2 1/8	15/64	1 9/16-16	3/8-16 x 3 1/4	4.72	8,466	23.6	30.2
30	2 1/2	RH302	15.85	6 1/4	8 3/4	4 3/4	4 3/4-12	1 1/2	1 5/32	3 1/4	1 19/64	2 3/4-12	7/16-20 x 3 5/8	6.34	9,457	31.7	25.6
30	5 7/8	RHA306	38.1	11 5/32	17 1/32	5 1/8	None	None	1 1/4	3 1/4	1 9/32	2 5/8-8	None	6.34	9,457	31.7	21.9
30	6	RH306	38.1	9 3/4	15 3/4	4 3/4	4 3/4-12	1 1/2	1 5/32	3 1/4	1 9/32	2 3/4-12	7/16-20 x 3 5/8	6.34	9,457	31.7	39
50	3	RH503	32.58	7 1/8	10 1/8	6	6-12	2	1 1/4	4 1/8	1 43/64	3 1/4-12	5/8-18 x 4 3/4	10.86	9,208	54.3	46.6
60	3	RH603*	37	9 1/4	12 1/4	6 1/4	6 1/4-12	2 1/2	1	3 19/32	2 1/8	3-12	1/2-13 x 5 1/8	12.31	9,750	61.6	60
60	6	RH606*	73.86	12 1/4	18 1/4	6 1/4	6 1/4-12	2 1/2	1	3 19/32	2 1/8	3-12	1/2-13 x 5 1/8	12.31	9,750	61.6	78
100	3	RH1003*	61.8	10	13	8 3/8	None	None	1 1/4	5	3 1/8	4 1/8-12	None	20.62	9,700	103.1	115

*Supplied with carrying handles.

Aluminum

** RH120 and RH121T do not have an internal threaded insert, but do have a 3/4-16 internal thread. The RH120 inlet port is 1/4" NPTF.

CENTER HOLE

RH Series

30-200 Ton
Double-Acting,

FOR PULLING AND TENSIONING OF CABLES, ANCHOR BOLTS, FORCING SCREWS.

- Interchangeable piston head inserts (see page 39) provide versatility of application.
- Built-in safety feature prevents over-pressurization of the retract circuit.
- Plated piston rod resists wear; superior packings provide high cycle life without leakage.
- Corrosion-resistant standpipe has "Power Tech" treatment (see page 8).
- Each cylinder has 9796 3/8" NPTF female half couplers. The 60 ton thru 200 ton steel models are equipped with removable carrying handles.



ASME B30.1
10,000 PSI

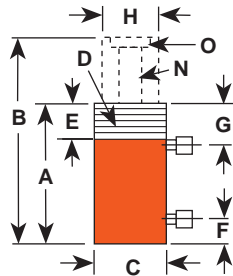

30, 60, 100 Ton
Double-Acting Models Feature
Threaded Collar

Cyl. Cap. (tons)	Stroke (in.)	Order No.	Oil Cap. (cu.in.)		A	B	C	D	E	F	G	H	N	O	Mounting Holes and Bolt Circle (in.)	Cylinder Effective Area (sq.in.)		Internal Pressure at Cap. (psi)		Tons at 10,000 psi (in.)		Prod. Wt (lbs.)	
			Push	Pull												Push	Pull	Push	Pull	Push	Pull		
30	15	3	RH303	17.6	10.2	7 ¹ / ₁₆	10 ¹ / ₁₆	4 ³ / ₄	None	None	1	1 ⁵ / ₈	2 ¹ / ₂	1 ⁹ / ₃₂	2-12	3 ³ / ₈ -16x3 ⁵ / ₈	5.89	3.38	10,200	8,876	29.5	16.9	29.8
30	15	6	RH306D	35.34	20.28	11 ¹ / ₁₆	17 ¹ / ₁₆	4 ³ / ₄	None	None	1	1 ⁵ / ₈	2 ¹ / ₂	1 ¹⁷ / ₆₄	2-12	7 ¹ / ₁₆ -20x3 ⁵ / ₈	5.89	3.38	10,200	8,876	29.5	16.9	45
30	20	10 ¹ / ₈	RH3010	66	41	17 ¹ / ₄	27 ³ / ₈	4 ¹ / ₂	4 ¹ / ₂ -12	1 ⁵ / ₈	1 ³ / ₄	3 ³ / ₁₆	2 ³ / ₈	1 ⁵ / ₁₆	1 ⁷ / ₈ -16	None	6.54	4.04	9,174	9,901	32.7	20.2	61
60	25	4	RHA604D	49.2	20.6	9 ¹ / ₂	13 ¹ / ₂	7	None	None	1 ⁹ / ₁₆	2 ¹ / ₄	4	2 ¹ / ₈	3-12	1 ¹ / ₂ -13x5 ¹ / ₈	12.31	5.15	9,750	9,709	61.5	27.7	35.6
60	25	5	RH605*	61.55	25.77	9 ¹ / ₂	14 ¹ / ₂	6 ¹ / ₃₂	None	None	1	1 ³ / ₄	4	2 ¹ / ₈	3-12	1 ¹ / ₂ -13x5 ¹ / ₈	12.31	5.15	9,750	9,709	61.5	27.7	73
60	40	10 ¹ / ₈	RH6010*	133	87	18 ¹ / ₁₆	28 ³ / ₁₆	6 ¹ / ₄	6 ¹ / ₄ -12	1 ⁷ / ₈	2 ¹ / ₈	3 ⁷ / ₃₂	3 ⁵ / ₈	2 ¹ / ₈	3-16	None	13.14	8.59	9,132	9,313	65.7	42.9	120
100	45	1 ¹ / ₂	RH1001	32.1	14.2	6 ¹ / ₂	8	8 ³ / ₈	None	None	1 ¹ / ₄	2 ⁵ / ₁₆	5	3 ⁹ / ₆₄	4-16	5 ⁵ / ₈ -11x7	21.39	9.43	9,350	9,544	106.9	47.1	85
100	50	6	RH1006*	120.26	5.6	12 ³ / ₈	18 ³ / ₈	7 ¹ / ₄	None	None	1 ¹⁵ / ₃₂	2 ²¹ / ₆₄	4 ³ / ₈	2 ¹ / ₁₆	None	1 ¹ / ₂ -13x5 ¹ / ₂	20.03	10.93	9,986	9,150	100.1	54.7	95
100	45	10 ¹ / ₈	RH10010*	216.6	95.5	19 ¹ / ₂	29 ⁵ / ₈	8 ¹ / ₂	8 ¹ / ₂ -12	2 ¹ / ₄	2 ¹ / ₂	3 ³⁹ / ₆₄	5 ¹ / ₂	3 ⁹ / ₆₄	4 ¹ / ₂ -12	None	21.39	9.43	9,350	9,544	106.9	47.1	240
150	70	5	RH1505*	150.9	73.6	12 ² / ₄ †	17 ¹ / ₄	8 ¹ / ₂	None	None	1 ¹⁵ / ₃₂	2 ¹¹ / ₁₆	5 ¹ / ₂	2 ⁹ / ₁₆	None	None	30.1	14.7	9,937	9,524	150.9	73.6	148
150	75	8	RH1508*	239.6	127.2	13 ³ / ₄	21 ³ / ₄	9 ³ / ₄	None	None	1 ³⁵ / ₆₄	2 ¹³ / ₃₂	6	3 ⁵ / ₃₂	5-12	None	29.95	15.9	10,015	9,434	149.8	79.5	227
200	75	8	RH2008*	323.6	127.6	16 ¹ / ₁₆	24 ¹ / ₁₆	10 ³ / ₄	None	None	2 ¹ / ₄	3 ⁷ / ₃₂	7 ¹ / ₂	4 ¹ / ₁₆	6-12	1 ¹ / ₄ -7 x 7 ³ / ₄	40.45	15.95	9,888	9,404	202.3	79.8	311

* Supplied with carrying handles.

† Measured with 3/4" high serrated insert installed.

See pages 34-39 & 104-133 for hydraulic accessories.

Aluminum

CENTER HOLE

RT Series

17¹/₂-100 Ton

Single- Acting, Spring-
Return & Double-Acting



CYLINDERS



RT 302

ASME B30.1
10,000 PSI

IDEAL FOR PULLING AND PRESSING.

- A proven design; used throughout industry for over 45 years.
- Cylinders withstand full “dead-end” loads.
- Compact design; ideal for applications in which space is limited.
- Basic head can be changed from a tapped hole to plain hole by simply changing insert. (See page 39)
- Pistons have “Power Tech” treatment for corrosion and abrasion resistance.

Dimensions for reference only. Single-Acting, Spring-Return Cylinders

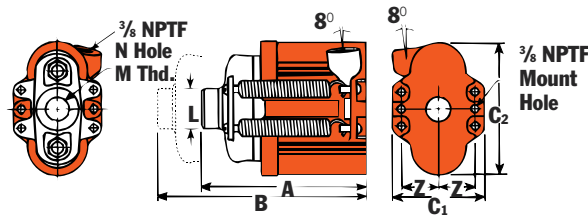

Double-Acting Cylinder (RT1004)

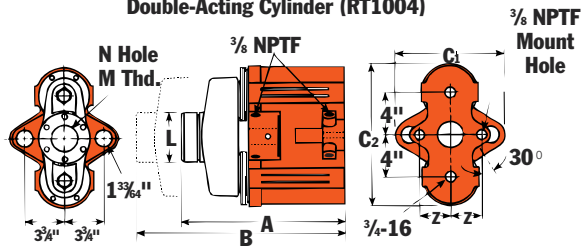

RT 1004

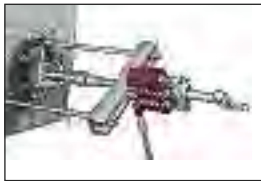

Cyl. Capacity (Tons)	Stroke (in.)	Order No.	Oil Cap. (cu.in.)		A Re- tracted Height (in.)	B Ex- tended Height (in.)	C1 Out- side Dia. (in.)	C2 Out- side Dia. (in.)	L Load Cap Dia. (in.)	M Load Cap Thread (in.)	N Center Hole Dia. (in.)	Z Mounting Hole Location (in.)	Cyl. Mounting Hole (in.)	Int. Press at Cap. (psi)	Tons at 10,000 psl	Prod Wt. (lbs.)	
			Push	Return													
17 1/2	2	RT172	7.06	-	6 ⁷ / ₈	8 ⁷ / ₈	3 ³ / ₄	5 ³ / ₄	1 ³ / ₄	1"-8	1 ¹ / ₃₂	1 ¹ / ₂	1 ¹¹ / ₃₂	3.53	9,915	17.7	14.6
30	2 ¹ / ₂	RT302	15.7	-	8 ⁷ / ₁₆	10 ¹⁵ / ₁₆	4 ¹ / ₄	7 ¹ / ₂	2 ¹ / ₄	1 ¹ / ₄ "-7	1 ¹⁹ / ₆₄	1 ¹³ / ₁₆	1 ¹⁵ / ₃₂	6.28	9,554	31.4	28.2
50	3	RT503	29.4	-	10 ⁹ / ₁₆	13 ⁹ / ₁₆	5 ⁷ / ₈	9 ³ / ₈	2 ⁷ / ₈	1 ⁵ / ₈ "-5 ¹ / ₂	1 ⁴³ / ₆₄	2 ³ / ₈	2 ¹ / ₃₂	9.81	10,193	49.1	56.0
100	4 ⁷ / ₈ **	RT1004	96.5	63.2	15 ¹ / ₈	20	10 ¹ / ₂	13 ³ / ₄	4 ³ / ₄	2 ¹ / ₂ "-8	2 ⁹ / ₁₆	2 ⁷ / ₈	2 ⁵ / ₃₂	19.24*	10,395	96.2	160

** The RT1004 has a bypass when full stroke is reached, preventing over-pressurization of the cylinder.

NOTE: Each cylinder complete with threaded cylinder head insert, cylinder half coupler and cylinder attaching screws.

PULLING

RP Series

2 & 5 Ton

Single-Acting, Spring-Return



CYLINDERS

DESIGNED FOR PULLING AND TENSIONING.

- Heavy duty compression spring provides long cycle life and rapid extension of piston.
- Spring automatically extends piston rod when pump pressure is released.



RP55



RP25

ASME B30.1
10,000 PSI

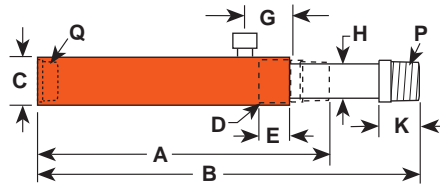

Cyl. Cap. (Tons)	Stroke (in.)	Order No.	Oil Cap. (cu. in.)	A Re-tracted Height (in.)	B Ex-tended Height (in.)	C Outside Dia. (in.)	D Collar Thread (in.)	E Collar Thread Length (in.)	G Cylinder Top to Port (in.)	H Piston Rod Dia. (in.)	K Piston Rod Protrusion (in.)	P Piston Rod Thread (NPTF)	Q Piston Rod Thread (NPTF)	Bore Dia. (in.)	Cyl. Eff. Area (sq. in.)	Internal Pressure at Cap. (psi)	Tons at 10,000 psi Pull	Prod. Wt. (lbs.)
2	5	RP25	2.76	9 ⁹ / ₁₆	14 ⁹ / ₁₆	1 ³ / ₄	1 ¹ / ₂ -16	1	1 ¹¹ / ₁₆	3/4	1	3/4-14	3/4-14	1 ¹ / ₈	0.55	7,250	2.75	4
5	5 ¹ / ₂	RP55	6.22	11 ⁷ / ₈	17 ³ / ₈	2 ¹ / ₄	2 ¹ / ₄ -14	1	1 ¹¹ / ₁₆	1 ³ / ₁₆	1 ³ / ₈	1 ¹ / ₄ -11 ¹ / ₂	1 ¹ / ₄ -11 ¹ / ₂	1 ¹¹ / ₁₆	1.13	8,850	5.65	11

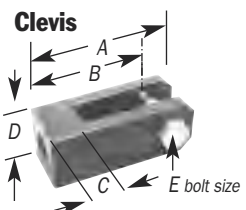

Clevis ORDERING INFORMATION

Use with Cyl. No.	Order No.	A (in.)	B (in.)	C (in.)	D (in.)	E (in.)
RP25	421057*	5 ¹ / ₈	4 ⁵ / ₁₆	1 ⁵ / ₁₆	2	3/4
RP55	421056**	6	5	1 ¹ / ₂	2 ¹ / ₂	7/8

* For base mounting, extension rod 351106 is required.
 ** For base mounting, extension rod 351075 is required.

DOUBLE ACTING

RD Series

10-500 Ton

Double Acting, Hydraulic-Return



CYLINDERS

HIGH TONNAGE PREMIUM DESIGN FOR HIGH CYCLE LIFE.

- Perfect for bridge lifting, building reconstruction, shipyard, utility and mining equipment maintenance.
- Aluminum bronze overlay bearings provide long life, chrome plated piston rod resists corrosion.
- Load cap snaps out to expose internal piston rod threads for pulling applications; threads withstand full tonnage.
- Grooved ring pattern in load cap helps guard against load slippage.
- Each cylinder has two 9796 3/8" NPTF female half couplers.
- Built-in safety relief valve prevents over-pressurization of the retract circuit.
- Feature mounting holes and collar threads.



Four special order 500 ton, 24" stroke cylinders used in a swaging press for crimping 3 1/2" wire rope.



RD10013

ASME B30.1
10,000 PSI



RD300



RD556

Features of RD Series Cylinders

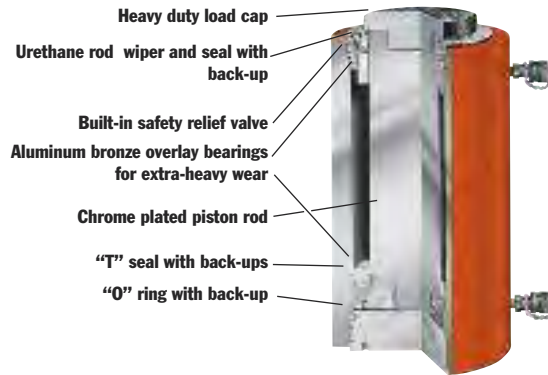

Threads withstand full load.

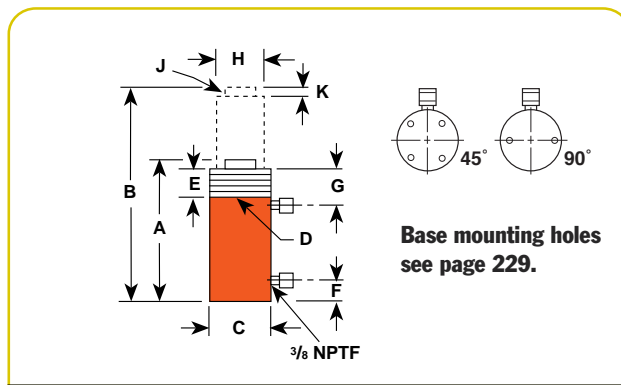
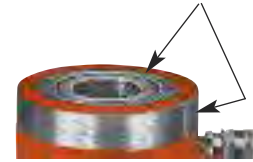

Cyl. Cap (tons)	Stroke (in.)	Order No.	Oil Capacity (cu.in.)		A Re-traced Height (in.)	B Extended Height (in.)	C Outside Dia. (in.)	D Collar Thread Size (in.)	E Thread Length (in.)	F Base Port (in.)	G Cylinder Top to Port (in.)	H Piston Rod Dia. (in.)	J Rod Int. and (in.)	K Piston Rod Pro-trusion (in.)	Load Cap		Cyl. Eff. Area (sq.in.)		Int. Press. at Cap.		Tons at 10,000 psi		Prod. Wt. (lbs.)		
			Push	Pull											Dia. (in.)	Bore Dia. (in.)	Push	Pull	Push	Pull	Push	Pull		Push	Pull
10	4	6 ¹ / ₄	RD106	13.9	5.5	11 ¹¹ / ₁₆	17 ¹⁵ / ₁₆	3	2 ³ / ₄ -12	1 ⁵ / ₈	1	2 ¹ / ₂	1 ⁵ / ₁₆	1-8x1	1 ¹ / ₄	1 ³ / ₈	1 ¹¹ / ₁₆	2.23	0.88	8,943	9,055	11.2	4.4	22	
10	4	10	RD1010	22.3	8.8	15 ¹¹ / ₁₆	25 ¹¹ / ₁₆	3	2 ³ / ₄ -12	1 ⁵ / ₈	1	2 ¹ / ₂	1 ⁵ / ₁₆	1-8x1	1 ¹ / ₄	1 ³ / ₈	1 ¹¹ / ₁₆	2.23	0.88	8,943	9,055	11.2	4.4	28	
25	8	6 ¹ / ₄	RD256	32.2	10.1	12 ³ / ₈	18 ⁵ / ₈	4	4-12	1 ⁵ / ₈	1	2 ¹ / ₂	2 ¹ / ₈	1 ¹ / ₂ -16x1	3 ³ / ₈	2 ¹ / ₈	2 ⁹ / ₁₆	5.15	1.61	9,695	9,934	25.8	8.0	39.8	
25	8	14 ¹ / ₄	RD2514	73.5	22.9	20 ³ / ₈	34 ⁵ / ₈	4	4-12	1 ⁵ / ₈	1	2 ¹ / ₂	2 ¹ / ₈	1 ¹ / ₂ -16x1	3 ³ / ₈	2 ¹ / ₈	2 ⁹ / ₁₆	5.15	1.61	9,695	9,934	25.8	8.0	65	
55	28	6 ¹ / ₄	RD556	69.0	35.2	12 ³¹ / ₃₂	19 ⁷ / ₃₂	5	5-12	1 ⁵ / ₈	1 ⁵ / ₁₆	2 ¹ / ₂	2 ⁵ / ₈	1 ¹¹ / ₁₆ -8x1 ³ / ₁₆	5 ⁵ / ₈	2 ⁵ / ₈	3 ³ / ₄	11.04	5.63	9,959	9,941	55.2	28.2	61.4	
55	28	13 ¹ / ₈	RD5513	144.9	73.9	19 ²⁷ / ₃₂	32 ³¹ / ₃₂	5	5-12	1 ⁵ / ₈	1 ⁵ / ₁₆	2 ¹ / ₂	2 ⁵ / ₈	1 ¹¹ / ₁₆ -8x1 ³ / ₁₆	5 ⁵ / ₈	2 ⁵ / ₈	3 ³ / ₄	11.04	5.63	9,959	9,941	55.2	28.2	90	
55	28	18 ¹ / ₈	RD5518	200.0	102.0	25 ⁷ / ₈	44	5	5-12	1 ⁵ / ₈	1 ⁵ / ₁₆	2 ¹ / ₂	2 ⁵ / ₈	1 ¹¹ / ₁₆ -8x1 ³ / ₁₆	5 ⁵ / ₈	2 ⁵ / ₈	3 ³ / ₄	11.04	5.63	9,959	9,941	55.2	28.2	142	
80	44	13 ¹ / ₈	RD8013	208.6	115.9	20 ³ / ₈	33 ¹ / ₂	5 ³ / ₄	5 ³ / ₄ -12	1 ⁵ / ₈	1 ¹ / ₂	2 ¹ / ₂	3	2-4 ¹ / ₂ x1 ¹ / ₂	9 ¹ / ₁₆	2 ⁷ / ₈	4 ¹ / ₂	15.90	8.84	10,060	9,954	79.5	44.2	118	
100	44	6 ⁵ / ₈	RD1006	136.7	58.5	13 ²⁵ / ₃₂	20 ¹³ / ₃₂	6 ⁷ / ₈	6 ⁷ / ₈ -12	1 ⁵ / ₈	1 ¹ / ₂	2 ¹ / ₂	3 ⁷ / ₈	2 ³ / ₄ -12x1 ⁵ / ₃₂	5 ⁵ / ₈	3 ⁷ / ₈	5 ¹ / ₈	20.63	8.84	9,695	9,959	103.1	44.2	126	
100	44	13 ¹ / ₈	RD10013	270.7	116.0	20 ⁹ / ₃₂	33 ¹³ / ₃₂	6 ⁷ / ₈	6 ⁷ / ₈ -12	1 ⁵ / ₈	1 ¹ / ₂	2 ¹ / ₂	3 ⁷ / ₈	2 ³ / ₄ -12x1 ⁵ / ₃₂	5 ⁵ / ₈	3 ⁷ / ₈	5 ¹ / ₈	20.63	8.84	9,695	9,959	103.1	44.2	181	
100	44	20 ¹ / ₈	RD10020	415.2	178.0	28 ⁹ / ₃₂	48 ¹³ / ₃₂	6 ⁷ / ₈	6 ⁷ / ₈ -12	1 ⁵ / ₈	1 ¹ / ₂	2 ¹ / ₂	3 ⁷ / ₈	2 ³ / ₄ -12x1 ⁵ / ₃₂	5 ⁵ / ₈	3 ⁷ / ₈	5 ¹ / ₈	20.63	8.84	9,695	9,959	103.1	44.2	260	
150	73	6 ⁵ / ₈	RD1506	203.3	97.9	14 ⁷ / ₈	21 ¹ / ₂	8 ¹ / ₄	8 ¹ / ₄ -12	1 ⁵ / ₈	2	2 ¹ / ₂	4 ¹ / ₂	3 ¹ / ₄ +8x1 ¹ / ₂	1 ¹³ / ₁₆	4 ¹ / ₂	6 ¹ / ₄	30.68	14.78	9,779	9,880	153.4	73.8	188	
150	73	13 ¹ / ₈	RD15013	402.7	193.9	21 ³ / ₈	34 ¹ / ₂	8 ¹ / ₄	8 ¹ / ₄ -12	1 ⁵ / ₈	2	2 ¹ / ₂	4 ¹ / ₂	3 ¹ / ₄ +8x1 ¹ / ₂	1 ¹³ / ₁₆	4 ¹ / ₂	6 ¹ / ₄	30.68	14.78	9,779	9,880	153.4	73.8	272	
150	73	18 ¹ / ₈	RD15018	556.8	267.8	26 ¹⁷ / ₃₂	44 ²¹ / ₃₂	8 ¹ / ₄	8 ¹ / ₄ -12	1 ⁵ / ₈	2	2 ¹ / ₂	4 ¹ / ₂	3 ¹ / ₄ +8x1 ¹ / ₂	3 ³ / ₄	4 ¹ / ₂	6 ¹ / ₄	30.68	14.78	9,779	9,880	153.4	73.8	376	
200	113	6 ⁵ / ₈	RD2006	273.5	149.8	16	22 ⁵ / ₈	9 ¹ / ₂	9 ¹ / ₂ -12	1 ⁵ / ₈	2 ¹ / ₂	2 ¹¹ / ₁₆	4 ⁷ / ₈	3 ¹ / ₄ +8x2 ¹ / ₄	1 ¹ / ₁₆	4 ¹ / ₂	7 ¹ / ₄	41.28	22.62	9,689	9,992	206.4	113.1	262	
200	113	13 ¹ / ₈	RD20013	541.8	296.9	22 ¹ / ₂	35 ⁵ / ₈	9 ¹ / ₂	9 ¹ / ₂ -12	1 ⁵ / ₈	2 ¹ / ₂	2 ¹¹ / ₁₆	4 ⁷ / ₈	3 ¹ / ₄ +8x2 ¹ / ₄	1 ¹ / ₁₆	4 ¹ / ₂	7 ¹ / ₄	41.28	22.62	9,689	9,992	206.4	113.1	356	
200	113	18 ¹ / ₈	RD20018	748.2	409.9	28 ¹ / ₂	46 ⁵ / ₈	9 ¹ / ₂	9 ¹ / ₂ -12	1 ⁵ / ₈	2 ¹ / ₂	2 ¹¹ / ₁₆	4 ⁷ / ₈	3 ¹ / ₄ +8x2 ¹ / ₄	1 ¹ / ₁₆	4 ¹ / ₂	7 ¹ / ₄	41.28	22.62	9,689	9,992	206.4	113.1	442	
300	147	6	RD3006	361.0	177.0	17 ⁹ / ₃₂	23 ⁹ / ₃₂	10 ³ / ₄	10 ¹ / ₂ -12	2 ³ / ₈	3 ³ / ₈	3 ³ / ₈	6 ¹ / ₄	2 ¹ / ₂ -12x3 ¹ / ₄	1 ¹ / ₈	6 ¹ / ₈	8 ³ / ₄	60.13	29.45	9,978	10,000	300.7	147.3	380	
300	147	13	RD30013	782.0	383.0	24 ¹³ / ₁₆	37 ¹³ / ₁₆	10 ³ / ₄	10 ¹ / ₂ -12	2 ³ / ₈	3 ³ / ₈	3 ³ / ₈	6 ¹ / ₄	2 ¹ / ₂ -12x3 ¹ / ₄	1 ¹ / ₈	6 ¹ / ₈	8 ³ / ₄	60.13	29.45	9,978	10,000	300.7	147.3	654	
400	186	6	RD4006	471.0	247.0	19 ³ / ₃₂	25 ³ / ₃₂	12 ⁵ / ₈	12 ¹ / ₂ -8	2 ³ / ₄	3 ²⁷ / ₃₂	3 ²⁷ / ₃₂	7 ¹ / ₄	3-12x3 ³ / ₄	1 ¹ / ₄	7 ¹³ / ₁₆	10	78.54	37.26	10,185	10,000	392.7	186.3	585	
400	186	13	RD40013	1021.0	536.0	26 ³ / ₃₂	39 ³ / ₃₂	12 ⁵ / ₈	12 ¹ / ₂ -8	2 ³ / ₄	3 ²⁷ / ₃₂	3 ²⁷ / ₃₂	7 ¹ / ₄	3-12x3 ³ / ₄	1 ¹ / ₄	7 ¹³ / ₁₆	10	78.54	37.26	10,185	10,000	392.7	186.3	770	
500	245	6	RD5006	596.0	295.0	20 ⁹ / ₁₆	26 ³ / ₁₆	14 ³ / ₄	14 ³ / ₄ -8	3 ¹ / ₈	4 ⁵ / ₃₂	4 ⁵ / ₃₂	8	3 ¹ / ₄ -12x4 ¹ / ₄	1 ¹ / ₂	8 ¹ / ₂	11 ¹ / ₄	99.40	49.14	10,060	10,000	497.0	245.6	819	
500	245	13	RD50013	1292.0	639.0	27 ⁹ / ₁₆	40 ⁹ / ₁₆	14 ³ / ₄	14 ³ / ₄ -8	3 ¹ / ₈	4 ⁵ / ₃₂	4 ⁵ / ₃₂	8	3 ¹ / ₄ -12x4 ¹ / ₄	1 ¹ / ₂	8 ¹ / ₂	11 ¹ / ₄	99.40	49.14	10,060	10,000	497.0	245.6	1092	

HIGH TONNAGE

R Series

55-565 Ton

Single-Acting Load-Return



CYLINDERS

HIGH-TONNAGE, LOW CYCLE, GRAVITY RETURN.

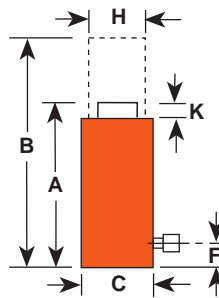

R2802C

ASME B30.1
10,000 PSI

- Visible indicator band alerts when stroke limit is reached; overflow port (“weep hole”) stroke limiter prevents piston from being overextended.
- Alloy heat treated piston and body for reliability and strength.
- Plated piston rod increases corrosion resistance and gives superior bearing support.

Cyl. Cap. (tons)	Stroke (in.)	Order No.	Oil Cap. (cu. in.)	A	B	C	F	H	K	Bore Dia. (in.)	Cylinder Effective Area (sq. in.)	Internal Pressure at Cap. (psi)	Tons at 10,000 psi	Product Wt. (lbs.)
				Retracted Ht. (in.)	Extended Ht. (in.)	Outside Dia. (in.)	Base to Port (in.)	Piston Rod Dia. (in.)	Piston Rod Protrusion (in.)					
55	2	R552C	22.1	4 ¹⁵ / ₁₆	6 ¹⁵ / ₁₆	5	1	3 ³ / ₄	1/8	3 ³ / ₄	11.04	9,960	55.2	27
55	6	R556C	66.3	8 ¹⁵ / ₁₆	14 ¹⁵ / ₁₆	5	1	3 ³ / ₄	1/8	3 ³ / ₄	11.04	9,960	55.2	50
55	10	R5510C	110.4	12 ¹⁵ / ₁₆	22 ¹⁵ / ₁₆	5	1	3 ³ / ₄	1/8	3 ³ / ₄	11.04	9,960	55.2	72
100	2	R1002C	41.3	5 ¹ / ₂	7 ¹ / ₂	6 ¹ / ₂	1	5 ¹ / ₈	1/8	5 ¹ / ₈	20.63	9,695	103.2	52
100	6	R1006C	123.8	9 ¹ / ₂	15 ¹ / ₂	6 ¹ / ₂	1	5 ¹ / ₈	1/8	5 ¹ / ₈	20.63	9,695	103.2	89
150	2	R1502C	61.4	6 ³ / ₈	8 ³ / ₈	8 ¹ / ₁₆	1 ¹ / ₄	6 ¹ / ₄	1/8	6 ¹ / ₄	30.68	9,778	153.4	92
150	6	R1506C	184.1	10 ³ / ₈	16 ³ / ₈	8 ¹ / ₁₆	1 ¹ / ₄	6 ¹ / ₄	1/8	6 ¹ / ₄	30.68	9,778	153.4	151
150	10	R15010C	306.8	14 ³ / ₈	24 ³ / ₈	8 ¹ / ₁₆	1 ¹ / ₄	6 ¹ / ₄	1/8	6 ¹ / ₄	30.68	9,778	153.4	210
200	2	R2002C	82.6	7 ¹ / ₂	9 ¹ / ₂	9 ¹ / ₄	1 ⁵ / ₈	7 ¹ / ₄	1/8	7 ¹ / ₄	41.28	9,690	206.4	145
200	6	R2006C	247.7	11 ¹ / ₂	17 ¹ / ₂	9 ¹ / ₄	1 ⁵ / ₈	7 ¹ / ₄	1/8	7 ¹ / ₄	41.28	9,690	206.4	221
280	2	R2802C	113.5	7 ¹ / ₂	9 ¹ / ₂	10 ¹ / ₄	1 ⁵ / ₈	8 ¹ / ₂	1/8	8 ¹ / ₂	56.74	9,870	283.7	201
280	6	R2806C	340.4	11 ¹ / ₂	17 ¹ / ₂	10 ¹ / ₈	1 ⁵ / ₈	8 ¹ / ₂	1/8	8 ¹ / ₂	56.74	9,870	283.7	300
355	2	R3552C	141.8	9 ¹ / ₈	11 ¹ / ₈	11 ³ / ₄	2 ¹ / ₈	9 ¹ / ₂	1/8	9 ¹ / ₂	70.88	10,017	354.4	302
355	6	R3556C	425.3	13 ¹ / ₈	19 ¹ / ₈	11 ³ / ₄	2 ¹ / ₈	9 ¹ / ₂	1/8	9 ¹ / ₂	70.88	10,017	354.4	434
355	10	R35510C	708.8	17 ¹ / ₈	27 ¹ / ₈	11 ³ / ₄	2 ¹ / ₈	9 ¹ / ₂	1/8	9 ¹ / ₂	70.88	10,017	354.4	565
430	2	R4302C	173.2	10 ³ / ₈	12 ³ / ₈	13	2 ¹ / ₂	10 ¹ / ₂	1/8	10 ¹ / ₂	86.59	9,932	433.0	440
430	6	R4306C	519.5	14 ³ / ₈	20 ³ / ₈	13	2 ¹ / ₂	10 ¹ / ₂	1/8	10 ¹ / ₂	86.59	9,932	433.0	609
565	2	R5652C	226.2	11 ¹ / ₂	13 ¹ / ₂	14 ⁷ / ₈	2 ³ / ₄	12	1/8	12	113.10	9,991	565.5	638
565	6	R5656C	678.6	15 ¹ / ₂	21 ¹ / ₂	14 ⁷ / ₈	2 ³ / ₄	12	1/8	12	113.10	9,991	565.5	858
565	10	R56510C	1131.0	19 ¹ / ₂	29 ¹ / ₂	14 ⁷ / ₈	2 ³ / ₄	12	1/8	12	113.10	9,991	565.5	1078

For use with “RC” cylinders

Use with Cyl. No.	Swivel Cap Order No.	Wt. (lbs.)
150-200 ton	420867	8.8
280 ton	420868	13.5
355 ton	420869	37
430 ton	420870	52
565 ton	420871	78

SWIVEL CAPS
Reduce the effects of off center loading. Tilts up to 5 degrees. Radial grooves on top of cap reduce load slippage.

A (in.)	B (in.)
1 ¹ / ₂	5 ¹ / ₈
1 ³ / ₄	5 ⁷ / ₈
2 ³ / ₄	7 ¹¹ / ₁₆
3 ¹ / ₈	8 ⁷ / ₈
3 ⁵ / ₈	9 ⁷ / ₈

Reduce the effects of off-center loading. Tilts up to 5 degrees. Radial grooves on top of cap reduce load slippage. Notch across face of each cap helps keep loads having a protruding or round shaped centered.

26

POWER TEAM

HIGH TONNAGE

RC Series

740 - 1220 Ton

Single-Acting, Load Return

HIGH-TONNAGE, LOW CYCLE, GRAVITY RETURN.

- Overflow port ("weep hole") prevents piston from being overextended under load.
- Alloy heat treated piston and body for reliability and strength.
- Plated piston rod increases corrosion resistance and gives superior bearing support.



CYLINDERS

Single-Acting High Tonnage Cylinders

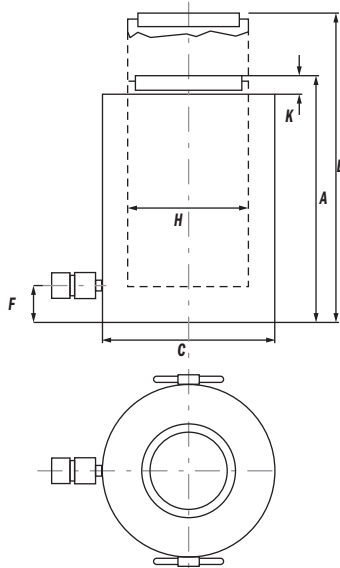

Swivel Cap

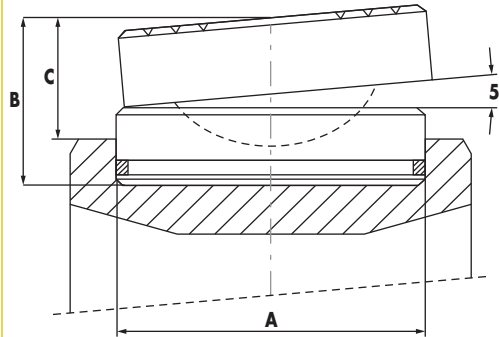

Order No.	Used with Cyl. Order No.	A in.	B in.	C in.	Product Wt. lbs.
2000824	RC740*C, RC965*C,	11.4	5.5	3.9	158.7
2000825	RC1220*C	12.7	6.9	4.9	249.1

In mm Cyl. Cap. (tons)	Stroke (in.)	Order No. (Cu. in.)	Oil Cap. (in.)	A Retracted Height (in.)	B Extended Height (in.)	C Outside Dia. (in.)	F Base to Port (in.)	Piston Rod Dia. (in.)	H Piston Rod Protrusion (in.)	K Bore Dia. (in.)	Cyl. Effective Area (cu. in.)	Tons @ 10,000 psi	Product Wt. (lbs.)
740	2.0	RC7402C	293.6	10.4	12.4	16.9	2.6	13.8	0.4	13.8	149.1	742	661
740	6.0	RC7406C	880.7	14.4	20.3	16.9	2.6	13.8	0.4	13.8	149.1	742	917
740	10	RC74010C	1,467.8	18.3	28.1	16.9	2.6	13.8	0.4	13.8	149.1	742	1,168
965	2.0	RC9652C	383.2	11.4	13.4	19.3	2.8	15.7	0.4	15.7	194.8	970	933
965	6.0	RC9656C	1,150.2	15.4	21.3	19.3	2.8	15.7	0.4	15.7	194.8	970	1,272
965	10	RC96510C	1,916.2	19.3	29.1	19.3	2.8	15.7	0.4	15.7	194.8	970	1,598
1220	2.0	RC12202C	485.1	16.3	18.1	21.7	3.1	17.7	0.4	17.7	246.5	1227	1,689
1220	6.0	RC12206C	1,455.8	20.2	26.1	21.7	3.1	17.7	0.4	17.7	246.5	1227	2,116
1220	10	RC122010C	2,452.2	24.4	34.2	21.7	3.1	17.7	0.4	17.7	246.5	1227	2,529

HIGH TONNAGE

R Series

100-565 Ton

Double-Acting, Hydraulic-Return



CYLINDERS

HIGH-TONNAGE, LOW CYCLE, HYDRAULIC RETURN.

- Cylinders come standard with swivel caps to reduce the effects of off-center loading.
- Cylinders may be "dead-ended" without damage.
- Hard chrome plated, heat treated piston rod reduces wear on piston and gland nut.
- Built-in safety relief valve prevents over-pressurization of the retract circuit.
- Each cylinder has two 9796 3/8" NPTF female half couplers.



R2806D

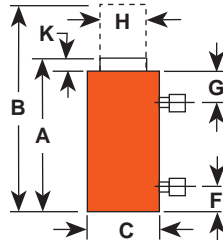

R1502D

Cyl. Cap. (tons)	Stroke (in.)	Order No.	Oil Capacity (cu. in.)		A Re-tracted Height (in.)	B Ex-tended Dia. (in.)	C Outside Dia. (in.)	F Base to Port (in.)	G Cylinder Top to Dia. (in.)	H Piston Rod Dia. (in.)	K Piston Rod Protrusion (in.)	Bore Dia. (in.)	Effective Area (sq. in.)	Internal Press. at Cap. (psi)	Tons at 10,000 psi	Prod. Wt. (lbs.)
			Push	Return												
100	2	R1002D	41.2	19.2	6 ^{41/64}	8 ^{41/64}	6 ^{1/2}	1	2 ^{13/64}	3 ^{3/4}	9 ^{9/32}	5 ^{1/8}	20.60	9,695	103.0	54
100	6	R1006D	123.6	57.6	10 ^{41/64}	16 ^{41/64}	6 ^{1/21}	1	2 ^{13/64}	3 ^{3/4}	9 ^{9/32}	5 ^{1/8}	20.60	9,695	103.0	81
100	10	R10010D	206.0	96.0	14 ^{41/64}	24 ^{41/64}	6 ^{1/2}	1	2 ^{13/64}	3 ^{3/4}	9 ^{9/32}	5 ^{1/8}	20.60	9,695	103.0	108
150	2	R1502D	61.4	29.6	7 ^{7/16}	9 ^{7/16}	8 ^{1/16}	1 ^{1/4}	2 ^{1/4}	4 ^{1/2}	19 ^{9/64}	6 ^{1/4}	30.70	9,778	153.4	95
150	6	R1506D	184.2	88.8	11 ^{7/16}	17 ^{7/16}	8 ^{1/16}	1 ^{1/4}	2 ^{1/4}	4 ^{1/2}	19 ^{9/64}	6 ^{1/4}	30.70	9,778	153.4	136
200	2	R2002D	82.6	39.2	8 ^{9/64}	10 ^{9/64}	9 ^{1/4}	1 ^{5/8}	2 ^{5/16}	5 ^{1/4}	11 ^{1/32}	7 ^{1/4}	41.30	9,690	206.4	136
200	6	R2006D	247.8	117.6	12 ^{9/64}	18 ^{9/64}	9 ^{1/4}	1 ^{5/8}	2 ^{5/16}	5 ^{1/4}	11 ^{1/32}	7 ^{1/4}	41.30	9,690	206.4	187
200	10	R20010D	413.0	196.0	16 ^{9/64}	26 ^{9/64}	9 ^{1/4}	1 ^{5/8}	2 ^{5/16}	5 ^{1/4}	11 ^{1/32}	7 ^{1/4}	41.30	9,690	206.4	239
280	2	R2802D	113.4	47.2	9 ^{13/64}	11 ^{13/64}	10 ^{7/8}	1 ^{7/8}	2 ^{37/64}	6 ^{1/2}	13 ^{1/32}	8 ^{1/2}	56.70	9,870	283.7	219
280	6	R2806D	340.2	141.6	13 ^{13/64}	19 ^{13/64}	10 ^{7/8}	1 ^{7/8}	2 ^{37/64}	6 ^{1/2}	13 ^{1/32}	8 ^{1/2}	56.70	9,870	283.7	297
280	10	R28010D	567.0	236.0	17 ^{13/64}	27 ^{13/64}	10 ^{7/8}	1 ^{7/8}	2 ^{37/64}	6 ^{1/2}	13 ^{1/32}	8 ^{1/2}	56.70	9,870	283.7	376
355	2	R3552D	141.8	47.4	11 ^{3/8}	13 ^{3/8}	11 ^{3/4}	2 ^{3/8}	2 ^{3/4}	7 ^{3/4}	7 ^{7/16}	9 ^{1/2}	70.90	10,017	354.4	324
355	6	R3556D	425.4	142.2	15 ^{3/8}	21 ^{3/8}	11 ^{3/4}	2 ^{3/8}	2 ^{3/4}	7 ^{3/4}	7 ^{7/16}	9 ^{1/2}	70.90	10,017	354.4	421
430	2	R4302D	173.2	59.6	12 ^{5/16}	14 ^{5/16}	13	2 ^{1/2}	2 ^{61/64}	8 ^{1/2}	15 ^{1/32}	10 ^{1/2}	86.60	9,932	433.0	439
430	6	R4306D	519.6	178.8	16 ^{5/16}	22 ^{5/16}	13	2 ^{1/2}	2 ^{61/64}	8 ^{1/2}	15 ^{1/32}	10 ^{1/2}	86.60	9,932	433.0	558
430	10	R43010D	866.0	298.0	20 ^{5/16}	30 ^{5/16}	13	2 ^{1/2}	2 ^{61/64}	8 ^{1/2}	15 ^{1/32}	10 ^{1/2}	86.60	9,932	433.0	673
565	2	R5652D	226.2	76.8	13 ^{19/32}	15 ^{19/32}	14 ^{7/8}	2 ^{3/4}	3 ^{13/64}	9 ^{3/4}	35 ^{5/64}	12	113.10	9,991	565.5	619
565	6	R5656D	678.6	230.4	17 ^{19/32}	23 ^{19/32}	14 ^{7/8}	2 ^{3/4}	3 ^{13/64}	9 ^{3/4}	35 ^{5/64}	12	113.10	9,991	565.5	772
565	10	R56510D	1131.0	384.0	21 ^{19/32}	31 ^{19/32}	14 ^{7/8}	2 ^{3/4}	3 ^{13/64}	9 ^{3/4}	35 ^{5/64}	12	113.10	9,991	565.5	926

HIGH TONNAGE

RC Series

740 & 1220

Double-Acting, Hydraulic Return

HIGH TONNAGE CYLINDERS RUGGED AND RELIABLE

- Cylinders come standard with hardened caps.
- Cylinders may be “dead-ended” without damage.
- Safety relief valve prevents over-pressurization of the retract circuit.
- Each cylinder has two 9796 3/8" NPTF female half couplers.



CYLINDERS

Double-Acting High Tonnage Cylinders

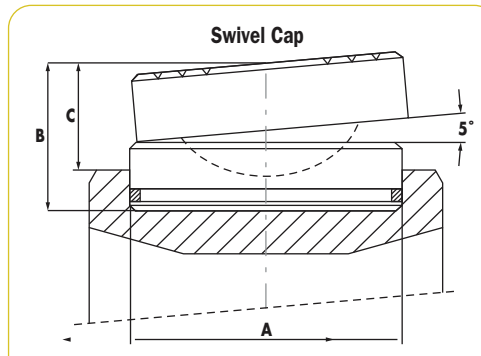
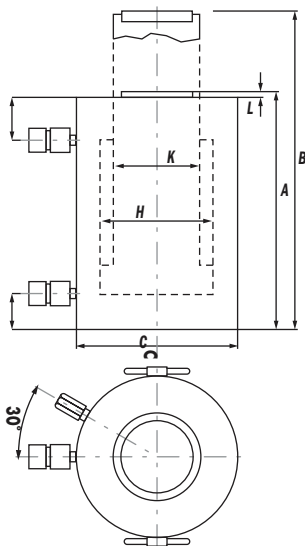

- **OPTIONAL SWIVEL CAPS REDUCE THE EFFECTS OF OFF-CENTER LOADING.**

Order No.	Used with Cyl. Order No.	A in.	B in.	C in.	Product Wt. lbs.
2000822	RC740*D	7.9	3.1	2.2	42.5
2000823	RC965*D	9.8	4.1	3.0	88.2
2000825	RC1220*D	12.7	6.9	4.9	249.1

In mm Cyl. Cap. (tons)	Stroke (in.)	Order No.	Oil Cap. (cu. in.)	A Retracted Height (in.)	B Extended Height (in.)	C Outside Dia. (in.)	F Base to Port (in.)	G Cyl. Top to Port (in.)	H Bore Dia. (in.)	K Piston Rod Dia. (in.)	L Piston Rod Protrusion (in.)	Cyl. Effective Area (cu. in.)	10,000 psi	Product Wt.
740	2.0	RC7402D	293.6	11.1	13.1	16.9	2.6	3.9	13.8	11.01	0.4	149.1	742	670
740	6	RC7406D	880.7	15.7	21.6	16.9	2.6	3.9	13.8	11.01	0.4	149.1	742	877
740	10	RC74010D	1,467.8	20.0	29.8	16.9	2.6	3.9	13.8	11.01	0.4	149.1	742	1080
965	2.0	RC9652D	383.2	12.2	14.2	19.3	2.8	4.5	15.7	14.17	0.4	194.8	970	957
965	6	RC9656D	1,150.2	16.5	22.4	19.3	2.8	4.5	15.7	14.17	0.4	194.8	970	1,215
965	10	RC96510D	1,916.2	20.9	30.7	19.3	2.8	4.5	15.7	14.17	0.4	194.8	970	1,473
1220	2.0	RC12202D	485.1	13.0	15.0	21.7	3.1	5.3	17.7	14.17	0.4	246.5	1227	1,287
1220	6	RC12206D	1,455.8	17.3	23.2	21.7	3.1	5.3	17.7	14.17	0.4	246.5	1227	1,612
1220	10	RC122010D	2,452.2	21.7	31.5	21.7	3.1	5.3	17.7	14.17	0.4	246.5	1227	1,936

LOCKING COLLAR

RL Series– Aluminum
55 & 100 Ton Single- Acting,
Spring-Return



CYLINDERS



Locking collar feature permits non-hydraulic support of load.



RA1006L



RA556L

ASME B30.1
10,000 PSI

POSITIVE MECHANICAL LOCK TO SUPPORT LOAD.

- Supports lifted load for extended periods of time with hydraulic pressure released.
- At half the weight of steel cylinders of comparable capacity, aluminum cylinders are ideal when portability is a key factor.
- Feature carrying handle.

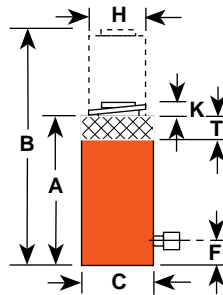

Cyl. Cap. (tons)	Order No.	Oil Cap. (cu. in.)	Stroke (in.)	Dimensions							Bore Dia. (in.)	Cylinder Effective Area (sq. in.)	Internal Pressure at Cap. (psi)	Tons at 10,000 psi	Product Wt. (lbs.)
				A Retracted Ht. (in.)	B Extended Ht. (in.)	C Outside Dia. (in.)	F Base to Port (in.)	H Piston Rod Dia. (in.)	K Piston Rod Protrusion (in.)	T Nut Thickness (in.)					
55	RA556L	67.6	6 ⁷ / ₈	12 ¹ / ₂	18 ⁵ / ₈	5 ¹ / ₄	1 ³ / ₈	3 ¹ / ₄	1 ¹ / ₂	1 ¹ / ₂	3 ³ / ₄	11.04	9,960	55.2	29.6
100	RA1006L	129	6 ³ / ₄	13 ³ / ₈	19 ⁵ / ₈	7 ³ / ₈	1 ³ / ₁₆	4 ¹ / ₂	1 ¹ / ₄	1 ¹ / ₂	5 ¹ / ₈	20.62	9,696	103.1	64.0

Note: Supported loads not to exceed the rated capacity of the cylinders. Not intended to support additional dynamic loads, such as those applied by moving vehicles.

PANCAKE CYLINDERS

Locking Collar

RC Series 55 & 620 Ton
Single- Acting, Load-Return

POSITIVE MECHANICAL LOCK TO SUPPORT LOAD.

- Compact design - for use where space is limited.
- Locking collar designed to support lifted load for extended periods of time with hydraulic pressure released.
- Integral tilt saddle standard improves performance under side load.
- Overflow port (“weep hole”) prevents piston from being overextended under load.
- Special coating improves corrosion and abrasion resistance.
- Cylinders come standard with hardened swivel caps reducing the effects of off-center loading Single-Acting Locking Collar Cylinders.
- Equipped with 3/8" NPTF female half couplers.



CYLINDERS

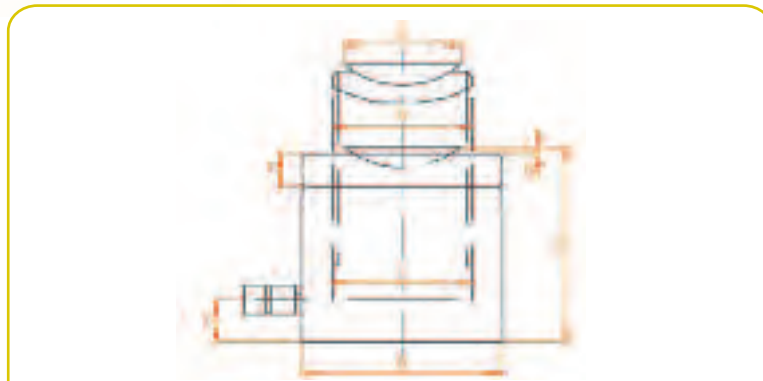

Cyl. Cap. (tons)	Stroke	Order No.	Oil Cap. (cm ³)	A Retracted Height (in.)	B Outside Dia. (in.)	C Piston Rod Dia. (in.)	D Bore Dia. (in.)	E Base to Port (in.)	F Nut Thickness (in.)	G Swivel Cap Protrusion (in.)	H Swivel Cap Dia. (in.)	Product Wt. (lbs.)
55	2	RC0552P	21.66	4.92	4.72	3.74	3.74	.75	.83	.24	3.62	24.25
100	1.75	RC1002P	36.43	5.39	6.5	5.12	5.12	.83	1.22	.31	4.96	48.50
155	1.75	RC1552P	55.23	5.83	8.07	6.30	6.30	1.06	1.50	.35	5.83	85.98
240	1.75	RC2402P	86.23	6.10	10.04	7.87	7.87	1.10	1.57	.39	6.18	130.07
380	1.75	RC3802P	134.74	7.01	12.60	9.84	9.84	1.38	1.97	.43	9.45	242.51
620	1.75	RC6202P	220.78	7.56	15.94	12.60	12.60	1.50	2.36	.39	11.61	425.49

LOCKING COLLAR

RL Series STEEL

55 -565 Ton

Single- Acting, Load-Return



CYLINDERS

POSITIVE MECHANICAL LOCK TO SUPPORT LOAD.

- Supports lifted load for extended periods of time with hydraulic pressure released.
- Visible indicator band alerts when stroke limit is reached; overflow port ("weep hole") stroke limiter prevents piston from being overextended.
- All cylinders feature coated pistons to resist corrosion and abrasion.



Locking collar feature permits non-hydraulic support of load.

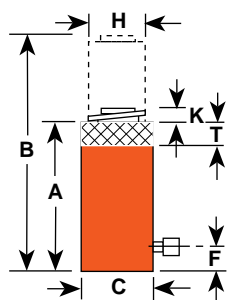

SWIVEL CAPS For use with "RL" cylinders
Reduce the effects of off center loading.
Tilts up to 5 degrees. Radial grooves on top of cap reduce load slippage.

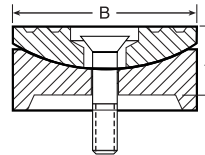

A (in.)	B (in.)	Use with Cyl. No.	Swivel Cap Order No.	Wt. (lbs.)
1	2 ¹³ / ₁₆	55-100 ton	420866	1.8
1 ¹ / ₂	5 ¹ / ₈	150-200 ton	420867	8.8
1 ³ / ₄	5 ⁷ / ₈	280 ton	420868	13.5
2 ³ / ₄	7 ¹¹ / ₁₆	355 ton	420869	37
3 ¹ / ₈	8 ⁷ / ₈	430 ton	420870	52
3 ⁵ / ₈	9 ⁷ / ₈	565 ton	420871	78

Cyl. Cap. (tons)	Stroke (in.)	Order No.	Oil Cap. (cu. in.)	A	B	C	F	H	K	T	Bore Dia. (in.)	Cylinder Effective Area (sq. in.)	Internal Pressure at Cap. (psi)	Tons at 10,000 psi	Product Wt. (lbs.)
				Retracted Ht. (in.)	Extended Ht. (in.)	Outside Dia. (in.)	Base to Port (in.)	Piston Rod Dia. (in.)	Piston Rod Protrusion (in.)	Nut Thickness (in.)					
55	2	R552L	22.10	6 ³ / ₈	8 ³ / ₈	4 ¹⁵ / ₁₆	1	3 ³ / ₄	1 ¹ / ₈	1 ⁷ / ₁₆	3 ³ / ₄	11.04	9,964	55.2	33.7
55	6	R556L	66.30	10 ³ / ₈	16 ³ / ₈	4 ¹⁵ / ₁₆	1	3 ³ / ₄	1 ¹ / ₈	1 ⁷ / ₁₆	3 ³ / ₄	11.04	9,964	55.2	58.0
55	10	R5510L	110.40	14 ³ / ₈	24 ³ / ₈	4 ¹⁵ / ₁₆	1	3 ³ / ₄	1 ¹ / ₈	1 ⁷ / ₁₆	3 ³ / ₄	11.04	9,964	55.2	80.0
100	2	R1002L	41.30	7 ¹ / ₄	9 ¹ / ₄	6 ¹ / ₂	1	5 ¹ / ₈	1 ¹ / ₈	1 ³ / ₄	5 ¹ / ₈	20.63	9,695	103.0	66.0
100	6	R1006L	123.80	11 ¹ / ₄	17 ¹ / ₄	6 ¹ / ₂	1	5 ¹ / ₈	1 ¹ / ₈	1 ³ / ₄	5 ¹ / ₈	20.63	9,695	103.0	103.0
100	10	R10010L	206.30	15 ¹ / ₄	25 ¹ / ₄	6 ¹ / ₂	1	5 ¹ / ₈	1 ¹ / ₈	1 ³ / ₄	5 ¹ / ₈	20.63	9,695	103.0	142.0
150	2	R1502L	61.40	8 ¹ / ₈	10 ¹ / ₈	8 ¹ / ₁₆	1 ¹ / ₄	6 ¹ / ₄	1 ¹ / ₈	1 ³ / ₄	6 ¹ / ₄	30.68	9,778	153.4	117.0
150	6	R1506L	184.10	12 ¹ / ₈	18 ¹ / ₈	8 ¹ / ₁₆	1 ¹ / ₄	6 ¹ / ₄	1 ¹ / ₈	1 ³ / ₄	6 ¹ / ₄	30.68	9,778	153.4	177.0
200	2	R2002L	82.60	9 ¹ / ₂	11 ¹ / ₂	9 ¹ / ₄	1 ⁵ / ₈	7 ¹ / ₄	1 ¹ / ₈	2	7 ¹ / ₄	41.28	9,690	206.4	183.0
200	6	R2006L	247.70	13 ¹ / ₂	19 ¹ / ₂	9 ¹ / ₄	1 ⁵ / ₈	7 ¹ / ₄	1 ¹ / ₈	2	7 ¹ / ₄	41.28	9,690	206.4	259.0
280	2	R2802L	113.50	9 ³ / ₄	11 ³ / ₄	10 ⁷ / ₈	1 ⁵ / ₈	8 ¹ / ₂	1 ¹ / ₈	2 ¹ / ₄	8 ¹ / ₂	56.74	9,870	283.7	261.0
280	6	R2806L	340.40	13 ³ / ₄	19 ³ / ₄	10 ⁷ / ₈	1 ⁵ / ₈	8 ¹ / ₂	1 ¹ / ₈	2 ¹ / ₄	8 ¹ / ₂	56.74	9,870	283.7	359.0
280	10	R28010L	567.40	17 ³ / ₄	27 ³ / ₄	10 ⁷ / ₈	1 ⁵ / ₈	8 ¹ / ₂	1 ¹ / ₈	2 ¹ / ₄	8 ¹ / ₂	56.74	9,870	283.7	459.0
355	2	R3552L	141.80	11 ¹ / ₂	13 ¹ / ₂	11 ³ / ₄	2 ¹ / ₈	9 ¹ / ₂	1 ¹ / ₈	2 ³ / ₈	9 ¹ / ₂	70.88	10,017	354.4	381.0
355	6	R3556L	425.30	15 ¹ / ₂	21 ¹ / ₂	11 ³ / ₄	2 ¹ / ₈	9 ¹ / ₂	1 ¹ / ₈	2 ³ / ₈	9 ¹ / ₂	70.88	10,017	354.4	512.0
430	2	R4302L	173.20	13 ¹ / ₈	15 ¹ / ₈	13	2 ¹ / ₂	10 ¹ / ₂	1 ¹ / ₈	2 ³ / ₄	10 ¹ / ₂	86.59	9,932	433.0	556.0
430	6	R4306L	519.50	17 ¹ / ₈	23 ¹ / ₈	13	2 ¹ / ₂	10 ¹ / ₂	1 ¹ / ₈	2 ³ / ₄	10 ¹ / ₂	86.59	9,932	433.0	725.0
430	10	R43010L	865.90	21 ¹ / ₈	31 ¹ / ₈	13	2 ¹ / ₂	10 ¹ / ₂	1 ¹ / ₈	2 ³ / ₄	10 ¹ / ₂	86.59	9,932	433.0	894.0
565	2	R5652L	226.20	14 ⁵ / ₈	16 ⁵ / ₈	14 ⁷ / ₈	2 ³ / ₄	12	1 ¹ / ₈	3 ¹ / ₈	12	113.10	9,991	565.5	811.0
565	6	R5656L	678.60	18 ⁵ / ₈	24 ⁵ / ₈	14 ⁷ / ₈	2 ³ / ₄	12	1 ¹ / ₈	3 ¹ / ₈	12	113.10	9,991	565.5	1031.0
565	10	R56510L	1131.0	22 ⁵ / ₈	32 ⁵ / ₈	14 ⁷ / ₈	2 ³ / ₄	12	1 ¹ / ₈	3 ¹ / ₈	12	113.10	9,991	565.5	1251.0

•NOTE: Supported loads not to exceed the rated capacity of the cylinders. Not intended to support additional dynamic loads, such as those applied by moving vehicles.

LOCKING COLLAR

RC SERIES

740 & 1220

Single-Acting, Load Return

POSITIVE MECHANICAL LOCK TO SUPPORT LOAD.



CYLINDERS

Single-Acting Locking Collar Cylinders

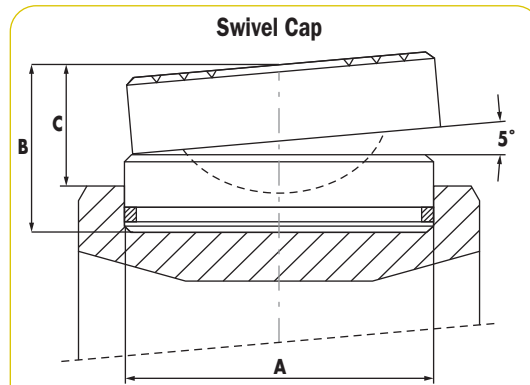
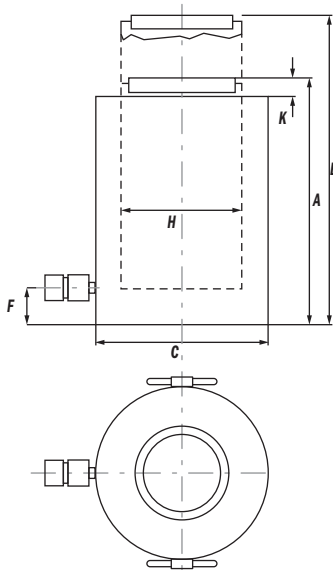

Order No.		A in.	B in.	C in.	Product Wt. lbs.
2000824	RC740*L, RC965*L	11.4	5.5	3.9	158.7
2000825	RC1220*L	12.7	6.9	4.9	249.1

Cyl. Cap. (tons)	Stroke (in.)	Order No.	Oil Cap. (Cu. in.)	A Retracted Height (in.)	B Extended Height (in.)	C Outside Dia. (in.)	F Base to Port (in.)	H Piston Rod Dia. (in.)	K Piston Rod Protrusion (in.)	Bore Dia. (in.)	Cyl. Effective Area (in.)	Tons @ 10,000 psi	Product Wt. (lbs)
740	2.0	RC7402L	293.6	15.6	17.6	18.7	3.5	TR13.8X6	0.2	13.8	149.1	742	1,202
740	6.0	RC7406L	880.7	19.5	25.4	18.7	3.5	TR13.8X6	0.2	13.8	149.1	742	1,506
740	10.0	RC74010L	1,467.8	23.4	33.2	18.7	3.5	TR13.8X6	0.2	13.8	149.1	742	1,810
965	2.0	RC9652L	383.2	17.9	19.9	21.3	3.9	TR15.7X6	0.2	15.7	194.8	970	1,574
962	6.0	RC9656L	1,150.2	21.9	27.8	21.3	3.9	TR15.7X6	0.2	15.7	194.8	970	2,183
962	10.0	RC96510L	1,916.2	25.8	35.6	21.3	3.9	TR15.7X6	0.2	15.7	194.8	970	2,579
1220	2.0	RC12202L	485.1	17.4	19.4	23.6	4.3	TR17.7X6	0.2	17.7	246.5	1227	2,136
1220	6.0	RC12206L	1,455.8	23.5	29.4	23.6	4.3	TR17.7X6	0.2	17.7	246.5	1227	2,888
1220	10.0	RC122010L	2,452.2	27.5	37.3	23.6	4.3	TR17.7X6	0.2	17.7	246.5	1227	3,373

ACCESSORIES

C Series

Mounting accessories



CYLINDERS



Threaded Connector

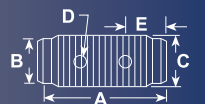

Cylinder Tons	Part No.	A	B	C	D	E
5	25748	1 ³ / ₄	7/8 Dia.	3/4 — 14 NPSM	3/16 Dia.	1/2
10	25664	1 ⁵ / ₈	1 ⁷ / ₁₆ Dia.	1 ¹ / ₄ — 11 ¹ / ₂ NPSM	5/16 Dia.	9/16
25	25654	2 ¹ / ₄	2 ¹ / ₈ Dia.	2 — 11 ¹ / ₂ NPSM	3/8 Dia.	5/8



Piston Clevis

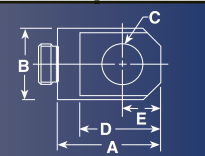

Cylinder Tons	Part No.	A	B	C	D	E	F
5	350095	1 ³ / ₄	1 ¹ / ₈	5/8	17/16	5/8	3/4-16
10 or 15*	350094	2 ⁹ / ₁₆	1 ¹¹ / ₁₆	7/8	2 ⁵ / ₁₆	1	1-8
25**	420059	2 ¹⁵ / ₁₆	2 ¹ / ₄	1 ¹ / ₄	2 ¹¹ / ₁₆	1 ¹ / ₄	1 ¹ / ₂ -16

* Can be used with RD106, RD1010 Cylinder.

** RD256 & RD2514

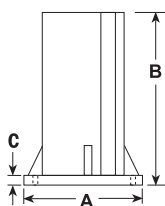

Support Base

Cylinder	Order	A	B	C
10	420062	7	5	7/16
25	420063	7	5	7/16



Threaded Adapter Plain Adapter

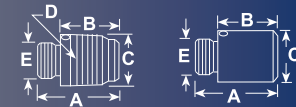

Cylinder Tons	Part No.	A	B	C	D	E
5	202178 (threaded)	1 ⁵ / ₈	1 ¹ / ₈	1 ¹ / ₁₆ Dia.	3/4 — 14 NPT	3/4 — 16 UNF-2A
10 or 15	202179 (threaded)	1 ¹³ / ₁₆	1 ¹ / ₁₆	1 ⁵ / ₈ Dia.	1 ¹ / ₄ — 11 ¹ / ₂ NPT	1 — 8 UNC-2A
25	202180 (threaded)	2 ³ / ₄	1 ⁷ / ₈	2 ³ / ₈ Dia.	2 — 11 ¹ / ₂ NPT	1 ¹ / ₂ — 16 UN-2A
10 or 15	350724 (plain)	2	1 ¹ / ₄	1 ³¹ / ₆₄ Dia.	—	1 — 8 UNC-2A
25	350723 (plain)	2 ¹ / ₈	1 ¹ / ₄	2 ¹ / ₄ Dia.	—	1 ¹ / ₂ — 16 UN-2A

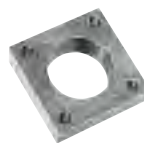

Cylinder Mounting Plate

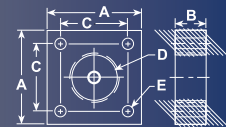

Cylinder Tons	Part No.	A	B	C	D	E
5	350099	3	1	2 ¹ / ₈	1 ¹ / ₂ — 16 UN-2B	1 ¹¹ / ₃₂
10	350100	3 ¹ / ₂	1	2 ⁵ / ₈	2 ¹ / ₄ — 14 UNS-2B	1 ¹¹ / ₃₂
15	350184	3 ¹ / ₂	1	2 ⁵ / ₈	2 ³ / ₄ — 16 UN-2B	1 ¹¹ / ₃₂
25	420064	5	2	3 ²¹ / ₃₂	3 ⁵ / ₁₆ — 12 UN-2B	2 ¹ / ₃₂

Extension Rod

Cylinder Tons	Part No.	A	B	C	D	E
5	350895	5	7/8 Dia.	3/4 — 14 NPT	21/64 Dia.	2
5	38908	10	7/8 Dia.	3/4 — 14 NPT	21/64 Dia.	2
5	350896	18	7/8 Dia.	3/4 — 14 NPT	21/64 Dia.	2
10	350897	5	17/16 Dia.	1 1/4 — 11 1/2 NPT	21/64 Dia.	2
10	38909	10	17/16 Dia.	1 1/4 — 11 1/2 NPT	21/64 Dia.	2
10	350898	18	17/16 Dia.	1 1/4 — 11 1/2 NPT	21/64 Dia.	2

Cylinder Base Attachment

Cylinder Tons	Part No.	A	B	C	D
5	208380	1 5/8	1 3/4 Dia.	3/4 14 NPSM	9/32 Dia. (2) 1/4 — 20 UNC x 3/4 Lg. Socket Head Cap Screws
10	208381	1 7/8	2 1/2 Dia.	1 1/4 — 11 1/2 NPSM	11/32 Dia. (2) 5/16 — 18 UNC x 3/4 Lg. Socket Head Cap Screws
25	208382	2 3/8	3 3/8 Dia.	2 — 11 1/2 NPSM	17/32 Dia. (2) 1/2 — 13 UNC x 1 Lg. Socket Head Cap Screws

Cylinder Flat Base

Cylinder Tons	Part No.	A	B	C	D
5	25750 *	4 1/2	2 1/2	3/4 — 14 NPSM	1 11/32
10	32325 *	6 9/16	3 1/2	1 1/4 — 11 1/2 NPSM	1 7/16

Smooth Saddle Serrated Saddle

Cylinder Tons	Part No.	A	B	C
5	25746 *(serrated)	1 1/8	1 5/16 Dia.	3/4 — 14 NPSM
10 or 15	31772 *(serrated)	1 1/8	2 Dia.	1 1/4 — 11 1/2 NPSM
25	31776 *(serrated)	1 5/16	3 Dia.	2 — 11 1/2 NPSM
5	351575 *(plain)	1 1/8	1 5/16 Dia.	3/4 — 14 NPSM
10	24016 *(plain)	1 1/8	2 Dia.	1 1/4 — 11 1/2 NPSM
25	351576 *(plain)	1 5/16	3 Dia.	2 — 11 1/2 NPSM

Body Clevis†

Cylinder Tons	Part No.	A	B	C	D	E	F
5	350096	2 1/16	1 1/8	5/8	5/8	9/16	1/4
10	350097	3	1 11/16	7/8	1	1	1/4
15	350098	3 1/16	1 11/16	7/8	1	1	1/4
25	420061	3 9/16	2 1/4	1 1/4	1 1/4	1 1/2	1/4

Swivel Cap

Cylinder Tons	Part No.	A	B
10 or 15	350144	7/8	1 3/8
25	350145	1 1/8	2
55 or 75	350376	1 1/4	2 13/16
100	351574	1 29/32	3 15/32

90° "V" Base

Cylinder Tons	Part No.	A	B	C
5	25388 * 1 3/8	1 1/16	3/4 — 14 NPSM	
10	25395 * 2 1/8	2 1/8	1 1/4 — 11 1/2 NPSM	

Plunger Base

Cylinder Tons	Part No.	A	B	C
25	25652	6	1 1/4	2 — 11 1/2 NPSM

* Items require threaded adapter (Page 36) when used with "C" series cylinders. They may be used on threaded "CBT" cylinders without the use of an adapter.
 † Mounting screws are included.



ACCESSORIES

Swivel Caps Center Hole Accessories

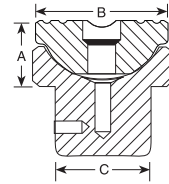
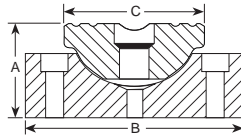

CYLINDERS

Use with Cyl. No.		Swivel Cap Order No.	Wt. (lbs.)	A (in.)	B (in.)	C (in.)
RSS101		350320	0.5	1	1 ⁷ / ₁₆	1 ⁷ / ₁₆
RSS202		350321	1.3	1 ³ / ₈	2 ¹ / ₈	2 ¹ / ₈
RSS302		350322	1.6	1 ³ / ₈	2 ¹ / ₂	2 ¹ / ₈
RSS502		350331	2.7	1 ⁷ / ₁₆	3 ¹ / ₄	2 ¹ / ₈
RSS1002		350332	6.6	1 ¹³ / ₁₆	4 ³ / ₈	3 ³ / ₈
Tonnage		"RA" CYLINDERS				
55		350376	2	1 ¹ / ₄	2 ¹³ / ₁₆	2 ¹³ / ₁₆
100		350984	5.6	1 ¹⁵ / ₁₆	3 ¹ / ₈	3 ³ / ₄

Cylinder Tonnage	Swivel Cap Order No.	Prod.			
		Wt. (lbs.)	A (in.)	B (in.)	C (in.)
10	350144	0.8	7/8	1 ⁷ / ₁₆	5 ⁵ / ₆₄
25	350145	1.3	1 ¹ / ₈	2 ¹ / ₈	1 ⁷ / ₁₆
55	351325	4.2	2 ⁷ / ₁₆	2 ¹ / ₂	1 ³⁵ / ₆₄
100	351324	11.2	2 ⁶¹ / ₆₄	3 ³ / ₄	2 ²¹ / ₃₂
150	351334	12.8	2 ⁵ / ₈	4 ³ / ₈	3 ¹ / ₁₆

For use with "RC" cylinders			SWIVEL CAPS Reduce the effects of off center loading. Tilts up to 5 degrees. Radial grooves on top of cap reduce load slippage.				For use with "RL" cylinders		
Use with Cyl. No.	Swivel Cap Order No.	Wt. (lbs.)	A (in.)	B (in.)	A (in.)	B (in.)	Use with Cyl. No.	Swivel Cap Order No.	Wt. (lbs.)
150-200 ton	420867	8.8	1 ¹ / ₂	5 ¹ / ₈	1	2 ¹³ / ₁₆	55-100 ton	420866	1.8
280 ton	420868	13.5	1 ³ / ₄	5 ⁷ / ₈	1 ¹ / ₂	5 ¹ / ₈	150-200 ton	420867	8.8
355 ton	420869	37	2 ³ / ₄	7 ¹¹ / ₁₆	1 ³ / ₄	5 ⁷ / ₈	280 ton	420868	13.5
430 ton	420870	52	3 ¹ / ₈	8 ⁷ / ₈	2 ³ / ₄	7 ¹¹ / ₁₆	355 ton	420869	37
565 ton	420871	78	3 ⁵ / ₈	9 ⁷ / ₈	3 ¹ / ₈	8 ⁷ / ₈	430 ton	420870	52
					3 ⁵ / ₈	9 ⁷ / ₈	565 ton	420871	78

Reduce the effects of off-center loading. Tilts up to 5 degrees. Radial grooves on top of cap reduce load slippage. Notch across face of each cap helps keep loads having a protruding or round shaped centered.

		"CENTER-HOLE" CYLINDER ACCESSORIES			
To use with Cyl. No.		RT172, RH203	RT302, RH302 RH303, RH306	RT503, RH503, RH603 RH605, RH606	RT1004
Order Set No.		RHA20	RHA30	RHA50	RHA100
	1 Speed Crank	1 24814	27198	29595	303785
	2 Speed Nut	2 302482	302483	33439	34136
	3 Adjusting Screw	3 32118	34758	32698	32699
	4 Threaded Insert	Order threaded insert for RH series cylinders with the accessory set. (See page 39). Threaded insert supplied with RT series cylinders			
	5 Pushing Adapter	5 201923	34510	34755	—
	Pushing Adapter	6 201454	34511	34756	—
	Jack Screw	7 24813	25931	32701	32702
	Screw Cap	8 28228	28229	28230	—

ACCESSORIES

Seal Kits

Cylinder Order No.	Seal Kit*	Viton Seal Kit
C51C	300404	300210
C53C	300404	300210
C55C	300404	300210
C57C	300404	300210
C59C	300404	300210
C101C	300116	300211
C102C	300116	300211
C104C	300116	300211
C106C	300116	300211
C108C	300116	300211
C1010C	300116	300211
C1012C	300116	300211
C1014C	300116	300211
C1016C	300116	300211
C151C	300453	300471
C152C	300453	300471
C154C	300453	300471
C156C	300453	300471
C158C	300453	300471
C1510C	300453	300471
C1512C	300453	300471
C1514C	300453	300471
C1516C	300453	300471
C251C	300147	300213
C252C	300147	300213
C254C	300147	300213
C256C	300147	300213
C258C	300147	300213
C2510C	300147	300213
C2512C	300147	300213
C2514C	300147	300213
C552C	300114	300215
C554C	300114	300215
C556C	300114	300215
C5510C	300114	300215
C5513C	300114	300215
C756C	300647	300846
C7513C	300647	300846
C1002C	300112	300216
C1006C	300112	300216
C10010C	300112	300216
C55CBT	300404	300210
C106CBT	300116	300211
C1010CBT	300116	300211
C256CBT	300147	300213
C2514CBT	300147	300213
R1502C	300676	—
R1506C	300676	—
R15010C	300676	—
R2002C	300677	—
R2006C	300677	—

Cylinder Order No.	Seal Kit*	Viton Seal Kit
R20010C	300677	—
R2802C	300678	—
R2806C	300678	—
R28010C	300678	—
R3552C	300679	—
R3556C	300679	—
R35510C	300679	—
R4302C	300680	—
R4306C	300680	—
R43010C	300680	—
R5652C	300681	—
R5656C	300681	—
R56510C	300681	—
R1002D	300928	—
R1006D	300928	—
R10010D	300928	—
R1502D	300929	—
R1506D	300929	—
R15010D	300929	—
R2002D	300930	—
R2006D	300930	—
R20010D	300930	—
R2802D	300931	—
R2806D	300931	—
R28010D	300931	—
R3552D	300932	—
R3556D	300932	—
R35510D	300932	—
R4302D	301047	—
R4306D	301047	—
R43010D	301047	—
R5652D	300934	—
R5656D	300934	—
R56510D	300934	—
R552L	300674	—
R556L	300674	—
R5510L	300674	—
R1002L	300675	—
R1006L	300675	—
R10010L	300675	—
R1502L	300676	—
R1506L	300676	—
R15010L	300676	—
R2002L	300677	—
R2006L	300677	—
R20010L	300677	—
R2802L	300678	—
R2806L	300678	—
R28010L	300678	—
R3552L	300679	—
R3556L	300679	—

Cylinder Order No.	Seal Kit*	Viton Seal Kit
R35510L	300679	—
R4302L	300680	—
R4306L	300680	—
R43010L	300680	—
R5652L	300681	—
R5656L	300681	—
R56510L	300681	—
RA202	300631	—
RA204	300631	—
RA206	300631	—
RA302	300632	—
RA304	300632	—
RA306	300632	—
RA552	300391	—
RA554	300391	—
RA556	300391	—
RA5510	300391	—
RA1002	300444	—
RA1006	300444	—
RA556L	300395	—
RA1006L	300396	—
RD106	300017	—
RD1010	300017	—
RD256	300118	—
RD2514	300118	—
RD556	300005	—
RD5513	300005	—
RD5518	300005	—
RD8013	300410	—
RD1006	300006	—
RD10013	300006	—
RD10020	300006	—
RD1506	300007	—
RD15013	300007	—
RD15018	300007	—
RD2006	300008	—
RD20013	300008	—
RD3006	300466	—
RD30013	300466	—
RD4006	300467	—
RD40013	300467	—
RD5006	300468	—
RD50013	300468	—
RH102	300071	300221
RH108	300071	300221
RH120	300657	—

Cylinder Order No.	Seal Kit*	Viton Seal Kit
RH121	300576	—
RH121T	300576	—
RH123	300576	—
RH202	300615	—
RH203	300069	300222
RH206	300615	—
RH302	300037	300223
RH306	300037	300223
RH503	300059	300225
RH603	300477	300476
RH606	300477	300476
RH1003	300485	300585
RH303	300077	300224
RH306D	300822	300224
RH3010	300625	—
RH605	300269	300226
RH6010	300626	—
RH1001	300927	—
RH1006	300295	300227
RH10010	300629	—
RH1505	300154	300228
RH1508	300583	—
RH2008	300582	—
RHA306	300867	300868
RHA604D	300269	300226
RLS50	300454	—
RLS100	300455	—
RLS200	300456	—
RLS300	300457	—
RLS500S	300458	—
RLS750S	300459	—
RLS1000S	300460	—
RLS1500S	300461	—
RP25	300628	—
RP55	300627	—
RSS101	300010	—
RSS202	300011	—
RSS302	300297	—
RSS502	300292	—
RSS1002	300293	—
RSS2503	—	—
RSS1002D	300578	—
RT172	300358	—
RT302	300359	—
RT503	300360	—
RT1004	300024	—



CYLINDERS

ACCESSORIES

Cribbing Blocks



CYLINDERS

Convert Power Team “Shorty” cylinders to mechanical cribbing devices; more stable than timber or other awkward, makeshift methods. Ideal for lifting applications such as structure moving. Reduces cribbing time dramatically. In effect, increases the stroke of the cylinder; stacking pads act as cylinder extensions:

1. Extend cylinder and insert lower supporting ring.
2. Retract cylinder, insert a stacking pad.
3. Extend cylinder again; pad increases cylinder stroke.
4. Repeat process until all rings and pads are used.

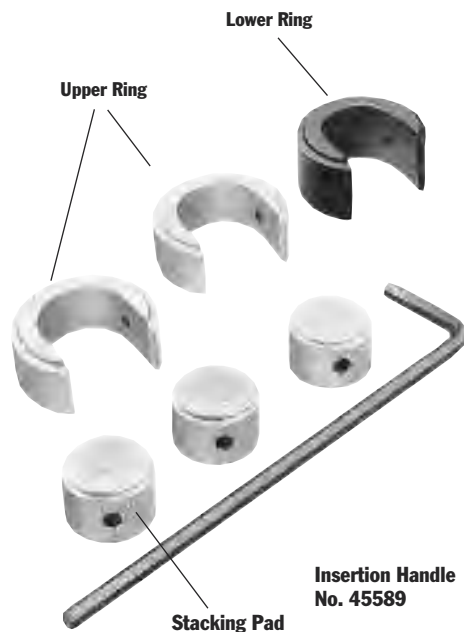

Each cribbing block set includes rings, pads and insertion handle.

- No. CB30** — Cribbing block set for use with No. RSS302; 30 ton cylinder.
- No. CB50** — Cribbing block set for use with No. RSS502; 50 ton cylinder.
- No. CB100** — Cribbing block set for use with No. RSS1002; 100 ton cylinder.
- No. 45589** — Insertion handle is used for inserting rings and pads.

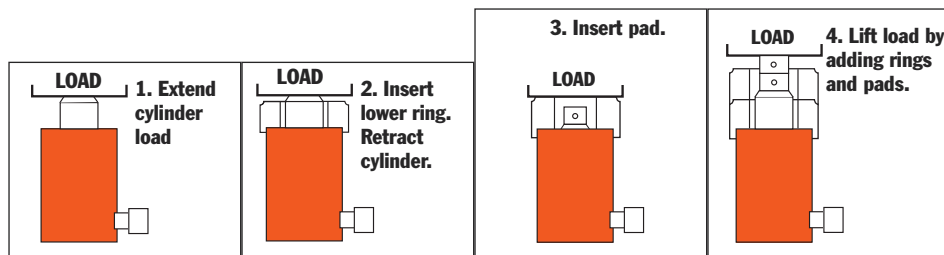

FOR USE WITH ORDER NUMBER	30 TON CYLINDER NO. RSS302 30 TON SET NO. CB30			50 TON CYLINDER NO. RSS502 50 TON SET NO. CB50			100 TON CYLINDER NO. RSS1002 100 TON SET NO. CB100		
	Lower Ring	Upper Ring	Stacking Pad	Lower Ring	Upper Ring	Stacking Pad	Lower Ring	Upper Ring	Stacking Pad
No. included in set	1	2	3	1	2	3	1	3	4
Outside Diameter (in.)	4 ¹ / ₂	4 ¹ / ₂	2 ³ / ₄	5 ¹ / ₂	5 ¹ / ₂	3 ³ / ₈	7 ²⁵ / ₆₄	7 ²⁵ / ₆₄	4 ³ / ₄
Inside Diameter (in.)	2 ¹³ / ₁₆	2 ¹³ / ₁₆	—	3 ²⁹ / ₆₄	3 ²⁹ / ₆₄	—	4 ¹³ / ₁₆	4 ¹³ / ₁₆	—
Height, each (in.)	2 ⁹ / ₃₂	1 ⁵¹ / ₆₄	1 ²⁵ / ₃₂	2 ⁷ / ₃₂	1 ²³ / ₃₂	1 ¹¹ / ₁₆	2 ¹ / ₈	1 ³ / ₄	1 ²³ / ₃₂
Total stacked height of rings in Set (in.)		5 ⁷ / ₁₆			5 ³ / ₁₆			6 ⁷ / ₈	
Weight of Set (lbs.)		20			28			64	

Each set includes one Insertion Handle No. 45589 - 1/2" Hex. x 18" Long, 4" Bend



CYLINDER LIFTING HANDLE

No. 420655OR9	—	Lifting handle for “C” series, 25 ton cylinders.
No. 421312OR9	—	Lifting handle for RH302, RH303, RH306 and RH306D, cylinders.
No. 252215	—	Lifting handle RHA306, 30 ton cylinder.
No. 420496BK2	—	Lifting handle RA552 and RA554, 55 ton cylinders.
No. 420498BK2	—	Lifting handle RA1002, 100 ton cylinder.



ALUMINUM CYLINDER BASE

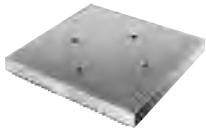

Aluminum Cylinder Base – For use when an enlarged cylinder base is needed or advantageous. Attaches to bottom of RA556, RA556L and RA5510 with four 3/8"-16 screws (included). Serrated base for extra stability.

No. 208406 – Aluminum cylinder base, 7" square. For use with RA556, RA556L and RA5510 cylinders.



HEAD INSERTS FOR RH SERIES CYLINDERS

For Use With:	Threaded Insert Order No.
RH102, RH108	28632 3/4"-16
RH203	28612 1"-8
RH302, RH306	38904 1 1/4"-7
RH303	28644 1 1/4"-7
RH503	38855 1 5/8"-5 1/2
RH603, RH605 RH606	34251 1 5/8"-5 1/2



Quick-Change Inserts

"QUICK CHANGE" HEAD INSERTS FOR RT SERIES CYLINDERS

For Use With:	Threaded Order No.*	Plain Order No.
RT172	21669	21714
RT302	21873	21872
RT503	22274	22275
RT1004	24197	24196

Switch from a tapped hole to a plain hole quickly with these cylinder head inserts. They are held in place with a socket screw. Plain hole permits use of a speed nut for readjusting cylinder after extension.

* Provided with cylinder

PUMPS

HIGH PERFORMANCE HIGH FORCE HYDRAULICS



PUMP BASICS...42



Page

P SERIES...46-48

Hand Pumps



Page

RPS SERIES...49

Cylinder and Pump Sets



Page

PA6...50-51

Air Hydraulic



Page

PA6D...52-53

Air Hydraulic



Page

PA9...54-55

Air Hydraulic



Page

PA60...56

Air Hydraulic



Page

PA50...58

Air Hydraulic



Page

PA17...60

Air Hydraulic



Page

PA46/55...62

Air Hydraulic



Page

PUA, PMA...64-67

Air Operated Pump



Page

PE10...68

Electric Battery



Page

PE17...70

Electric Hydraulic



Page

PE18...72

Vanguard Jr.
Electric Hydraulic



Page

PE21...74

Electric Hydraulic



Page

PED...76

Electric Hydraulic



Page

PE30...78

Vanguard®
Electric Hydraulic



Page

PE46...80

Electric Hydraulic



Page

VANGUARD...82

Electric Hydraulic



Page

PE60...84

Electric Hydraulic



Page

PQ60...86

Quiet Electric Hydraulic



Page

PQ120...88

Quiet Electric Hydraulic



Page

PE400...90

Electric Hydraulic



Page

PE-NUT...92

Electric Hydraulic



Page

PG30/55...94

Gasoline Driven



Page

PG120-PG400...96

Gasoline Driven



Page

INTENSIFIER...98



Page

X1A1-PT...99



Page

**ASSEMBLE ...100
TO ORDER PUMPS**



Page

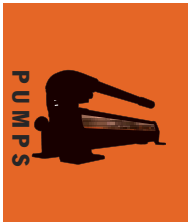

PUMP SELECTION

Choose the Right Pump



Step 1 – Select the hydraulic cylinder that best suits the application. See pages 6-8.

Step 2 – Select the series of hydraulic pump with adequate oil output and reservoir capacity to power cylinder. See page 45. Check speed/selection chart on page 6.

Step 3 – Select pump within series with the valve option that is best suited to the cylinder and application. See pages 120-121.

CONSIDERATIONS:

What maximum system operating pressure (psi) is required?

What volume of oil delivery is required? (For manual pumps, cu. in. of oil per handle stroke; for powered pumps, cu. in./min. of oil).

Is a single- or 2-speed pump required? (2-speed pumps deliver high oil volume at low pressure for rapid cylinder piston advance, then shift to the high pressure, low volume stage under load).

What is the preferred source of power?

- Manual (hand or foot operated). Provides portability, can be used where electricity or shop air are not available.
- Air/Hydraulic. Uses shop air or a portable air compressor.
- Electric /Hydraulic. What voltage is available? Is a battery operated pump preferred?
- Gasoline Engine/Hydraulic. Powers high-output pumps at remote job sites where air or electricity are unavailable.

Is portability of the pump a factor to consider?

Will the pump be used intermittently, or will it need to provide high-cycle operation? Does the application require that the pump be capable of starting under load?

Is fluid heat build-up a factor in your application? High cycle applications may require a larger capacity oil reservoir for cooling. Also, if you are using large displacement

cylinders, the reservoir capacity must be sufficient to fully extend the piston of the cylinder.

Will the application require large displacement or multiple cylinders? Reservoir size and pump output levels will be factors to consider.

Does the working environment require a pump having a low operating noise (dBA) level?

Must the pump operate in a spark-free environment?

MANUALLY-OPERATED HYDRAULIC PUMPS:

P12, P23, P55 – These single-speed pumps are for use with single-acting cylinders. See page 46.

P19, P59, P59F, P157, P159, P300, P460 – These 2-speed pumps are used with single-acting cylinders. The 2-speed feature provides high oil volume for fast cylinder piston approach to the work; pump automatically shifts to the high pressure stage. This reduces the number of pump handle strokes required. See pages 47-48.

P157D, P159D, P300D, P460D – These 2-speed pumps are used with double-acting cylinders. See page 48.

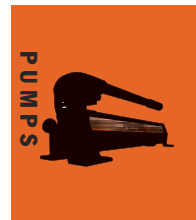

AIR/HYDRAULIC PUMPS

Used where air is the preferred energy source or where electricity is not available. Ideal for use in petrochemical, mines or other inflammable or explosive environments.

PA6 Series – These single-speed pumps drive single- or double-acting cylinders. See pages 50- 51.

PA9 Series – These new single-speed pumps drive single-acting cylinders and are ideal for powering portable hydraulic tools. See pages 54-55.

PA50 Series – These single-speed pumps drive single- or double-acting low pressure (3,200 psi) cylinders. See pages 58, 59.

PA60 – This 2-speed pump is equipped with a manifold to operate multiple cylinders, and provides a 2-gallon reservoir capacity. See pages 56-57.

PA64 – Similar to PA60, this 2-speed pump drives single- or double-acting cylinders. See pages 56-57.

PA172 and PA174 – These “economy” 2-speed pumps drive single- or double-acting cylinders, depending on the model chosen. Provide a low weight to output ratio. See pages 60-61.

PA462 and PA464 Series – These 2-speed pumps drive single or double-acting cylinders, depending on the model selected. They offer high speed cylinder piston advance. See pages 62-63.

PA554 – This 2-speed pump drives single- or double-acting cylinders, delivering a high volume of oil. See pages 60-62.

ELECTRIC/HYDRAULIC PUMPS

All of the following pumps are 2-speed models, and can be used to drive single- or double-acting cylinders.

“Quarter Horse” Series – As their name implies, these pumps feature a $\frac{1}{4}$ hp electric motor. A battery-powered version is available. Having a low noise level and weighing just 20 lbs., they are ideal for powering portable hydraulic spreaders, nut splitters, pipe flange spreaders and other tools. See pages 68-69.

PE17 Series – CSA rated for intermittent duty, these feature a $\frac{1}{2}$ hp, single phase induction motor with a low noise level (67-81 dBA). Smaller generators and low amperage circuits can be used as a power source. See pages 70-71.

PE46 Series – Powered by a $1\frac{1}{2}$ hp, single phase induction motor, operate at a moderate noise level of 77-81 dBA. CSA rated for intermittent duty. See pages 80-81.

PE18 Series – CSA rated for intermittent duty, these feature a $\frac{1}{2}$ hp, single phase universal motor with a noise level of 85-90 dBA. Provide high performance at a low price. Has low amperage draw. See pages 72-73.

PE30 Series – Equipped with a 1 hp, single phase permanent magnet motor, have a noise level of only 82-87 dBA. CSA rated for intermittent duty, and require a relatively low voltage; ideal for use in general construction applications. Roll cage/handle protects the motor and controls. See pages 78-79.

PE55 and PED25 Series – The famous Vanguard® pumps have been continually upgraded for 40 years; some of the originals are still in service! Equipped with a $1\frac{1}{8}$ hp, single phase universal motor, have a high noise level (90-95 dBA). Offer the best weight to performance ratio of any Power Team electric/hydraulic pump. CSA rated for intermittent duty. The PED25 versions are “dual flow” pumps which deliver the same low and high pressures to both valves, and have a noise level of 80-85 dBA. They have a $1\frac{1}{2}$ hp induction motor. See pages 76-77, 82-83.

PUMP SELECTION

Choose the
Right Pump



PE60 Series – The Vanguard® Supreme® pumps provide trouble-free service in the most severe working environments. Powered by a 1¹/₈ hp, single phase motor, has a moderate noise level of 80-85 dBA. Start well under load even at the reduced voltages encountered on construction sites. High-output pumps, ideal for use with post-tensioning/pre-stressing jacks and other high-pressure hydraulic tools. See pages 84-85.

“Custom-built” pumps – Power Team offers you “assemble to order” electric/hydraulic pumps to suit unique applications. You can choose from pre-engineered, off the-shelf components to customize your pump. See pages 100-103.

PE21 Series – Ideal for heavy-duty, extended-cycle applications. Powered by a 1 hp, single phase motor, pump operates a very low noise level of 70 dBA. Pump automatically shuts down in the event of a power failure. CSA rated for intermittent duty. See pages 86-87. “Quiet” Pumps. Our PQ60 and PQ120 series operate at a very low noise level of between 73-78 dBA. The PQ60 has a 2 hp (single phase) motor; the PQ120 has a 3 hp (3-phase) motor. These pumps are designed for heavy-duty, extended cycle operations. CSA rated for intermittent duty. See page 74.

PE400 Series – High-flow units deliver a large volume of high pressure oil for heavy construction and maintenance operations employing high tonnage cylinders. The PE400 is powered by a 10 hp, 3-phase motor. Low noise rating of 73-80 dBA. See pages 90-91.



GASOLINE-DRIVEN HYDRAULIC PUMPS

These two-speed pumps are ideal for use in remote applications, such as construction sites. May be used with single- or double-acting cylinders.

PG30 Series – Powered by a 2-cycle, 2 hp Tecumseh engine, these have an integral, protective “roll cage” and adequate reservoir capacity for cylinders up to 100 tons capacity or more. Readily portable; popular in the railroad, rescue and construction markets. See pages 94-95.

PG55 Series – With a 4-cycle, 4 hp Briggs & Stratton engine, this pump is based on our popular Vanguard® Series. It has a generous five gallon reservoir capacity. See pages 94-95.

PG120 Series – Powered by a 4-cycle, 5.5 hp Honda engine. Has a five gallon reservoir; capable of handling multiple-cylinder lifting tasks. Ideal for the structure moving, pier setting, bridge lifting and concrete contracting industries. See pages 96-97.

PG4004 – Featuring a 4-cycle, 18 hp Briggs & Stratton engine, this unit has a big 20 gallon reservoir. Rugged steel “roll cage” has a hook on top and swivel casters for ease of mobility. Popular for concrete stressing applications. See pages 96-97.



HYDRAULIC INTENSIFIER

HB Series – Turns low pressure hydraulic pumps into high pressure power sources to operate single-acting or double-acting cylinders and tools such as crimpers, spreaders, cutters, etc. Compact and portable for use inside a utility vehicle aerial bucket or stowing in a vehicle. See page 98.

**HYDRAULIC
PUMP
OPTIONS**

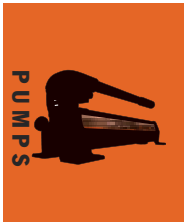
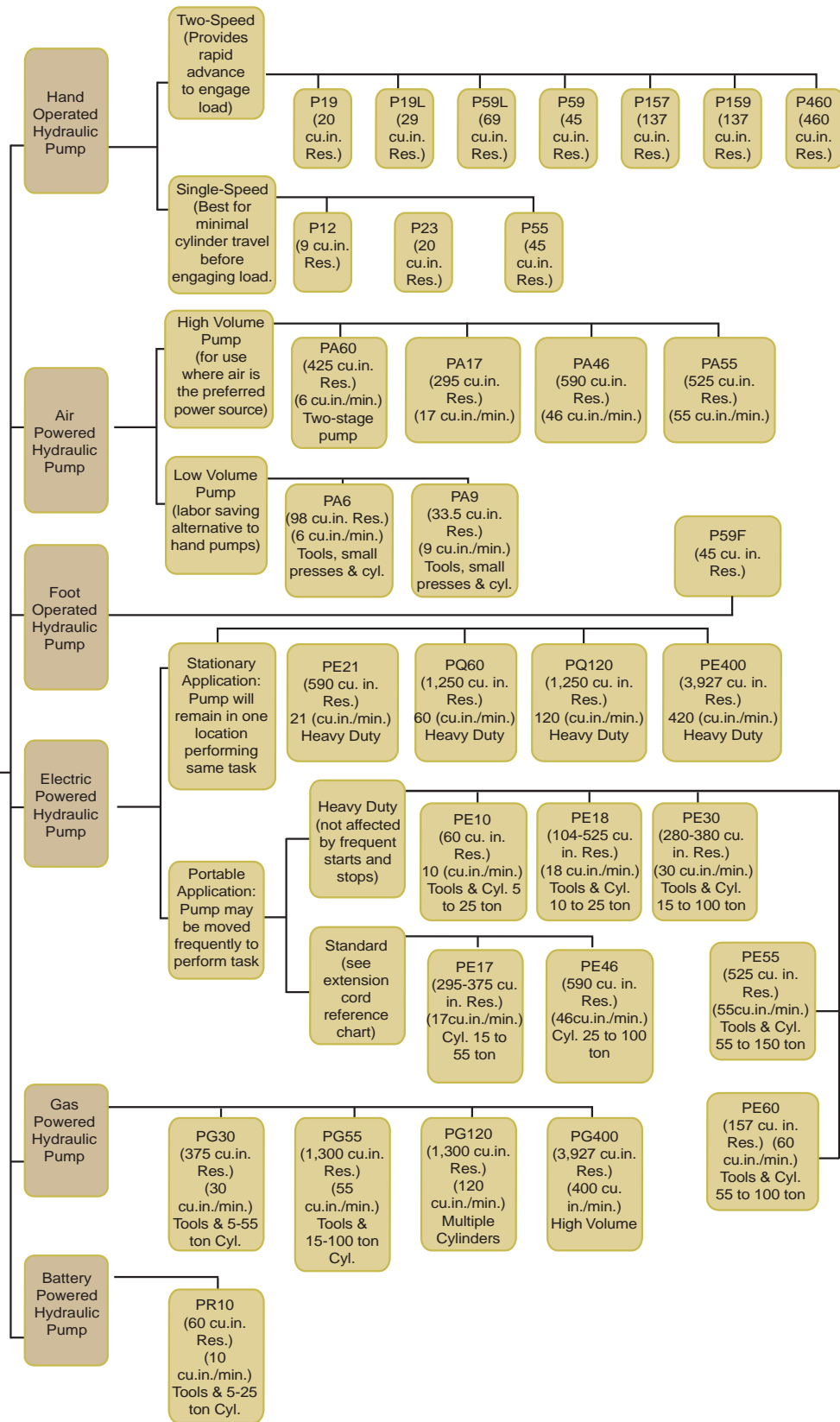

HAND PUMP

Hydraulic P Series

12 to 55 cu. in.

Single-Speed Single-Acting

BEST SUITED FOR APPLICATIONS WHERE THERE IS LITTLE OR NO FREE TRAVEL.

- All metal construction, won't burn through in welding environments.
- Formed metal handle provides less flex, and reduces operator fatigue.
- Convenient fill port on P23 and P55 allows pumps to be filled in a horizontal or vertical position.
- Fill cap seal acts as safety valve preventing over-pressurizing of reservoir.
- Relief valve inboard of check valve prevents loads from drifting down.
- Large valve knob gives added control for slowly metering loads down.



P23

10,000 psi



P12



P55

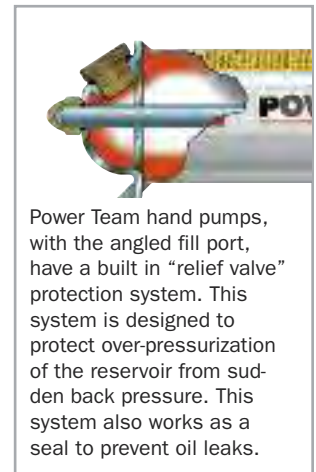
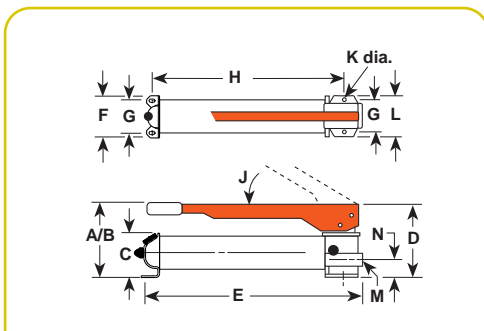

Power Team hand pumps, with the angled fill port, have a built in "relief valve" protection system. This system is designed to protect over-pressurization of the reservoir from sudden back pressure. This system also works as a seal to prevent oil leaks.

Pump No.	A (in.)	B (in.)	C (in.)	D (in.)	E (in.)	F (in.)	G (in.)	H (in.)	J (deg.)	K (in.)	L (in.)	M (in.)	N (in.)	P (in.)
P12	4	—	—	4	13 ¹ / ₂	3 ³ / ₈	2 ³ / ₁₆	—	45	3 ¹ / ₁₆	3 ³ / ₈	3 ¹ / ₈ NPTF	1 ¹ / ₈	—
* P23	6 ¹ / ₄	13	3 ¹ / ₂	5 ⁹ / ₁₆	13 ⁵ / ₈	4 ¹ / ₄	3 ¹ / ₄	10 ⁵ / ₁₆	38	5 ¹ / ₁₆	4 ³ / ₄	3 ¹ / ₈ NPTF	1 ⁵ / ₈	—
*The P23 pump maximum pressure is 3000 psi only.														
P55	6 ¹ / ₂	21	3 ¹ / ₂	5 ⁹ / ₁₆	23	4 ¹ / ₄	3 ¹ / ₄	19 ³ / ₄	38	5 ¹ / ₁₆	4 ³ / ₄	3 ¹ / ₈ NPTF	1 ⁵ / ₈	—

For Use With	Order No.	Volume & Pressure					Handle Effort (lbs.)	Reservoir		Oil Port (in.)	Product Weight (lbs.)
		Speed	Volume per Stroke (cu. in.)		Maximum Pressure (psi)			Oil Capacity (cu.in.)	Usable Oil Capacity (cu. in.)		
Single Acting	P12	1	—	.069	—	10,000	75	12	9	3 ¹ / ₈ NPTF	5.7
	P23	1	—	.160	—	3,000	70	23.8	20.3	3 ¹ / ₈ NPTF	12
Cylinders*	P55	1	—	.160	—	10,000	145	55	45	3 ¹ / ₈ NPTF	15.8

LP = Low Pressure
HP = High Pressure

* Pump includes 2-Way Valve



P59L

HAND PUMP

Hydraulic P Series

24.4 to 55 cu. in.
Two-Speed Single-Acting

10,000 psi

PUMP AUTOMATICALLY SHIFTS INTO THE HIGH PRESSURE LIFT STAGE UPON CONTACT WITH THE LOAD.

- All metal construction won't burn through in welding environments.
- Two-speed reduces handle strokes so you work faster and easier.
- Formed metal handle provides less flex, and reduces operator fatigue.
- Convenient fill port allows pumps to be filled in a horizontal or vertical position.
- Relief valve inboard of check valve prevents loads from drifting down.
- Large valve knob gives added control for slowly metering loads down.

P19L/P59L

- More usable oil volume — use with larger or longer stroke cylinders.
- True unloading valve set for 850 PSI (59 Bar) provides more efficiency and lower handle force.
- Link design reduces handle effort by 40%.
- Durable aluminum reservoir, manifold, and end cap.
- Ergonomic non-slip handle grip provides more comfort.
- Spring loaded handle lock incorporated into handle.

P59F

- Replaces hand control with foot controll

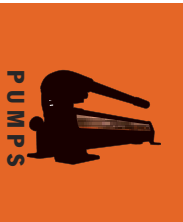

P19

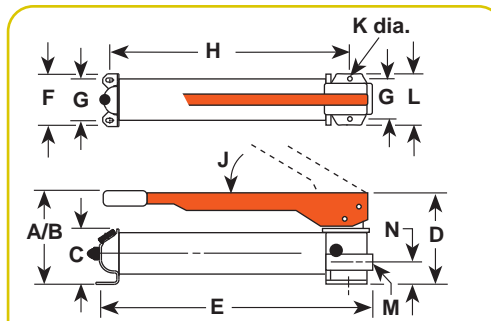

Foot pump conversion kit

No. FK59 - Foot pump conversion kit for use on P55/P59 pumps. Wt., 6 lbs.

No. FK159B - Foot pump conversion kit for use on P157/P159 and P300/P300D pumps. Wt., 6 lbs.

Pump No.	A (in.)	B (in.)	C (in.)	D (in.)	E (in.)	F (in.)	G (in.)	H (in.)	J (deg.)	K (in.)	L (in.)	M (in.)	N (in.)	P (in.)
P19	5 7/8	14 5/8	2 7/8	4 9/16	13 11/16	4	3 1/4	11 11/16	53°	5/16	4	3/8 NPTF	1 13/32	—
P19L	5 7/8	—	—	—	13 11/16	4 1/8	3 1/4	11	40°	5/16	—	3/8 NPTF	—	—
P59	7	21	3 1/2	5	23	4 3/4	3 3/4	19 3/4	38°	5/16	4 3/4	3/8 NPTF	1 5/8	—
P59L	7	—	—	—	21	5	3 3/4	19 3/4	50°	5/16	—	3/8 NPTF	—	—
P59F	3 1/2	16 3/4	3 1/2	6	23 3/4	4 1/4	3 3/4	20 1/4	—	5/16	4 1/2	3/8 NPTF	11 11/16	—

For Use With	Order No.	Volume & Pressure				Reservoir Handle Effort (lbs.)	Oil Capacity (cu.in.)	Usable Oil Capacity (cu. in.)	Oil Port (in.)	Product Weight (lbs.)	
		Speed	Volume per Stroke (cu. in.)		Maximum Pressure (psi)						
Single Acting	P19	2	.305	.076	325	10,000	99	24.4	20	3/8 NPTF	6.6
	P19L	2	.250	.050	850	10,000	78	29	27	3/8 NPTF	5.1
	P59	2	.662	.160	325	10,000	145	55	45	3/8 NPTF	17.2
Cylinders*	P59L	2	.720	.150	850	10,000	104	69	66	3/8 NPTF	8.9
	P59F	2	.550	.130	325	10,000	120	55	45	3/8 NPTF	14

LP = Low Pressure
HP = High Pressure

*Pump includes 2-Way Valve

HAND PUMP

Hydraulic P Series

152 cu. in.

Two-Speed Single-
and Double-Acting

BEST SUITED FOR APPLICATIONS WHERE THERE IS LITTLE OR NO FREE TRAVEL.

- Rugged all metal construction for strength and durability that won't burn through in welding environments.
- Heavy-duty, formed metal handle provides less flex, and less operator fatigue than round or composite handles.
- Convenient fill port on P23 and P55 allows pumps to be filled in a horizontal or vertical position.
- Fill cap seal acts as safety valve to prevent over-pressurizing of reservoir.
- Relief valve inboard of check valve prevents loads from drifting down.
- Large valve knob gives added control for slowly metering loads down.



P157/P159



P300



P460



P300 hand pump and 10 ton cylinders used for a vehicle lift.



P159D

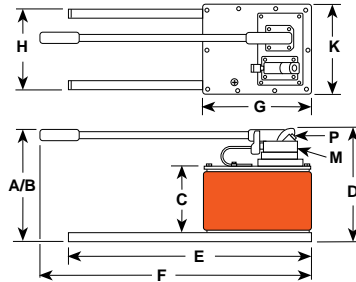
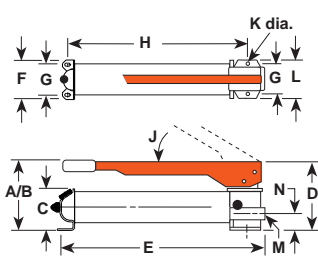

FK59
FK159B

Foot pump conversion kit

No. FK59 - Foot pump conversion kit for use on P55/P59 pumps. Wt., 6 lbs.

No. FK159B - Foot pump conversion kit for use on P157/P159 and P300/P300D pumps. Wt., 6 lbs.

Pump No.	A (in.)	B (in.)	C (in.)	D (in.)	E (in.)	F (in.)	G (in.)	H (in.)	J (deg.)	K (in.)	L (in.)	M (in.)	N (in.)	P (in.)
P157/P159	7 ³ / ₄	20 ¹ / ₂	4 ⁷ / ₈	6 ⁷ / ₈	22 ³ / ₄	3 ⁷ / ₈	3	19 ³ / ₄	39	5 ⁵ / ₁₆	3 ³ / ₄	3 ³ / ₈ NPTF	2 ¹ / ₄	—
P300	8 ¹ / ₄	21	4 ¹ / ₂	6 ⁷ / ₈	22 ⁵ / ₈	8 ¹ / ₂	7 ¹ / ₂	3	20 ²³ / ₃₂	39	5 ⁵ / ₁₆	3 ³ / ₄	3 ³ / ₈ NPTF	2 ¹ / ₄
P460	11 ¹ / ₈	31	6 ³ / ₄	11 ³ / ₈	24	29 ¹ / ₄	11	9	80	9 ¹ / ₂	—	3 ³ / ₈ NPTF	—	1 ¹ / ₄

For Use With	Order No.	Speed	Volume & Pressure		Maximum Pressure (psi)		Reservoir Handle Effort (lbs.)	Oil Capacity (cu.in.)	Usable Oil Capacity (cu. in.)	Oil Port (in.)	Product Weight (lbs.)
			Volume per Stroke (cu. in.)	LP	HP	LP					
Single-Acting	P157	2	.650	.160	1,400	10,000	140	152	137	3 ³ / ₈ NPTF	26.7
	P159	2	2.6	.160	325	10,000	140	152	137	3 ³ / ₈ NPTF	26.2
Cylinders*	P300	2	2.6	.160	325	10,000	140	1.5 gal.	310	3 ³ / ₈ NPTF	55.3
	P460	2	7.35	.294	325	10,000	90	2.5 gal.	460	3 ³ / ₈ NPTF	54.9
Double-Acting	P157D	2	.650	.160	1,400	10,000	140	152	137	3 ³ / ₈ NPTF	28.8
	P159D	2	2.6	.160	325	10,000	140	152	137	3 ³ / ₈ NPTF	27.9
Cylinders**	P300D	2	2.6	.160	325	10,000	140	1.5 gal.	310	3 ³ / ₈ NPTF	57.0
	P460D	2	7.35	.294	325	10,000	90	2.5 gal.	460	3 ³ / ₈ NPTF	57.9

LP = Low Pressure
HP = High Pressure

* Pump includes 2-Way Valve

** Pump includes 4-Way Valve

PRECISION-MATCHED CYLINDER AND PUMP SET FOR WIDE RANGE OF APPLICATIONS.

- Four styles of cylinders to choose from.
- Sets feature single- or two-speed hydraulic hand pumps.
- Cylinders of various tonnages with long, medium or short stroke.
- Includes necessary fittings, couplers and 6 foot hose.
- Gauge and gauge mounting adapter is recommended. (See pages 110-111)



CYLINDER/PUMP

RPS Series

Cylinder and pump Set

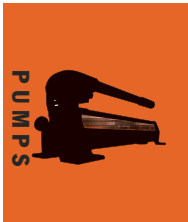

Optional Storage Box Storage box for hydraulic cylinder and pump sets. Rugged industrial strength material, strong as steel, never needs painting, won't rust, dent or chip. Weatherproof lid is self sealing and lockable. Molded-in handles, water-tight, one piece bottom and side construction. Strong enough to stand on. **Note:** Actual product may differ from photo. **No. 350722** – 35"L x 14"H x 13¹/₂"W, storage box.

Style of Cyl.	Cyl. Cap. (tons)	Stroke (in.)	Order No.	Retracted Height (in.)	Handle Strokes Required to Fully Extended Cylinder	Cyl. No.	Pump No.	Hose No.	Coupler No.	Pump Speed	Prod. Wt. (lbs.)
	5	5 ¹ / ₄	RPS55	8 ¹ / ₂	75	C55C	P12	9756	9798	Single	12
	10	2 ⁷ / ₈	RPS102**	4 ³ / ₄	32	C102C	P55	9756	9798	Single	26
	10	6 ⁷ / ₈	RPS106**	9 ³ / ₄	93	C106C	P55	9756	9798	Single	32.1
	10	10 ⁷ / ₈	RPS1010**	13 ³ / ₄	154	C1010C	P55	9756	9798	Single	35.6
"C" Series	15	4 ⁷ / ₈	RPS154**	7 ⁷ / ₈	81	C154C	P55	9756	9798	Single	29
	15	6 ⁷ / ₈	RPS156**	10 ¹¹ / ₁₆	118	C156C	P55	9756	9798	Single	34
	25	6 ¹ / ₄	RPS256**	10 ³ / ₄	219	C256C	P55	9756	9798	Single	42.7
	25	14 ¹ / ₄	RPS2514**	18 ³ / ₄	285*	C2514C	P159	9756	9798	Two	62.7
	55	6 ¹ / ₄	RPS556**	11 ⁷ / ₈	268*	C556C	P159	9756	9798	Two	82.7
	100	6 ⁵ / ₈	RPS1006	13 ³ / ₄	428*	C1006C	P460	9756	9798	Two	128.7
"Shorty"	30	2 ⁷ / ₁₆	RPS302**	4 ⁵ / ₈	61*	RSS302	P59	9756	9798	Two	40
	50	2 ³ / ₈	RPS552**	5	89*	RSS502	P59	9756	9798	Two	50
	100	2 ⁷ / ₄	RPS1002**	5 ¹ / ₂	172*	RSS1002	P59	9756	9798	Two	81
"Center-Hole"	20	3	RPS203H**	6 ¹ / ₁₆	80	RH203	P55	9756	9798	Single	40.5
Alum.	55	6 ⁷ / ₈	RPS556A**	10 ³ / ₄	262*	RA556	P159	9756	9798	Two	47

* Base on 50% if the stroke being made at low-pressure and 50% of the strokes at high pressure.

** Add suffix "B" (example: RPS102B, RPS203HB, etc.) to order set with optional storage box shown above.

AIR PUMP

Hydraulic PA6 Series

Single-Acting

COMPACT, LIGHTWEIGHT AND PORTABLE. SINGLE-SPEED PUMPS DESIGNED TO DRIVE SINGLE-ACTING CYLINDERS.

- The power unit of choice for major manufacturers of auto body, frame straighteners and other equipment.
- Operate at 40-100 psi shop air pressure.
- dBA 85 at 10,000 psi.

- Serviceable pump motor is not a “throw away”, providing economical repair.
- Permanently vented reservoir cap.
- Internal relief valve protects circuit components, air inlet filter protects motor.

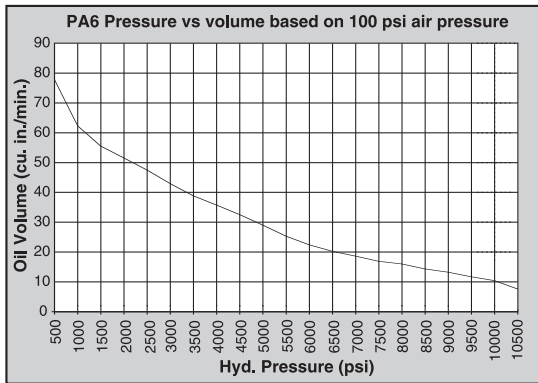

10,000 psi

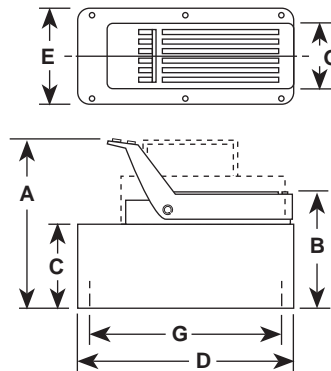

Pump No.	A (in.)	B (in.)	C (in.)	D (in.)	E (in.)	G (in.)
PA6	7 ³ / ₄	5 ⁷ / ₈	4 ³ / ₈	9 ¹ / ₂	5	4 x 9
PA6A	7 ³ / ₄	5 ⁷ / ₈	4 ³ / ₈	9 ¹ / ₂	5	4 x 9
PA6AM	7 ³ / ₄	5 ⁷ / ₈	4 ³ / ₈	9 ¹ / ₂	5	4 x 9
PA6M	7 ³ / ₄	5 ⁷ / ₈	4 ³ / ₈	9 ¹ / ₂	5	4 x 9
PA6R	7 ³ / ₄	5 ⁷ / ₈	4 ³ / ₈	9 ¹ / ₂	5	4 x 9
PA6RM	7 ³ / ₄	5 ⁷ / ₈	4 ³ / ₈	9 ¹ / ₂	5	4 x 9
PA6M-1	7 ⁷ / ₈	6	4 ³ / ₈	12 ⁵ / ₈	7 ³ / ₈	—
PA6-2	10 ¹ / ₄	8	7	11 ¹ / ₂	9 ¹ / ₂	5 ¹ / ₈ x 7 ¹ / ₈



PA6M-1



PA6-2

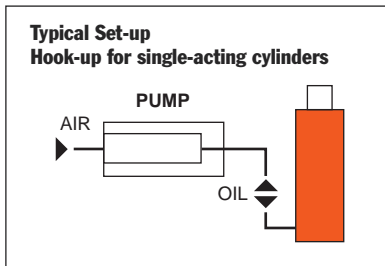
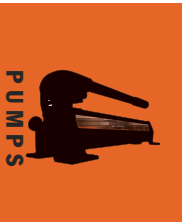

Description	Order No.	Air Supply Req'd (psi)	Reservoir		Oil Port (in)	Prod. Wt. (lbs.)
			Cap. (cu. in.)	Usable (cu. in.)		
Base model pump with high density polyethylene reservoir.	PA6	40-120	105	98	3/8 NPTF	14
PA6 with externally adjustable relief valve.	PA6A	40-120	105	98	3/8 NPTF	15
PA6A with metal reservoir.	PA6AM	40-120	105	98	3/8 NPTF	17
PA6, except has metal reservoir.	PA6M	40-120	105	98	3/8 NPTF	18
PA6 with 12 foot remote control.	PA6R	40-120	105	98	3/8 NPTF	20.58
PA6R, except has metal reservoir.	PA6RM	40-120	105	98	3/8 NPTF	21.58
PA6, except has 1 gallon metal reservoir.	PA6M-1	40-120	1 gal.	185	3/8 NPTF	23.7
PA6, except has 2 gallon, high density polyethylene reservoir.	PA6-2	40-120	2 gal.	454	3/8 NPTF	24.5
PA6, except has 2 1/2 gallon metal reservoir.	PA6M-2	40-120	2 1/2 gal.	570	3/8 NPTF	32.1

AIR PUMP

Hydraulic PA6D Series

6 cu. in./min.
Double-Acting

- Operate at 40-100 psi shop air pressure at the pump.
- Internal relief valve protects circuit components, air inlet filter protects motor.
- Serviceable pump motor is not a “throw away”, providing economical repair.
- Permanently vented reservoir cap.
- dBA 85 at 10,000 psi for all PA6 pumps.

COMPACT, LIGHTWEIGHT AND PORTABLE SINGLE-SPEED PUMP FOR DRIVING DOUBLE-ACTING CYLINDERS.

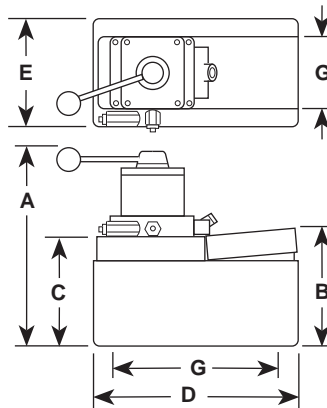
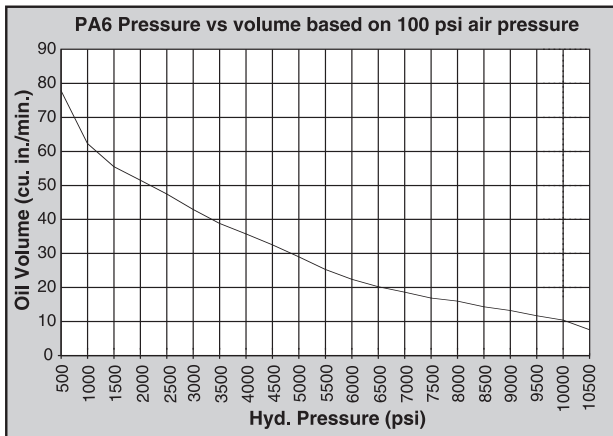

Pump No.	A (in.)	B (in.)	C (in.)	D (in.)	E (in.)	G (in.)
PA6D	10 ³ / ₈	5 ⁷ / ₈	4 ³ / ₈	9 ¹ / ₂	5	4 x 9
PA6DM	10 ³ / ₈	5 ⁷ / ₈	4 ³ / ₈	9 ¹ / ₂	5	4 x 9
PA6DM-1	11	5 ³ / ₄	4 ³ / ₈	12 ³ / ₈	7 ³ / ₈	—
PA6D2	12 ³ / ₄	8	7	11 ⁵ / ₁₆	9 ¹ / ₄	5 ¹ / ₈ x 7 ¹ / ₈
PA6DM-2	12 ¹ / ₂	7 ³ / ₄	6 ³ / ₄	11 ¹ / ₂	9 ¹ / ₂	8 x 10



PA6DM-1



PA6D2

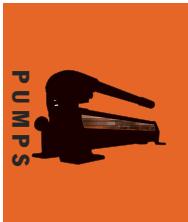

PA6D pump, DG100 digital pressure gauge and 25 ton cylinder used in a test fixture.

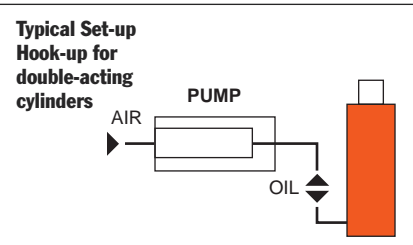

Description	Order No.	Valve No.	Air Supply Req'd (psi)	Reservoir		Oil Port (in.)	Prod. Wt (lbs.)
				Cap. (cu. in.)	Usable (cu. in.)		
Base model pump with high density polyethylene reservoir.	PA6D	9504, 3-way/4-way	40-120	105	98	3/8 NPTF	18.4
PA6D, except has metal reservoir.	PA6DM	9504, 3-way/4-way	40-120	105	98	3/8 NPTF	20.4
PA6D, except has 1 gallon metal reservoir.	PA6DM-1	9504, 3-way/4-way	40-120	1 gal.	185	3/8 NPTF	28.1
PA6D, except has 2 gallon, high density polyethylene reservoir.	PA6D2	9504, 3-way/4-way	40-120	2 gal.	454	3/8 NPTF	28.6
PA6D, except has 2 1/2 gallon metal reservoir.	PA6DM-2	9504, 3-way/4-way	40-120	2 1/2 gal.	570	3/8 NPTF	36.2

AIR PUMP

Hydraulic PA9 Series

9 cu. in./min.
Single-Acting

**IDEAL FOR POWERING
SINGLE-ACTING CYLINDERS
AND PORTABLE
HYDRAULIC TOOLS.**

- Easier to operate than a hand pump, giving you the speed you need at an affordable price.
- Easy and economical to service; not a “throw away” unit.
- Unique bladder design for all-position operation and storage.
- Operates on 40-120 psi shop air, at 20 cfm.
- Hard-coat anodized aluminum housing.
- Oil filler with integral safety relief minimizes chance of damage to reservoir bladder if overfilling occurs.

PA9 Foot Control

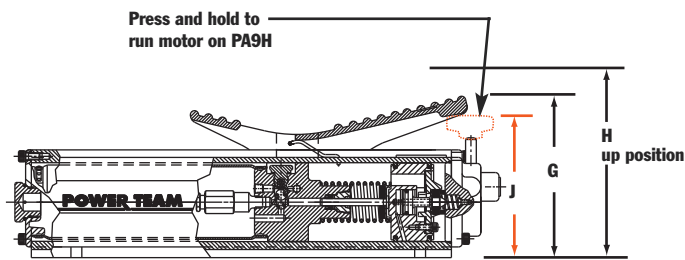
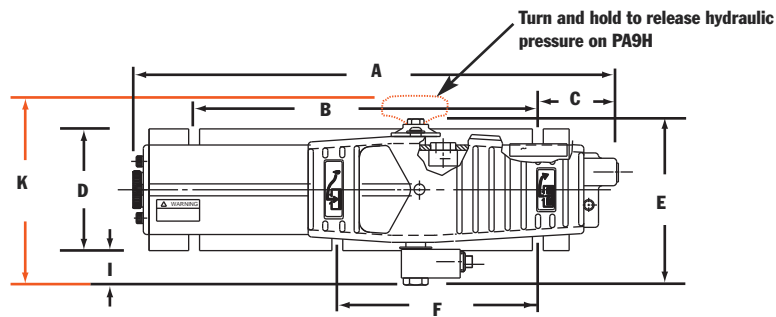

Relief valve settings: up to 10,000 psi
Mounting holes (standard): $\frac{3}{8}$ " slots

Pump No.	A (in.)	B (in.)	C (in.)	D (in.)	E (in.)	F (in.)	G (in.)	H (in.)	I (in.)	J (in.)	K (in.)
PA9	$16\frac{15}{16}$	12	$2\frac{13}{16}$	$4\frac{1}{4}$	$5\frac{5}{16}$	7	$5\frac{5}{8}$	7	$1\frac{1}{8}$	—	—
PA9H	$16\frac{15}{16}$	12	$2\frac{13}{16}$	$4\frac{1}{4}$	—	7	—	7	$1\frac{1}{8}$	$4\frac{13}{16}$	$6\frac{11}{16}$



PA9
Foot Control

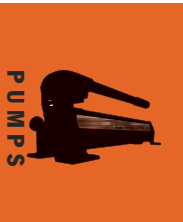

PA9H Hand Control Pump as used in a straightening press.



PA9H
Hand Control

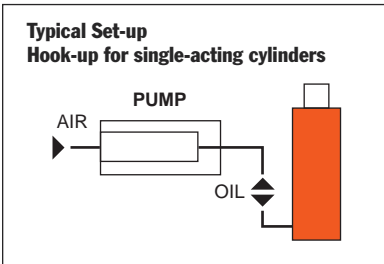
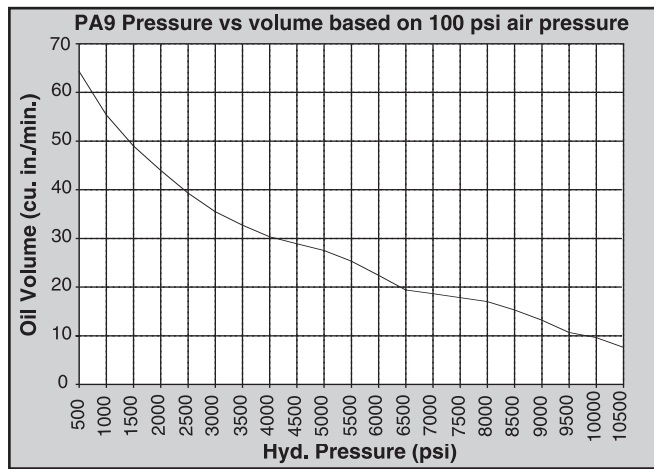

For Use with Cyl. Type	Order No.	Air Supply Req'd (psi)	Reservoir		Oil Port (in.)	Max. Pressure Output (psi)	Prod. Wt. (lbs.)
			Cap. (cu. in.)	Usable (cu. in.)			
Single-Acting	PA9	40-120	35	33.5	3/8 NPTF	10,000	15
Single-Acting	PA9H	40-120	35	33.5	3/8 NPTF	10,000	15

AIR PUMP

Hydraulic PA60 Series

6 cu. in./min.

Two-Speed

TWO-SPEED PUMP FOR RAPID OIL DELIVERY AT LOW PRESSURE QUICKLY ADVANCES CYLINDER OR TOOL.

- Equipped with air pressure regulator, air filter and lubricator.
- Serviceable air motor for economical repair.
- Internal relief valve protects circuit components.
- Permanently vented reservoir cap.

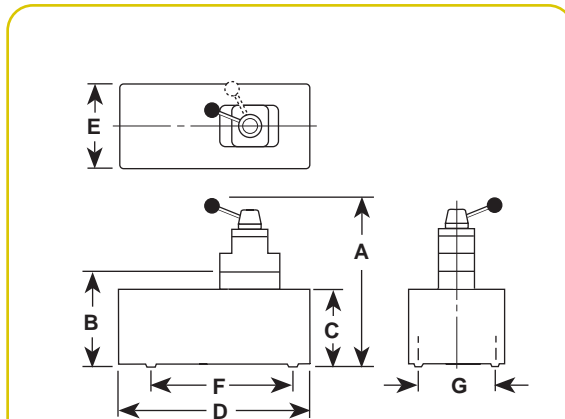

The PA60 used in a workholding environment.

Pump No.	A (in.)	B (in.)	C (in.)	D (in.)	E (in.)	F (in.)	G (in.)	Max. Pressure Output (psi)	Oil Del. * (cu. in./min. @)				
									0 (psi)	100 (psi)	1,000 (psi)	5,000 (psi)	10,000 (psi)
PA60	—	9 ⁷ / ₁₆	8 ⁷ / ₈	14 ¹ / ₄	9 ⁵ / ₈	7 ¹ / ₈	5 ¹ / ₈	10,000	390	350	50	12	6
PA64	14 ¹ / ₄	—	8 ⁷ / ₈	14 ¹ / ₄	9 ⁵ / ₈	7 ¹ / ₈	5 ¹ / ₈	10,000	390	350	50	12	6

* Typical delivery. Actual flow will vary with field conditions.

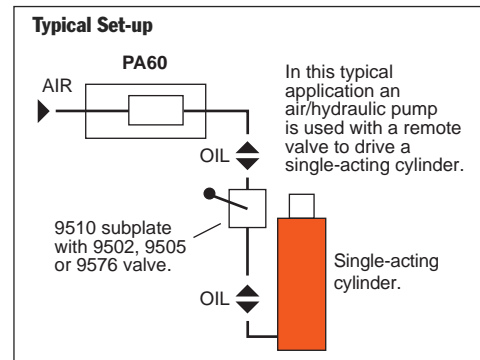
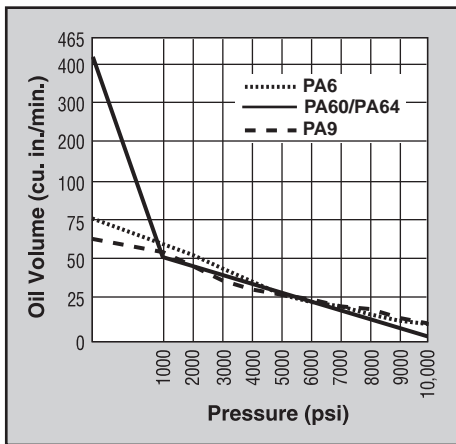
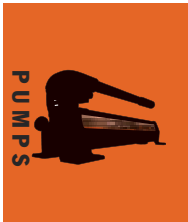
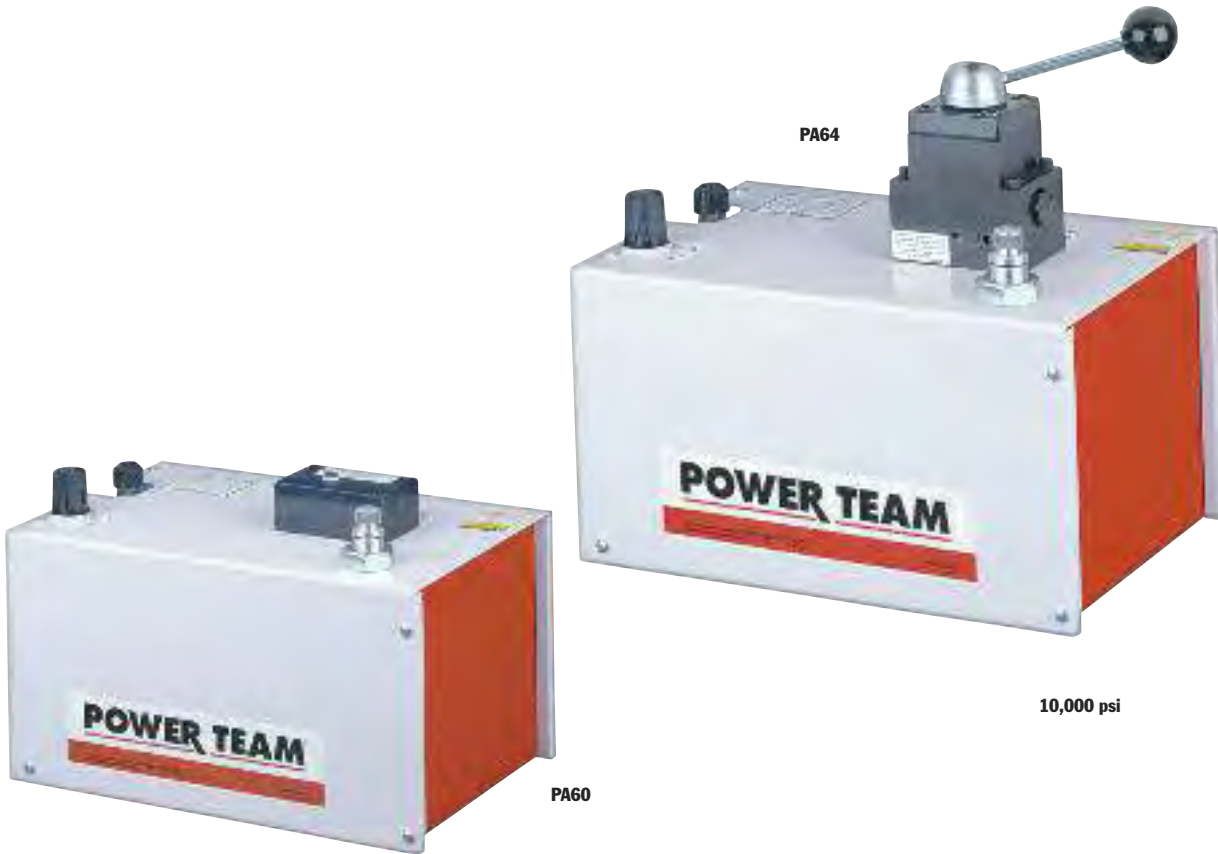

Description	Order No.	Valve No.	Valve Function	Air Supply	Reservoir		Oil Port (in.)	Prod. Wt (lbs.)
				Req'd (psi)	Cap. (gal.)	Usable (cu. in.)		
For use with remote valves.	PA60	Manifold	—	40-120	2	425	3/8 NPTF	54
For use with single- or double-acting cylinders.	PA64	9507, 3-way/ 4-way	Advance Hold Return	40-120	2	425	3/8 NPTF	56

Notes: Air inlet port 1/4" NPTF. Requires 20 cfm at 100 psi shop air pressure at the pump.

AIR PUMP

Hydraulic PA50 Series

28 cu. in./min.

Low Pressure

**SINGLE-SPEED, LOW PRESSURE
(3,200 PSI) OUTPUT PUMPS.**

PA50D



PA50M

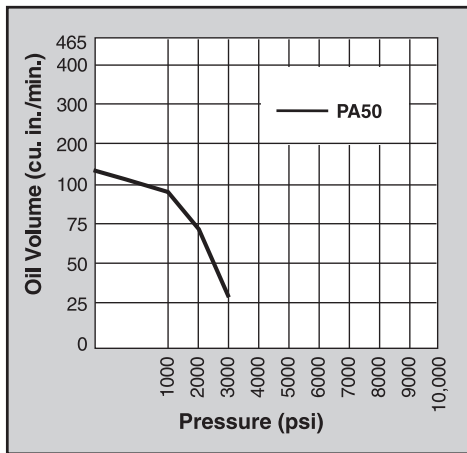
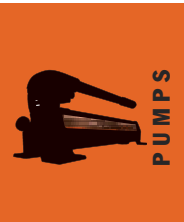

PA50, PA50M, PA50R, PA50RM,
PA50R2

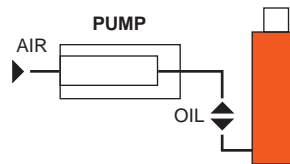
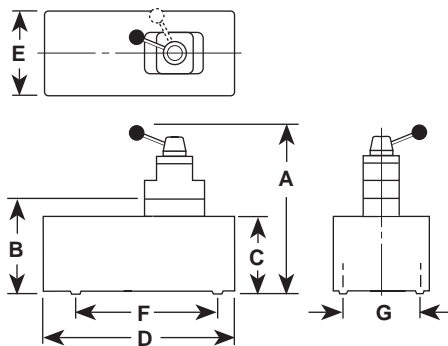

Pump No.	A (in.)	B (in.)	C (in.)	D (in.)	E (in.)	F (in.)	G (in.)	Max. Pressure Output (in.)	Oil Del. * (cu. in./min. @)					
									0 (psi)	100 (psi)	1,000 (psi)	5,000 (psi)	10,000 (psi)	
PA50, PS50R														
PA50M, PA50RM	7 ³ / ₄	5 ⁷ / ₈	4 ³ / ₈	9 ¹ / ₂	5	—	4 X 9	3,200	128	110	88	28 †	—	
PA50R2	10 ¹ / ₄	8	7	11 ¹ / ₂	9 ¹ / ₂	—	5 ¹ / ₈ X 7 ¹ / ₈	3,200	128	110	88	28 †	—	
PA50D	10 ³ / ₈	5 ⁷ / ₈	4 ³ / ₈	9 ¹ / ₂	5	9	4	3,200	128	110	88	28 †	—	

* Typical delivery. Actual flow will vary with field conditions.

† PA50 Series measured at 3,200 psi.

- Serviceable air motor for economical repair.
- Air inlet filter protects motor. Filter in outlet port protects against contaminated systems.
- Assorted reservoirs to suit your application's requirements.

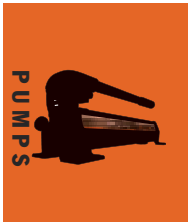
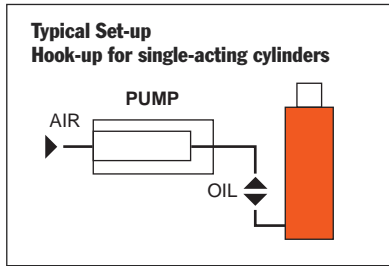

For use with Cyl. Type	Description	Order No.	Valve No.	Air Supply Req'd (psi)	Reservoir		Oil Port (in.)	Prod. Wt (lbs.)
					Cap. (cu. in.)	Usable (cu. in.)		
Single-Acting	Base model pump with high density polyethylene reservoir.	PA50	—	40-120	105	98	3/8 NPTF	14.2
Single-Acting	PA50, except has metal reservoir.	PA50M	—	40-120	105	98	3/8 NPTF	16.2
Single-Acting	PA50, except has 12 foot remote control.	PA50R	—	40-120	105	98	3/8 NPTF	18.5
Single-Acting	PA50, except has metal reservoir.	PA50RM	—	40-120	105	98	3/8 NPTF	20.5
Single-Acting	PA50R, except has 2 gallon reservoir.	PA50R2	—	40-120	2 gal.	454	3/8 NPTF	28.5
Single- and Double Acting	PA50, except designed to operate either single- or double-acting systems. Valve function: Advance / Return.	PA50D	9504, 3-way/ 4-way	40-120	105	98	3/8 NPTF	18.4

Notes: Air inlet port 1/4" NPTF. Requires 20 cfm at 100 psi shop air pressure at the pump.

AIR PUMP

Hydraulic PA17 Series

17 cu. in./min.

Two Speed



The PA17 used with a flange spreader

ROTARY-STYLE AIR MOTOR. USE WHERE AIR IS PREFERRED SOURCE OF ENERGY, WHERE ELECTRICITY IS UNAVAILABLE OR SPARKS ARE A CONCERN.

- Two-speed operation for high speed cylinder advance.
- Durable two gallon thermoplastic reservoir. (Metal reservoir conversion kits are available.)
- Features air motor capable of starting under full load.

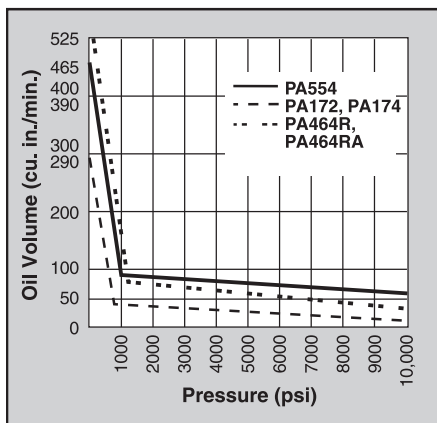

PA172

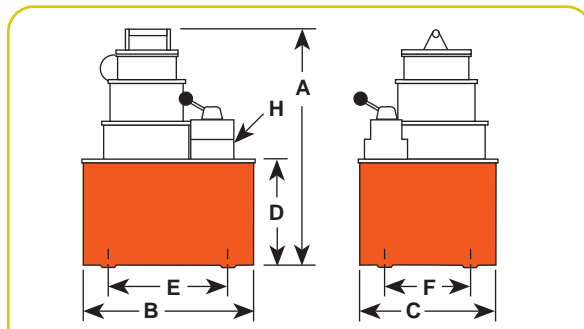

Pump No.	A (in.)	B (in.)	C (in.)	D (in.)	E (in.)	F (in.)	H (in.)	Max. Pressure Output (psi)	Oil Del. * (cu. in./min. @)				
									0 (psi)	100 (psi)	1,000 (psi)	5,000 (psi)	10,000 (psi)
PA172	14 ¹ / ₈	11 ³ / ₈	9 ¹ / ₄	7	7 ¹ / ₈	5 ¹ / ₈	3/8 NPTF	10,000	290	240	24	23	17
PA174	14 ¹ / ₈	11 ³ / ₈	9 ¹ / ₄	7	7 ¹ / ₈	5 ¹ / ₈	3/8 NPTF	10,000	290	240	24	23	17

* Typical delivery. Actual flow will vary with field conditions.

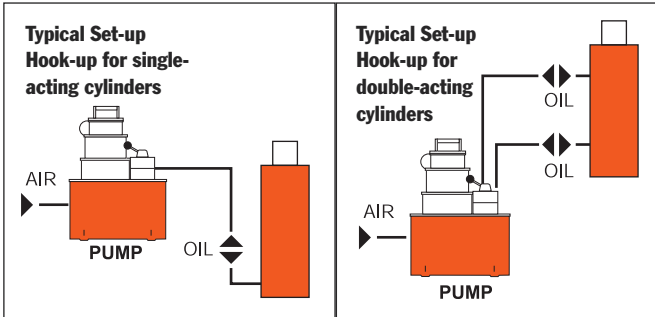

For use with Cyl. Type	Description	Order No.	Valve No.	Valve Function	Air Supply Req'd (psi)	Reservoir Cap. (gal.)	Usable (cu. in.)	Prod. Wt (lbs.)
Single-Acting	Base model pump with 2 gallon thermoplastic reservoir.	PA172	9517, 2-way	Advance/Return*	40-120	2	295	40
Single- and Double Acting	PA172, except has 9500 valve for use with single- or double-acting cylinders.	PA174	9500, 4-way	Advance Hold Return*	40-120	2	295	41

Note: Requires 20 cfm at 80 psi shop air pressure at the pump. dBA 85/90 at 10,000 psi.

* Holds pressure in advance position when valve motor is shut off, in return position with motor running. Pump will build pressure when motor is shut off, oil returns to reservoir.

AIR PUMP

PA46/55 Series

Up to 150 ton
46-55 cu. in./min.
Two Speed

ROTARY-STYLE AIR MOTOR. USE WHERE AIR IS THE PRE- FERRED SOURCE OF ENERGY.

- 3 hp motor starting under full load.
- Two-speed operation for rapid cylinder advance.
- Models available with full remote control over advance and return, (except PA554).
- Tandem center valve holds the load when pump is shut off.



PA462

10,000 psi

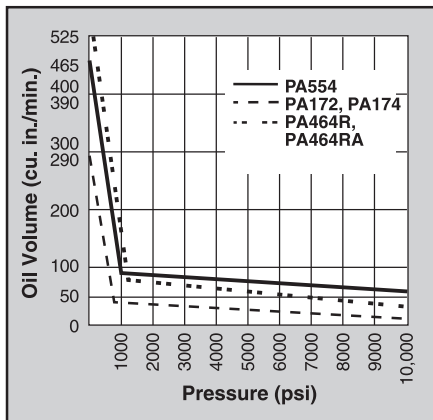

PA554 pump and RH2008 Center Hole cylinder used to tension cables.

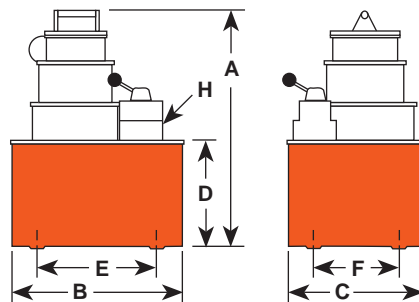

Pump No.	A (in.)	B (in.)	C (in.)	D (in.)	E (in.)	F (in.)	H (in.)	Max. Pressure Output (psi)	Oil Del. * (cu. in./min. @)				
									0 (psi)	100 (psi)	1,000 (psi)	5,000 (psi)	10,000 (psi)
PA462	15	11 ¹ / ₂	9 ¹ / ₂	7	10	8	3/8 NPTF	10,000	465	450	53	51	46
PA464	15	11 ¹ / ₂	9 ¹ / ₂	7	10	8	3/8 NPTF	10,000	465	450	53	51	46
PA464R	15	11 ¹ / ₂	9 ¹ / ₂	7	10	8	3/8 NPTF	10,000	465	450	53	51	46
PA464RA	15	11 ¹ / ₂	9 ¹ / ₂	7	10	8	3/8 NPTF	10,000	465	450	53	51	46
PA554	19	11 ¹ / ₂	9 ¹ / ₂	7	10	8	3/8 NPTF	10,000	465	450	80	70	55

* Typical delivery. Actual flow will vary with field conditions.

Note: Four mounting holes 1/2" - 20



PA464R



PA554

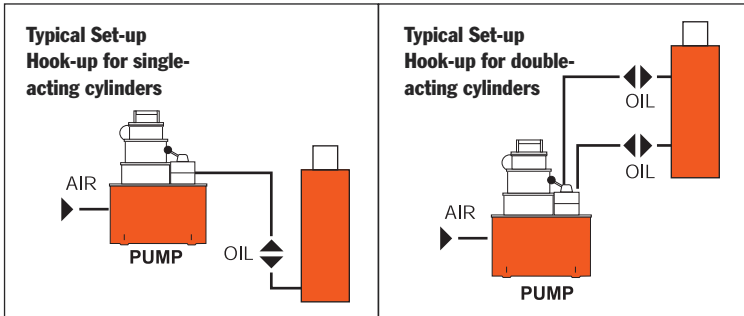
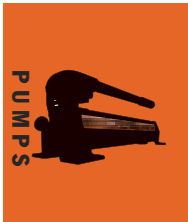

For use with Cyl. Type	Description	Order No.	Valve No.	Valve Function	Air Supply	Reservoir		Prod. Wt (lbs.)
					Req'd (psi)	Cap. (gal.)	Usable (cu. in.)	
Single-Acting	Base model pump with 2½ gallon steel reservoir.	PA462	9584,	Advance/ Hold/Return	40-120	2½	590	60
Single- and Double Acting	PA462, except has 9500 valve capable of running 2 single-acting cylinders or one double-acting cylinder.	PA464	9500,	Advance/ Hold/Return*	40-120	2½	590	61
Single- and Double Acting	PA462 with air actuated valve for full remote control over advance and return. Includes 12 ft. remote control.	PA464R†	9594,	Advance/ Hold/Return	40-120	2½	590	78
Single- and Double Acting	PA464R except, has automatic dump feature. 25 ft. remote control.	PA464RA**†	9594,	Advance/ Hold/Return*	40-120	2½	590	79
Single- and Double Acting	High performance pump with 2½ gallon steel reservoir.	PA554	9500,	Advance/ Hold/Return*	40-120	2½	525	72

Note: Requires 50 cfm at 80 psi shop air pressure at the pump. dBA 85/90 at 10,000 psi.

* Holds when motor is shut-off and valve is in “advance” position.

† The PA464RA has an “automatic dump” feature. Pressure is not held when operator releases “advance” or “return” button. PA464R will “hold” only in the “advance” position with the motor shut off.

** Not to be used for lifting.

AIR OPERATED

PUA & PMA Series

35,000 psi

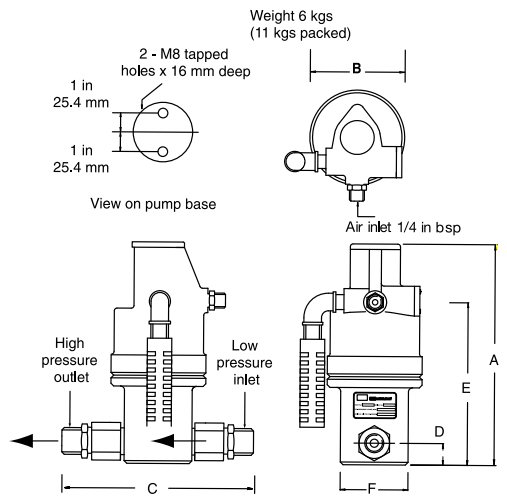
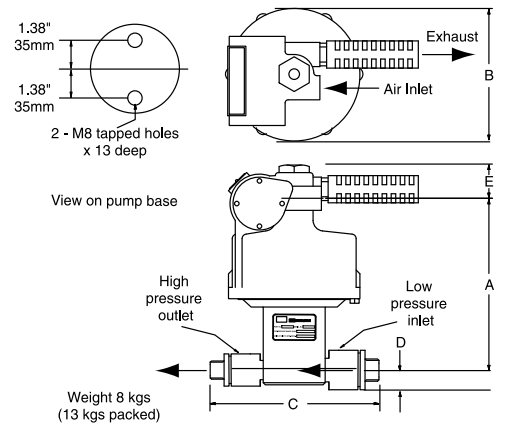

CAT #	RAM/DIAMETER		in	A	B	C	D	E	F
	(mm)	(in)							
PUA26(B/U)	31.75	1 1/4	in	9.17	4.02	6.61	.87	6.69	2.87
			mm	233	102	168	22.2	170	73
PUA70(B/U)	19	3/4	in	8.74	4.02	6.61	.87	6.22	2.87
			mm	222	102	168	22.2	158	73
PUA157(B/U)	12.7	1/2	in	8.74	4.02	6.61	.87	6.22	2.87
			mm	222	102	168	22.2	158	73
PUA275(B/U)	9.53	3/8	in	8.74	4.02	6.61	.87	6.22	2.87
			mm	222	102	168	22.2	158	73
PUA430(B/U)	7.94	5/16	in	8.74	4.02	6.61	.87	6.22	2.87
			mm	222	102	168	22.2	158	73
PUA655(B/U)	6.35	1/4	in	8.74	4.02	6.61	.87	6.22	2.87
			mm	222	102	168	22.2	158	73
PUA982(B/U)	5.13	.202	in	8.74	4.02	6.61	.87	6.22	2.87
			mm	222	102	168	22.2	158	73
PMA27(B/U)	76.2	3	in	8.66	7.01	9.06	1.5	1.89	
			mm	220	178	230	38	48	
PMA60(B/U)	50.8	2	in	8.27	7.01	9.06	1.5	1.89	
			mm	210	178	230	38	48	
PMA90(B/U)	41.3	1 5/8	in	8.27	7.01	9.06	1.5	1.89	
			mm	210	178	230	38	48	

CAT #	RAM/DIAMETER		in	A	B	C	D	E	F
	(mm)	(in)							
PMA130(B/U)	35	1 3/8	in	7.99	7.01	7.68	.87	1.89	
			mm	203	178	195	22	48	
PMA190(B/U)	28.5	1 1/8	in	7.99	7.01	7.68	.87	1.89	
			mm	203	178	195	22	48	
PMA240(B/U)	25.4	1	in	7.99	7.01	7.68	.87	1.89	
			mm	203	178	195	22	48	
PMA370(B/U)	20.6	13/16	in	7.99	7.01	7.01	.87	1.89	
			mm	203	178	178	22	48	
PMA520(B/U)	17.5	11/16	in	7.99	7.01	7.01	.87	1.89	
			mm	203	178	178	22	48	
PMA770(B/U)	14.3	9/16	in	7.99	7.01	7.01	.87	1.89	
			mm	203	178	178	22	48	
PMA980(B/U)	12.7	1/2	in	7.99	7.01	7.01	.87	1.89	
			mm	203	178	178	22	48	
PMA1740(B/U)	9.5	3/8	in	7.99	7.01	10.08	.87	1.89	
			mm	203	178	256	22	48	
PMA2410(B/U)	8	5/16	in	7.99	7.01	10.08	.87	1.89	
			mm	203	178	256	22	48	

- Provides infinitely variable capacity and discharge pressure
- Suitable for continuous start/stop applications
- Pumps oil, water, and other fluids
- Stainless steel pump and check valves standard
- Maintains pressure with minimal power consumption (Non-load holding)
- Usable in hazardous areas: per ATEX II, CAT. 2 GDcT5
- Quiet operation
- Can operate on gases other than air
- Simple to install and maintain
- Compact, rugged design
- Only 15psi (1bar) air pressure required to start pump
- Requires flooded inlet
- Vertical mount

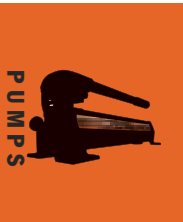

BSP FITTINGS	NPT FITTINGS	RATIO 1:	OUTLET PRESSURE		OUTPUT PER CYCLE		MAXIMUM FLOW AT ZERO PRESSURE		INLET	OUTLET
			(BAR)	(PSI)	(LITERS)	(IN ³)	(LITRES/MIN)	(IN ³ /MIN)		
PUA26B	PUA26U	4.3	26	380	0.028	1.68	14	850	1/2" BSP/NPT	1/2" BSP/NPT
PUA70B	PUA70U	11.9	70	1,010	0.01	0.607	5	305	1/2" BSP/NPT	1/2" BSP/NPT
PUA157B	PUA157U	26.7	157	2,280	0.004	5.269	2.4	146	1/2" BSP/NPT	1/2" BSP/NPT
PUA275B	PUA275U	47.5	275	3,990	0.0025	0.151	1.4	85	1/2" BSP/NPT	1/2" BSP/NPT
PUA430B	PUA430U	68.4	430	6,230	0.0017	0.105	0.9	55	1/2" BSP/NPT	1/2" BSP/NPT
PUA655B	PUA655U	107	655	9,500	0.0011	0.67	0.6	36	1/2" BSP/NPT	1/2" BSP/NPT
PUA982B	PUA982U	163.8	982	14,250	0.0007	0.044	0.4	24	1/2" BSP/NPT	1/2" BSP/NPT
PMA27B	PMA27U	4	27	390	0.16	9.72	37	2260	1" BSP/NPT	3/4" BSP/NPT
PMA60B	PMA60U	9	60	870	0.07	4.32	23	1400	1" BSP/NPT	3/4" BSP/NPT
PMA90B	PMA90U	13.6	90	1,300	0.05	2.85	15	915	1" BSP/NPT	3/4" BSP/NPT
PMA130B	PMA130U	19	130	1,880	0.034	2.04	11	670	3/4" BSP/NPT	1/2" BSP/NPT
PMA190B	PMA190U	28.4	190	2,750	0.023	1.37	7.3	455	3/4" BSP/NPT	1/2" BSP/NPT
PMA240B	PMA240U	36	240	3,480	0.018	1.08	5.8	354	3/4" BSP/NPT	1/2" BSP/NPT
PMA370B	PMA370U	54.5	370	5,360	0.012	0.71	3.8	230	1/2" BSP/NPT	1/2" BSP/NPT
PMA520B	PMA520U	76.5	520	7,540	0.008	.51	2.8	170	1/2" BSP/NPT	1/2" BSP/NPT
PMA770B	PMA770U	113	770	11,160	0.006	0.34	1.8	110	1/2" BSP/NPT	1/2" BSP/NPT
PMA980B	PMA980U	145	980	14,210	0.004	0.27	1.5	91	1/2" BSP/NPT	1/2" BSP/NPT
PMA1740B	PMA1740U	256	1,740	25,230	0.0025	0.15	0.84	51	1/2" BSP/NPT	3/8" HP
PMA2410B	PMA2410U	368	2,410	35,000	0.0017	0.104	0.58	35	1/2" BSP/NPT	3/8" HP

AIR OPERATED

PUA & PMA Series

Performance charts

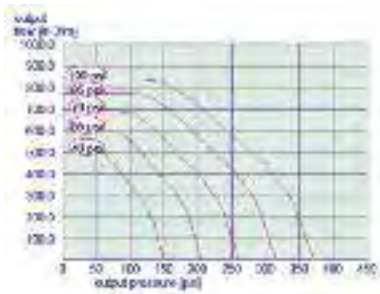

PUA-4:3:1

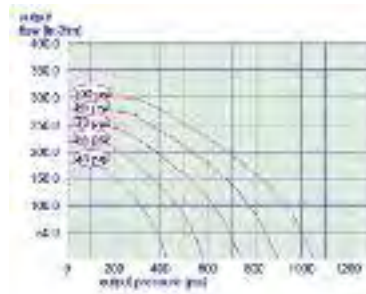

PUA-11:9:1

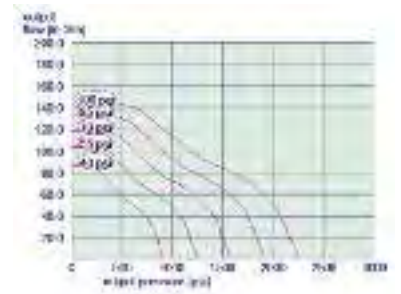

PUA-26.7:1

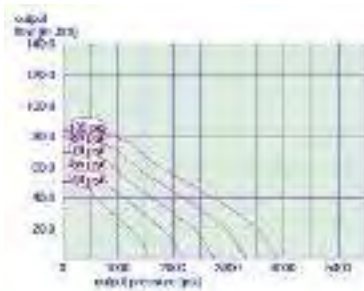

PUA-47.5:1

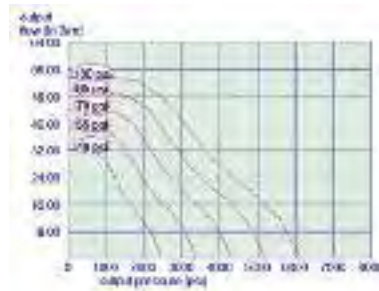

PUA-68.4:1

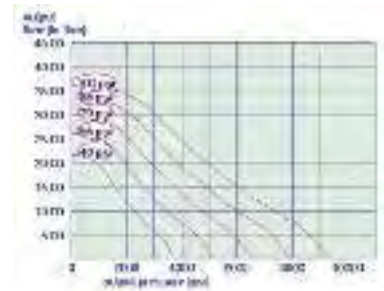

PUA-107:1

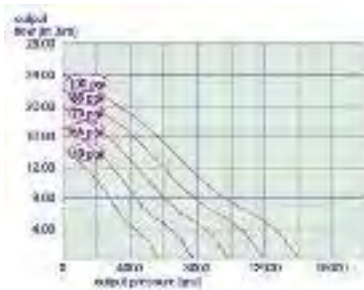

PUA-163.8:1

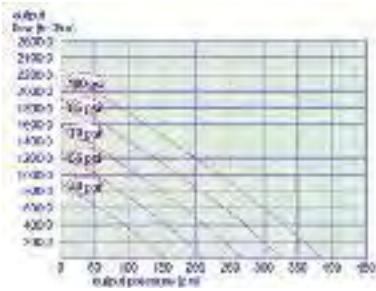

PMA-4:1

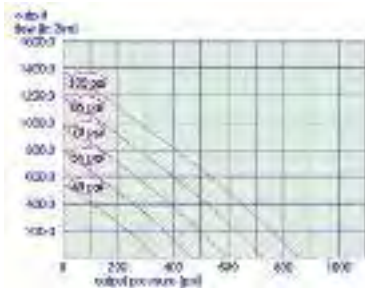

PMA-9:1

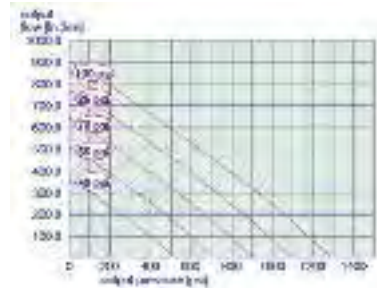

PMA-13.6:1

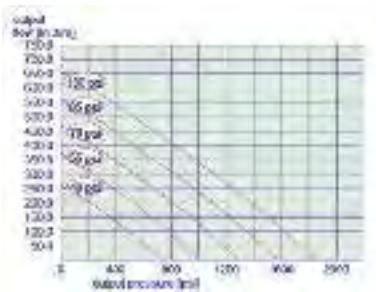

PMA-19:1

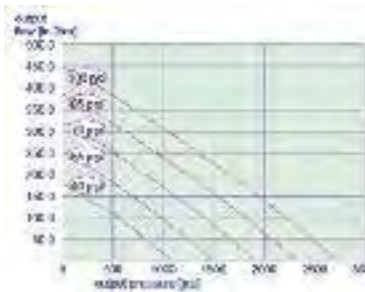

PMA-28.4:1

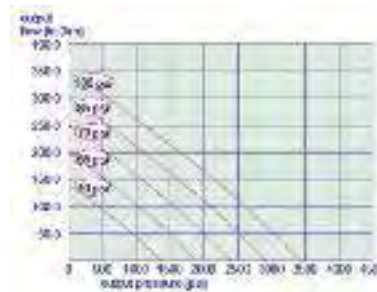

PMA-36:1

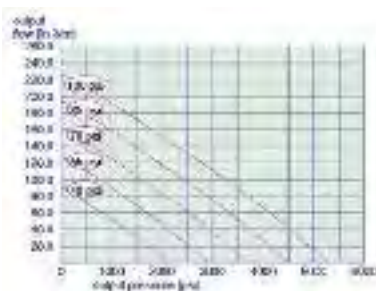

PMA-54.5:1

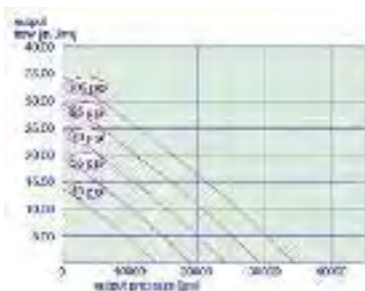

PMA-76.5:1

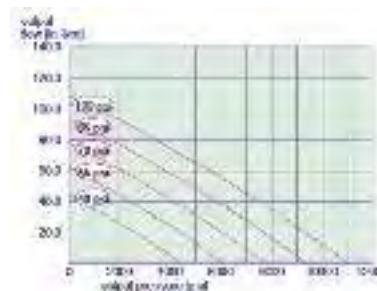

PMA-113:1

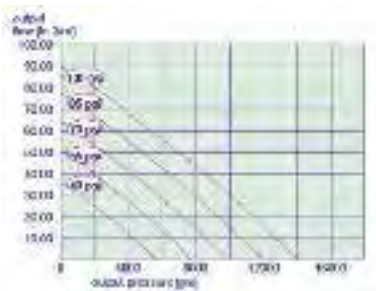

PMA-145:1

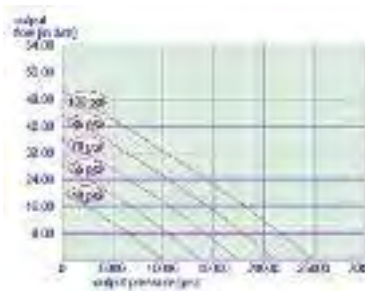

PMA-256:1

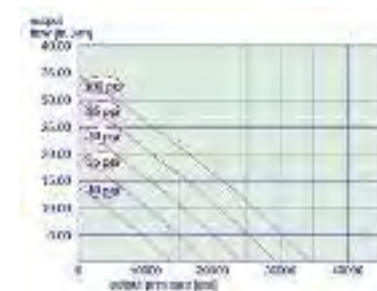

PMA-368:1



ELECTRIC/BATTERY

PE10 Series Pump

Up to 25 Ton Quarter Horse®
Two Speed

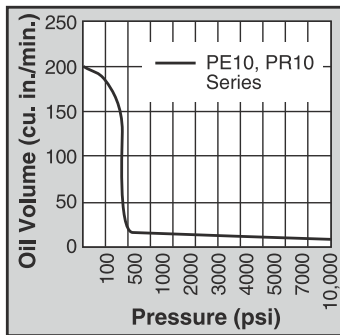

HIGH PERFORMANCE IN COMPACT PACKAGE. ELECTRIC AND BATTERY POWERED MODELS FOR POWERING TOOLS AND CYLINDERS UP TO 25 TON.

- Portable power source for hydraulic cylinders, and tools.
- Permanent magnet motor starts easily under load, even with reduced voltage conditions.
- Battery-operated models have 8 foot power cord with alligator clips to connect to any 12 volt battery.
- Optional rechargeable battery pack with shoulder strap for maximum portability.
- Pump typically delivers 15 minutes of continuous operation at 10,000 psi on a single battery.
- Pump can be operated in any position.
- 24 volt hand and foot switches available for all AC powered models.
- High-impact housing with flame-retardant construction.
- Base mounting holes for fixed installations.

For use with Cyl. Type	Description	Order No.	Valve Type	Valve No.	Valve Function	Control Switch	Motor	Reservoir Usable Cap. (cu. in.)
Single-Acting	Base model pump with 1/4 hp motor. Bladder type reservoir, 110 volt power required.	PE102	2-Way/ Auto. Dump	9561	Advance Return (Auto.)*	Rocker Type off, Momentary on	1/4 hp, 110/115V 50/60 Hz, Single Phase	60
Single-Acting	PE102, except has automatic dump valve.	PE102A	Auto. Dump	9562	Advance Return**	Rocker Type off, Momentary on	1/4 hp, 110/115V 50/60 Hz, Single Phase	60
Single-Acting	PE102, except requires 220 volt.	PE102-220	2-Way/ Auto. Dump	9561	Advance Return (Auto.)*	Rocker Type off, Momentary on	1/4 hp, 220/230V 50/60 Hz, Single Phase	60
Single-Acting	PE102A, except requires 220 volt.	PE102A-220	Auto. Dump	9562	Advance Return	Rocker Type off, Momentary on	1/4 hp, 220/230V 50/60 Hz, Single Phase	60
Single-Acting	PE102, except requires 12 volt DC.	PR102	2-Way/ Auto. Dump	9561	Advance Return (Auto.)*	Rocker Type off, Momentary on	1/4 hp, 12V†	60
Single-Acting	PE102A, except requires 12 volt DC.	PR102A	Auto. Dump	9562	Advance Return**	Rocker Type off, Momentary on	1/4 hp, 12V†	60
Single-Acting/ Double-Acting	Base model pump has 4-way valve for operating double-acting systems. 110 volt power required.	PE104	4-Way	9563	Advance Hold Return	Rocker Type off, Momentary on	1/4 hp, 110/115V 50/60 Hz, Single Phase	60
Single-Acting/ Double-Acting	PE104, except requires 220 volt.	PE104-220	4-Way	9563	Advance Hold Return	Rocker Type off, Momentary on	1/4 hp, 220/230V 50/60 Hz, Single Phase	60
Single-Acting/ Double-Acting	PE104, except requires 12 volt DC.	PR104	4-Way	9563	Advance Hold Return	Rocker Type off, Momentary on	1/4 hp, 12V†	60

* "Advance" position holds pressure with motor shut off. "Return" position advances cylinder with motor running and returns cylinder with motor shut off.

** Cylinder advances with motor running and automatically returns with motor shut off.

† Comes with an 8 ft. alligator clip cord for 12 volt DC use.



PE104

10,000 psi



The Quarter Horse pump has a maximum operating pressure of 10,000 psi, which handles a wide variety of handheld hydraulic tools.

Accessories



BP212VQ

BP212VQ – Optional 12 volt battery pack. Includes sealed lead acid battery, 115V charger, 4 ft. cord, carrying case and shoulder strap. Wt., 17.7 lbs.



BC 212

BC212 – Battery charger for U.S.A. Wt., 6.6 lbs.

BC212EUR – Battery charger for Europe. Wt., 6.6 lbs.

25017 – Remote hand control with 10 ft. cord. Wt., 0.8 lb.

RB12V – Battery only.

BP12INT – Battery with cord and carrying case. Wt., 11.1 lbs.

RC12V – Replacement 4 ft. battery cord only. Wt., .5 lbs.

Max. Pump No.	dBa @ Pressure Output (psi)	Idle and 10,000 (psi)	Oil Del. (cu. in./min. @)		Overall Dimensions	Prod. Wt. with Oil (lbs.)
			0-40 (psi)	10,000 (psi)		
PE10 Series	10,000	68-74*	120	10	13"L x 7 ³ / ₄ "W x 8"H	20
PR10 Series						

* Measured at 3 ft. distance, all sides.

NOTE: PR10 rechargeable model is equipped with 8 ft. cord with alligator clips. Order optional battery pack (No. BP212VQ) or use with any 12 volt battery.

NOTE: Amp draw at 10,000 psi; 6 amp at 115 volt, 3 amp at 230 volt, and 35 amp at 12 volt.



9560 – Pressure regulator. Adjustable from 1,000 to 10,000 psi. All mounting hardware included. Wt., 3 lbs.



251660 – Foot switch with 10 ft. cord. Single pole, double throw, 15 amp @ 125-250 VAC. Wt., 1 lb.

ELECTRIC PUMP

Hydraulic PE17 Series

Up to 55 Ton

17 cu. in./min. 2 Speed

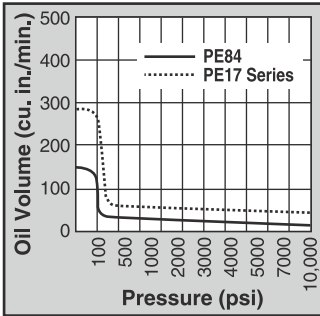

FOR MAINTENANCE AND CONSTRUCTION APPLICATIONS.

- For use with single-acting or double-acting cylinders at operating pressures to 10,000 psi.
- For intermittent duty; starts under full load.
- Equipped with ½ hp, 3,450 rpm, single-phase, thermal protected induction motor; 10 ft. remote control cord (PE172S has 25 ft. cord)
- Low amperage draw; small generators and low amperage circuits can be used as power source.
- Extremely quiet noise level (67-81 dBA).



10,000 psi

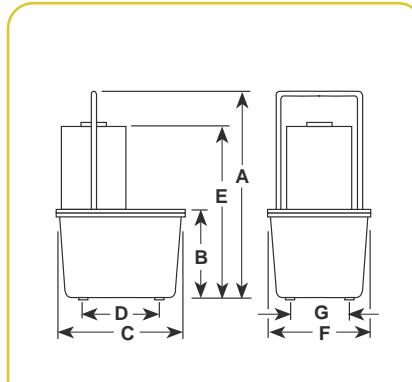

Pump No.	Max. Pressure Output (psi)	rpm	dBa at Idle and 10,000 (psi)	Amp Draw 115 V - at 10,000 (psi)	Oil Del. (cu. in./min. @) †				Dimensions							Prod. Wt. with Oil (lbs.)
					0 (psi)	100 (psi)	5,000 (psi)	10,000 (psi)	A (in.)	B (in.)	C (in.)	D (in.)	E (in.)	F (in.)	G (in.)	
PE17 Series	10,000	3,450	67/81*	10	290	190	20	16	18½	7	11¾	7½	14⅞	9¼	5⅞	45
PE17M Series	10,000	3,450	67/81*	10	290	190	20	16	18⅞	6⅝	11½	—	14½	9½	—	53

* Measured at 3 ft. distance, all sides.

† Typical delivery. Actual flow will vary with field conditions.

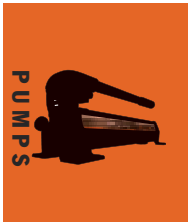

For use with Cyl. Type	Description	Order No.	Valve Type	Valve No.	Valve Function	Control Switch ††	Motor	Reservoir Usable (cu. in.)
Single-Acting	Base model pump with 1/2 hp pump with 2 gal. thermoplastic reservoir.	PE172	2-Way	9517	Advance Return (Auto†)	Remote Motor Control (10ft.) on/off	1/2 hp, 110/115V* 50/60 Hz, Single Phase	295
Single-Acting	PE172, except has 2 1/2 gal. aluminum reservoir.	PE172M	2-Way	9517	Advance Return (Auto†)	Remote Motor Control (10ft.) on/off	1/2 hp, 110/115V* 50/60 Hz, Single Phase	375
Single-Acting	PE172, has solenoid operated valve.	PE172S	3-Way	9579	Advance Hold Return	Remote Motor & Valve (25 ft.)	1/2 hp, 110/115 VAC 50/60 Hz, Single Phase	295
Single-Acting	PE172S, except has aluminum reservoir.	PE172SM	3-Way	9579	Advance Hold Return	Remote Motor & Valve (25 ft.)	1/2 hp, 110/115 VAC 50/60 Hz, Single Phase	375
Single-Acting	Best suited for crimping, punching, pressing. Not for lifting. Thermoplastic reservoir.	PE172A ∞	Auto./Dump Manifold	45554	Advance Return	Remote Motor Control (10ft.) on/off	1/2 hp, 110/115V* 50/60 Hz, Single Phase	295
Single-Acting	PE172A, except has aluminum reservoir.	PE172AM ∞	Auto./Dump Manifold	45554	Advance Return	Remote Motor Control (10ft.) on/off	1/2 hp, 110/115V* 50/60 Hz, Single Phase	375
Single/ Double-Acting	PE172, except has 9500 double-acting valve.	PE174	4-Way	9500	Advance Hold Return**	Remote Motor Control (10ft.) on/off	1/2 hp, 110/115V* 50/60 Hz, Single Phase	295
Single/ Double-Acting	Same as PE174, except has aluminum reservoir.	PE174M	4-Way	9500	Advance Hold Return**	Remote Motor Control (10ft.) on/off	1/2 hp, 110/115V* 50/60 Hz, Single Phase	375

* Available with 220 V., 50 Hz motor (to order, place suffix "50-220" behind pump order number).

** "Advance" position holds pressure with motor shut off.

† "Advance" position holds pressure with motor shut off. "Return" position advances cylinder with motor running and returns cylinder with motor shut off.

†† Control switch on PE17 series wired with line voltage.

∞ Not to be used for lifting.

NOTE: The remote motor control switch on 220V., 50 cycle PE17 series pumps is 24 volt.

NOTE: Usable oil is calculated with the oil fill at the recommended level of 1 1/2" below reservoir cover plate.

‡Some Power Team pumps are available in special configurations not listed in this catalog. Power Team can "Assemble to Order" pumps with special seals, voltages, valves, relief valve settings, etc. For your special requirements please consult your local distributor or the Power Team factory.

ELECTRIC PUMP

Hydraulic PE18 Series

Up to 55 Ton 18 cu. in./min.

Vanguard Jr. Series®

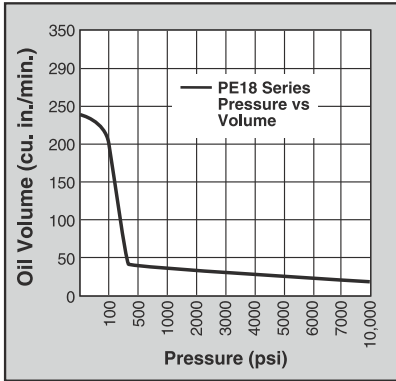

IDEAL FOR USE WITH SMALL HYDRAULICALLY POWERED TOOLS.

- Vanguard Jr.® pumps provide two-speed high performance in a light-weight, compact package.
- Gauge port provided on pump. Metal reservoir on all models.
- Equipped with a ½ hp, 115 volt, 60/50 Hz single phase motor that starts under load, even at reduced voltage.
- Low amperage draw permits use with smaller generators and low amperage circuits.
- All pumps have a 10 foot remote control (PE183C has 25 foot remote control).
- CSA rated for intermittent duty. Noise level of 85-90 dBA.

PE182



For operating hydraulic crimping, cutting or other tools:

- **No. PE183C** - For crimping or pressing applications. Has special electrical circuitry to pulse/advance, hold at full pressure, build to a predetermined pressure, release and reset circuit. Features separate emergency return switch.
- **No. PE184C** - Allows you to alternately operate a spring-return cutting and/or crimping tool without disconnecting either tool. Select port connection with manual 4-way valve, start pump with remote control hand switch and extend connected tool. When hand switch is switched to off, pump stops and automatic valve opens, allowing tool to return. In center (neutral) position, manual control valve holds tool in position at time valve is shifted.

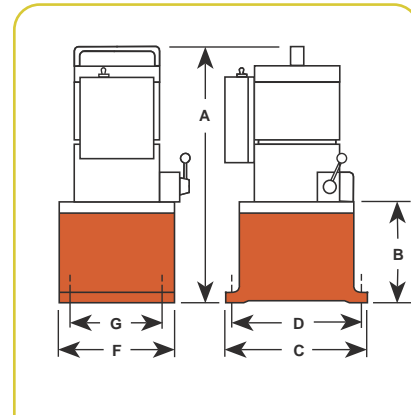

10,000 psi



Pump No.	Max. Pressure Output (psi)	rpm	dBA at Idle and 10,000 (psi)	Amp Draw 115 V at 10,000 (psi)	Oil Del. (cu. in./min. @)†				A (in.)	B (in.)	C (in.)	D (in.)	E (in.)	F (in.)	G (in.)	Prod. Wt. with Oil (lbs.)
					0 (psi)	100 (psi)	5,000 (psi)	10,000 (psi)								
PE182	10,000	12,000	85/90**	10.2 Amps	230	190	25	18	16	4 ³ / ₄	8	7 ¹ / ₈	6	5 ¹ / ₈	30	
PE183	10,000	12,000	85/90**	10.2 Amps	230	190	25	18	16	4 ³ / ₄	8	7 ¹ / ₈	6	5 ¹ / ₈	30	
PE183A	10,000	12,000	85/90**	10.2 Amps	230	190	25	18	16	4 ³ / ₄	8	7 ¹ / ₈	6	5 ¹ / ₈	30	
PE184	10,000	12,000	85/90**	10.2 Amps	230	190	25	18	16	4 ³ / ₄	8	7 ¹ / ₈	6	5 ¹ / ₈	30	
PE183-2*	10,000	12,000	85/90**	10.2 Amps	230	190	25	18	18 ¹ / ₂	7 ¹ / ₄	11 ¹ / ₂	10	9 ¹ / ₂	8	42	
PE184-2*	10,000	12,000	85/90**	10.2 Amps	230	190	25	18	18 ¹ / ₂	7 ¹ / ₄	11 ¹ / ₂	10	9 ¹ / ₂	8	42	
PE183C ††	10,000	12,000	85/90**	10.2 Amps	230	190	25	18	16	4 ³ / ₄	12 ¹ / ₄	7 ¹ / ₈	7	5 ¹ / ₈	30	
PE184C ††	10,000	12,000	85/90**	10.2 Amps	230	190	25	18	16	4 ³ / ₄	8	7 ¹ / ₈	6	5 ¹ / ₈	30	

* 2¹/₂ gal. reservoir.

** Measured at 3 ft. distance, all sides.

† Typical delivery. Actual flow will vary with field conditions.

†† Special application pumps for cutting, crimping or pressing.

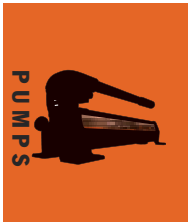

For use with Cyl. Type	Description	Order No.	Valve Type	Valve Function	Control Switch ^{††}	Motor	Reservoir Usable (cu. in.)
Single-Acting	Base model pump has 1/2 hp pump with 2-Way valve and 1/2 gal. reservoir.	PE182	2-Way	Advance Return [†]	Remote Motor Control (10 ft.) on/off	1/2 hp, 110/115VAC** 50/60 Hz, A.C., Single Phase	104
Single-Acting	PE182, except has 3-way valve.	PE183	3-Way	Advance Hold Return	Remote Motor Control (10 ft.) on/off	1/2 hp, 110/115VAC** 50/60 Hz, A.C., Single Phase	104
Single-Acting	PE183, except has 2 gal. reservoir.	PE183-2	3-Way	Advance Hold Return	Remote Control (10 ft.)	1/2 hp, 110/115VAC** 50/60 Hz, A.C., Single Phase	525 ^{††}
Single-Acting	PE183, except has "dump valve".	PE183A [∞]	Auto./Dump Pump	Advance Return	Remote (10 ft.)	1/2 hp, 110/115VAC** 50/60 Hz, A.C., Single Phase	104
Single-Acting	Special crimping pump.	PE183C [∞]	Special, for crimping only	Advance Hold Return	Remote Motor Control (25 ft.) on/off	1/2 hp, 110/115VAC** 50/60 Hz, A.C., Single Phase	104
Single-Acting/ Double-Acting	Base model pump has 1/2 hp pump for double-acting systems with 1/2 gal. reservoir.	PE184	4-Way	Advance Hold Return [†]	Remote Motor Control (10 ft.) on/off	1/2 hp, 110/115VAC** 50/60 Hz, A.C., Single Phase	104
Single-Acting/ Double-Acting	PE184, except with 2 gal. reservoir.	PE184-2	4-Way	Advance Hold Return [†]	Remote Motor Control (10 ft.) on/off	1/2 hp, 110/115VAC** 50/60 Hz, A.C., Single Phase	525 ^{††}
Single-Acting/ Double-Acting	Special crimping pump.	PE184C [*]	4-Way	Advance Return	Remote Control (10 ft.) on/off	1/2 hp, 110/115VAC** 50/60 Hz, A.C., Single Phase	104

* Also for use with special single-acting cylinder applications.
 ** Available with 220 Volt, 60/50 Hz motor (to order, place suffix "50-220" behind pump order number). Specify voltage when ordering.

[†] Holds when motor is shut off and valve is in "advance" position.
^{††} Pumps supplied with 2 gal. oil (usable oil is 355 cu. in.), will hold 2 1/2 gal. when filled to within 1/2" below reservoir cover plate.
[∞] Not to be used for lifting.

ELECTRIC PUMP

PE21 Series

Up to 75 Ton 22 cu. in./min.
Two-Speed

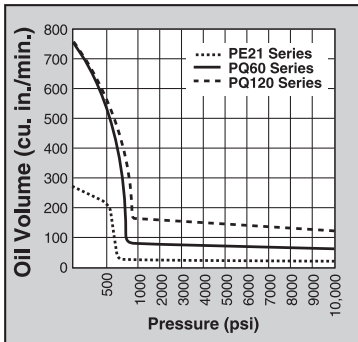

- Totally enclosed, fan cooled induction motor: 1 hp, 1,725 rpm, 60 Hz, single phase. Thermal overload protection.
- Remote control, with 10 foot cord is standard on pumps with solenoid valves. Manual valve pumps have “Stop”, “Start” and “Run/Off/Pulse” switches. Pump controls are moisture and dust resistant.
- Motor drip cover with carrying handles and lifting lug.
- Low noise level of 70 dBA@ 10,000 psi.
- In the event of electrical interruption, pump shuts off and will not start up until operator presses the pump start button.
- 24 volt control circuits on units with remote controls provide additional user/operator safety.



PE213



PE21 series pump and RD5513 cylinder used in a special press that produces pharmaceutical-grade extracts for herbal medicines.

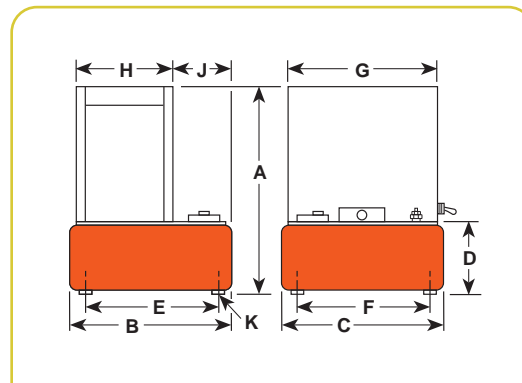

Pump No.	Max. Pressure Output		dBa at Idle and 10,000 (psi)	Oil Del. (cu. in./min. @)†				Dimensions						Prod. Wt. w/Oil (lbs.)				
	(psi)	rpm		100 (psi)	1,000 (psi)	5,000 (psi)	10,000 (psi)	A (in.)	B (in.)	C (in.)	D (in.)	E (in.)	F (in.)		G (in.)	H (in.)	J (in.)	K*** (in.)
PE21 Series	10,000	1,725	70*	270	29	27	22	21 ³ / ₈	11 ¹ / ₂	9 ¹ / ₂	6 ¹ / ₂	10	8	14 ¹ / ₈	9 ¹ / ₂	3 ³ / ₄	1/2-20 UNF	98†

* Measured at a 3 ft. distance, all sides.

*** For 2" dia. swivel casters, order (4) No. 10494.

† Shipping weight with manual valve; add 14 lbs. for pump with solenoid valve.



PE214

10,000 psi



PE214S

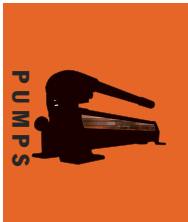

For use with Cyl. Type	Description	Order No.	Valve Type	Valve No.	Valve Function	Max. Amp Draw @ 10,000 (psi)	Motor	Reservoir Usable (cu. in.)
Single-Acting	1 h.p. pump with 2½ gal. reservoir and manual valve.	PE213	3-Way	9520*	Advance Hold Return	115V - 15 amps 230 V - 7.5 amps	1 hp, 115/230 Volt 60 Hz††, Single Phase	590
Single-Acting	PE213, except has solenoid operated remote valve.	PE213S	3-Way	9599†	Advance Hold Return	115V - 15 amps 230 V - 7.5 amps	1 hp, 115/230 Volt 60 Hz††, Single Phase	590
Double-Acting	1 h.p. pump with 2½ gal. reservoir and manual valve.	PE214	4-Way	9506*	Advance Hold Return	115V - 15 amps 230 V - 7.5 amps	1 hp, 115/230 Volt 60 Hz††, Single Phase	590
Double-Acting	PE214, except has solenoid operated remote valve.	PE214S	4-Way	9512†	Advance Hold Return	115V - 15 amps 230 V - 7.5 amps	1 hp, 115/230 Volt 60 Hz††, Single Phase	590

* Manual valve. Pump is equipped with RUN/OFF/PULSE switch for control of motor.

† Solenoid valve. Pump is equipped with a remote control switch with 10 ft. cord.

†† Prewired at factory for this voltage. PE21 series available in 230V 60Hz or 220V 50Hz. Please specify when ordering. Example: for 60Hz order PE213-230; for 50Hz order PE213-50-220.

Some Power Team pumps are available in special configurations not listed in this catalog. Power Team can “Assemble to Order” pumps with special seals, voltages, valves, relief valve settings, etc. For your special requirements please consult your local distributor or the Power Team factory.

ELECTRIC PUMP

Hydraulic PED Series

25 cu. in./min. Two-Speed

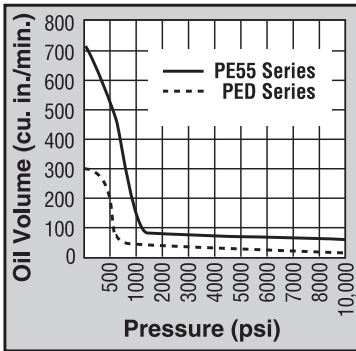

IDEAL FOR RUNNING MULTIPLE TOOLS OR CYLINDERS FROM ONE POWER UNIT. RECOMMENDED FOR CYLINDERS UP TO 75 TONS.

- Two-speed pumps have the same low pressure and high pressure flows from both valves.
- Flows and pressures of each pump are independent.
- Delivers 300 cu. in./min. of oil @ 100 psi and 25 cu. in./min. @ 10,000 psi from each pump.
- 1½ hp, 110/115 volt, 60 Hz induction motor, 10 foot remote control and 5 gallon steel reservoir.
- Models available for operating single-acting or double-acting cylinders.
- Each power unit contains two separate pumps and two separate valves allowing operator to control multiple processes with one power unit.
- Both pumps on each power unit are equipped with an externally adjustable pressure relief valve.
- Not recommended for frequent starting and stopping.



PED253

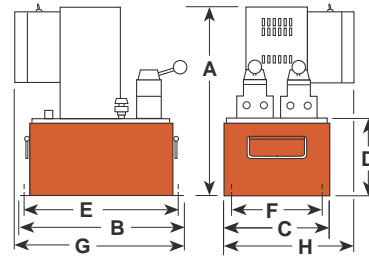

Pump No.	Max. Pressure Output (psi)	rpm	dBa at 10,000 (psi)	(115v)** Amp Draw at 10,000 (psi)	Oil Del. (cu. in./min. @)				Dimensions								Prod. Wt. w/Oil (lbs.)
					100 (psi)	700 (psi)	5,000 (psi)	10,000 (psi)	A (in.)	B (in.)	C (in.)	D (in.)	E (in.)	F (in.)	G (in.)	H (in.)	
PED Series	10,000	3,450	87/85*	22	300	40	35	25	20¾	18	11½	8½	16½	9	18	13	170

* Noise level reading (dBA) measured at a 3 ft. distance, all sides.

** Amp draw at 10,000 psi, 230 Volts 50/60 Hz is 15 Amps.

10,000 psi



PED254



PED254S

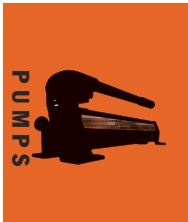

For use with Cyl. Type	Description	Order No.	Valve Type	Valve No.	Valve Function	Control Switch	Motor	Reservoir Usable (cu. in.)
Single-Acting	1½ hp pump with 5 gal. reservoir. Valve has "Posi-Check" feature.	PED253	3-Way	9520	Advance Hold Return	Remote Motor	1½ hp, 115/230 VAC 60 Hz, Single Phase	1,000
Double-Acting	1½ hp pump with 5 gal. reservoir. Valve has "Posi-Check" feature.	PED254	4-Way	9506	Advance Hold Return	Remote Motor	1½ hp, 115/230 VAC 60 Hz, Single Phase	1,000
Double-Acting	PED254, except has solenoid operated remote valve.	PED254S	4-Way	9513	Advance Hold Return	Remote Valve	1½ hp, 115/230 VAC 60 Hz, Single Phase	1,000

All remotes are 10 ft. long.

ELECTRIC PUMP

PE30 Series

30 cu. in./min. Two-Speed
Vanguard® Series

IDEAL FOR MAINTENANCE AND CONSTRUCTION APPLICATIONS

- Deliver a powerful punch to operate single-acting or double-acting cylinders.
- Integral roll cage protects pump from abuse.
- 1 hp, single phase, permanent magnet motor.
- High performance to weight ratio.
- Starts under full load even when voltage is reduced to 50% of nominal rating.
- Quiet operation: 82 dBA @ 10,000 psi and 87 dBA @ 0 psi. CSA rated for intermittent duty.
- Remote controls and/or solenoid valves feature 24 volt controls.

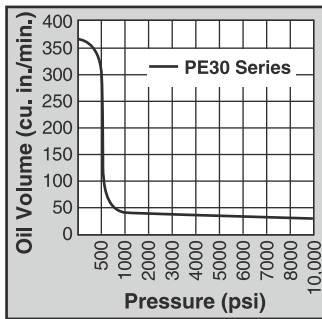

PE302S

PE30TWP
Torque Wrench
Applications
See page 174

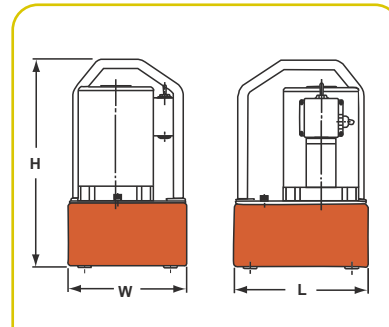

Pump No.	Max. Pressure Output (psi)	dBA at Idle & 10,000 (psi)	Amp Draw 115V at 10,000 (psi)	Oil Del. (cu. in./min. @)					Overall Dimensions	Prod. Wt. With Oil (lbs.)
				100 (psi)	500 (psi)	1,000 (psi)	5,000 (psi)	10,000 (psi)		
PE30 Series w/1¼ gal. res.	10,000	87/82	13	300	200	44	38	30	10"L x 9"W x 16"H	41
PE30 Series w/1¾ gal. res.	10,000	87/82	13	300	200	44	38	30	13½"L x 9½"W x 16½"H	49



10,000 psi



PE302

See current price list for shipping weights.

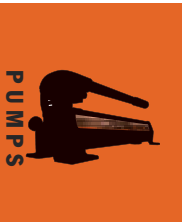

For Use with Cyl. Type	Description	Order No.	Valve Type	Valve No.	Valve Function	Control Switch	Motor (4,000 rpm)	Reservoir Usable (cu. in.)
Single-Acting	Base model 1 hp pump with 1¼ gal. reservoir & 2 position valve.	PE302	3-Way, 2 Pos.	9584	Hold Advance Return	On/Off/Pulse Switch	1 hp 110/115 VAC, 50/60 Hz, Single Phase	280**
Single-Acting	PE302, except has 1¼ gal. reservoir.	PE302-2	3-Way, 2 Pos.	9584	Hold Advance Return	On/Off/Pulse Switch	1 hp 110/115 VAC, 50/60 Hz, Single Phase	380***
Single-Acting	PE302, except has remote motor control.	PE302R	3-Way, 2 Pos.	9584	Hold Advance Return	Remote Motor Control (10 ft.)	1 hp 110/115 VAC, 50/60 Hz, Single Phase	280**
Single-Acting	PE302R, except has 1¼ gal. reservoir.	PE302R-2	3-Way, 2 Pos.	9584	Hold Advance Return	Remote Motor Control (10 ft.)	1 hp 110/115 VAC, 50/60 Hz, Single Phase	380***
Single-Acting	PE302R, except also has solenoid operated remote valve.	PE302S†	3-Way, 2 Pos.	9579	Hold Advance Return	Remote Motor & Valve (10 ft.)	1 hp 110/115 VAC, 50/60 Hz, Single Phase	280**
Single-Acting	PE302S, except has 1¼ gal. reservoir.	PE302S-2†	3-Way, 2 Pos.	9579	Hold Advance Return	Remote Motor & Valve (10 ft.)	1 hp 110/115 VAC, 50/60 Hz, Single Phase	380***
Single-Acting	PE302, except has "Auto Dump" valve	PE302A∞	Auto Dump	9610	Automatic Pilot Operation	Remote Motor Control (10 ft.)	1 hp 110/115 VAC, 50/60 Hz, Single Phase	280**
Single-Acting	Base model 1 hp pump with 1¼ gal. reservoir & 3 position valve.	PE303	3-Way, 3 Pos.	9520*	Advance Hold Return	On/Off/Pulse Switch	1 hp 110/115 VAC, 50/60 Hz, Single Phase	280**
Single-Acting	PE303, except has 1¼ gal. reservoir.	PE303-2	3-Way, 3 Pos.	9520*	Advance Hold Return	On/Off/Pulse Switch	1 hp 110/115 VAC, 50/60 Hz, Single Phase	380***
Single-Acting	PE303, except has remote motor control.	PE303R	3-Way, 3 Pos.	9520*	Advance Hold Return	Remote Motor Control (10 ft.)	1 hp 110/115 VAC, 50/60 Hz, Single Phase	280**
Single-Acting	PE303R, except has 1¼ gal. reservoir.	PE303R-2	3-Way, 3 Pos.	9520*	Advance Hold Return	Remote Motor Control (10 ft.)	1 hp 110/115 VAC, 50/60 Hz, Single Phase	380***
Double-Acting	Base model 1 hp pump with 1¼ gal. reservoir & 4-way valve for double-acting systems	PE304	4-Way, 3 Pos. Tandem Ctr.	9506*	Advance Hold Return	On/Off/Pulse Switch	1 hp 110/115 VAC, 50/60 Hz, Single Phase	280**
Double-Acting	PE304, except has 1¼ gal. reservoir.	PE304-2	4-Way, 3 Pos. Tandem Ctr.	9506*	Advance Hold Return	On/Off/Pulse Switch	1 hp 110/115 VAC, 50/60 Hz, Single Phase	380***
Double-Acting	PE304, except has remote motor control.	PE304R	4-Way, 3 Pos. Tandem Ctr.	9506*	Advance Hold Return	Remote Motor Control (10 ft.)	1 hp 110/115 VAC, 50/60 Hz, Single Phase	280**
Double-Acting	PE304R, except has 1¼ gal. reservoir.	PE304R-2	4-Way, 3 Pos. Tandem Ctr.	9506*	Advance Hold Return	Remote Motor Control (10 ft.)	1 hp 110/115 VAC, 50/60 Hz, Single Phase	380***

* "Posi-Check" valve design, "Posi-Check" guards against pressure loss when valve is shifted from "advance" to "hold" position.

** Shipped with 1 gal. of oil (231 cu. in., 210 usable).

*** Shipped with 2 gal. of oil.

∞ Not to be used for lifting applications. Best suited for crimping, pressing & punching applications.

† 115 volt, 60 Hz.

†† For 220/230 volt, 50/60 Hz. add suffix "- 220" (example PE302-220).

ELECTRIC PUMP

PE46 Series

46 cu. in./min.
Two-speed

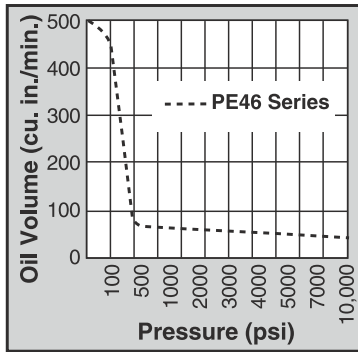

BEST SUITED FOR UNDER-THE-ROOF MAINTENANCE AND PRODUCTION APPLICATIONS.

- Two-speed high performance pump.
- For use with single- or double-acting cylinders at operating pressures to 10,000 psi.
- Equipped with a 1½ hp, 3,450 rpm single-phase, 60 Hz thermal protected induction motor that starts under full load. Noise level of 77-81 dBA.
- All equipped with a 10 foot remote control except PE462S which has a 25 foot remote control.
- 24 volt control circuit on all units with remote control.
- CSA rated for intermittent duty.



PE462A

10,000 psi

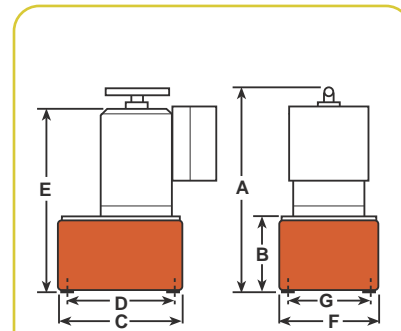

Pump No.	Max. Pressure Output (psi)	rpm	dBa at Idle and 10,000 (psi)	Amp Draw 115 V - at 10,000 (psi)	Oil Del. (cu. in./min. @)†				Dimensions (in.)							Prod. Wt. w/Oil (lbs.)
					0 (psi)	100 (psi)	5,000 (psi)	10,000 (psi)	A	B	C	D	E	F	G	
PE46 Series	10,000	3,450	77/81*	25**	500	450	51	46	19 ⁵ / ₈	6 ¹³ / ₁₆	11 ¹ / ₂	10	18 ¹ / ₂	9 ¹ / ₂	8	79

* Measured at 3 ft. distance, all sides.
 ** Requires 20 amp circuit.
 † Typical delivery. Actual flow will vary with field conditions.



PE462S



PE464

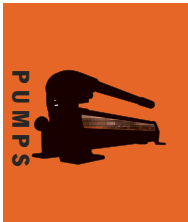

For use with Cyl. Type	Description	Order No.	Valve Type	Valve No.	Valve Function	Control Switch	Motor	Reservoir Usable (cu. in.)
Single-Acting	Base model 1½ hp pump with 2½ gal. metal reservoir.	PE462	3-Way	9584	Advance Return†	Remote Motor Control (10 ft.) on/off	1½ hp, 115/230 VAC* 60 Hz, Single Phase	590
Single-Acting	PE462, except has solenoid valve.	PE462S††	3-Way	9579	Advance Return**	Remote Motor Valve (25 ft.)	1½ hp, 115/230 VAC* 60 Hz, Single Phase	590
Single-Acting	PE462, except has "dump valve"	PE462A∞	Auto/Dump 3-Way	9610	Advance Return	Remote Motor Control (10 ft.) on/off	1½ hp, 115/230 VAC* 60 Hz, Single Phase	590
Double-Acting/ Multi-Single Acting	PE462, except has 9500 double-acting valve.	PE464	4-Way	9500	Advance Hold Return†	Remote Motor Control (10 ft.) on/off	1½ hp, 115/230 VAC* 60 Hz, Single Phase	590
Double-Acting/ Multi-Single Acting	PE462S, except has 9592 double-acting valve.	PE464S††	3/4-Way	9592	Advance Return**	Remote Motor/Valve (10 ft.)	1½ hp, 115/230 VAC* 60 Hz, Single Phase	590

* Available with 220 V., 50 Hz motor (to order, place suffix "50-220" behind pump order number). Specify voltage when ordering.

** "Advance" position holds pressure with motor shut off.

*** Usable oil is calculated with the oil fill at the recommended level of ½" below reservoir cover plate.

† "Advance" position holds pressure with motor shut off. "Return" position returns cylinder.

†† 115 volt, 60 Hz.

††† The remote motor control switch on PE46 series pumps is 24 volt.

∞ Not to be used for lifting. When pump is shut off, oil returns to reservoir.

Contact Factory for special 12VDC version for service vehicles

ELECTRIC PUMP

PE55 Vanguard®

55 cu. in./min.

For cylinders up to 200 tons.



HEAVY DUTY MULTIPLE-APPLICATIONS PUMP. HEAVY CONSTRUCTION AND CONCRETE STRESSING. LOW VOLTAGE STARTING POSSIBLE.

- 1½ hp, 12,000 rpm, 110/115 volt, 50/60 Hz universal motor; draws 25 amps at full load, starts at reduced voltage. CSA rated for intermittent duty.
- 10 foot remote motor control (except PE552S which has a 25 foot remote motor and valve control).
- True unloading valve achieves greater pump efficiency, allowing higher flows at maximum pressure.
- Reservoirs available in sizes up to 10

gallons. See accessories page 133.

- Light weight and portable. Best weight to performance ratio of all Power Team pumps.
- “Assemble to Order” System: There are times when a custom pump is required. Power Team’s “Assemble to Order” system allows you to choose from a wide range of pre-engineered, off-the-shelf components to build a customized pump to fit specific requirements. By selecting standard components you get a “customized” pump without “customized” prices. All pumps come fully assembled, less oil and ready for work. See pages 100-103.

PE55TWP
Torque Wrench
Applications
See page 175



PE554W
Weather-resistant model

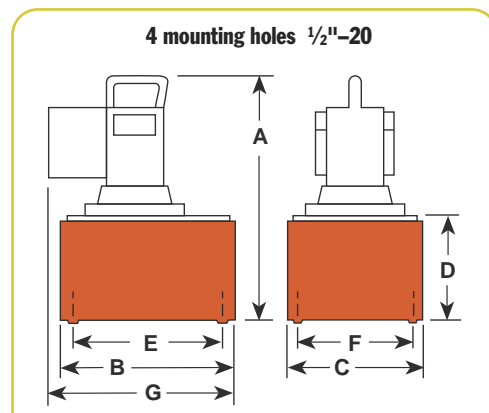
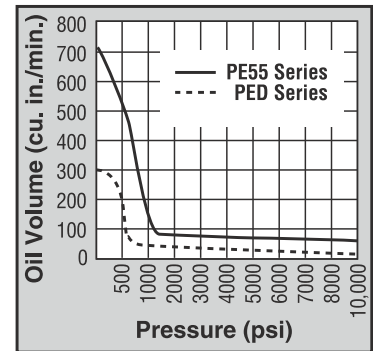

Pump No.	Max. Pressure Output (psi)	rpm	dBa at Idle and 10,000 (psi)	Amp Draw at 10,000 psi (115 V.)**				Oil Del. (cu. in./min. @)				A (in.)	B (in.)	C (in.)	D (in.)	E (in.)	F (in.)	G (in.)	H (in.)	Prod. Wt. w/Oil (lbs.)
				0 (psi)	700 (psi)	5,000 (psi)	10,000 (psi)	0 (psi)	700 (psi)	5,000 (psi)	10,000 (psi)									
PE55 Series	10,000	12,000	90/89*	25	704	440	56	18¼	11½	9½	7	10	8	14	-	-	-	-	65	

*Noise level reading (dBa) measured at a 3 ft. distance, all sides.

** Amp draw at 10,000 psi, 230 Volts 50/60 Hz is 15 Amps.

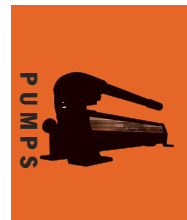

For use with Cyl. Type	Description	Order No.***	Valve Type	Valve No.	Valve Function	Control Switch††	Motor	Reservoir Usable (cu. in.)
Single-Acting	Base model 1 ¹ / ₈ hp pump with 2 ¹ / ₂ gal. reservoir, remote motor control & 3-way valve.	PE552	3-Way	9582	Advance Return**	Remote Motor	1 ¹ / ₈ hp*, 110/115 VAC 50/60 Hz, Single Phase	525
Single-Acting	PE552, except also has solenoid operated remote valve.	PE552S	3-Way	9579	Advance Hold Return	Remote Motor & Valve	1 ¹ / ₈ hp*, 110/115 VAC 50/60 Hz, Single Phase	525
Single-Acting	PE552, except has "Auto Dump" valve.	PE552A ∞	Auto/Dump	9610	Advance Return	Remote Motor	1 ¹ / ₈ hp*, 110/115 VAC 50/60 Hz, Single Phase	525
Single-Acting	1 ¹ / ₈ hp pump with 2 ¹ / ₂ gal. reservoir. Valve has "Posi-check" feature.	PE553	3-Way†	9520	Advance Hold Return	Remote Motor	1 ¹ / ₈ hp*, 110/115 VAC 50/60 Hz, Single Phase	525
Double-Acting	Base model 1 ¹ / ₈ hp pump with 2 ¹ / ₂ gal. res. and 4-way valve for double-acting systems.	PE554	4-Way†	9506	Advance Hold Return	Remote Motor	1 ¹ / ₈ hp*, 110/115 VAC 50/60 Hz, Single Phase	525
Double-Acting	Weather-resistant model 1 ¹ / ₈ hp pump with 2 ¹ / ₂ gal. res. and 4-way valve for double-acting systems.	PE554W	4-Way†	9506	Advance Hold Return	Remote Motor	1 ¹ / ₈ hp*, 110/115 VAC 50/60 Hz, Single Phase	525
Double-Acting	PE554, except has 9500 tandem center valve.	PE554T	4-Way	9500	Advance Hold Return	Remote Motor	1 ¹ / ₈ hp*, 110/115 VAC 50/60 Hz, Single Phase	525
Double-Acting	For use with single-acting Spring Seat, Stressing Jack or double-acting cylinder.	PE554P	4-Way	9500	Advance Hold Return	Remote Motor	1 ¹ / ₈ hp*, 110/115 VAC 50/60 Hz, Single Phase	525
Double-Acting	For use with single-acting or double-acting Power Seat, Stressing Jacks ONLY.	PE554PT	4-Way	9628	Advance Hold Sequenced Return	Remote Motor	1 ¹ / ₈ hp*, 110/115 VAC 50/60 Hz, Single Phase	525
Double-Acting	Pump suitable to run multiple spring return tools.	PE554C	4-Way	9511†††	Advance Hold Return	Remote Motor	1 ¹ / ₈ hp*, 110/115 VAC 50/60 Hz, Single Phase	525
Double-Acting	Pump equipped with 3/4-way solenoid valve.	PE554S	3/4-Way	9592	Advance Hold Return**	Remote Motor & Valve	1 ¹ / ₈ hp*, 110/115 VAC 50/60 Hz, Single Phase	525

* Pumps available with 230 volt, 60/50 Hz motors. Specify voltage when ordering. See "Assemble to Order" pump options on pp 100-103.

** Holds with motor shut off.

***To order PE55 series pumps with CSA approval, add "-C" to the Order No.

† Valves have "Posi-Check" feature.

†† All remotes are 10 ft. long except for PE552S which is 25 ft. long.

†††Valving allows alternate and independent operation of two different spring return tools. Valve holds pressure only while valve is in "A" or "B" port position with pump motor shut off.

∞ Not to be used for lifting applications.

ELECTRIC PUMP

PE60 Series

Post Tensioning

56 cu. in./min. Two-Speed

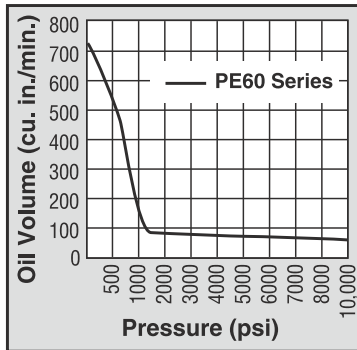

COMPACT, LIGHT WEIGHT PUMP. EXCELLENT CHOICE FOR RUGGED APPLICATIONS AND LOW VOLTAGE STARTING.

- Long, trouble free life in the most demanding work environments. For operating single- or double-acting cylinders, or stressing jacks.
- Powered by 1½ hp, 115 volt, 60/50 Hz single phase motor. Starts under load, even at the reduced voltages at construction sites.
- Optional fan-driven external oil cooler includes rollover guard.
- Insulated carrying handle.
- Integral 4" dia. fluid-filled pressure gauge with steel bezel complies with ASME B40.1 Grade A. With 0 to 10,000 psi pressure range in 100 psi increments.
- Sealed ¾ gallon (usable) reservoir. Reservoir drain port is standard.
- Standard oil level sight gauge for accurate oil level monitoring.
- External spin-on filter removes contaminants from circulating oil to maximize pump, valve and cylinder/tool life.

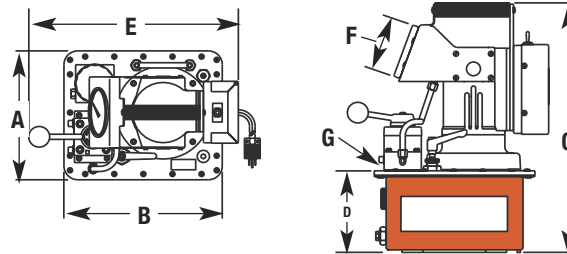

Pump No.	Max. Pressure Output (psi)	rpm	dBa at Idle and 10,000 (psi)	Amp Draw at 10,000 (psi)	Oil Del. (cu. in./min. @)				A (in.)	B (in.)	C (in.)	D (in.)	E (in.)	F (in.)	G (in.)	Prod. Wt. w/Oil (lbs.)
					100 (psi)	700 (psi)	5,000 (psi)	10,000 (psi)								
PE604T	10,000	12,000	80/85*	25	704	440	74	56	9 ⁵ / ₁₆	11 ¹ / ₂	18 ¹ / ₄	6	15	4	3/8 NPTF	50
PE604PT	10,000	12,000	80/85*	25	704	440	74	56	9 ⁵ / ₁₆	11 ¹ / ₂	18 ¹ / ₄	6	15	4	3/8 NPTF	51

NOTE: Unloading pressure is 1,000 psi.

For 220/230 volt, 50/60 Hz, single-phase models, add -220 suffix.

Consult factory for PE60 pump models with other control and valve options.



PE604T

10,000 psi

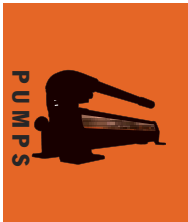

The PE60 used for pre-stressing.



For use with Cyl. Type	Description	Order No.	Valve Type	Valve No.	Valve Function	Control Switch	Motor	Reservoir Usable (cu. in.)
Single-Acting, Spring Seat, Stressing Jack or Double-Acting	1 ¹ / ₈ hp pump with ³ / ₄ gal. reservoir & valve for double-acting systems.	PE604T	4-Way 3-position	9500	Advance Hold Return	On/Off/Pulse	1 ¹ / ₈ hp, 115 VAC 60/50 Hz, Single Phase	157
Single-Acting or Double-Acting Power Seat, Stressing Jacks Only	PE604T, except has special valve for post tensioning application only.	PE604PT	4-Way 3-position	9628 Model C	Advance Hold Sequenced Return	On/Off/Pulse	1 ¹ / ₈ hp, 115 VAC 60/50 Hz, Single Phase	157
OPTIONAL								
252511: Oil cooler kit for PE604T or PE604PT, 115 VAC. Weight 5 lbs.				252512: Oil cooler kit for PE604T or PE604PT, 220 VAC. Weight 5 lbs.				

ELECTRIC PUMP

Hydraulic PQ60 Series

Up to 200 ton
60 cu. in./min.

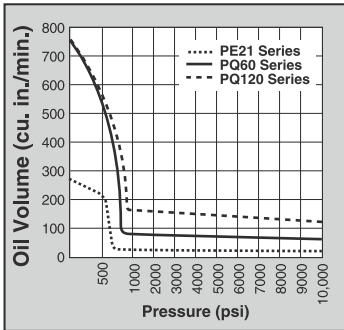

PUMP DESIGNED SPECIFICALLY FOR HEAVY DUTY, EXTENDED CYCLE OPERATION.

- For operating single- or double-acting cylinders.
- Metal shroud keeps dirt and moisture out of motor and electrical components.
- Electrical shut-down feature prevents unintentional restarting of motor following an electrical service interruption.
- Internal relief valve limits pressure to 10,000 psi. External relief valve is adjustable from 1,000 to 10,000 psi.
- Pumps operate below maximum OSHA noise limitation (74-76 dBA).
- Start and operate under full load, even with voltage reduced 10%.



PQ603

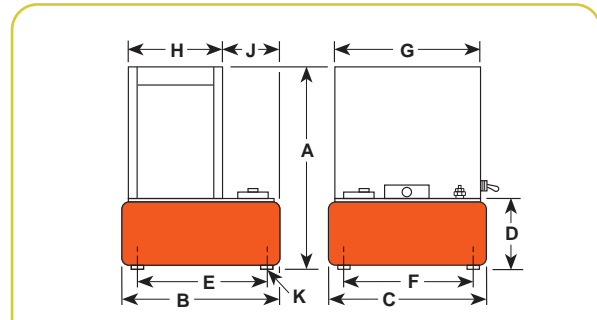

Pump No.	Max. Pressure Output (psi)	rpm	dBa at		Amp Draw at 10,000 psi (115 V.)**	Oil Del. (cu. in./min. @)				Dimensions (in.)							Prod. Wt. w/Oil (lbs.)		
			Idle	10,000		100	1,000	5,000	10,000	A	B	C	D	E	F	G		H	J
PQ60 Series	10,000	1,725	74/76*	See Chart (following page)	730	70	65	60	25 ¹ / ₈	14 ¹ / ₄	15 ¹ / ₂	7 ¹ / ₄	12 ¹ / ₈	13 ⁹ / ₁₆	14 ¹¹ / ₁₆	9 ⁹ / ₁₆	4 ¹³ / ₁₆	1/2-20 UNF	169**

* Measured at a 3 ft. distance, all sides.
 ** Total weight with oil and 3-way solenoid valve. Subtract 10 lbs. to obtain weight of pump with manual valve.
 *** For 2" dia. swivel casters, order (4) No. 10494.



PQ604



PQ604S

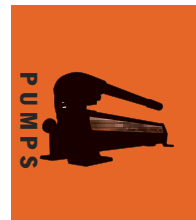

Hydraulic Machine Press Operation.

For use with Cyl. Type	Description	Order No.	Valve Type	Valve No.	Valve Function	Max. Amp Draw @ 10,000 (psi)	Motor	Reservoir Usable (cu. in.)
Single-Acting	2 hp pump with 5.7 gal. reservoir and manual valve.	PQ603	3-Way	9520*	Advance Hold Return	115V - 22 amps 230V - 11 amps	2 hp, 230 Volt 60 Hz††, Single Phase	1,250
Single-Acting	PQ603, except has solenoid operated remote valve.	PQ603S	3-Way	9599†	Advance Hold Return	115V - 22 amps 230V - 11 amps	2 hp, 230 Volt 60 Hz††, Single Phase	1,250
Double-Acting	2 hp pump with 5.7 gal. reservoir and manual valve.	PQ604	4-Way	9506*	Advance Hold Return	115V - 22 amps 230V - 11 amps	2 hp, 230 Volt 60 Hz††, Single Phase	1,250
Double-Acting	PQ604, except has solenoid operated remote valve.	PQ604S	4-Way	9512†	Advance Hold Return	115V - 22 amps 230V - 11 amps	2 hp, 230 Volt 60 Hz††, Single Phase	1,250

* Manual valve. Pump is equipped with RUN/OFF/PULSE switch for control of motor.

† Solenoid valve. Pump is equipped with a remote control switch with 10 ft. cord.

†† PQ60 series also available in 115V, 60 Hz or 220V, 50 Hz. Please specify when ordering. Example: for 60 Hz order PQ603-115; for 50 Hz order PQ603-50-220.

† Some Power Team pumps are available in special configurations not listed in this catalog. Power Team can “Assemble to Order” pumps with special seals, voltages, valves, relief valve settings, etc. For your special requirements please consult your local distributor or the Power Team factory.

ELECTRIC PUMP

PQ120 Series

Up to 400 Ton
120 cu. in./min.



- Start and operate under full load, even with voltage reduced 10%.
- Electrical shut-down feature prevents unintentional restarting of motor following an electrical service interruption.
- Internal relief valve limits pressure to 10,000 psi. External relief valve is adjustable from 1,000 to 10,000 psi.
- Pump prewired at factory with a 3hp, 460 volt, 60 Hz. 3 Phase motor. Other electrical configurations are available. See ordering information on the following page.
- 24 volt control circuits on units with remote controls for added user/operator safety.
- 3 hp (3 phase) motor with thermal overload protection. Motor starter and heater element supplied as standard equipment; no hidden charges!
- Metal shroud keeps dirt and moisture out of motor and electrical components.
- Pumps operate below maximum OSHA noise limitation.



PQ1203

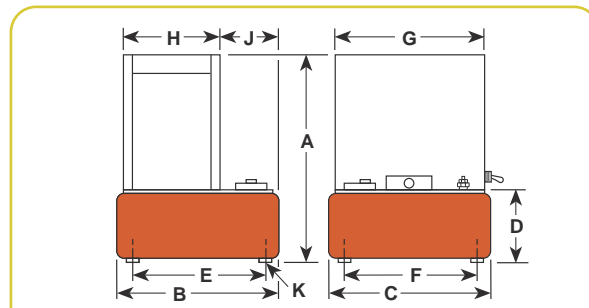
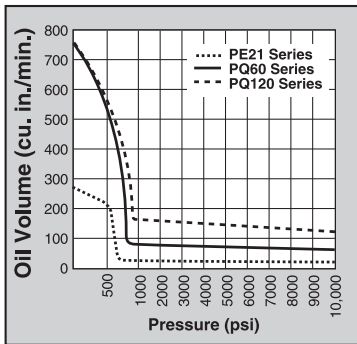

Pump No.	Max. Pressure Output (psi)	rpm	dBa at 10,000 (psi)	Amp Draw at 10,000 (psi)	Oil Del. (cu. in./min. @)				Dimensions						Prod. Wt. w/Oil (lbs.)				
					100 (psi)	1,000 (psi)	5,000 (psi)	10,000 (psi)	A (in.)	B (in.)	C (in.)	D (in.)	E (in.)	F (in.)		G (in.)	H (in.)	J (in.)	K (in.)
PQ120 Series	10,000	1,725	73/78*	See Chart On page 89	730	160	130	120	25 ¹ / ₈	14 ¹ / ₄	15 ¹ / ₂	7 ¹ / ₄	12 ¹ / ₈	13 ⁵ / ₁₆	14 ¹¹ / ₁₆	9 ⁵ / ₁₆	4 ¹³ / ₁₆	1/2-20 UNF	164**



PQ1204



PQ1204S

10,000 psi



LR19814

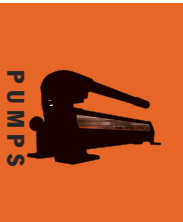

PQ- series pump used to drive piers to lift and stabilize building foundation.

For use with Cyl. Type	Description	Order No.	Valve Type	Valve No.	Valve Function	Max. Amp Draw @ 10,000 (psi)	Motor	Reservoir Usable (cu. in.)
Single-Acting	3 hp pump with 5.7 gal. reservoir and manual valve.	PQ1203	3-Way	9520*	Advance Hold Return	230V - 10.5 amps 460V - 5.3 amps	3 hp, 460 Volt 60 Hz††, 3 Phase	1,250
Single-Acting	PQ1203, except has solenoid operated remote valve.	PQ1203S	3-Way	9599†	Advance Hold Return	230V - 10.5 amps 460V - 5.3 amps	3 hp, 460 Volt 60 Hz††, 3 Phase	1,250
Double-Acting	3 hp pump with 5.7 gal. reservoir and manual valve.	PQ1204	4-Way	9506*	Advance Hold Return	230V - 10.5 amps 460V - 5.3 amps	3 hp, 460 Volt 60 Hz††, 3 Phase	1,250
Double-Acting	PQ1204, except has solenoid operated remote valve.	PQ1204S	4-Way	9512†	Advance Hold Return	230V - 10.5 amps 460V - 5.3 amps	3 hp, 460 Volt 60 Hz††, 3 Phase	1,250

* Manual valve. Pump is equipped with RUN/OFF/PULSE switch for control of motor.

† Solenoid valve. Pump is equipped with a remote control switch with 10 ft. cord.

†† PQ120 series also available in 230V 60 Hz or 220/380V 50 Hz. Please specify when ordering. Example: for 60 Hz order PQ1204S-230; for 50 Hz. order PQ1204S-50-220 or PQ1204S-50-380. PQ120 Series also available in 575V 60 Hz. Consult the factory.

‡ Some Power Team pumps are available in special configurations not listed in this catalog. Power Team can “Assemble to Order” pumps with special seals, voltages, valves, relief valve settings, etc. For your special requirements please consult your local distributor or the Power Team factory.

ELECTRIC PUMP

PE400 Series

Up to 1,000 Ton
420 cu. in./min.

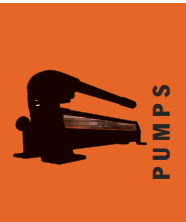

HIGH TONNAGE DOUBLE-ACTING CYLINDERS, SINGLE OR MULTIPLE CYLINDER APPLICATIONS. UP TO 1,000 TONS

- Two-speed high output pump delivers up to 5 gpm of oil.
- Low noise level of 73-80 dBA.
- Integral electrical shut-down feature prevents unintentional restarting of motor following an electrical service interruption. Over-current protection prevents damage to motor as a result of overheating.
- “Stop” and “Start” control buttons are 24 volt. PE4004 has a 4-way/3-position manual valve. The PE4004S has a 4-way/3-position solenoid valve with a 24 volt remote hand switch.
- External pressure relief valve is adjustable from 1,500 to 10,000 psi.
- Heavy duty 4" dia. casters assure easy maneuvering.
- 20 gallon (3,927 cu. in. usable) reservoir has a low oil level sight gauge.
- Powered by a dual voltage 10 hp, 3 phase, 1,725 rpm motor.
- 3 phase motor has all the electrical components necessary to operate the pump. The customer has no hidden charges when making purchase.
- Deliver 1,200 cu. in./min. of oil @ 200 psi, 420 cu. in./min. of oil @ 10,000 psi.

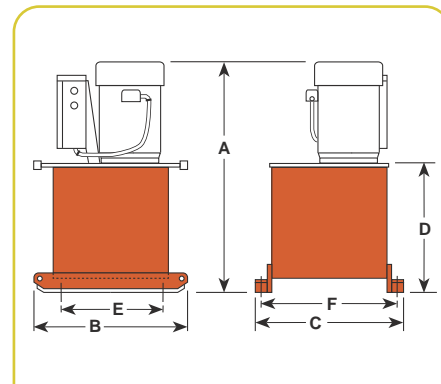
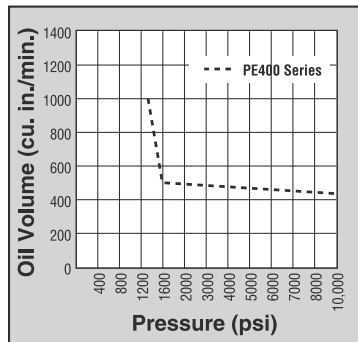

Pump No.	Max. Pressure Output (psi)	rpm	dBa at Idle and 10,000 (psi)	Amp Draw at 10,000 (psi)	Oil Del. (cu. in./min. @)				A* (in.)	B (in.)	C (in.)	D (in.)	E Caster Mfg. (in.)	F Caster Mfg. (in.)	Prod. Wt. w/Oil (lbs.)
					200 (psi)	1,200 (psi)	5,000 (psi)	10,000 (psi)							
PE4004	10,000	1,725	73/80	34 @230 V.	1,200	1,050	450	420	36 ³ / ₈	25	24	21 ¹ / ₄	15 ¹ / ₂	21 ¹ / ₂	492
PE4004S	10,000	1,725	73/80	17 @460 V.	1,200	1,050	450	420	36 ³ / ₈	25	24	21 ¹ / ₄	15 ¹ / ₂	21 ¹ / ₂	506

* Add 5" and 8 lbs. when casters are mounted. (Units are supplied with four 4" dia. swivel casters.)



PE4004S pump and RD3006 cylinder used in a special press which repairs damaged chain links for the shipping industry.



PE4004S

10,000 psi

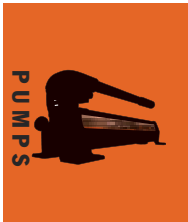

For use with Cyl. Type	Description	Order No.	Valve Type	Valve No.	Valve Function	Motor††	Reservoir Usable (cu. in.)
Double-Acting	10 hp pump with 20 gal. reservoir and manual valve.	PE4004	4-Way	9506	Advance Hold Return	10 hp, 208/230/460 volt* 60 Hz, 3 Phase	3,927†
Double-Acting	PE4004, except has solenoid operated remote valve.	PE4004S	4-Way	9512*	Advance Hold Return	10 hp, 208/230/460 volt* 60 Hz, 3 Phase	3,927†

* Factory wired for this voltage. For 230V, 60Hz order PE4004S-230.

** Solenoid valve with remote control.

† Usable oil is calculated with oil fill at recommended level at 2 1/4" below cover plate.

†† PE400 series available in 220/380V, 50Hz and 575V, 60Hz. Please specify when ordering. Example: PE4004-50-380 or PE4004-575.

NOTE: Valves for spring return cylinders are available upon request. Consult the factory.

CRIMPING PUMP

Electric PE-Nut

30 cu. in./min Two-Speed

EXTREMELY DURABLE YET LIGHTWEIGHT AND OPERATE UNDER LOW-LINE VOLTAGE CONDITIONS.

PE-NUT PUMP — 115V

- 5/8 hp universal electric motor (50/60 cycle)
- Two-stage pump for rapid ram advance
- Operational under low-line voltage conditions
- Optional operating pressures available;

- consult Power Team for details
- Designed for use with spring-returned remote tools
- High-pressure safety relief valve
- Remote hand control with 10-foot cord
- Carrying handle
- Factory filled oil reservoir
- Pressure matched quick-coupler supplied
- Optional carrying case
- Unique, intermittent duty pump,
- Piston-type high-pressure pump super-charged by a low-pressure pump.



⚠ CAUTION: DESIGNED FOR CRIMPING APPLICATIONS ONLY! This system should not be used for lifting.

Order No.	Oil Delivery per min.	Oil Reservoir	Usable Oil	Overall Width in.	Overall Length in.	Overall Depth in.	Pump Weight w/Oil lbs.
PE-NUT PE-NUTC*	(160 in ³ @ 100 psi 30 in ³ @ 10,000 psi)	93 in ³	43 in ³	6.5	14.38	8.25	28

*Includes Case

Electrical Data	
Electric Motor 5/8 hp, 10,000 rpm 115V AC, 50/60 Hz 11 amp current draw (115V @ 10,000 PSI)	Electrical Control Remote control with 10-foot cord

CRIMPING PUMP

Gas Hydraulic PG120

Crimping Pump

1303 cu. in./min Two-Speed

TWO-STAGE PUMP FOR RAPID ADVANCE GASOLINE POWER PUMPS

PG1203-CP

- 6 hp Briggs & Stratton engine
- Manual control valve
- High-pressure safety relief valve
- Protective roll cage
- For use with single acting tools

PG1203/4S-CP

- 5.5 hp Honda OHV-type engine
- Remote hand control with 10' cord
- Two-stage pump for rapid advance
- High-pressure safety relief valve
- Protective roll cage
- For use with either single or double acting tools



⚠ CAUTION: DESIGNED FOR CRIMPING APPLICATIONS ONLY! This system should not be used for lifting.

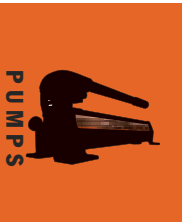

Order No.	Oil Delivery per min.	Oil Reservoir gal.	Usable Oil in.3	Overall Width in.	Overall Length in.	Overall Height in.	Pump Weight w/Oil lbs.
PG1203-CP	(480 in ³ @ 100 psi)	3	700	19.75	21.75	24.5	154
PG1203/4S-CP							

GASOLINE PUMP

PG30/55 Series

30-55 cu. in./min.

Gasoline driven



PG303

- A logical choice at work sites where electricity or compressed air are unavailable. For single- or double-acting cylinders at operating pressures to 10,000 psi.
- All gasoline engine/hydraulic pumps feature "Posi-Check" valve to guard against pressure loss when valve is shifted from "advance" to "hold".

PG303 and PG304

- Powered by a 4-cycle, 2 hp Honda engine giving it the lowest weight to horsepower ratio of all gasoline driven pumps. Has an aluminum reservoir with 375 cu. in. of usable oil.
- Has same basic pump as PE30 series electric operated pumps.
- PG30 series pumps are equipped with roll cages to protect pump from damage.
- PG30 series pumps weigh in at only 35 lbs. with oil.
- PG303 is for single-acting cylinders, has a 9520 valve with separate internal return line; allows oil from running pump to return to reservoir, independently of cylinder return oil, when valve is in "return" position.
- PG304 is for double-acting cylinders, has a 9506 4-way (tandem center) valve.



GASOLINE POWER SUPPLY IDEAL FOR REMOTE LOCATIONS. PG30 SERIES FOR TO 75 TON CYLINDERS. PG55 SERIES FOR UP TO 150 TON CYLINDERS.

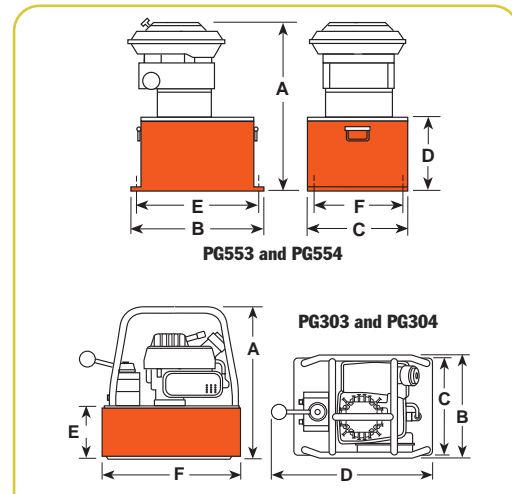
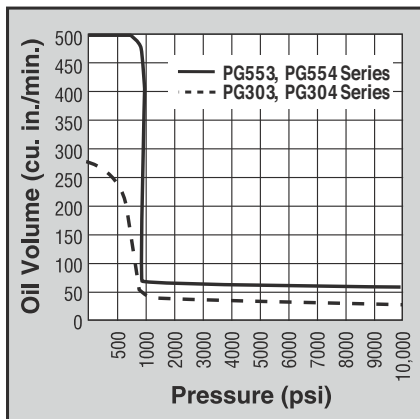

Pump No.	Max. Pressure Output (psi)	rpm	Oil Del. (cu. in./min. @)				Dimensions						Prod. Wt. w/Oil (lbs.)
			100 (psi)	1,000 (psi)	5,000 (psi)	10,000 (psi)	A (in.)	B (in.)	C (in.)	D (in.)	E (in.)	F (in.)	
PG303, PG304	10,000	8,000	275*	30	33	28	14 ⁷ / ₈	10 ³ / ₈	11 ¹ / ₂	16	5 ¹ / ₈	13 ¹ / ₂	32
PG553, PG554	10,000	3,600	480	75	70	55	22	18	12 ¹ / ₂	8 ⁵ / ₈	16 ⁵ / ₈	20 ¹ / ₄	120

* First stage oil delivery from 0-400 psi @ 230 cu. in. per minute minimum.

PG553 and PG554

- 6 hp Intek “Diamond Edge” 4-cycle, by Briggs & Stratton. 5 gallon reservoir.
- Same basic pump as PE55 series electrical Vanguard® pumps.
- PG553 has a 9520 3-way valve for single-acting cylinders.
- PG554 has a 9506 4-way valve for double-acting cylinders.

PG554

10,000 psi

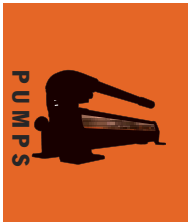

Gasoline Powered Hydraulic Pumps like this PG303 help provide hydraulic force at remote locations.



For use with Cyl. Type	Description	Order No.	Valve Type	Valve No.	Valve Function	Reservoir Usable (cu. in.)	Horsepower	Cycle
Single-Acting	2 hp pump with 2 gal. reservoir and single-acting valve.	PG303	3-Way	9520	Advance Hold Return	375	2	2
Single-Acting	6 hp pump with 5.7 gal. reservoir and single-acting valve.	PG553	3-Way	9520	Advance Hold Return	1,300**	6	4
Double-Acting	PG303, except has double-acting valve.	PG304	4-Way	9506	Advance Hold Return	375	2	2
Double-Acting	PG553, except has double-acting valve.	PG554	4-Way	9506	Advance Hold Return	1,300**	6	4

** Usable oil is calculated with oil fill at recommended level at 1/2" below cover plate

GASOLINE PUMP

PG120-PG400 Series

130-400 cu. in./min.

Max.output gas powered pumps.

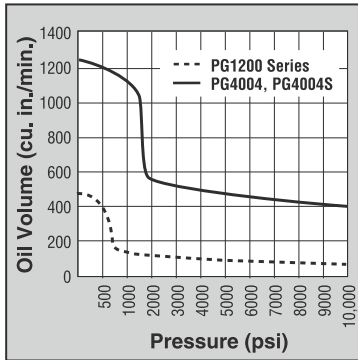

10,000 psi



PG4004S

- Two-speed high performance pumps ideal for construction, structure moving and rigging applications.
- A logical choice at work sites where electricity or compressed air are unavailable. For single- or double-acting cylinders at operating pressures to 10,000 psi.
- All gasoline engine/hydraulic pumps feature “Posi-Check®” valve to guard against pressure loss when valve is shifted from “advance” to “hold”.
- PG1200 Series pumps powered by a Honda 4-cycle, 5.5 hp engine with automatic decompression and electronic ignition. Deliver over ½ gallon (130 cu. in.) of oil per minute at 10,000 psi.
- A 5 gallon reservoir means adequate capacity for multi-cylinder applications. Dual element air cleaner protects engine from dusty environments.
- Heavy duty “roll cage” provides pick-up points for lifting. Horizontal bars on PG1203, PG1204 and PG1204S protect unit, provide hand holds for carrying.
- Rubber anti-skid insulation on bottom of reservoir resists skidding and dampens vibration. PG1200M-4 and PG1200M-4D include a pump cart with 12" wheels.
- Adjustable external pressure regulator.

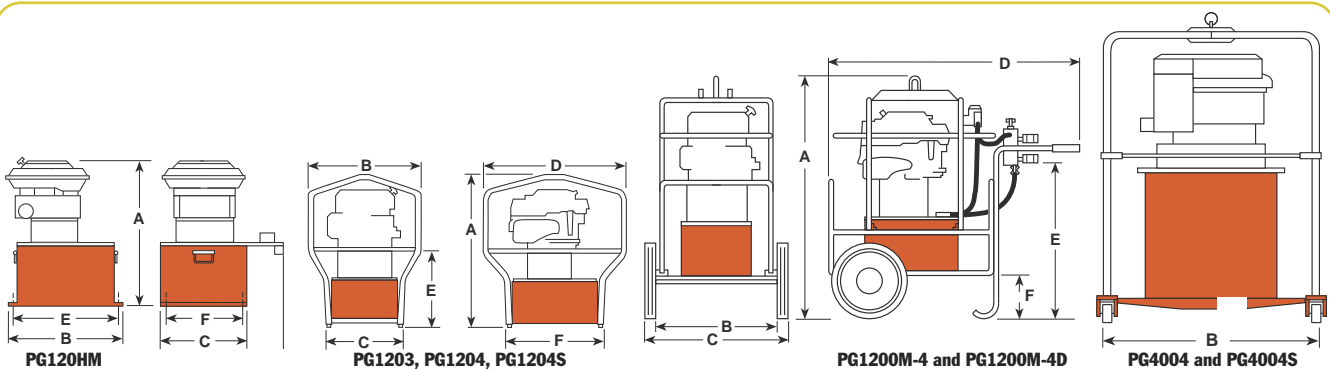

Pump No.	Max. Pressure Output (psi)	rpm	Oil Del. (cu. in./min. @)				A (in.)	B (in.)	C (in.)	D (in.)	E (in.)	F (in.)	Prod. Wt. w/Oil (lbs.)
			100 (psi)	1,000 (psi)	5,000 (psi)	10,000 (psi)							
PG120HM	10,000	3,600	480	175	150	130	23	15½	14¼	19	13 ⁵ / ₁₆	12 ¹ / ₈	150
PG1203	10,000	3,600	480	175	150	130	27 ⁷ / ₈	20¼	14¼	26¼	13½	18¼	154
PG1204	10,000	3,600	480	175	150	130	27 ⁷ / ₈	20¼	14¼	26¼	13½	18¼	154
PG1204S	10,000	3,600	480	175	150	130	27 ⁷ / ₈	20¼	14¼	26¼	13½	18¼	161
PG1200M-4	10,000	3,600	480	175	150	130	42¼	18	25	42½	26¼	7¼	260
PG1200M-4D	10,000	3,600	480	175	150	130	42¼	18	25	42½	26¼	7¼	280
PG4004	10,000	3,600	1,240	1,120	475	400	50¼	52	52	—	—	—	435
PG4004S	10,000	3,600	1,240	1,120	475	400	50¼	52	52	—	—	—	440

PG1204S



PG1200M-4D

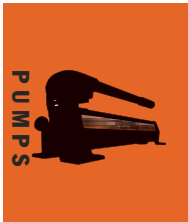

PG1200M-4

- For single-acting cylinders. Has 9520 3-way/3-position (tandem center) valve, 9596 load lowering valve and 9644 4-port manifold with individual needle valves at each port.
- Has a 9796 coupler and 9797 dust cap at each port. Valving permits precise individual control of up to four cylinders.
- A 9052 heavy duty, fluid filled pressure gauge (0-10,000 psi) is included.

PG1200M-4D

- For single- or double-acting cylinders with precise individual control of up to four cylinders possible.
- Equipped same as PG1200M-4, except has 9506 4-way/3-position

(tandem center) valve, and second 4-port manifold without needle valves mounted beneath 9644 manifold for operating double-acting cylinders.

PG400 Series Maximum output Hydraulic Power Package

- Ideal for single or multiple cylinder applications. Has a 4-cycle, 20 hp Honda engine and 20 gallon reservoir (17 gallons usable) with low oil level sight gauge.
- Steel “roll cage” protects pump, has a lifting hook; 4” dia. swivel casters provide mobility.

- Delivers 400 cu. in. of oil at maximum operating pressure.
- Has a 9506 4-way valve. On/off switch and speed control are protected by a panel. Sturdy molded case protects battery (not included).

For use with Cyl. Type	Description	Order No.	Valve Type	Valve No.	Valve Function	Usable (cu. in.)	Reservoir Horsepower	Cycle
Single-Acting	Base model 5½ hp gasoline pump with 5.7 gal. reservoir.	PG1203	3-Way	9520	Advance Hold Return	1,300	5.5	4
Single-Acting	PG1203 with cart, rollcage, load lowering valve, 4 port manifold & gauge.	PG1200M-4	3-Way Manifold	9520 9644	Advance Hold Return**	1,300	5.5	4
Single-Acting/ Double-Acting	PG1200M-4D, except without “Roll Cage” and cart. Ideal for house moving industry.	PG120HM	4-Way Manifold	9506 9642	Advance Hold Return**	1,300	5.5	4
Double-Acting	Base model 5½ hp gasoline pump, with 5.7 gal. reservoir, roll cage and double-acting valve.	PG1204	4-Way	9506	Advance Hold Return	1,300	5.5	4
Double-Acting	PG1204, except has roll cage, solenoid valve and 25 ft. cord.	PG1204S	4-Way Solenoid***	9516	Advance Hold Return	1,300	5.5	4
Double-Acting	PG1200M-4, except for double-acting systems.	PG1200M-4D	4-Way Manifold	9506 9644	Advance Hold Return**	1,300	5.5	4
Double-Acting	Base model 20 hp pump with 20 gal. reservoir.	PG4004	4-Way	9506	Advance Hold Return	3,927	20	4
Double-Acting	PG4004, except has solenoid operated remote valve.	PG4004S	4-Way Solenoid***	9516	Advance Hold Return	3,927	20	4

* Usable oil is calculated with oil fill at recommended level at 2¼" below cover plate.

** Control up to 4 cylinders independently.

*** Has 25 ft. remote control cord.

INTENSIFIER

Hydraulic

Pressure ratio 5:1

HB443



10,000 psi

CONVERTS LOW-PRESSURE PORTABLE HYDRAULIC PUMPS OR ON-BOARD HYDRAULIC SYSTEMS, INTO HIGH PRESSURE POWER SOURCES.

- Applications include utilities, railroads, construction, riggers and others.
- Operates single- or double-acting cylinders, jacks, and tools such as crimpers, spreaders, cable cutters, or tire tools. Version for use with double-acting torque wrenches available.
- May be used to operate two separate, single-acting tools (with integral valves) independently, without need for additional manifold.
- Control valve included. Other Power Team valves available as an option to suit your specific application, if needed; consult factory.
- Compact and rugged for use inside a utility vehicle aerial bucket or stowing in a vehicle.
- No reservoir level to maintain; uses low pressure system as oil supply.
- Has $\frac{3}{8}$ " NPTF ports; compatible with standard fittings for low and high pressure systems.

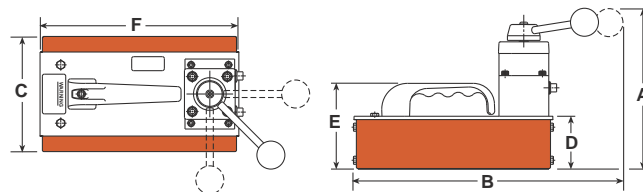

Pump No.	Output Flow @ 10,000 (psi)	A (in.)	B (in.)	C (in.)	D (in.)	E (in.)	F (in.)	Prod. Wt. (lbs.)
HB44 Series	44 cu. in./min.	8 ⁵ / ₈	14 ¹ / ₂	6 ¹ / ₈	2 ³ / ₄	4 ¹ / ₂	10 ¹ / ₂	16

For use with Cyl. Type	Description	Order No.	Valve Type	Valve No.	Output Flow Valve Function	Input Flow Range (gpm)	Input Flow Pressure (psi)	Output Flow Range (gpm)
Single-Acting	Hydraulic intensifier for single-acting systems	HB443	3-Way 3-Position	9520*	Advance Hold Return	0 -10	300 - 2,000	0 - 2.5
Single-Acting/ Double-Acting	Hydraulic intensifier for double-acting systems	HB444	4-Way 3-Position	9506*	Advance Hold Return	0 -10	300 - 2,000	0 - 2.5
Double-Acting	Hydraulic intensifier for double-acting torque wrench tools	HB445-RR	4-Way 3-Position	-	Advance Hold Return	0 -10	300 - 2,000	0 - 2.5

† For maximum efficiency, recommended input flow is 5 gpm at a maximum pressure of 2,000 psi. Higher flows and/or pressures must be compensated for at the system pump (e.g., relief valve, variable flow devices, etc.).

* "Posi-Check®" valve design, "Posi-Check®" guards against pressure loss when valve is shifted from "advance" position to "hold" position.

TORQUE WRENCH PUMPS

Hydraulic
700 Bar



CAUTION: This system should not be used for lifting applications.

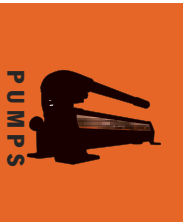

**For Torque Wrench Pumps,
see page 172-175**



ASSEMBLE TO ORDER PUMPS

Custom built hydraulic pump

CHOOSE YOUR BASIC PUMP, SELECT YOUR ACCESSORIES, AND WE WILL ASSEMBLE, TEST AND SHIP YOUR PUMP.



1
PE55A
PE55B
PE90A
PE90B



2
PE55C
PE55D
PE55F
PE90C
PE90D
PE90F



3
PE120M

10,000 psi



4
PA55A
PA90A



5
PG55A

ORDER A "CUSTOM BUILT" HYDRAULIC PUMP

"Assemble to Order" means you can choose a basic pump with gas, air or electric motor. Then select the proper valve, gauge, pressure control, motor control and reservoir. You get a two-stage pump that gives high oil volume for fast cylinder approach (and return with double-acting cylinders) in the first stage and high pressure in the second stage.

1 1½ HP UNIVERSAL MOTOR

These motors start under full load and are suitable for operation up to 5,000 or 10,000 psi. The motor is 1½ hp, 12,000 rpm, 115 or 230 volt (specify), 50/60 cycle A.C. single phase (25 amp draw at 115V.). With proper valve they can be used with single- or double-acting cylinders. Remote control available.

2 1½ HP JET MOTOR, SINGLE & THREE-PHASE

Feature low noise level, moderate speed for long service and are ideal for fixed applications. Motor is 1½ hp, 3,450 rpm, 115 or 230 volt, 50 or 60 cycle (specify), A.C. single phase with thermal overload switch. Can be used with single- or double-acting cylinders and equipped with remote control. Also available in 230/460 volt, three-phase (specify).

NOTE: These do not start under full load unless valve is in "neutral" (requires open or tandem center valve) and are not recommended for frequent starting and stopping.

3 3 HP JET MOTOR, THREE-PHASE

Gives low noise level and long life due to its moderate operating speed. Ideal for fixed installations. Consists of basic 10,000 psi pump, jet pump motor: 3 hp, 3,450 rpm, 230/460 volt, 60 or 50 cycle (specify). A.C. three-phase, with thermal overload switch. Equipped with internal and external relief valve. Will start under load.

4 3 HP AIR MOTOR

This pump is ideal for use where electricity is unavailable or cannot be used. The 5,000 or 10,000 psi pump has a 3 hp air driven motor at 3,000 rpm (optimum performance based on 80 psi air pressure and 50 cfm at the pump). You can drive single- or double-acting cylinders with the correct valve.

NOTE: 80 psi air supply required to start under full load.

5 GASOLINE ENGINE

This version is perfect when electricity and air are unavailable. It is capable of continuous operation at full pressure. Consists of basic 10,000 psi pump, 4-cycle Briggs & Stratton "Diamond Edge" gasoline engine, developing 6 hp. As with all these pumps, this unit can be valved for use with either single- or double-acting cylinders.

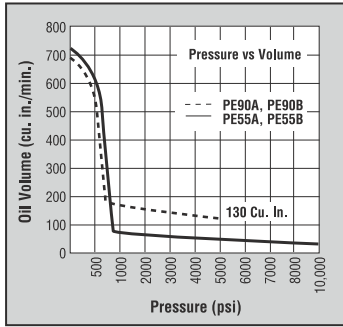

dBA @ idle and 10,000 psi – 90/95
dBA @ idle and 5,000 psi – 90/95

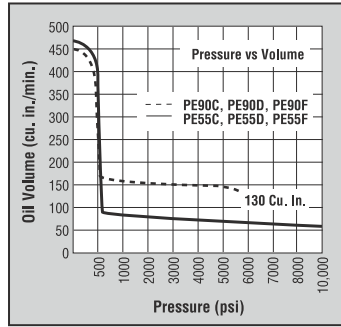

dBA @ idle and 10,000 psi – 80/85

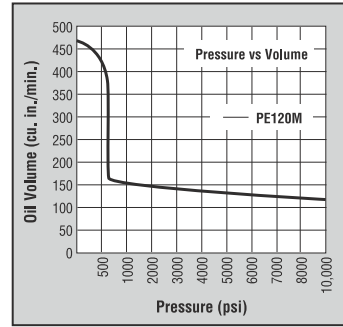

dBA @ idle and 10,000 psi – 80/85

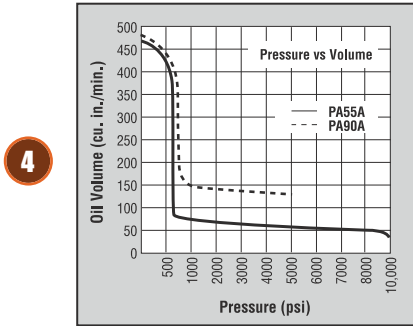

dBA @ idle and 10,000 psi – 83/88
dBA @ idle and 5,000 psi – 83/88

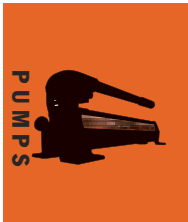
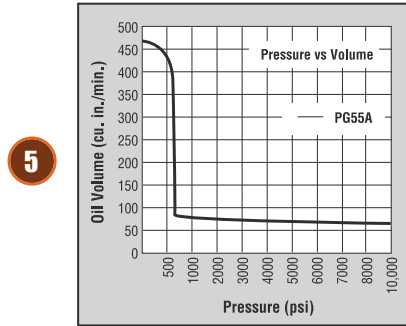

“ASSEMBLE TO ORDER” PUMP HOW TO ORDER YOUR “CUSTOM” HYDRAULIC PUMP..

You can choose from pre-engineered, off-the-shelf components to customize your pump. All the components are listed in table form, with key letters or numbers on pages 102-103. Complete instructions guide you through so you

can determine what is needed to complete a pump assembly. Shown below is an example of a custom-built pump.

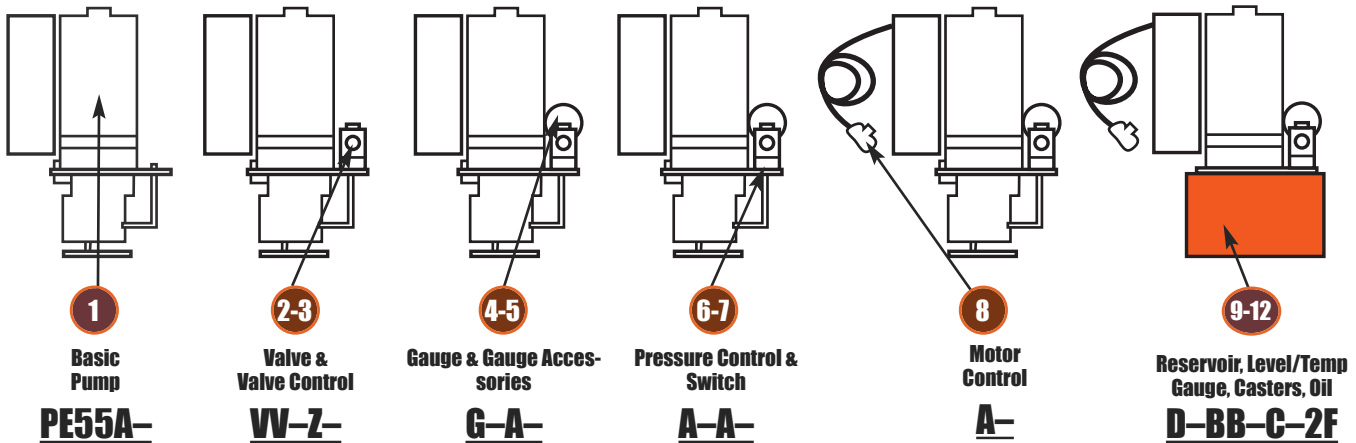

Pump No. PE55A-VV-Z-G-A-A-A-D-BB-C-2F is a 10,000 psi two-speed pump with a 115 volt, 50-60Hz, single phase, 1½ hp, 12,000 rpm motor; a 9512 4-way solenoid valve with a 202778 remote hand control, a 9041 pressure

gauge, no gauge accessories, standard pressure control, standard On-Off-Pulse motor control, 400630R9 2-gallon reservoir, a 350431 oil level/temperature gauge, 10494 casters, and 2 gallons of standard hydraulic oil.

See next two pages for pump components

ASSEMBLE TO ORDER PUMPS

Component Specification Chart

TO BUILD YOUR PUMP, FILL IN KEY LETTERS FROM CHARTS

1 Basic Pump	2 Select Valve	3 Select Valve Control	4 Select Gauge	5 Select Gauge Accessories	6 Pressure Control
7 Pressure Switch	8 Motor Control	9 Reservoir	10 Level/Temp Gauge	11 Choose Casters	12 Select Oil

Use the charts numbered from 1-12 below to select the pump, valve, gauge and other accessories to suit your needs. For the pump, fill in the basic number plus key letter in block 1 above and the key letter only in the blocks 2-12 above for any of the other items. Refer to the appropriate pages in this catalog for more specific information on the products you need.

1 BASIC PUMP (See pages 82-94)

BASIC PUMP NUMBERS						SPECIFICATIONS		
PE55 (10,000 psi)	PE90 (5,000 psi)	PE120 (10,000 psi)	PA55 (10,000 psi)	PA90 (5,000 psi)	PG55 (10,000 psi)	NOTE: Customer must specify voltage required.		
						Power Source	rpm	hp
A or AC*	A or AC*					115V-60 Hz, 1Ø	12,000	1½
						110V-50 Hz, 1Ø	12,000	1½
B or BC*	B or BC*					230V-60 Hz, 1Ø	12,000	1½
						220V-50 Hz, 1Ø	12,000	1½
† C or CC*	† C or CC*					115V-60 Hz, 1Ø	3,450	1½
† C50	† C50					110V-50 Hz, 1Ø	2,850	1½
† D or DC*	† D or DC*					230V-60 Hz, 1Ø	3,450	1½
† D50	† D50					220V-50 Hz, 1Ø	2,850	1½
† F60 **	† F60**					208, 230/460V-60 Hz, 3Ø	3,450	1½
† F50 **	† F50**					220/380V-50 Hz, 3Ø	2,850	1½
		M60 **				208, 230/460V-60 Hz, 3Ø	3,450	3
		M50 **				220/380V-50 Hz, 3Ø	2,850	3
			A	A		Air Motor	3,000	3
					A	Gas Engine	3,600	6

*Suffixes AC, BC, CC & DC indicate pumps for Canadian orders only.

NOTE: All electric units have 24 volt secondary circuit.

**Specify voltage required.

† These pumps do not start under full load unless valve is in "neutral" position (requires open or tandem center valve) and are not recommended for frequent starting and stopping.

2 VALVE (See pages 122-129)

Manifold/Manual/Air Operated Directional Valves		Function	Manifold/Manual/Air Operated Directional Valves		Function
AB	9628 manual, tandem center	4-way, 3 pos. valves	O	9609 manual, pressure compensated flow control	3-way, 4 pos.
AC	9632 manual "twin" tandem and open center		R	9506 manual, tandem center "Posi-Check"	
A	None	—	RR	9511 manual, open center	4-way, 3 pos. valves
B	9626 manifold	Manifold	S	9500 manual, tandem center	
C	9584 manual	3-way,	T	9507 manual, closed center "Posi-Check"	
D	9582 manual	2 pos. valves	U	9501 manual, closed center	
E	9610 automatic, pilot operated	valves	Solenoid Operated Directional Valves		Function
G	9504 manual	3/4-way,	FF	9569 solenoid operated - 24 volt	3-way, 2 pos.
JJ	9594 air operated	2 pos. valves	HH	9572 solenoid operated - 24 volt	3/4-way, 2 pos.
L	9502 manual, closed center "non-interflow"	3-way,	PP	9599 solenoid operated - 24 volt	3-way, 3 pos.
M	9520 manual, tandem center "Posi-Check"	3 pos. valves	VV	9512 solenoid operated - 24 volt	4-way,
N	9576 manual, metering tandem center	valves	WW	9615 solenoid operated - 24 volt	3 pos. valves

3 VALVE CONTROL (See page 130)

Valve Remote Control		Use with Valve	Valve Remote Control		Use with Valve
A	None	—	Z	202778 remote hand control, 10 ft.	9512 or 9615
X	304718 remote hand control, 10 ft.	9572	ZF	309653 remote foot control, 10 ft.	9512, 9615,
XF	309652 remote foot control, 10 ft.	9572			9569 or 9599
Y	202777 remote hand control, 10 ft.	9569 or 9599	ZZ	209593 remote hand control, 12 ft.	9594

4 GAUGE (See page 110-111)

Pressure Gauges	
A	None
B	Other – Specify
G	9041 0-10,000 psi – 0-689 Bar (2½" dia.)
H	9040 0-10,000 psi – 0-689 Bar (Liquid) (2½" dia.)
J	9051 0-10,000 psi – 0-689 Bar (4" dia.)
M	9052 0-10,000 psi – 0-689 Bar (Liquid) (4" dia.)

6 PRESSURE CONTROL (See page 119)

Pressure Controls	
A	With standard external pressure regulator
C	Other – specify
D	350199 premium external pressure regulator. See Power Team Catalog product No. 9633 for details.

NOTE: Pressure controls are factory pre-set at 10,000 psi unless otherwise specified.

8 MOTOR CONTROL (See page 130)

Electric Motor Controls	
A	Standard On/Off/Pulse control (does not include remote switch) for A, B, C, D, F and M electric pumps. Also used for remote controlled solenoid valves.
B	None
C	25017 remote motor hand switch, 10 ft.
D	203225 remote motor hand switch, 10 ft. (heavy duty)
E	10461 remote motor foot switch, 10 ft.
Air Motor Controls	
AA	Other
B	None
P	27876 hand motor control (for PA55 & PA90 series)
Q	27877 foot motor control (for PA55 & PA90 series)

10 OIL LEVEL/TEMP. GAUGE (SEE PAGE 132)

Oil Level/Temperature Gauge	
A	None
BB	350431 oil level/temperature gauge

11 CASTERS (See page 110)

Casters	
A	None
C	10494 caster for use with 400630R9 reservoir (Specify quantity of four)

5 GAUGE ACCESSORY (See page 53)

Gauge Accessories	
A	None
N	9049 pulsation dampener – All dry gauges

7 PRESSURE SWITCH (See page 131)

Pressure Switch	
A	None
B	9625 electric pressure switch (500-10,000 psi) NOTE: Pressure switch is factory pre-set at 10,000 psi unless otherwise specified.
C	9641 pilot operated air control valve – N.C.
D	9643 pilot operated air control valve – N.O.

9 RESERVOIR (See page 133)

Reservoirs	Capacity	
A	None	
B	Other – Specify	
D	400630R9 – PE55, PE90, PE120, PA55 and PA90 series	2½ gal.
E	61165† – PE55, PE90, PE120, PA55 and PA90 series (Oil temperatures in excess of 150° F. may cause permanent failure of the thermoplastic reservoir)	2 gal.
F	RP22‡ – PE55, PE90, PE120, PA55 and PA90 series	2½ gal.
H	617990R9 Same as D except with drain port	2½ gal.
J	RP50 – PE55, PE90, PE120, PA55 and PA90 series	5 gal.
K	401370R9 – PG55 series	5 gal.
P	209124 – PE55, PE90, PE120, PA55 and PA90 series	7 gal.
V	RP100 – PE55, PE90, PE120, PA55 and PA90 series	10 gal.
W	RP101 – PG55 series	10 gal.

NOTE: Includes cover adapter and misc. accessories when applicable.

†High density polyethylene.

‡Aluminum.

12 OIL (See page 112)

Oil	
E	Ship pump without oil
F	9637 1 gal. standard hydraulic oil
G	9638 2½ gal. standard hydraulic oil
Q	9639 1 gal. Flame-Out hydraulic oil
R	9640 2½ gal. Flame-Out hydraulic oil
U	9645 1 gal. biodegradable hydraulic oil
V	9646 2½ gal. biodegradable hydraulic oil

NOTE: Select type of hydraulic oil and specify quantity.

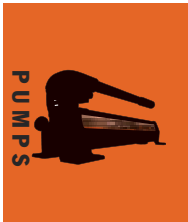

HYDRAULIC ACCESSORIES



ACCESSORIES

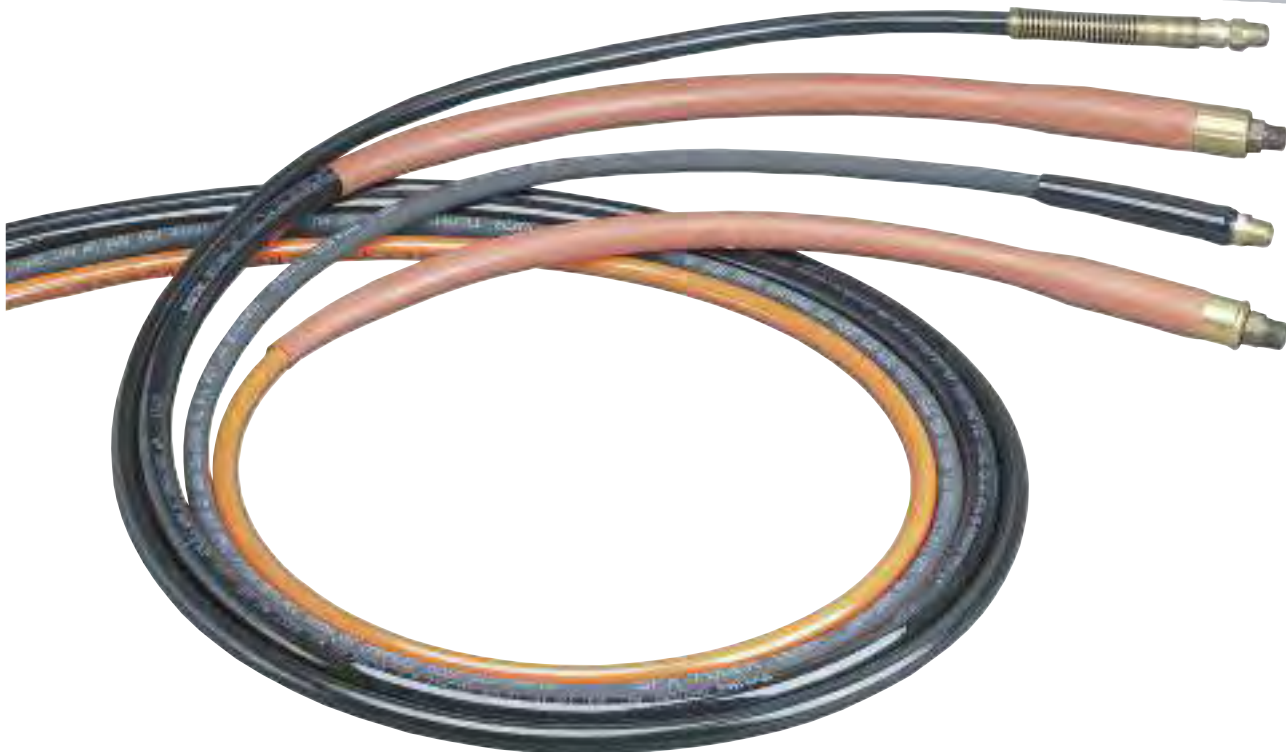



Page
HOSES...106

Rubber
Urethane
Non-Conducting

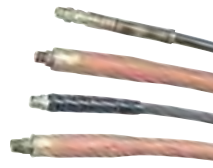

Page
COUPLERS...108

Quick Connect
Flush Face



Page
GAUGES...110-111

Heavy Duty Hydraulic Pressure Gauges
Digital and Analog



Page
FLUIDS...112

Standard Oil Quart, Gallon,
2 1/2 Gallon, 55 Gallon
Flame Out Gallon, 2 1/2,Gallon
Bio Degradable Gallon, 2 1/2,Gallon
Low Temperature Gallon



Page
MANIFOLDS...113

Standard Blocks
Blocks with Valves



Page
10,000 PSI FITTINGS...114

Connectors
Couplings
Crosses
Elbows
Tees
Swivels
Special Adapters



Page
VALVES...115-129

In-Line
Remote



Page
**PUMP ACCESSORIES
...130-133**

Motor Controls
Oil Cooler Kits
Carts/Roll Cages



ACCESSORIES



HOSES

Polyurethane Rubber Non-Conductive

- All have plastic hose guards except for the 1/4" I.D. polyurethane hoses which have spring guards.
- 3/8" NPTF fittings on both ends.
- Operating pressure is 10,000 psi. All comply with MHI standard IJ100.

Non-conductive hose

For applications requiring electrical isolation by the hose, non-conductive hose has a leakage factor of less than 50 microamperes, considered a safe level of conductivity by SAE standards. The covering is polyurethane and colored orange for easy identification as non-conductive hose. The covering is not perforated, preventing moisture from entering the hose and affecting its overall conductivity. All non-conductive hoses have a minimum burst pressure of 40,000 psi.

Rubber hose

2-ply rated hose reinforced with two braids of high tensile steel wire. The rubber covering is oil and weather resistant. These hoses are MSHA approved.

Polyurethane hose

Made up of nylon core tube with polyester fiber reinforcement which will withstand the minimum SAE bend radius without shortening service life. These hoses last up to seven times longer than rubber hose, and are suitable for continuous service at temperatures from -40° to 150° F.

Hydraulic hose assembly

No. 9764 – Hose assembly consisting of 9767 (6' hose), 1/4" I.D. polyurethane with 9798 hose half coupler and 9800 dust cap assembled.

No. 9754 – Hose assembly consisting of 9756 (6' hose), 1/4" I.D. rubber with 9798 hose half coupler and 9800 dust cap assembled.

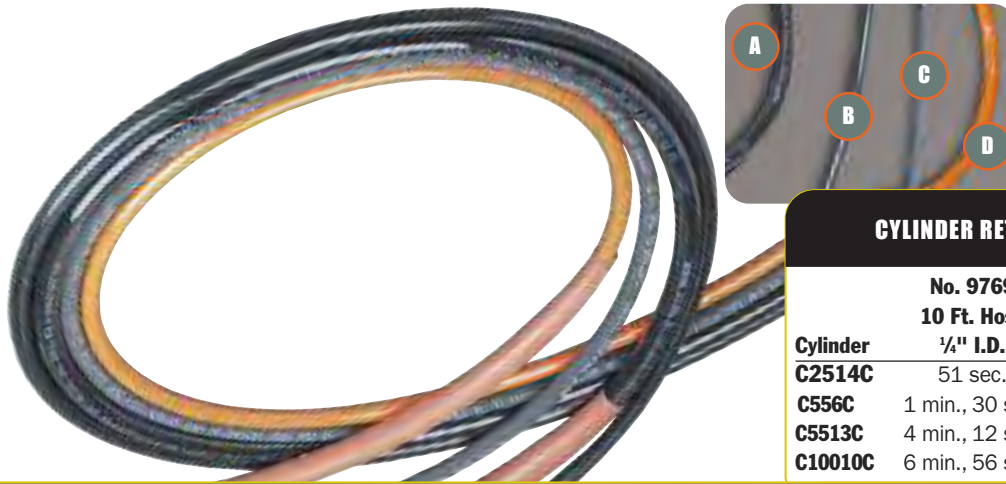

A = 3/8" I.D. Polyurethane
B = 1/4" I.D. Polyurethane
C = 1/4" & 3/8 I.D. Rubber
D = 1/4" I.D. Non-Conductive

CYLINDER RETURN TIME

	No. 9769 10 Ft. Hose 1/4" I.D.	No. 9781 10 Ft. Hose 3/8" I.D.
Cylinder		
C2514C	51 sec.	14 sec.
C556C	1 min., 30 sec.	24 sec.
C5513C	4 min., 12 sec.	59 sec.
C10010C	6 min., 56 sec.	1 min., 3 sec.

The figures show the relative effect two styles of hose can have on return time. Actual times may vary.

ORDERING INFORMATION

Hose Type	Hose I.D.	Hose Length	Burst Rating	Order No.	Hose Type	Hose I.D.	Hose Length	Burst Rating	Order No.
Polyurethane	1/4"	2 ft.	20,000 psi	9765	Rubber, Wire-braid	1/4"	8 ft.	20,000 psi	9757
Polyurethane	1/4"	3 ft.	20,000 psi	9766	Rubber, Wire-braid	1/4"	10 ft.	20,000 psi	9758
Polyurethane	1/4"	6 ft.	20,000 psi	9767	Rubber, Wire-braid	1/4"	12 ft.	20,000 psi	9759
Polyurethane	1/4"	6 ft.	20,000 psi	9764*	Rubber, Wire-braid	1/4"	20 ft.	20,000 psi	9760
Polyurethane	1/4"	8 ft.	20,000 psi	9768	Rubber, Wire-braid	1/4"	30 ft.	20,000 psi	9761
Polyurethane	1/4"	10 ft.	20,000 psi	9769	Rubber, Wire-braid	1/4"	50 ft.	20,000 psi	9762
Polyurethane	1/4"	12 ft.	20,000 psi	9770	Rubber, Wire-braid	3/8" High Flow	3 ft.	20,000 psi	9733
Polyurethane	1/4"	20 ft.	20,000 psi	9771	Rubber, Wire-braid	3/8" High Flow	6 ft.	20,000 psi	9776
Polyurethane	1/4"	50 ft.	20,000 psi	9772	Rubber, Wire-braid	3/8" High Flow	10 ft.	20,000 psi	9777
Polyurethane	1/4"	75 ft.	20,000 psi	9750	Rubber, Wire-braid	3/8" High Flow	15 ft.	20,000 psi	9734
Polyurethane	1/4"	100 ft.	20,000 psi	9751	Rubber, Wire-braid	3/8" High Flow	20 ft.	20,000 psi	9778
Polyurethane	3/8" High Flow	6 ft.	30,000 psi	9780	Rubber, Wire-braid	3/8" High Flow	30 ft.	20,000 psi	9735
Polyurethane	3/8" High Flow	10 ft.	30,000 psi	9781	Rubber, Wire-braid	3/8" High Flow	40 ft.	20,000 psi	9736
Polyurethane	3/8" High Flow	20 ft.	30,000 psi	9782	Rubber, Wire-braid	3/8" High Flow	50 ft.	20,000 psi	9779
Polyurethane	3/8" High Flow	50 ft.	30,000 psi	9783	Non-Conductive	1/4"	6 ft.	40,000 psi	9773
Rubber, Wire-braid	1/4"	3 ft.	20,000 psi	9755	Non-Conductive	1/4"	10 ft.	40,000 psi	9774
Rubber, Wire-braid	1/4"	6 ft.	20,000 psi	9756	Non-Conductive	1/4"	20 ft.	40,000 psi	9775
Rubber, Wire-braid	1/4"	6 ft.	20,000 psi	9754*					

For torque wrench tools refer to page 166-169

NOTE: Polyurethane hoses not recommended for use where heat or weld splatter conditions exist.

*Furnished with 9798 hose half coupler and 9800 dust cap.



HOSE

Non-Conductive

1/4 in I. D.
10,000 psi

NON-CONDUCTIVE HOSES

- For applications requiring electrical isolation.
- 3/8" NPTF fittings on both ends
- Leakage factor of less than 50 microampere.
- Orange polyurethane for easy identification.
- Covering is not perforated, preventing moisture from entering the hose and affecting its overall conductivity.
- Hoses feature a minimum 40,000 psi burst pressure.



TWH

HOSES – DUAL LINE

TWH15	15', 1/4" ID non-conductive
TWH20	20', 1/4" ID non-conductive
TWH50	50', 1/4" ID non-conductive



ACCESSORIES



Hose No.	Couplers/ Fitting	I. D. in.	Length ft.
9773	1/4" fitting	1/4	6
9774	1/4" fitting	1/4	10
2000351	1/4" fitting	1/4	15
2000350	1/4" fitting	1/4	25
3-3944*	Male/Male Couplers	1/4	6
3-3945*	Male/Male Couplers	1/4	10
3-3946*	Male/Male Couplers	1/4	15
3-3947*	Male/Male Couplers	1/4	25
3-3956*	Male/Female Couplers	1/4	6
3-3957*	Male/Female Couplers	1/4	10
3-3958*	Male/Female Couplers	1/4	15
3-3959*	Male/Female Couplers	1/4	25

* Hoses are prefilled with hydraulic fluid

COUPLERS

Standard &
Flush-Face



9795 Cylinder and
Hose Couplers



9796



9798



9794 No-Spill
Hose Couplers



9792

9793



9797

9799



9800



ACCESSORIES

CYLINDER AND HOSE COUPLERS

Designed for use up to 10,000 psi with hydraulic jacks, cylinders, etc.

They are the threaded union type for interchanging cylinders in seconds. Each half is valved with a precision ball for a tight shutoff when disconnected. These couplers also permit the separation of cylinders or hose from pump when at 0 psi with minimal oil loss.

No. 9795 – Complete quick coupler, $\frac{3}{8}$ " NPTF. (Includes two 9800 dust caps.)

No. 9798 – Male (hose) half coupler (less hose half dust cap), $\frac{3}{8}$ " NPTF.

No. 9796 – Female (cylinder) half coupler with No. 9800 dust cap, $\frac{3}{8}$ " NPTF.

No. 9796-V – Same as 9796, but with Viton seals.

No. 9796-E – Same as 9796, but with EPR seals.

No. 9799 – Optional metal dust cap (hose half).

No. 9797 – Optional metal dust cap (cylinder half).

NO-SPILL, PUSH-TO-CONNECT HYDRAULIC HOSE COUPLERS

High flow, no-spill, push-to-connect couplers with locking collar and flush face designed for high pressure applications. The flush-face concept makes it easy to clean both coupler ends before connecting. Our unique push-to-connect, "dry-break" design eliminates oil spillage. The locking collar makes accidental disconnects a thing of the past. For 10,000 psi operation. Designed to permit high oil flow.

No. 9792 – Female (cylinder) half quick coupler only. Wt., 0.3 lb.

No. 9793 – Male (hose) half quick coupler only. Wt., 0.3 lb.

No. 9794 – Complete quick coupler (male and female). Dust caps not included. Wt., 0.5 lb.

HYDRAULIC COUPLER DUST CAP

Dust cap fits either male or female half couplers.

No. 9800 – Dust cap. For male or female $\frac{3}{8}$ " NPTF half couplers. Wt., 0.3 lb.

HAND PUMP

System with Connections

Hand pump system hook-up
(T-adapter necessary for P12, P19, P23, P59 & P59F pumps. All other hand pumps have a gauge mounting port.)

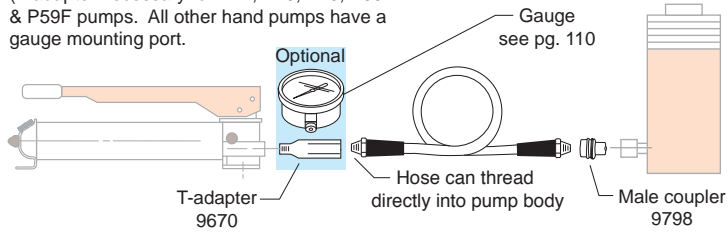

Single-acting air pump system hook-up

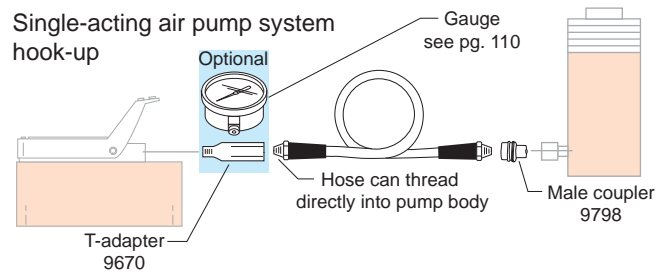

Air, Electric & Gas Pumps with valve system hook-up

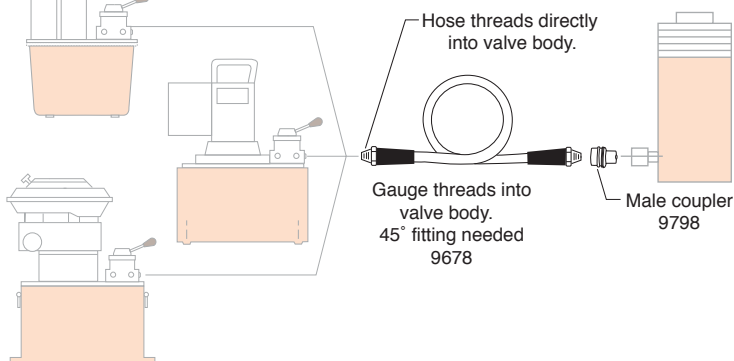

ACCESSORIES



GAUGES

Analog & Digital

ASME B40.1
GRADE B



Typical Mounting Situations

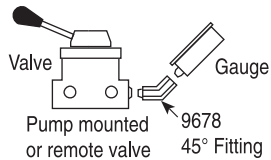
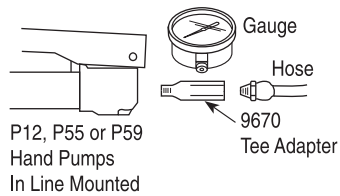

ACCESSORIES

Heavy-duty Hydraulic Pressure Gauges

- Gauges feature an easily readable and highly visible, red day-glo needle.
- High strength steel bourdon tube ensures high cycle life.
- Stainless steel cases and lens locking rings.
- 4" and 6" dry gauges can be filled with silicone (Kit #9046).
- Have ¼" NPT connections.
- Calibratable gauge

Digital Pressure Gauges

- Accurate to within 1%.
- Larger display characters than ordinary digital gauges.
- Long-life pressure transducer.
- ¼" NPTF male threads for the pressure connection.
- 6-foot signal input cable connects to back of display unit.

FEATURES

- Pressure values are displayed on large red LEDs in 10 psi or bar increments.
- "Peak" hold feature with reset toggle switch and "Peak On" indicator; Hi/Low set point feature with relay outputs for Hi/Low alarms and/or control signals.

- A slow flashing display indicates pressure below the low limit; fast blinking display alerts if limit is exceeded.
- High and low limit relays are rated to 5 amps at 115 volts.
- Operating temperature of 0-140°F for the electronic display and -20 to 180°F for the transducer. Gauge housings are extruded aluminum ⅛ DIN enclosures (NEMA 1 rating).
- When power cable is connected to gauge, display will scroll all characters, performing a self-diagnostic routine.

Digital Pressure Gauge

No. DG100 – Digital pressure gauge, pressure range 0-10,000 psi. Note: Serviced only at factory. Wt., 2.3 lbs.

No. DG100B – Digital pressure gauge, pressure range 0-700 bar. Note: Serviced only at factory. Wt., 2.3 lbs.

Digital Pressure Gauge Accessories

No. 420778 – Gauge stand for DG100. Has angled base mounting to hold gauge at a convenient viewing angle. Wt., 1.2 lbs.

No. 37045 – Auxiliary power cord for use with any 12 or 24V battery. Wt., 0.2 lb. Caution: For use on negative ground systems only.

Standard Pressure Gauge Accessories

No. 9046 – Silicone fill kit. 7.5 fl. oz. Requires one bottle to fill 4" gauge; four bottles to fill 6" gauge.

No. 9049 – High performance pulsation dampener. 1/4" NPTF male x 1/4" NPTF female.



STANDARD PRESSURE GAUGE ORDERING INFORMATION

Face Dia.	psi/Bar	Tons	Major Graduations	Minor Graduations	Silicone Filled	Use With Cylinder Series	Gauge No.
2 1/2"	0-10,000/0-690	–	2500 psi, 100 Bar	500 psi, 20 Bar	No	All	9041
2 1/2"	0-10,000/0-690	–	2500 psi, 100 Bar	500 psi, 20 Bar	Yes	All	9040
4"	0-10,000/0-690	–	1000 psi, 100 Bar	200 psi, 10 Bar	No*	All	9051
4"	0-10,000/0-690	–	1000 psi, 100 Bar	200 psi, 10 Bar	Yes	All	9052
4"	0-10,000/0-690	0-17.5, 0-30 and 0-50	2000 psi, 5 Ton	200 psi, .5 Ton on 30, 50 Ton Scales; .2 Ton on 17.5 Ton Scale	No*	RT172, RT302, RT503	9059
4"	0-10,000/0-690	0-5	2000 psi, 1 Ton	200 psi, .1 Ton	No	C & RLS	9053
4"	0-10,000/0-690	0-10	2000 psi, 1 Ton	200 psi, .1 Ton	No*	C, RD, RH, RLS & RSS	9055
4"	0-10,000/0-690	0-25	2000 psi, 5 Ton	200 psi, .5 Ton	No*	C & RD	9063
4"	0-10,000/0-690	0-30	2000 psi, 5 Ton	200 psi, .5 Ton	No*	RH†, RLS & RSS	9065
4"	0-10,000/0-690	0-50	2000 psi, 5 Ton	200 psi, .5 Ton	No*	RH†, RLS & RSS	9067
4"	0-10,000/0-690	0-55	2000 psi, 5 Ton	200 psi, .5 Ton	No*	C, R, RA & RD	9069
4"	0-10,000/0-690	0-60	2000 psi, 5 Ton	200 psi, 1 Ton	No*	RH	9071
4"	0-10,000/0-690	0-100	2000 psi, 10 Ton	200 psi, 1 Ton	No*	C, R, RA, RD, RH, RLS†, RSS† & RT1004†	9075
4"	0-10,000/0-690	0-150	2000 psi, Initial 10 Then 20 Ton	200 psi, 2 Ton	No*	C, R, RD & RLS	9077
4"	0-10,000/0-690	0-200	2000 psi, 20 Ton 10 Then 20 Ton	200 psi, 2 Ton	No*	R, RD & RH†	9079
6"	0-10,000/0-690		1000 psi, 100 Bar	100 psi, 10 Bar	No*	All	9089

* Shipped “dry.” User can convert to “wet” using liquid silicone No. 9046.

† The tonnage scale on the gauge may vary slightly among different series cylinders due to different effective area.

HYDRAULIC FLUIDS

Standard, Flame Out® ,
Biodegradable and Low Temp.



Oil Description	Qty.	Order No.
Standard Oil	1 qt. (57 cu. in.)	9636
Standard Oil	1 gal. (231 cu. in.)	9637
Standard Oil	2½ gal. (577 cu. in.)	9638
Standard Oil	55 gal.	9616
Flame-Out*	1 gal. (231 cu. in.)	9639
Flame-Out*	2½ gal. (577 cu. in.)	9640
Biodegradable	1 gal. (231 cu. in.)	9645
Biodegradable	2½ gal. (577 cu. in.)	9646
Low Temp.	1 gal. (231 cu. in.)	9647



Description	Grade (ASTM)	Specific Gravity		Flash Point	Fire Point	Pour Point	Viscosity		Foam Test (ASTM)
		@ 60°F (16°C)	Color (ASTM)				SUS @ 100°F (38°C)	SUS @ 210°F (99°C)	
Standard Oil	215	.88	2.0	400°F (204°C)	430°F (221°C)	-30°F (-34°C)	215	48	100 min. Pass
Flame-Out*	220	.91	Light Amber	500°F (260°C)	550°F (288°C)	-15°F (-26°C)	220	55	140 min. Pass
Biodegradable	—	.92	2.0	432°F (224°C)	NA*	-22°F (-30°C)	183	53	213 min. Pass
Low Temp.	—	.87	6.5 (Red)	356°F (180°C)	399°F (204°C)	-48°F (-45°C)	183	52	190 min. Pass

Standard Hydraulic Oil

- For dependable performance of all your hydraulic pumps and cylinders.
- Contains foam suppressant additives and has a high viscosity index.

Flame-Out® 220 fire resistant hydraulic fluid*

- Contains anti-rust, anti-foam and anti-sludge additives.
- Provides fire resistant protection.
(Note: Will burn if heat source is extreme enough. Will not, however, propagate the flame and is self-extinguishing when there is no ignition source.)
- Provides maximum lubrication and heat transfer.
- Offers a wider operating temperature range.
- No need to change seals in your Power Team equipment. Just drain the standard oil and replace it with Flame-Out 220.

Biodegradable Hydraulic Fluid

- Biodegradable, non-toxic fluid withstands moderate to severe operating conditions; provides excellent protection against rust.
- Offers superior anti-wear properties, has excellent multi-metal compatibility. Developed to meet stringent performance requirements and satisfy growing environmental needs for hydraulic fluids which are readily biodegradable and non-toxic. Can be used with all Power Team pumps, cylinders, valves and other accessories using standard seals. Depending on the contamination or degradation levels which might be present in used fluid, small amounts of this substance, if spilled, will not affect ground water or the environment. Acceptable methods of disposal include use as a fuel supplement. Since this fluid

will not typically be hazardous waste, additional disposal options may be available, including land farming or processing through sewage treatment facilities, if necessary approvals are obtained from appropriate regulatory authorities. This fluid has been tested against EPA 560/6-82-003 and OECD 301 for biodegradability, and toxicity has been tested against EPA 560/6-82-002 and OECD 203: 1-12. Not recommended for operation in temperatures below 20°F (-7°C) or above 160°F (71°C). Recommended storage temperatures not below -10°F (-23°C) or above 170°F (77°C). For additional technical information or to order a **MATERIAL SAFETY DATA SHEET** call **1-800-477-8326** or go to **www.powerteam.com**.
Low-Temperature Oil
Provides smooth, reliable operation in the coldest climate conditions.

MANIFOLDS

Remote and Pump-Mounted

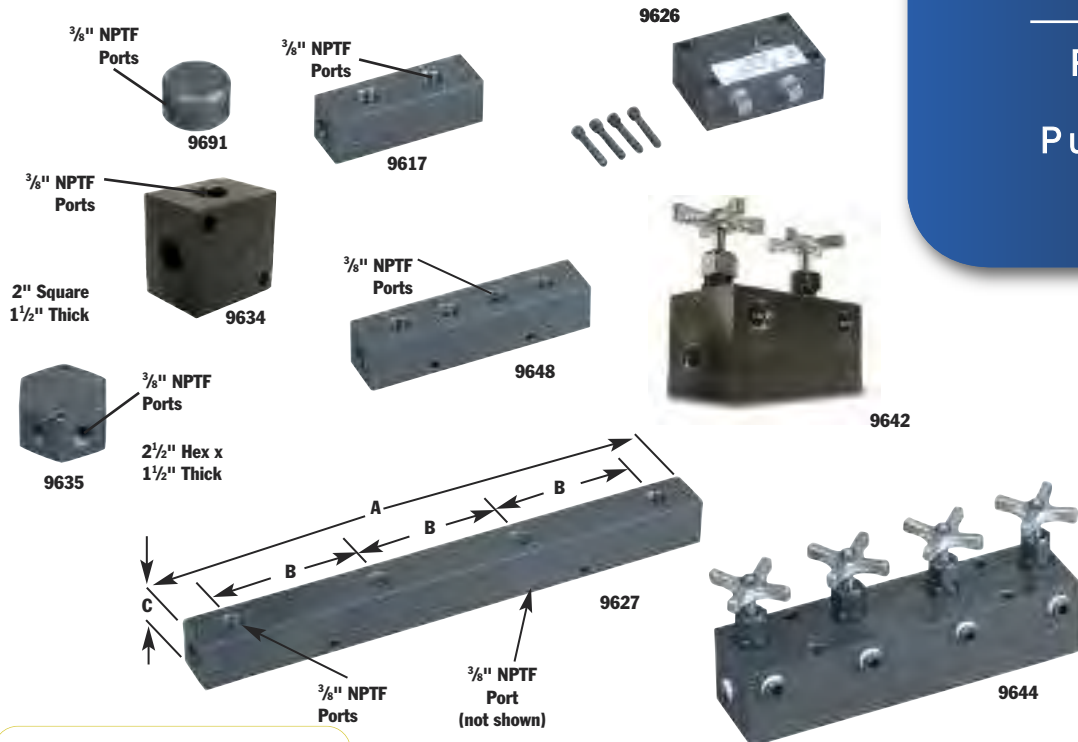

Manifold No.	A (In.)	B (In.)	C (In.)
9627	16	4 1/2	1 1/2
9648	7	1 1/2	1 1/2

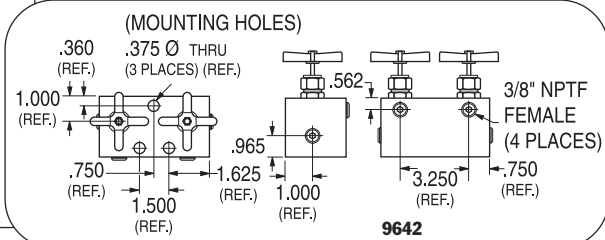
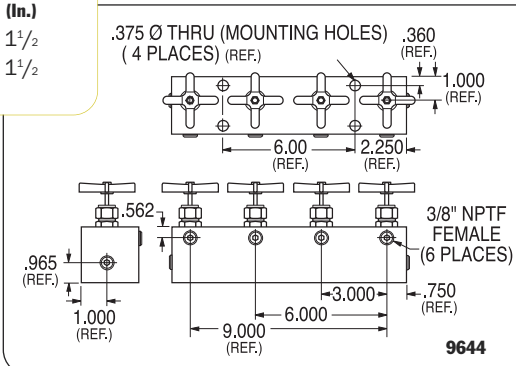

ACCESSORIES

No. 9691 – “Y” Manifold

Extremely useful when connecting two hydraulic cylinders to a single line. Has three 3/8" NPTF ports. Wt. 1 lb.

No. 9634 – Manifold block

This manifold is for multiple-cylinder installations, has four 3/8" NPTF ports and two 1/4" mounting holes. Wt. 1.5 lbs.

No. 9635 – Manifold block

This hex-shaped manifold offers extra versatility with six 3/8" NPTF ports and two 1/4" mounting holes. Wt. 2 lbs.

No. 9617 – Manifold block

When a multiple-cylinder installation is required, this manifold is invaluable. Has six 3/8" NPTF ports to handle larger multiple-cylinder systems. Wt. 3 lbs.

No. 9648 – Manifold block

This 7" long manifold block has seven 3/8" NPTF ports and two 1/4" mounting holes. Wt. 2.7 lbs.

No. 9627 – Manifold block

This 16" long manifold block allows you to mount the 9575 or 9596 valves without interference. Has seven 3/8" NPTF ports and two 1/4" mounting holes. Wt. 6 lbs.

No. 9626 – Pump mounted manifold block

Converts pumps with pump mounted valves for use with remote mounted valves. This manifold block is subplate mounted on the pump cover plate and provides 3/8" NPTF pressure and return ports. Maximum recommended flow rate is 5 gpm. Note: If used on PE30

or PG30 series pump, 1/2" longer mounting screws are required. Order four (4) No. 11956 screws separately.

9642 AND 9644 MANIFOLD BLOCKS WITH NEEDLE VALVES

For independent multiple-cylinder operation, feature needle valves for precise manual control. Designed for remote-mounted applications. Can be used with all Power Team pumps.

No. 9642 – Manifold with two needle valves for control of two cylinders. Has four 3/8" NPTF ports. Wt. 8.2 lbs.

No. 9644 – Manifold with four needle valves for control of four cylinders. Has six 3/8" NPTF ports. Wt. 16.2 lbs.

FITTINGS

10,000 PSI

Hydraulic fittings:
All applications.



	9190	Hyd. tubing. $\frac{3}{8}$ " O.D. x .065" wall, 50 ft. (10 pieces 5 feet long.) Wt. 12 lbs.
	9670	Tee adapter. For installing gauge between pump and hose coupling. Has $\frac{1}{4}$ " and $\frac{3}{8}$ " NPTF female and $\frac{3}{8}$ " NPTF male ports. Wt. 0.5 lb.
	9671	Double tee adapter. Permits use of more than one cylinder in series with one pump. Three $\frac{3}{8}$ " NPTF female ports. Wt. 1 lb.
	9672	Service tee. Two $\frac{3}{8}$ " NPTF female internal, one $\frac{3}{8}$ " NPTF male external. Wt. 0.6 lb.
	9673*	Swivel connector. $\frac{3}{8}$ " NPSM male, $\frac{1}{4}$ " NPSM female. Wt. 0.2 lb.
	9674	Male connector. $1\frac{11}{16}$ " long, $\frac{1}{4}$ " x $\frac{3}{8}$ " NPTF. Wt. 0.2 lb.
	9675*	Swivel connector. $\frac{3}{8}$ " NPTF male, $\frac{3}{8}$ " NPSM female. Wt. 0.2 lb.
	9676*	Swivel connector. $\frac{1}{4}$ " NPTF male, $\frac{3}{8}$ " NPSM female. Wt. 0.2 lb.
	9677*	45° swivel connector. $\frac{3}{8}$ " NPTF male, $\frac{3}{8}$ " NPSM female. Wt. 0.3 lb.
	9678	45° fitting. Used when mounting gauge at an angle on connection such as 9670. Male and female $\frac{1}{4}$ " NPTF ends. Wt. 0.3 lb.
	9679	Connector. $\frac{1}{4}$ " NPTF female and $\frac{3}{8}$ " NPTF male. Wt. 0.1 lb.
	9680	Coupling. Both ends $\frac{3}{8}$ " NPTF female. Wt. 0.2 lb.
	9681	Street elbow. Male and female $\frac{3}{8}$ " NPTF ends. Wt. 0.3 lb.
	9682	Male connector. $1\frac{11}{16}$ " long, $\frac{3}{8}$ " NPTF male ends. Wt. 0.1 lb.

	9683	Male connector. $2\frac{1}{4}$ " long, $\frac{3}{8}$ " NPTF male ends. Wt. 0.2 lb.
	9684	Male connector. $2\frac{1}{4}$ " long, $\frac{1}{4}$ " NPTF male ends. Wt. 0.2 lb.
	9685	Coupling. $\frac{1}{4}$ " NPTF female and $\frac{3}{8}$ " NPTF female. Wt. 0.2 lb.
	9686	90° elbow. $\frac{3}{8}$ " NPTF female ends. Wt. 0.4 lb.
	9687	Pipe plug. Heat-treated, $\frac{3}{8}$ " NPTF. Wt. 0.1 lb.
	9688	Pipe plug. Heat-treated, $\frac{1}{4}$ " NPTF. Wt. 0.1 lb.
	9689	Connector. $\frac{1}{4}$ " NPTF male and $\frac{3}{8}$ " NPTF female. Wt. 0.2 lb.
	9690	Male connector. $1\frac{11}{16}$ " long, $\frac{1}{4}$ " NPTF male ends. Wt. 0.1 lb.
	9692	Straight connector. $\frac{3}{8}$ " tube x $\frac{3}{8}$ " male NPTF. Wt. 0.2 lb.
	9693	90° elbow. $\frac{3}{8}$ " tube x $\frac{3}{8}$ " male NPTF. Wt. 0.2 lb.
	9694	45° elbow. $\frac{3}{8}$ " tube x $\frac{1}{4}$ " male NPTF. Wt. 0.2 lb.
	9695	Tee. $\frac{3}{8}$ " tube. Wt. 0.3 lb.
	9696	Male run tee. $\frac{3}{8}$ " tube x $\frac{1}{4}$ " male NPTF. Wt. 0.3 lb.
	9697	Male branch tee. $\frac{3}{8}$ " tube x $\frac{1}{4}$ " male NPTF. Wt. 0.3 lb.
	9698	Cross. $\frac{3}{8}$ " tube. Wt. 0.4 lb.
	9699	45° gauge fitting. $\frac{3}{8}$ " NPTF male and female, and $\frac{1}{4}$ " NPTF female at 45°. Wt. 0.6 lb.
	9705	Fitting, swivel. $\frac{3}{8}$ " NPTF male to $\frac{3}{8}$ " NPTF female. 90° fitting with internal 370 micron screen. May be rotated 360° about male thread axis.

NOTE: Power Team hydraulic fittings are intended for use with our high pressure hydraulic products and are suitable for use at max. working pressures of 10,000 psi unless otherwise noted.

*** ⚠ CAUTION: On part numbers 9673, 9675, 9676 and 9677 the female swivel end of these adapters is a straight pipe thread (NPSM) with a 30° seat. All male pipe fittings that are used with these female swivel adapters must have an internal 30° seat in order to effect a proper seal. All Power Team male fittings are manufactured with a 30° seat except 9687 and 9688.**



VALVES

Remote/In-Line Valve selection chart

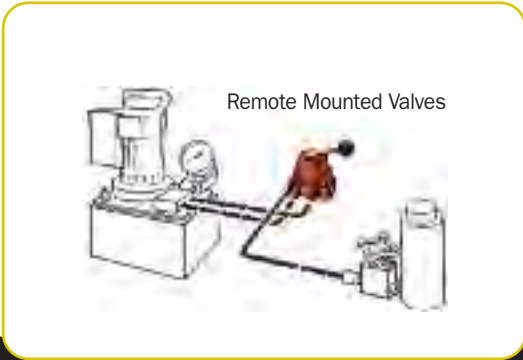

Order No.	Page No.	*Cylinder Application	Operation	Valve Type	Volt	Advance/Return	Advance/ Hold Return	Posi-Check® Feature
9508	117	S.A. & D.A.	Manual	4-way, 3 Pos. Closed Center	—	no	yes	yes
9509	117	S.A. & D.A.	Manual	4-way, 3 Pos. Tandem Center	—	no	yes	yes
9514	117	D.A.	Solenoid	4-way, 3 Pos. Tandem Center	115	no	yes	yes
9524	116	S.A. & D.A.	Solenoid	3/4-way, 2 Pos.	230	no	yes	no
9525	117	D.A.	Solenoid	4-way, 3 Pos. Tandem Center	230	no	yes	yes
9526	117	S.A.	Solenoid	3-way, 2 Pos.	230	no	yes	no
9554	116	S.A. & D.A.	Solenoid	3/4-way, 2 Pos.	24	no	yes	no
9555	117	D.A.	Solenoid	4-way, 3 Pos. Tandem Center	24	no	yes	yes
9556	117	S.A.	Solenoid	3-way, 2 Pos.	24	no	yes	no
9559	117	S.A.	Solenoid	3-way, 2 Pos.	115	no	yes	no
9593	116	S.A. & D.A.	Solenoid	3/4-way, 2 Pos.	115	no	yes	no
9595	116	S.A. & D.A.	Air	3/4-way, 2 Pos.	—	no	yes	no

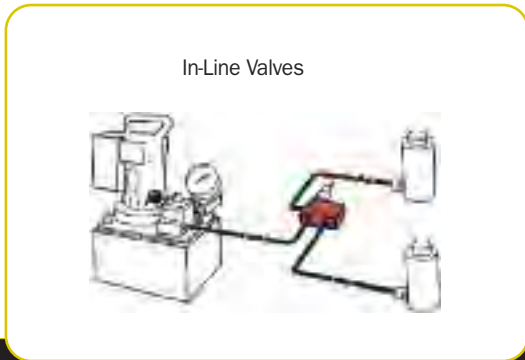

Order No.	Page No.	*Cylinder Application	Operation	Valve Type	Volt	Advance/Return	Advance/ Hold Return	Posi-Check® Feature
9575	118	S.A.	Manual	Shut-Off Valve	—	—	—	—
9580	119	S.A.	Automatic	One-way Check Valve	—	—	—	—
9581	119	S.A. & D.A.	Automatic	Pilot Op. Check Valve	—	—	—	—
9596	118	S.A.	Manual	Load Lowering Valve	—	—	—	—
9597	118	S.A. & D.A.	Automatic	Sequence Valve	—	—	—	—
9608	118	S.A. & D.A.	Automatic	Pressure Reducing Valve	—	—	—	—
9623	119	S.A. & D.A.	Automatic	Pressure Relief Valve	—	—	—	—
9631	119	S.A. & D.A.	Automatic	Metering Valve	—	—	—	—
9633	119	S.A. & D.A.	Automatic	Pressure Regulator Valve	—	—	—	—
9720	118	S.A. & D.A.	Automatic	Counter Balance Valve	—	special	—	—
9721	118	S.A. & D.A.	Automatic	Counter Balance Valve	—	special	—	—
RV21278	119	—	Automatic	Relief Valve	—	—	—	—

*S.A." represents single-acting cylinders, "D.A." represents double-acting cylinders.
For pump-mounted valves, see pages 51-57.

VALVES

Remote Mounted

10,000 psi.,

1/4" ports 5 gpm max flow

9593
9524
9554

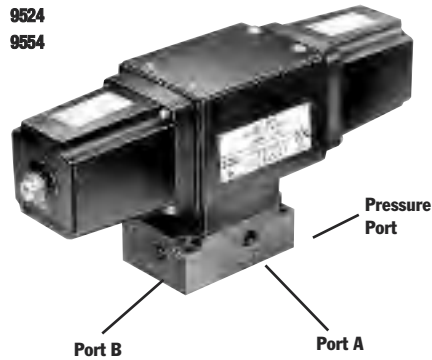

9595

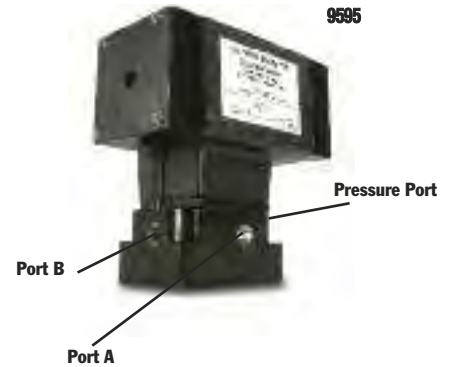

3/4-WAY/2-POSITION SOLENOID AND AIR ACTUATED VALVES

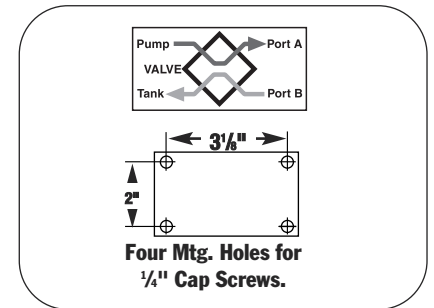
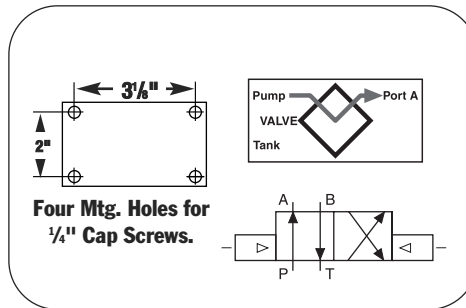

Application: Single- or double-acting cylinders.

Actuation: 9593, 9524 and 9554 are solenoid operated, 9595 is air operated.

Operation with single-acting cylinder: Either oil port "A" or "B" must be plugged on valve. With port "B" plugged, solenoid is energized to position "A," oil port "A" becomes pressurized. When solenoid is energized to position "B," oil port "A" becomes the return port.

Operation with multiple single-acting cylinders: A pressure line from one bank can be connected to oil port "A" and the other to oil port "B" on the valve. Sequence: When energized to position "A," oil port "A" becomes pressurized and clamps the fixture connected to oil port "A"; oil port "B" becomes a "return" port for cylinder connected to oil port "B," and retracts it. The opposite happens when solenoid "B" is energized.

Operation with double-acting cylinder: Port "A" is connected to "advance" port of cylinder, oil port "B" connects to cylinder "return" port. Solenoid is energized to position "A," oil port "A" becomes pressurized to extend cylinder piston. The opposite happens when solenoid "B" is energized. Valve does not hold in "retract" position.

NOTE: When using more than one valve on a pump, the tank port may require a check valve to permit inadvertent, momentary extension of a retracted cylinder.

NOTE: If pump is equipped with an internal outlet check, a "hold" position can be maintained with the pump shut off.

No. 9593 – 3/4-way/2-position, remote mounted solenoid valve, 115 volt, 50/60 Hz. Wt., 15.4 lbs.

No. 9524 – Same as 9593 except with 230 volt, 50/60 Hz.

No. 9554 – Same as 9593 except with 24 volt, 50/60 Hz.

No. 9595 – Same as 9593 except is air operated (minimum of 50 psi air pressure required). Wt., 11.4 lbs.

NOTE: Valves above are shipped without controls. The 9524, 9554 and 9593 can be used with the 304718 remote hand control (see page 130). The 9595 can be used with the 209593 remote hand control (see page 130).

NOTE: Valves have 1/4" NPTF ports. 3/8" to 1/4" adapters are included.

NOTE: Maximum tank line pressure for remote mounted valves is 500 psi.

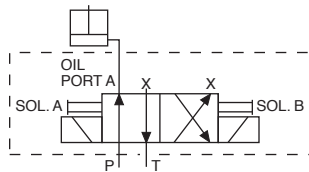

1. To actuate one single-acting cylinder.

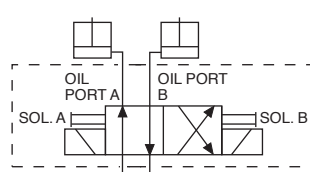

2. To actuate two single-acting cylinders.

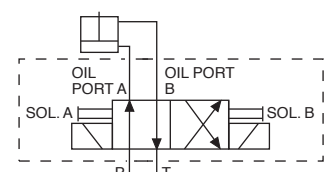

3. To actuate one double-acting cylinder.

NOTE: Valves above are shipped without control switch. Use 202777 remote hand switch (see page 130).

CAUTION: To prevent sudden, uncontrolled descent of a load as it is being lowered, use a No. 9596 Load Lowering Valve or No. 9720 Counter Balance Valve (see page 118) in conjunction with the directional valve used in your application.

VALVES

Remote Mounted

10,000 psi.,

3/8" ports 5 gpm max flow

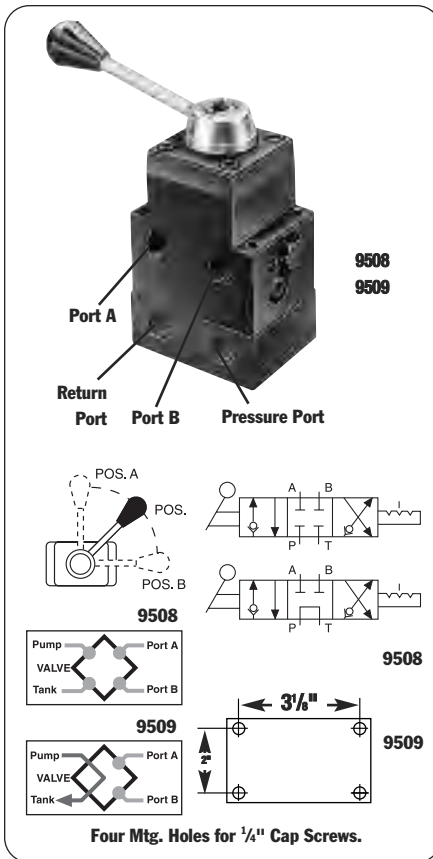

4-way/3-position (closed center) and (tandem center) manual valves with Posi-Check®

Application: Single- or double-acting cylinders. When used with single-acting cylinders, one port must be plugged. For double-acting cylinders, either port can be used for “advance” or “return.”

Actuation: Lever-operated, detent positioned.

Functions: The 9508 provides “advance,” “hold” and “return” positions with all ports blocked (closed center) in the “hold” position. The 9509 has “advance,” “hold” and “return” with tandem center (cylinder ports are blocked, pump remains running). Both valves have “Posi-Check®” feature to guard against pressure loss when shifting from “advance” to “hold.”

No. 9508 – 4-way/3-position (closed center) manual valve, including subplate for remote mounting. Wt., 6.3 lbs.

No. 9509 – Same as 9508, except is tandem center.

CAUTION: To prevent sudden, uncontrolled descent of a load as it is being lowered, use a No. 9596 Load Lowering Valve or No. 9720 Counter Balance Valve (see page 118) in conjunction with the directional valve used in your application.

CAUTION: The Posi-Check® feature will not hold the load when shifted directly A to B-B to A or from hold to A or B.

NOTE: Maximum tank line pressure for remote mounted valves is 500 psi.



3-WAY/2-POSITION SOLENOID VALVE

Application: Single-acting cylinders.

Actuation: Solenoid operated, 115 volt, 50/60 Hz.

Function: Advances cylinder piston when solenoid is de-energized, and pump is running. When solenoid is energized, oil is directed back through valve “return” port and cylinder piston returns. To place cylinder in “hold” position, pump must be stopped or its flow held at the valve “pressure” port with the solenoid de-energized.

NOTE: Valve is equipped with a 9631 snubber valve in port “A.” The line from the “return” port of the valve must be unrestricted (100 psi back pressure maximum) back to the reservoir. IMPORTANT: A 9580 in-line check valve (see page 119) must be installed in the “pressure” port if the supply pump is not equipped with an outlet check valve.

No. 9559 – 3-way/2-position solenoid valve, 115 volt 50/60 Hz. Includes a remote mounting subplate. Wt., 9.7 lbs.

No. 9526 – Same as 9559 except for 230 volt, 50/60 Hz.

No. 9556 – Same as 9559 except for 24 volt, 50/60 Hz.

NOTE: Valves above are shipped without control switch. Use 202777 remote hand switch (see page 130).

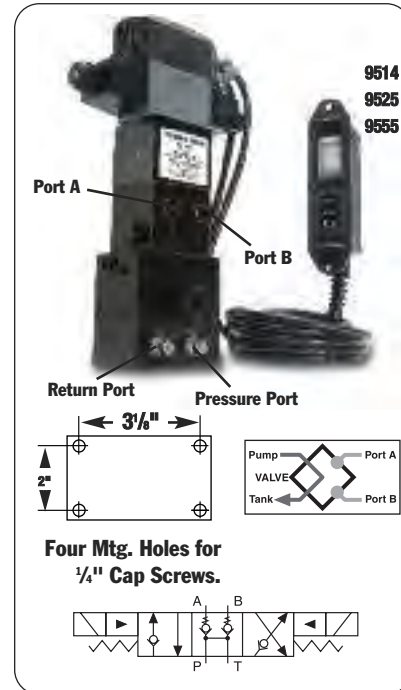

4-way/3-position (tandem center) solenoid valve with Posi-Check®

Application: Double-acting cylinders.

Actuation: Solenoid operated, 115 volt, 50/60 Hz.

Functions: Push button control of “advance,” “hold” and “return.” The “Posi-Check®” feature guards against pressure loss when shifting from “advance” to “hold.” With valve in “hold” position, cylinder ports are blocked and oil is directed from pump to reservoir. NOTE: Do not allow return tank pressure to exceed 500 psi at the valve.

No. 9514 – 4-way/3-position (tandem center) solenoid valve, 115 volt, 50/60 Hz. Remote hand control included. Wt., 10.1 lbs.

No. 9525 – Same as 9514 except for 230 volt, 50/60 Hz.

No. 9555 – Same as 9514 except for 24 volt, 50/60 Hz.

NOTE: Consult factory before installing a pressure switch on any of these valves.

ACCESSORIES



VALVES HYDRAULIC IN-LINE

10,000 psi.
5 gpm max flow rate

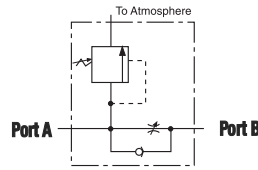

LOAD LOWERING VALVE

Application: Precision metering for controlled cylinder piston return.

Operation: Permits free flow when extending cylinder, built-in pressure relief and "Posi-Check" locks and holds load in raised position until operator opens valve. May be pre-set to provide consistent metered return, or operator may select rate of return with each actuation. Has 3/8" NPTF ports.

NOTE: Pressure relief valve setting is 12,000 psi. Operating pressure is 10,000 psi and max. flow rate is 5 gpm.

No. 9596 – Load lowering valve. Wt., 2.1 lbs.

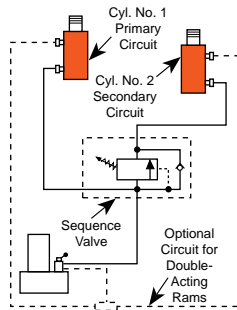
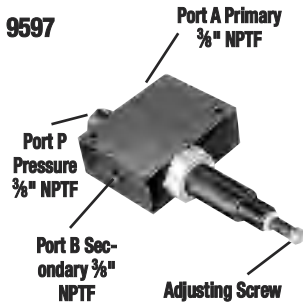

SEQUENCE VALVE

Application: Used when one cylinder in a multi-cylinder application must advance before any other.

Operation: Pump is connected to port "P" and separate cylinders to ports "A" and "B". When pressure is applied to port "P", cylinder "A" advances. Cylinder "B" will not advance until a predetermined pressure setting is reached in cylinder "A". Pressure setting is adjustable from 500 to 8,000 psi with adjustment screw; factory preset at 1,000 psi. Has 3/8" NPTF ports.

No. 9597 – Pressure control sequencing valve. Wt., 5.6 lbs.

9608

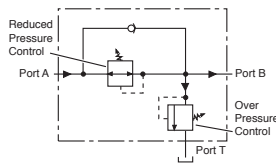
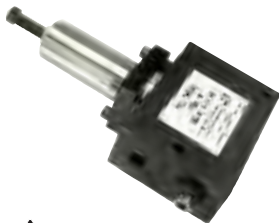

PRESSURE REDUCING VALVE

Application: Provides complete, independent pressure control to two or more clamping systems operated by a single power source.

Operation: Can be used to provide different pressures in various stages of a single system. Virtually zero leakage across valve means each system can be operated by a single continuous pressure source. Adjustable from 1,000 to 5,000 psi at outlet port "B" (secondary). Has 1/4" NPTF ports.

No. 9608 – Pressure reducing valve. Wt., 5.8 lbs.

CAUTION: Over Pressure control must be set at a higher value than operating pressure.

9720

9721

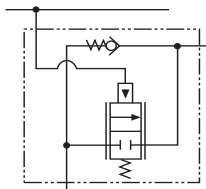

COUNTER BALANCE VALVE

Application: Double-acting cylinders. Provides positive holding and controlled, "chatter-free" lowering of a load.

Operation: Load is raised at flow rate of pump, and held when pump is shut off. When the pump is shifted to "retract", the counter balance valve will continue to hold the load until system pressure exceeds pressure caused by load. The load can then be lowered smoothly to the flow rate

of the pump. The counter balance valve is designed to operate with pumps having a high pressure flow rate of up to 120 cu. in./min. and cylinder ratios of 3 to 1.

No. 9720 – Counter balance valve, including two male and two female half two hydraulic hoses, fittings and dust caps. Wt., 10 lbs.

No. 9721 – Same as 9720, but does not include couplers, hoses, fittings and dust caps. Wt., 9.2 lbs.

CAUTION: The 9720 patented counter balance valve has a pilot pressure as high as 3,000 psi. Because this pressure is applied to the rod end of the cylinder while it is already under load, the system should not be sized for loads greater than 80% of cylinder rated capacity.

CAUTION: To prevent sudden, uncontrolled descent of a load as it is being lowered, use a No. 9596 Load Lowering Valve or No. 9720 Counter Balance Valve in conjunction with the directional valve used in your application. See above, this page.

Shut-off valve

Application: This needle valve permits fine metering of hydraulic oil.
Operation: Can be used for controlling multiple single-acting cylinders.

No. 9575 – Shut off valve with $\frac{3}{8}$ " NPTF ports. Wt., 1.4 lbs.



9575

Check valve

Application: Permits flow of hydraulic oil in one direction only.
Operation: Installs right in hydraulic line.

No. 9580 – Check valve with $\frac{3}{8}$ " NPTF male ends. Wt., .4 lb.



9580

Pilot operated check valve

Application: For use with open or tandem center valves. Permits free flow of fluid in one direction.

Operation: Flow is blocked in opposite direction until pilot oil pressure is applied. This prevents the loss of pressure if the valve is inadvertently shifted or the pump line is broken. Minimum cracking pressure is 60 psi. Required pilot pressure is approximately 16% of checked system pressure.

No. 9581 – Pilot operated check valve with $\frac{3}{8}$ " NPTF ports. Wt., 3.8 lbs.



9581

"In-line" pressure relief valve

Application: Single- or double-acting cylinders. For remote locations in a hydraulic circuit where maximum pressure requirements are less than basic overload valve setting in pump.

Operation: Adjustable from 1,000 to 10,000 psi. Valve is spring-loaded and direct-acting.

No. 9623 – Pressure relief valve with $\frac{3}{8}$ " NPTF ports. Wt., 2 lbs.

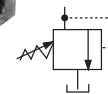

9623

Metering valve

Application: For systems using large cylinders or extended lengths of hydraulic hose.

Operation: Controls surges by restricting flow if it exceeds 7 gpm. When flow subsides, valve reopens automatically. Has $\frac{3}{8}$ " NPTF male end to thread into return port of system control valve, and a $\frac{3}{8}$ " NPTF female end, permitting return hose to be directly connected.

No. 9631 – Metering valve. Wt., 0.2 lb.



9631

"In-line" pressure regulator valve

Application: Single- or double-acting cylinders. Permits adjusting operating pressures at various values below relief valve setting of pump.

Operation: Regulator valve is easily adjusted to maintain pressures between 300 and 10,000 psi. Maintains a given pressure setting within 3% over repeated cycles. Flow range is 17 cu. in./minute to 6 gpm.

No. 9633 – In-line pressure regulator valve with two $\frac{3}{8}$ " NPTF inlet ports, one $\frac{1}{8}$ " NPTF tank port and 3 foot drain line kit. Wt., 1.9 lbs.

Simply turn the handle clockwise to increase the pressure setting, counter-clockwise to reduce pressure.

Note: 3' Drain Line Kit is included.

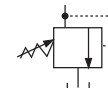

9633



ACCESSORIES

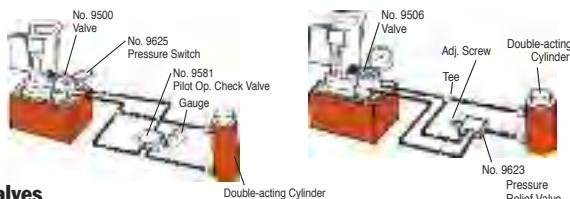

Relief valves

Application: Provide an economical means of protecting an hydraulic circuit against over pressurization.

Operation: These factory preset valves are designed for maximum flow rate of 5 gpm. Furnished with $\frac{1}{8}$ " NPTF male port. All valves weigh 0.2 lb. See chart to the right for ordering information.



RV21278 Series

NOTE: Care should be exercised to protect workers from hot, pressurized hydraulic oil. Install these valves only in an enclosed or shielded area.

Valve Order No.	Pressure Setting (psi)	Valve Order No.	Pressure Setting (psi)
RV21278	10,100 / 10,700	RV21278-50	5,100 / 5,700
RV21278-6	600 / 640	RV21278-52	5,300 / 5,900
RV21278-10	900 / 1,000	RV21278-55	5,600 / 6,200
RV21278-15	1,500 / 1,700	RV21278-57	5,800 / 6,400
RV21278-17	1,600 / 1,800	RV21278-60	6,100 / 6,700
RV21278-20	1,900 / 2,200	RV21278-65	6,600 / 7,200
RV21278-25	2,300 / 2,700	RV21278-70	7,100 / 7,700
RV21278-27	2,600 / 2,800	RV21278-75	7,600 / 8,200
RV21278-28	2,700 / 3,000	RV21278-80	8,100 / 8,700
RV21278-30	3,000 / 3,400	RV21278-83	8,400 / 9,000
RV21278-32	3,100 / 3,300	RV21278-86	8,700 / 9,300
RV21278-35	3,500 / 3,800	RV21278-88	8,900 / 9,600
RV21278-38	3,750 / 3,950	RV21278-90	9,100 / 9,700
RV21278-40	4,100 / 4,500	RV21278-114	11,500 / 12,100
RV21278-43	4,400 / 4,800	RV21278-6280	6,380 / 6,900
RV21278-48	4,900 / 5,300		

Preset — Non-Serviceable

VALVE SELECTION

Choosing the Right Valve

CONSIDERATIONS:

- Will the valve be used with single- or double-acting cylinders?
- Will the valve be mounted on the pump, away from the pump or directly into the hydraulic lines?

- Will the valve be manually-operated or is remote control preferred?
- Is independent control of multiple cylinders, or hydraulics tools preferred?
- What directional control and pressure control valve functions are needed for the application?



Basic valve types include manually operated, air or solenoid operated and pilot operated. Special application valves for pre-stressing and post-tensioning are also offered. Consult selection chart on page 50 for listings of all Power Team valves.

- Step 1-** Select the hydraulic cylinder that best suits the application. See pages 6-8.
- Step 2-** Select the series of hydraulic pump with adequate oil output and reservoir capacity to power cylinder. See pages 42-45. Check speed chart on page 6.
- Step 3-** Select pump within series with the valve option that is best matches cylinder, pump and application. See pages 122-127.

DIRECTIONAL CONTROL VALVES



2-WAY, 2-POSITION

(FOR CONTROL OF SINGLE-ACTING CYLINDERS):

POSITION 1	CENTER POSITION	POSITION 2
 <p>Oil goes from pump to cylinder; pressure is held from valve to cylinder when pump is shut off.</p>	None	 <p>Oil goes from pump to cylinder; pressure is released to reservoir when motor is turned off.</p>



3-WAY, 2-POSITION

(FOR CONTROL OF SINGLE-ACTING CYLINDERS)

POSITION 1	CENTER POSITION	POSITION 2
 <p>Oil goes from pump to cylinder and holds when pump is shut off. Return line to reservoir is blocked.</p>	None	 <p>Cylinder retracts, oil returns to reservoir.</p>

3-WAY, 3-POSITION

(FOR CONTROL OF SINGLE-ACTING CYLINDERS)

POSITION 1	CENTER POSITION	POSITION 2
 <p>Oil goes from pump to cylinder and holds when pump is shut off. Return line to reservoir is blocked.</p>	 <p>Cylinder pressure is held; pump can remain running and oil returns to reservoir.</p>	 <p>All oil is open to reservoir through return line.</p>

ACCESSORIES



IN-LINE HYDRAULIC VALVES

Load Lowering Valve – Provides precision metering for controlled return of the cylinder piston.

Sequence Valve – Used when a cylinder in a multiple cylinder application must advance before any other.

Pressure Reducing Valve – Permits independent pressure control to two or more clamping systems operated by a single power source.

Shut-off Valve – For fine metering of hydraulic oil. Several may be used to control multiple single-acting cylinders.

Check Valve – Permits flow of hydraulic oil in one direction only.

Pressure Relief Valve – Used at remote locations in a hydraulic circuit where maximum pressure requirements are less than the setting of the basic overload valve in the pump. Protects a hydraulic system against over pressurization.



Metering Valve – Restricts surges by restricting flow to a certain level; when flow subsides, valve reopens automatically. For systems using large cylinders or extended lengths of hose.

Pressure Regulator Valve – Permits external adjustment of operating pressures at various values below the internal relief valve setting of the pump.

DIRECTIONAL CONTROL VALVES

4-WAY, 2-POSITION

(FOR CONTROL OF SINGLE- OR DOUBLE-ACTING CYLINDERS):



POSITION 1	CENTER POSITION	POSITION 2
 <p>Oil goes to the “extend” side of the cylinder. The oil from the “retract” side returns to reservoir. Cylinder holds with pump shut off.</p>	<p>None</p>	 <p>Oil goes to the “retract” side of the cylinder, oil from the “extend” side returns to reservoir.</p>

ACCESSORIES





4-WAY, 3-POSITION

(FOR CONTROL OF DOUBLE-ACTING CYLINDERS)

POSITION 1	CENTER POSITION	POSITION 2
 <p>Oil goes to the “extend” side of the cylinder, oil from the “retract” side returns to reservoir. Cylinder holds with pump shut off.</p>	 <p>Holds pressure even if pump is running. Oil from pump goes through valve, back to reservoir.</p>	 <p>Oil goes to “retract” side of cylinder. Oil from “extend” side returns to the reservoir.</p>

TYPICAL CENTERS

TANDEM CENTER	CLOSED CENTER	OPEN CENTER
 <p>Cylinder ports are blocked, oil from pump goes to reservoir. Used when pump remains running. Example: gasoline-driven pumps.</p>	 <p>Generally used when running multiple valves in series from one pump.</p>	 <p>Open Center Used when holding is not a requirement, as when running tow separate hydraulic tools such as cutters and crimpers.</p>

VALVES

Selection Information Pump Mounted Valves

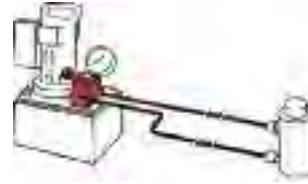

PUMP MOUNTED VALVES

Order No.	Page No.	*Cylinder Application	Operation	Valve Type	Volt	Advance/Return	Advance/ Hold Return	Posi-Check® Feature
9500	125	S.A. & D.A.	Manual	4-way, 3 Pos. Tandem Center	—	no	yes	no
9501	125	S.A. & D.A.	Manual	4-way, 3 Pos. Closed Center	—	no	yes	no
9502	124	S.A.	Manual	3-way, 3 Pos. Closed Ctr.	—	no	yes	yes
9504	123	S.A. & D.A.	Manual	3/4-way, 2 Pos.	—	yes	yes	no
9506	125	D.A.	Manual	4-way, 3 Pos. Tandem Center	—	no	yes	yes
9507	125	D.A.	Manual	4-way, 3 Pos. Closed Center	—	no	yes	yes
9511	125	S.A. & D.A.	Manual	4-way, 3 Pos. Open Center	—	yes	yes	no
9512	128	D.A.	Solenoid	4-way, 3 Pos. Tandem Center	24	no	yes	yes
9513	128	D.A.	Solenoid	4-way, 3 Pos. Tandem Center	115	no	yes	yes
9516	128	D.A.	Solenoid	4-way, 3 Pos. Tandem Center	12DC	no	yes	yes
9517	123	S.A.	Manual	2-way, 2 Pos.	—	no	yes	no
9519	128	D.A.	Solenoid	4-way, 3 Pos. Tandem Center	230	no	yes	yes
9520	124	S.A.	Manual	4-way, 3 Pos. Tandem Center	—	no	yes	yes
9522	128	D.A.	Solenoid	4-way, 3 Pos. Open Center	230	yes	no	no
9523	128	S.A.	Pilot Operated Solenoid	3-way, 2 Pos.	230	yes	no	no
9552	127	S.A. & D.A.	Solenoid	3/4-way, 2 Pos.	230	yes	no	no
9553	128	S.A.	Pilot Operated Solenoid	3-way, 2 Pos.	24	yes	no	no
9569	128	S.A.	Solenoid	3-way, 2 Pos.	24	no	yes	no
9570	128	S.A.	Solenoid	3-way, 2 Pos.	230	no	yes	no
9572	128	S.A. & D.A.	Solenoid	3/4-way, 2 Pos.	24	yes	no	no
9576	124	S.A.	Manual	3-way, 3 Pos. Metering Tandem Ctr.	—	no	yes	no
9579	127	S.A.	Solenoid	3-way, 2 Pos.	115	no	yes	no
9582	123	S.A.	Manual	3-way, 2 Pos.	—	no	yes	no
9584	123	S.A.	Manual	3-way, 2 Pos.	—	no	yes	no
9589	128	S.A.	Pilot Operated Solenoid	3-way, 2 Pos.	115	yes	no	no
9590	128	D.A.	Solenoid	4-way, 3 Pos. Open Center	115	yes	no	no
9592	127	S.A. & D.A.	Solenoid	3/4-way, 2 Pos.	115	yes	no	no
9594	127	S.A. & D.A.	Air	3/4-way, 2 Pos.	—	no	yes	yes
9599	126	S.A.	Pilot Operated Solenoid	3-way, 3 Pos. Tandem Center	24	no	yes	yes
9605	126	S.A.	Pilot Operated Solenoid	3-way, 3 Pos. Tandem Center	115	no	yes	yes
9609	126	S.A.	Manual	3-way, 3 Pos. Tandem Center	—	no	yes	no
9610	123	S.A.	Auto Pilot Operated	3-way, 2 Pos.	—	yes	no	no
9610A	123	S.A.	Manual	2/3-way, 2 Pos.	—	no	yes	no
9615	128	D.A.	Solenoid	4-way, 3 Pos. Open Center	24	yes	no	no
9628	129	S.A. & D.A.	Manual	Post Tensioning	—	special	no	no
9632	129	S.A. & D.A.	Manual	Post Tensioning	—	special	no	no

* "S.A." represents single-acting cylinders, "D.A." represents double-acting cylinders

ACCESSORIES



3-WAY/2-POSITION MANUAL VALVES

Applications – Single-acting cylinders. **Actuation** – Lever operated.

Functions – Cylinder piston “advance”, “hold” and “return”.

Used on these pumps – P460, PE17, PE21, PE30, PE46, PE55, PE84, PE90, and PE120 series.

No. 9582 – 3-way/2-position manual valve. Wt. 2.5 lbs.

No. 9584 – Same as 9582, but has “flipper” control. Wt., 1.8 lbs.

3-WAY/2-POSITION, PILOT OPERATED AUTOMATIC VALVE

Application – Single-acting cylinders. Actuation: Pilot oil.

Functions – When pump is started, pilot oil automatically closes valve and directs oil to cylinder; when pump is stopped, valve automatically opens and oil returns to reservoir. **Used on these pumps** – Furnished with pilot lines and adapters for PA55, PA90, PE30, PE55, PE90 and PE120 series.

No. 9610 – 3-way/2-position pilot operated automatic valve. Wt., 4.2 lbs.

2/3-WAY/2-POSITION MANUAL/PILOT OPERATED AUTOMATIC VALVE

Application – Manual operation for load lifting and holding with single-acting cylinders; automatic “dump” for operating hydraulic tools. **Actuation** – Flipper lever/pilot oil. **Functions** – With lever in closed position, valve will hold the load. When lever is “open”, valve functions as a true automatic “dump” valve. **Used on these pumps** – Furnished with pilot lines and adapters for PA55, PA90, PE30, PE55, PE90 and PE120 series. For application on other pumps, consult factory.

No. 9610A – 2/3-way/2-position manual/pilot operated automatic valve. Wt., 4.4 lbs.

2-WAY/2-POSITION MANUAL VALVE

Application – Single-acting cylinders. **Actuation** – Flipper lever operated.

Functions – Cylinder piston “advance”, “hold” and “retract”.

Used on these pumps – PE172, PA172 and PE84 series.

No. 9517 – 2-way/2-position manual valve. Wt., 3.2 lbs.

3/4-WAY/2-POSITION MANUAL VALVE

Application – Single- or double-acting cylinders. **Actuation** – Lever operated, detent positioned. **Functions** – Pos. 1 – Oil is directed to “advance” side of cylinder, oil from “retract” side goes to reservoir; cylinder “holds” with pump shut off. Pos. 2 – Oil goes to “retract” side of cylinder; cylinder “holds” with pump shut off. When using as a 3-way valve for single-acting cylinders, port “A” or “B” is plugged. See note on page 124 regarding plugging of ports and resulting heat build-up.

Used on these pumps – P460, PA6D, PA17, PA46, PA55, PA60, PE17, PE21, PE30, PE46, PE55, PE84, PE90, PE120, PE200, PE400, PQ60 and PQ120 series.

No. 9504 – 3/4-way/2-position manual valve. Wt., 4.2 lbs.

NOTE: 9504 can be remote mounted with a 9510 subplate (see page 95).

NOTE: A pressure switch and/or gauge may be attached to any valve on this page. (refer to pages 131, 110-111)

CAUTION: To prevent sudden, uncontrolled descent of a load as it is being lowered, use a No. 9596 Load Lowering Valve or No. 9720 Counter Balance Valve (see page 118) in conjunction with the directional valve used in your application.

IMPORTANT: Conversion kit 251528 must be used when mounting any of the valves on this page on PA17 or PE17 pumps.

IMPORTANT: When ordering any valve for a PE30 or PG30 series pump, 1/2" longer mounting screws are required. For valves 9504, 9584, 9610 and 9610A, order four 12001 cap screws. For valve 9582, order two 12001 and two 10856 cap screws.

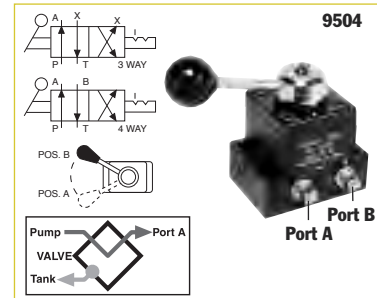
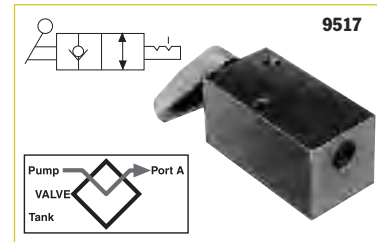
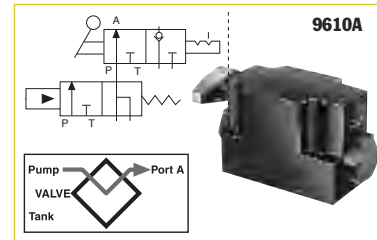
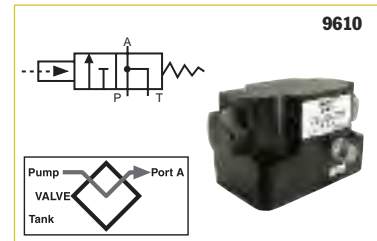
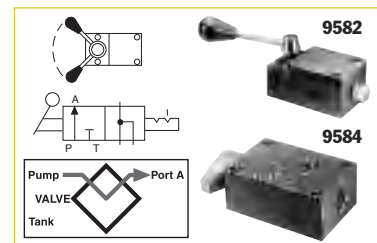

ACCESSORIES



VALVES

Pump Mounted 3 Way/3 Position Manual

**10,000 PSI., 3/8" PORTS,
5 GPM MAX FLOW RATE.**

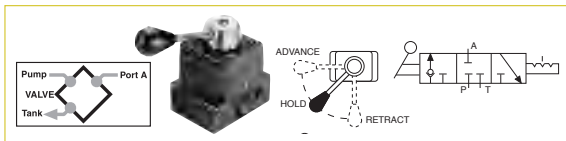

3-WAY/3-POSITION (CLOSED CENTER) NON-INTERFLOW MANUAL VALVE WITH "POSI-CHECK®"

Application – Single-acting cylinders.

Actuation – Lever operated, detent positioned.

Functions – Pos. 1 – Oil is directed from pump to cylinder and "holds" with pump shut off; line to reservoir is blocked. Pos. 2 – All oil is open to reservoir through tank line.

Center pos. – Cylinder pressure is held; pump should be shut off.

Used on these pumps – P460, PA17, PA46, PA55, PA60, PE17, PE21, PE30, PE46, PE55, PE84, PE90, PE120, PE200, PE400, PQ60 and PQ120 series.

NOTE: A pressure switch and/or gauge may be attached if desired (see pages 110-111, 131). Also, the 9502 can be remote mounted if a 9510 subplate is used (see page 131).

No. 9502 – 3-way/3-position (closed center) manual valve. Wt., 4.2 lbs.

9520

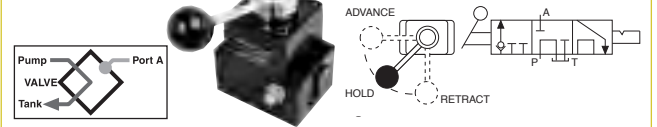

3-WAY/3-POSITION (TANDEM CENTER) MANUAL VALVE WITH "POSI-CHECK®"

Application – Single-acting cylinders.

Actuation – Lever operated, detent positioned.

Functions – "Advance" "hold" and "return". When shifted to "return" position, pump and cylinder return oil through their own separate return lines, allowing faster retraction of piston. The "Posi-Check®" feature guards against pressure loss when shifting from "advance" to "hold" position.

Used on these pumps – P460, PA17, PA46, PA55, PE17, PE21, PE30, PE46, PE55, PE84, PE90, PE120, PQ60, PQ120, PE200, PE400, PG30, PG55, PG120 and PG400 series.

No. 9520 – 3-way/3-position (tandem center) manual valve. Wt., 5.1 lbs.

3-WAY/3-POSITION (TANDEM CENTER) METERING

9576

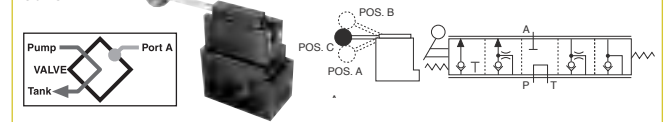

VALVE

Application – Single-acting cylinders.

Actuation – Lever operated.

Functions – Cylinder piston metered "advance", "hold" and metered "return".

Used on these pumps – PA17, PA46, PA55, PE17, PE21, PE30, PE46, PE55, PE84, PE90, PE120, PQ60, PQ120, PE200, PE400, PG30, PG55, PG120 and PG400 series.

NOTE: A pressure switch and/or gauge may be attached if desired see pages 124-125, 117). Also, the 9576 can be remote mounted with a 9510 subplate (see page 131).

No. 9576 – 3-way/3-position (tandem center) metering valve. Wt., 8.5 lbs.

CAUTION: To prevent sudden, uncontrolled descent of a load as it is being lowered, use a No. 9596 Load Lowering Valve or No. 9720 Counter Balance Valve (see page 118) in conjunction with the directional valve used in your application.

NOTE: Valves 9501, 9502, 9504 and 9507 can have a port blocked or have a closed center position. When a port is blocked and the valve is shifted to the blocked port, the pump will generate excessive heat. An electric or rotary air pump can either be turned off manually or with a pressure switch. Reciprocating air pumps may be adjusted to stall out and stop. **NOTE:** Gauge ports monitor pump pressure only, not pressure to the hydraulic cylinder(s).

IMPORTANT: Conversion kit 251528 must be used when mounting any of the valves on this page on PA17 or PE17 pumps.

IMPORTANT: When ordering any valve for a PE30 or PG30 series pump, 1/2" longer mounting screws are required. For valves 9502 and 9520, order four 12001 cap screws. For valve 9576, order four 17428 cap screws.

ACCESSORIES

VALVES

Hydraulic Pump

Mounted

4 Way/3 Position Manual

4-WAY/3-POSITION (TANDEM CENTER) VALVE WITH "POSI-CHECK®"

Application – Single or double-acting cylinders.

Actuation – Lever operated, detent positioned.

Functions – "Advance", "hold" and "return". The "Posi-Check®" feature guards against pressure loss when shifting from "advance" to "hold" position.

Used on these pumps – P460, PA6D, PA17, PA46, PA55, PE17, PE21, PE30, PE46, PE55, PE84, PE90, PE120, PE200, PE400, PED, PG30, PG55, PG120, PG400, PQ60 and PQ120 series

No. 9506 – 4-way/3-position (tandem center) manual valve. Wt., 5.1 lbs.

4-WAY/3-POSITION (TANDEM CENTER) AND (OPEN-CENTER) MANUAL VALVES

Application – Single- or double-acting cylinders.

Actuation – Lever operated, detent positioned.

Functions – The 9500 provides "advance", "hold" and "return". The 9511 (open center) valve can be used if holding is not a requirement, as when running two separate hydraulic tools. Provides "advance" and "return" only.

Used on these pumps – P460, PA17, PA46, PA55, PE17*, PE21, PE30, PE46, PE55, PE84, PE90, PE120, PE200, PE400, PG30, PG55, PG120, PG400, PQ60 and PQ120 series. *Does not mount without 251528

No. 9500 – 4-way/3-position (tandem center) manual valve. Wt., 4.2 lbs.

No. 9511 – Same as 9500, except has an open center.

4-WAY/3-POSITION (CLOSED CENTER) MANUAL VALVE WITH "POSI-CHECK®"

Application – Single- or double-acting cylinders.

Actuation – Lever operated, detent positioned.

Functions – Similar to 9506, but is a closed center valve with "Posi-Check®". Generally used to operate multiple cylinders with a single pump. Provides "advance", "hold" and "return". The "Posi-Check®" feature guards against pressure loss when shifting from the "advance" to "hold" position. See note on page 124 regarding plugging of ports and resulting heat build-up.

Used on these pumps – P460, PA17, PA46, PA55, PA60, PA6D, PE17, PE21, PE30, PE46, PE55, PE84, PE90, PE120, PE200, PE400, PQ60 and PQ120 series.

No. 9507 – 4-way/3-position (closed center) manual valve. Wt., 5 lbs.

4-WAY/3-POSITION (CLOSED CENTER) MANUAL VALVE

Application – Single- or double-acting cylinders.

Actuation – Lever operated, detent positioned.

Functions – "Advance", "hold" and "return". Closed center design makes valve suitable for operating multiple cylinders from a single pump. See note on page 52 regarding plugging of ports and resulting heat build-up.

Used on these pumps – P460, PA17, PA46, PA55, PA60, PE17, PE21, PE30, PE46, PE55, PE84, PE90, PE120, PE200, PE400, PQ60 and P120 series.

No. 9501 – 4-way/3-position (closed center) valve. Wt., 4.2 lbs.

NOTE: A pressure switch and/or gauge may be attached to valves 9500, 9501, 9506, 9511 if desired (see pages 110-111, 131). Also, all valves on this page may be remote mounted with a 9510 subplate (see page 131).

**10,000 PSI., 3/8" PORTS,
5 GPM MAX FLOW RATE.**

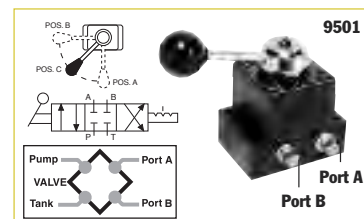
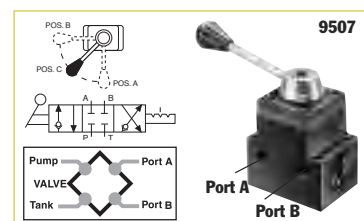
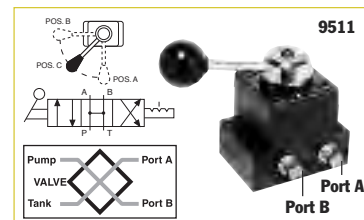
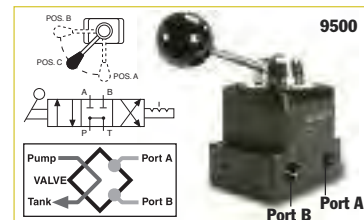
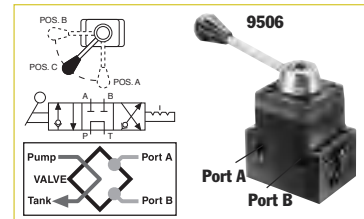

ACCESSORIES



VALVES

Hydraulic Pump

Mounted

Manual and Pilot Operated

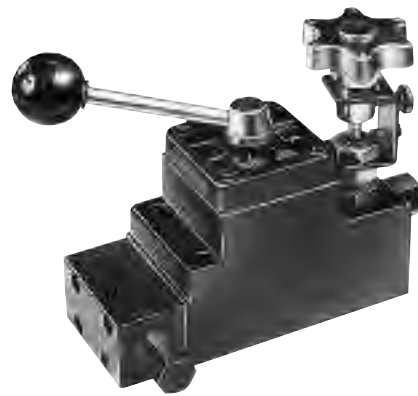

**10,000 PSI., 3/8" PORTS,
5 GPM MAX FLOW RATE.**

9605, 9599



3-WAY/3-POSITION (TANDEM CENTER) SOLENOID VALVES WITH "POSI-CHECK®"

Application – Single-acting cylinders.

Actuation – Solenoid operated: 9605 is 115 volt, 50/60 Hz; 9599 is 24 volt, 50/60 Hz.

Functions – "Advance", "hold" and "return" positions. When in "advance", solenoid "B" is energized and oil goes from pump to cylinder through pressure port. In "return" position, solenoid "A" is energized and oil is directed from cylinder and pump to reservoir. With both solenoids de-energized, in "hold" position, oil from pump is directed back to reservoir while oil is checked in cylinder. The "Posi-Check®" feature holds load when shifting from "advance" to "hold" position.

Used on these pumps – Furnished with pilot lines and adapters for PE55, PE30 (carrying handles must be removed) and PE120 series. For application on other models, consult factory.

No. 9605 – 3-way/3-position (tandem center) solenoid valve, 115 volt, 50/60 Hz. Wt., 14.0 lbs.

No. 9599 – Same as 9605 except for 24 volt, 50/60 Hz circuits.

NOTE: Valves above are shipped without controls. Use 202777 remote hand control (see page 130). Consult factory for field installation.

3-WAY/4-POSITION MANUAL PRESSURE COMPENSATED VALVE

Application – Single-acting cylinders. Primarily for use in testing soil, rock, concrete, asphalt and related engineering materials.

Actuation – Lever and adjustable, pressure compensated flow control valve.

Functions – Cylinder piston "return", "hold", "controlled advance" (pressure compensated) and "advance" (full flow). Will deliver a relatively constant flow regardless of pressure between 1,000 and 10,000 psi.

Used on these pumps – PA17, PA46, PA55, PE17, PE21, PE30*, PE46, PE55, PE90, PE200, PE400, PG30*, PG55, PG120, PG400, PQ60 and PQ120 series. * **NOTE:** Adapter kit 252161 is required for mounting this valve to a PE30 or PG30 series pump.

NOTE: This valve can be remote mounted with a 9510 sub-plate (see page 131).

No. 9609 – 3-way/4-position manual pressure compensated valve. Wt., 8.7 lbs.

CAUTION: To prevent sudden, uncontrolled descent of a load as it is being lowered, use a No. 9596 Load Lowering Valve or No. 9720 Counter Balance Valve (see page 118) in conjunction with the directional valve used in your application.

IMPORTANT: Conversion kit 251528 must be used when mounting the 9609 valve on PA17 or PE17 pumps.

IMPORTANT: When ordering any valve for a PE30 or PG30 series pump, 1/2" longer mounting screws are required. For valves 9500, 9501 and 9511, order four 12001 cap screws. For valve 9552, 9506, and 9507, order four 11956 cap screws. For valves 9599 and 9605, order four 251078 cap screws. For valve 9609, order four 10855 cap screws.

FLOW

Full flow position - 5 gpm (Ref.)
Metered advance position
65 cu. in./min. (Max.)

PRESSURE

Min. working pressure - 1,000 psi.
Max. working pressure - 10,000 psi.
Max. valve case pressure - 500 psi.

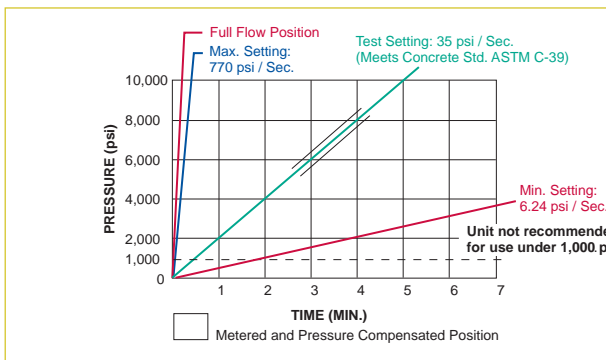

ACCESSORIES



VALVES

Hydraulic Pump Mounted Solenoid or Air Operated

3-WAY/2-POSITION SOLENOID VALVE

Application – Single-acting cylinders. **Actuation** – Solenoid operated, 115 volt, 50/60 Hz.

Functions – Cylinder piston advances when solenoid is de-energized and pump is running. When solenoid is energized, oil is directed to reservoir, and piston returns. For “hold” position, pump is stopped with solenoid de-energized.

Used on these pumps – PE17, PE21, PE30, PE46, PE55, PE84, PE90, PE120, PE200, PE400, PQ60 and PQ120 series.

No. 9579 – 3-way/2-position solenoid valve, 115 volt, 50/60 Hz. Wt., 9.6 lbs.

No. 9569 – Same as 9579, except with 24 volt, 50/60 Hz solenoid.

No. 9570 – Same as 9579 except with 230 volt, 50/60 Hz solenoid.

NOTES: Valves above are shipped without control switch. Use 202777 remote hand switch (see page 130). When this valve is mounted, the pump must be equipped with an outlet check valve.

3/4-WAY/2-POSITION SOLENOID VALVES

Application – Single- or double-acting cylinders. When used with single-acting cylinders, one port should be plugged. **Actuation** – Solenoid operated.

Functions – Oil is directed to “extend” side of cylinder, oil from “retract” side goes to reservoir; cylinder “holds” with pump shut off. Oil is directed to “retract” side of cylinder; oil from “extend” side goes to reservoir.

NOTE: Cylinder will not “hold” in the “return” position with motor running or shut off.

Used on these pumps – 9552, 9572 and 9592 are used with PE17, PE30 (with carrying handles removed), PE46, PE55, PE84, PE90, PE200, PE400, PQ60 and PQ120 series.

No. 9592 – 3/4-way/2-position solenoid valve, 115 volt, 50/60 Hz. Wt., 14.6 lbs.

No. 9552 – Same as 9592, except with 230 volt, 50/60 Hz solenoid.

No. 9572 – Same as 9592, except with 24 volt, 50/60 Hz solenoid.

NOTE: Valves above are shipped without controls. The 9552, 9572 and 9592 can be used with the 304718 remote hand control. (see page 130)

Note: Ports are 1/4" NPTF.

AIR ACTUATED VALVE

Application – Single- or double-acting cylinders. When used with single-acting cylinders, one port should be plugged. **Actuation** – Air operated.

Functions – Oil is directed to “extend” side of cylinder, oil from “retract” side goes to reservoir; cylinder “holds” with pump shut off. Oil is directed to “retract” side of cylinder; oil from “extend” side goes to reservoir.

NOTE: Cylinder will not “hold” in the “return” position with motor running or shut off.

Used on these pumps – PA17, PA46 and PA55 series.

No. 9594 – 3/4-way/2-position solenoid valve, air operated (minimum of 50 psi air pressure required). Wt., 11 lbs.

NOTES: Valve above is shipped without controls. 9594 can be used with the 209593 remote hand control (see page 130). See page 118 for remote mounted models of this valve.

**10,000 PSI., 3/8" PORTS,
5 GPM MAX FLOW RATE.**

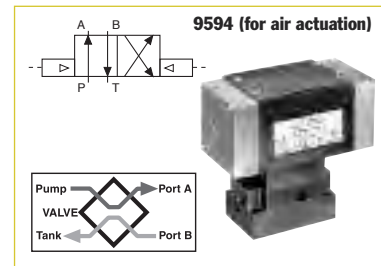
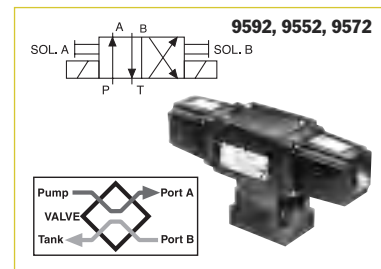
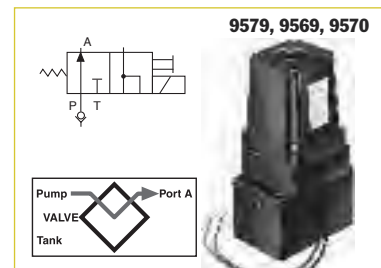

ACCESSORIES



CAUTION: To prevent sudden, uncontrolled descent of a load as it is being lowered, use a No. 9596 Load Lowering Valve or No. 9720 Counter Balance Valve (see page 118) in conjunction with the directional valve used in your application.

IMPORTANT: Conversion kit 251528 must be used when mounting any of the valves on this page on PA17 or PE17 pumps.

IMPORTANT: When ordering any valve for a PE30 or PG30 series pump, 1/2" longer mounting screws are required. For valves 9569, 9570 and 9579, order four 10856 cap screws. For valves 9552, 9572 and 9592, order four 12001 cap screws.

VALVES

Pump Mounted Solenoid or Air Operated



ACCESSORIES

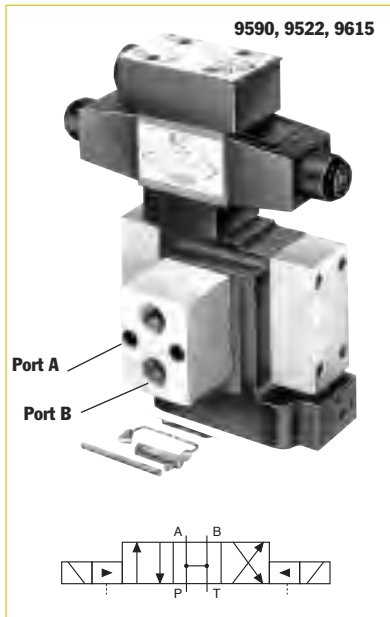

4-WAY/3-POSITION (OPEN CENTER) SOLENOID VALVE

Application – Double-acting cylinders.

Actuation – Solenoid operated, 115 volt, 50/60 Hz.

Functions – “Advance”, open center and “return” positions. Cylinder ports and pump port are open to reservoir in “neutral”.

Used on these pumps – Furnished with pilot lines and adapters for PE30 (with carrying handles removed), PE55, PE90 and PE120 series. For other pump models, consult factory. **NOTE:** A pressure switch and/or gauge may be attached if desired (see pages 111-112, 131).

No. 9590 – 4-way/3-position (open center) solenoid valve, 115 volt, 50/60 Hz. Wt., 15.5 lbs.

No. 9522 – Same as 9590 except for 230 volt, 50/60 Hz.

No. 9615 – Same as 9590 except for 24 volt, 50/60 Hz.

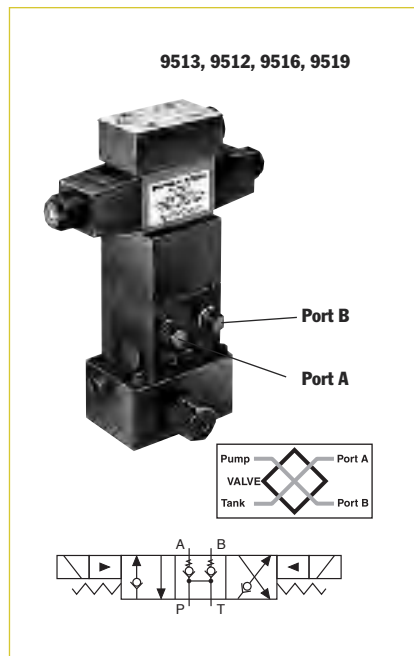

4-WAY/3-POSITION (TANDEM CENTER) PILOT OPERATED SOLENOID VALVE

Application – Double-acting cylinders.
Actuation – Solenoid operated, 115 volt, 50/60 Hz.

Functions – “Advance”, “hold” and “return”. The “Posi-Check” feature holds the load when shifting from the “advance” to the “hold” position.

Used on these pumps – PE17, PE21, PE30 (with carrying handles removed), PE46, PE55, PE84, PE90, PE120, PE200, PE400, PQ60 and PQ120 series. **NOTE:** A gauge may be attached if desired (see pages 111, 112).

No. 9513 – 4-way/3-position (tandem center) solenoid valve, 115 volt, 50/60 Hz. Wt., 18.1 lbs.

No. 9512 – Same as 9513 except for 24 volt, 50/60 Hz circuits.

No. 9516 – Same as 9513 except for 12 volt DC. For use on the PG1204S and PG400 series pumps only.

No. 9519 – Same as 9513 except for 230 volt, 50/60 Hz circuits. Consult factory for field installation.

NOTE: Valves above are shipped without control switch.

CAUTION: To prevent sudden, uncontrolled descent of a load as it is being lowered, use a No. 9596 Load Lowering Valve or No. 9720 Counter Balance Valve (see page 118) in conjunction with the directional valve used in your application.

IMPORTANT: Conversion kit 251528 must be used when mounting the 9609 valve on PA17 or PE17 pumps.

IMPORTANT: When ordering any valve for a PE30 or PG30 series pump, 1/2" longer mounting screws are required. For valves 9513 and 9519, order four 11956 cap screws. For valves 9523, 9553 and 9589, order four 10855 cap screws. For valves 9522, 9590 and 9615, order four 10854 cap screws.



3-WAY/2-POSITION (PILOT OPERATED, NORMALLY OPEN) SOLENOID VALVE

Application: Single-acting cylinders.

Actuation: Solenoid operated, 115 volt, 50/60 Hz.

Function: “Advance” and “return”.

Used on these pumps: Furnished with pilot lines and adapters for PE30 (with carrying handles removed), PE55, PE90 and PE120 series. For other pump models, consult factory. **NOTE:** A pressure switch and/or gauge may be attached if desired (see pages 111-112, 131).

No. 9589 – 3-way/2-position (pilot operated) solenoid valve, 115 volt, 50/60 Hz. Wt., 8.2 lbs.

No. 9523 – Same as 9589 except for 230 volt, 50/60 Hz.

No. 9553 – Same as 9589 except for 24 volt, 50/60 Hz.

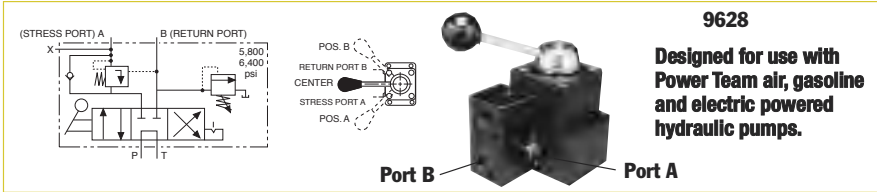

9628

Designed for use with Power Team air, gasoline and electric powered hydraulic pumps.

4-WAY/3-POSITION (TANDEM CENTER) MANUAL VALVE

Application – Single strand, double-acting stressing jacks with Power Wedge seater.

Actuation – Lever operated, detent positioned.

Operation –

1. With valve in center position, pump is started.
2. Cable is inserted into stressing tool, valve is placed in “A” position. “Pull” portion of stressing tool is pressurized to specified level for proper cable tensioning (“A” port is

checked internally, can only be released by building pressure in “B” position).

3. Valve is placed in “B” position, which is pressure controlled and will not exceed 6,400 psi. “Return” portion of stressing tool is pressurized and will release “A” port when pressure reaches approximately one-half the “A” port pressure. “A” port remains open as long as this pressure differential is maintained.
4. Pump is stopped, valve is placed in “A” position, releasing “B” port

pressure.

Used on these pumps: PA17*, PA46*, PA55, PE17*, PE21*, PE30, PE46*, PE55, PE60, PE84, PE120, PE200, PE400, PG30*, PG55, PG120, PG400, PQ60 and PQ120 series.

* These pumps may have reduced first flow stage characteristics due to internal valve restrictions.

No. 9628 – Post tensioning valve for 10,000 psi (max.) single-acting/Power Wedge seater. Wt., 5.4 lbs.

“TWIN” 4-WAY/3-POSITION (TANDEM CENTER) MANUAL VALVE

Application – Multi-strand, double-acting stressing jacks with an auxiliary seating cylinder.

Actuation – Dual lever operated, detent positioned.

Operation –

1. With valves “A” and “B” in center position, pump is started; cable is inserted into stressing tool.
2. Valve “A” is placed in “Stress” position; cylinder extends to tension cable. Pump pressure controls force exerted by tensioning cylinder in this position. “Stress” port is checked internally, and can only be released by building pressure in the valve “B” return position.
3. When desired cable tension is achieved, valve “A” is placed in valve “B” position and valve “B” in “Seat” position. Seating portion of cylinder

will be pressurized to seating pressure controlled by “Seat” relief valve (factory set to 3,900 psi).

4. Valve “B” is shifted to “Return” position, which is pressure controlled and will not exceed 2,200 psi. “Return” portion of stressing tool should be pressurized and will release “Stress” port when pressure reaches 15% of “Stress” port pressure.
5. “Stress” port will remain open and cylinder will return as long as pressure differential is maintained. “Stress” and “Seat” ports are open to reservoir.
6. When cylinder has fully returned, both valves are shifted to “Center” position and oil will be directed to reservoir. Maximum pressure setting for the “Seat” relief valve is 6,000 psi.

Used on these pumps: PA17*, PA46*, PA55, PE17*, PE21*, PE30, PE46*, PE55, PE84, PE120, PE200, PE400, PG30*, PG55, PG120, PG400, PQ60

and PQ120 series.*

* These pumps may have reduced first flow stage characteristics due to internal valve restrictions.

No. 9632 – Post tensioning valve for 10,000 psi (max.) double-acting systems. Wt., 13.6 lbs.

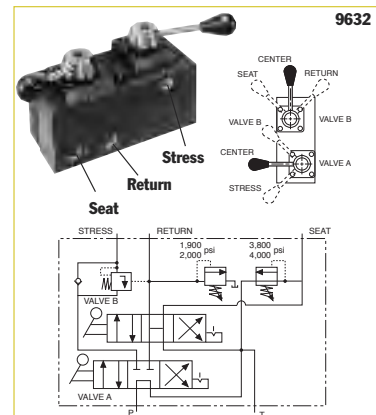

9632

Pump mounted, 6-position detented 5-way manual dual valve. Rated pressure to valve “A” is 10,000 psi and valve “B” is 6,000 psi. Case pressure is 500 psi max.

CAUTION: To prevent sudden, uncontrolled descent of a load as it is being lowered, use a No. 9596 Load Lowering Valve or No. 9720 Counter Balance Valve (see page 118) in conjunction with the directional valve used in your application.

IMPORTANT: Conversion kit 251528 must be used when mounting any of the valves on this page on PA17 or PE17 pumps.

IMPORTANT: When ordering any valve for a PE30 or PG30 series pump, 1/2" longer mounting screws are required. For valves 9569, 9570 and 9579, order four 10856 cap screws. For valves 9552, 9572 and 9592, order four 12001 cap screws.

ACCESSORIES



HYDRAULIC PUMP

Accessories



ACCESSORIES

25017
202777
202778
304718



203225



10461

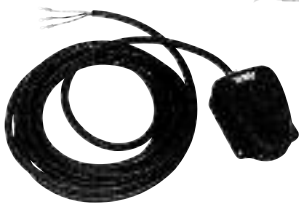

251660



309652
309653



17627
216209



ON/OFF MOTOR CONTROL

The following remote control switches will give you momentary "ON" control of your hydraulic pump. These switches are deadman type, spring loaded to the "OFF" position. They can be used with any Power Team electric hydraulic pumps.

No. 25017 – Remote hand control. Has a push button switch, with a 10 foot cord. Wt., 0.8 lb.

No. 203225 – Remote hand control. Heavy-duty with single push button switch in a neoprene housing with 10 foot cord. Housing seals out dust, lint and liquids (unit is not submersible). Wt., 0.8 lb.

No. 10461 – Remote foot control, with 10 foot cord. Wt., 3 lbs.

No. 251660 – Remote foot control, with 10 foot cord. For use with the PE10 style pumps. Wt., 1 lb.

SOLENOID & MOTOR CONTROL

For use on solenoid valves that are used on single-acting cylinders:

No. 202777 – Remote hand control. Has rocker style switch that is momentary advance, spring center hold and detented retract. It comes with a 10 foot cord, for use with 3-way/2 or 3-position valves. Wt., 0.9 lb.

For use on solenoid valves that are used on double-acting cylinders:

No. 202778 – Remote hand control. Has rocker style switch that is momentary advance, spring center hold and momentary retract. It comes with a 10 foot cord, for use with 4-way/3-position valves. Wt., 0.9 lb.

No. 309653 – Remote foot control. Can be used in place of either of the above hand controls to control the same type of valves. The switch is momentary on both the advance and retract position and is spring centered to the hold position. This foot switch comes with 10 foot cord. Wt., 4 lbs.

No. 17627 – Remote foot control. Same as the No. 309653 but without a cord. Wt., 2 lbs.

No. 304718 – Remote hand control. Has a rocker style switch that is momentary advance, spring center hold and momentary retract. The switch is wired to start and stop the motor when the valve is energized. It comes with a 10 foot cord. To be used with 4-way/2-position valves. Wt., 0.9 lb.

No. 309652 – Remote foot control. Has same functions as No. 304718. Supplied with a 10 foot cord. To be used with 4-way/2-position valves. Wt., 4 lbs.

No. 216209 – Remote foot control. Same as the No. 309652, but without a cord. Wt., 2 lbs.

NOTE: See valves listing to determine which remote to use.
Page 122-129.

REMOTE AIR MOTOR CONTROLS

This remote hand control has two momentary push buttons, one for advance and one for retract with spring offset to hold. To be used with 4-way/2-position air pilot valves.

No. 209593 – Remote hand control with 12 foot cord. Wt., 2 lbs.

SUBPLATES

For remote mounting of control valves. They convert pump mounted valves to remote mounted valves quickly and easily.

No. 9510 – Subplate for remote mounting the following valves; 9500, 9501, 9502, 9504, 9506, 9507, 9511, 9552, 9572, 9575, 9576, 9592, 9594 and 9609. Wt., 1.5 lbs.

No. 9620 – For use with 9500, 9501, 9502, 9552, 9572, 9592 and 9594. Same as No. 9510 but has integral pressure regulating valve. Wt., 3.8 lbs.

PUMP-MOUNTED SUBPLATES

No. 9515 – Subplate, Wt., 1.3 lbs.

When fitted between pump cover plate valve mounting flange and control valve, provides a separate $\frac{3}{8}$ " NPTF female port, open to "return" regardless of position of valve. Also provides a separate $\frac{3}{8}$ " NPTF female pressure port. This subplate can be useful when you desire to use one pump with a deck-mounted control valve, plus a separate remote-mounted valve to control another function.

For use with the following valves: 9500, 9501, 9502, 9504, 9506, 9507, 9511, 9520, 9552, 9572, 9575, 9576, 9592, 9594, and 9609.

No. 9521 – Subplate for use under most pump mounted valves to provide adjustable pressure control on units not equipped with an external pressure regulator. Wt., 3.8 lbs.

AIR FILTER/REGULATOR/LUBRICATOR

Recommended for use with single-speed air/hydraulic pumps found on pages 49-67.

No. 9531 – Filter/regulator. $\frac{1}{4}$ " NPTF inlet and outlet. Wt., 0.8 lb.

PRESSURE SWITCH

Application: Used in a hydraulic circuit where system pressure must be "held". Automatically (electrically) turns off pump motor when predetermined system pressure is reached.

Attaches directly to control valve manifold or can be mounted "in-line" to read system pressure. Has a $\frac{1}{4}$ " NPTF male thread, and a $\frac{1}{4}$ " NPTF fitting for gauge mounting if required. Adjustable from 1,000 to 10,000 psi. Can also be used to actuate other electrical devices in the system. Wired "normally open" and held closed by spring pressure.

IMPORTANT: Electrical rating of switch is 5 amps at 250 volts max. To prevent permanent damage to switch, a control relay must be installed to handle currents or voltage exceeding these limits. Pressure switch should never be used to directly actuate the electrical motor.

No. 9625 – In-line pressure switch with $\frac{1}{4}$ " NPTF gauge port. Wt., 1.1 lbs.

PILOT OPERATED AIR CONTROL VALVES

Application: For use when an air pilot signal is required at a set hydraulic pressure. Can be used to shift valves, and start or stop pneumatic pumps.

Attaches directly to control manifold or can be mounted "in-line" to read system hydraulic pressure. Automatically turns on an air pilot signal when a predetermined system pressure is reached. Has $\frac{1}{4}$ " NPTF male thread and $\frac{1}{4}$ " NPTF fitting for gauge mounting if required. Adjustable from 500-10,000 psi. Maximum rating of 25 scfm at 100 psi.

No. 9641 – Pilot operated control valve, normally closed, with $\frac{1}{4}$ " NPTF male thread. Wt., 1 lb.

No. 9643 – Same as 9641 except normally open. Wt., 1 lb.

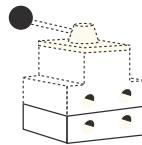

9510 and 9620 attach to the bottom of valve for remote mounting. The 9515 and 9521 mount between the pump cover plate and valve.

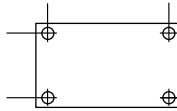

9510

9515



9620



9521

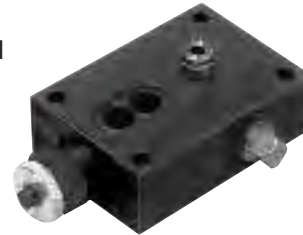

9531



9625

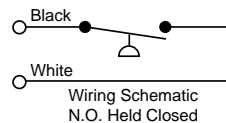

Air In

Air Out

9641

9643

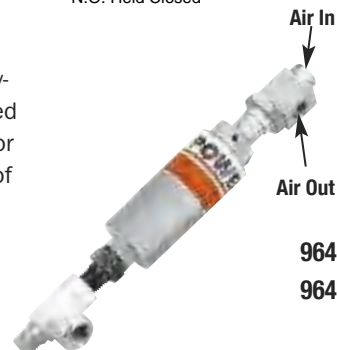

ACCESSORIES



HYDRAULIC PUMP ACCESSORIES

252511
252512



206767
250175



350431



10494

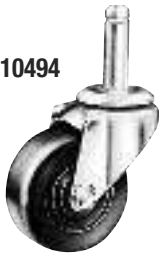

207762



16339



OIL COOLER KITS

No. 252511 – Oil cooler kit designed for use with PE604T or PE604PT pumps with 115 VAC. Wt., 5 lbs.

No. 252512 – Oil cooler kit designed for use with PE604T or PE604PT pumps with 220 VAC. Wt., 5 lbs.

RESERVOIR BREATHER KITS

No. 206767 – Reservoir breather kit designed for use on PA17, PA55, PE17, PE55, PE84, PE90, PE120, PG55, PG120, PQ60 and PQ120 series pumps. Wt., 1.3 lbs.

No. 250175 – Reservoir breather kit designed for use on PE21 and PE46 series pumps. These kits replace the reservoir filler cap when the pump is used in dusty and dirty environments. Wt., 1.3 lbs.

CASTERS

2" diameter casters attach to the bottom of large reservoir for portability.

Sold individually; order the amount you need.

No. 10494 – Single caster wheel. Wt., 0.3 lb.

FLUID LEVEL/TEMPERATURE GAUGE

Displays fluid level and temperature of hydraulic oil in reservoir.

32°-212°F, 0°-100°C. 1¹/₄" wide and 6³/₈" high.

No. 350431 – Fluid level/temperature gauge.

FOOT CONTROL GUARD

Guard for use with 10461 and 251660 foot controls.

No. 16339 – Wt., 4.5 lbs.

MAGNETIC STRIP

Magnetic strip with adhesive back can be added to No. 25017, 202777, 202778 and 304718 hand controls. Provides 6 lbs. of holding force.

No. 207762 – Wt., 0.1 lb.

VITON® SEAL KITS

(SEE PAGE 33)



Viton* seal kits

Order Number	Use With	Model
300507	P12	All
300472	P23, P55	All
300510	P59	All
300508	P157, P159, P300	A
300690	P157, P159	B
300696	P300	B
300508	P157D, P159D, P300D	A
300693	P157D, P159D	B
300699	P300D	B

VITON® SEAL KITS Can be used in all "C" and "RH" series cylinders (see pages 14-15 and 20-21), as well as the P12, P55, P59, P157/P159, P157D/P159D and P300/P300D series of hand pumps. These seals are required when fire resistant hydraulic fluids are used. Not required with Flame-Out fluid.

* Viton is an E.I. duPont De Nemours & Co., Inc, trade name.

UNIVERSAL PUMP CART

Mobilize your hydraulic pumps with the PC200. The rugged tubular frame can easily handle pumps weighing up to 200 lbs. With 12" wheels, the cart rolls easily. Just load the pump onto the cart and wheel it right to the job. The universal mounting hole pattern lets you handle a wide variety of Power Team pumps.

No. PC200 – Universal pump cart with 12" wheels. Cart can be used with the following pumps: PA60, PA64 and PA554 air/hydraulic pumps; PE55 series, PE183-2 and PE184-2 electric/hydraulic pumps; PE21, PQ60 and PQ120 series "Quiet" pumps; PG55 series gas engine/hydraulic pumps; and pumps with optional 5- and 10-gallon reservoirs; Nos. RP50, RP51, RP101 and RP103. Wt., 27 (Shown with pump, pump not included)

PROTECTIVE PUMP ROLL CAGE

Safeguards pump, gas engine and valves on the job site. Horizontal bars provide convenient hand holds for carrying pump, a pick-up point permits lifting unit with an overhead crane or other device. Standard equipment on PG1203 and PG1204. Can be ordered as an option with any other gas, air, or electrically driven hydraulic pump equipped with a 5-gallon reservoir.

Note: Refer to PG1203/PG1204 specification chart (pp 96-97) for dimensions of roll cage.

No. PC200RC – Roll cage for use with PC200. (Cannot be used on pumps with 10 gallon reservoirs.) Wt., 36 lbs.

No. RC5 – Roll cage. Wt., 19.5 lbs for PG55 & PG120. For use with PG120 and PG 55 series pumps

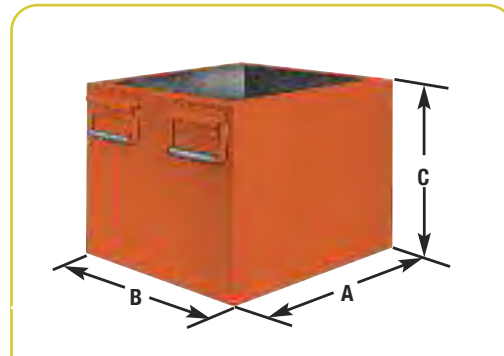

LARGE CAPACITY RESERVOIRS

Capacity (gal.)	Order Number	Usable Oil (cu. in.)	Use With	Size (in.)		
				A	B	C
2	RP20**	442	PA6, PA50 series (models A-E)	11 ¹ / ₂	9 ¹ / ₂	6 ¹ / ₂
2	RP20-F**	442	PA6 series (model F), PA 50 series (model F & G)	11 ¹ / ₂	9 ¹ / ₂	6 ¹ / ₂
2 ¹ / ₂	RP20M*	450	PA6, PA50 series (models A-E)	11 ¹ / ₂	9 ¹ / ₂	6 ¹ / ₂
2 ¹ / ₂	RP20M-F*	450	PA6 series (model F), PA50 series (model F & G)	11 ¹ / ₂	9 ¹ / ₂	6 ¹ / ₂
2 ¹ / ₂	RP21*	450	PE18 series	11 ¹ / ₂	9 ¹ / ₂	6 ¹ / ₂
2 ¹ / ₂	RP22†	442	PE55, PE90, PE120, PA55	11 ¹ / ₂	9 ¹ / ₂	6 ¹ / ₂
5	RP50	1150	PE55, PE90, PE120, PA55	18	12 ¹ / ₂	8 ¹ / ₂
5	RP51	1150	PA46, PE46, PE21	18	12 ¹ / ₂	8 ¹ / ₂
10	RP100	2194	PE55, PE90, PE120, PA55	18	12 ¹ / ₂	14 ¹ / ₂
10	RP101	2194	PG55, PG120	18	12 ¹ / ₂	14 ¹ / ₂
10	RP103*	2310	PQ60, PQ120	15 ⁷ / ₁₆	14 ¹ / ₄	12 ⁵ / ₁₆
10	RP104	2194	PA46, PE46, PE21	18	12 ¹ / ₂	14

* Four mounting holes: 1/2"-20, for 2" diameter swivel casters (No. 10494)
 ** High density polyethylene reservoir. † Aluminum reservoir.

NOTE: All metal reservoirs are equipped with drain plugs and all necessary conversion items. Hydraulic oil is not included with reservoir kits. Please order separately. See page 112.

METAL RESERVOIR CONVERSION KITS FOR PUMPS *INCLUDES GASKETS AND FASTENERS.

Pump Number	Metal Reservoir Order Number	Metal Reservoir Capacity	Reservoir Weight (lbs.)	Pump Number	Metal Reservoir Order Number	Metal Reservoir Capacity	Reservoir Weight (lbs.)	Pump Number	Metal Reservoir Order Number	Metal Reservoir Capacity	Reservoir Weight (lbs.)
PA6	213896	105 cu. in.	3	PA50	213896	105 cu. in.	3	PA174	213895	578 cu. in.	9
PA6A	213896	105 cu. in.	3	PA50R	213896	105 cu. in.	3	PE172	213895	578 cu. in.	9
PA6D	213896	105 cu. in.	3	PA6R	213896	105 cu. in.	3	PE172A	213895	578 cu. in.	9
PA6-2	213895	578 cu. in.	9	PA50R2	213895	578 cu. in.	9	PE172S	213895	578 cu. in.	9
PA6D2	213895	578 cu. in.	9	PA172	213895	578 cu. in.	9	PE174	213895	578 cu. in.	9

ACCESSORIES



SHOP EQUIPMENT

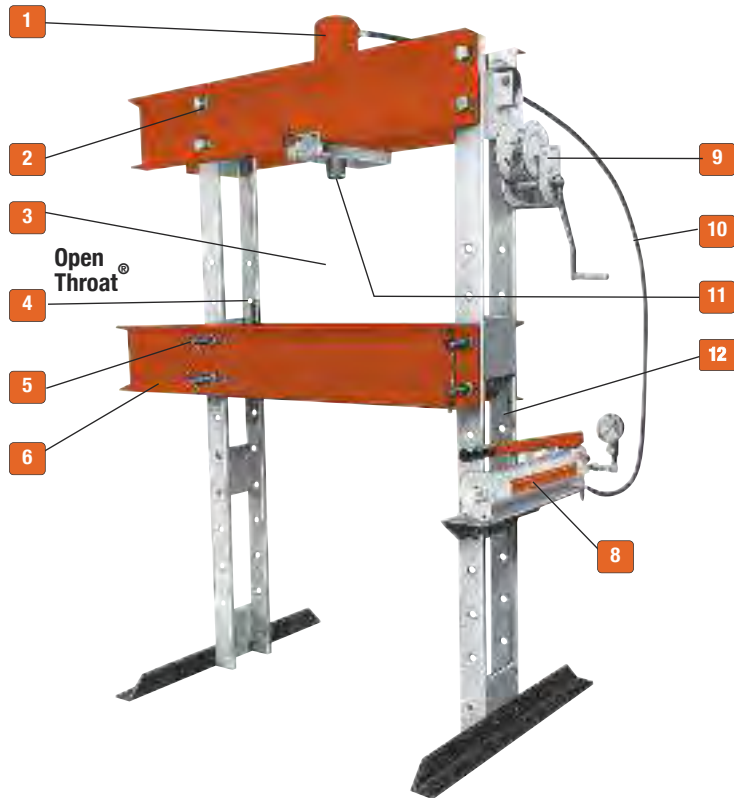

THE UNIQUE BENEFITS OF THE POWER TEAM PRESS

1 2 TO 1 SAFETY FACTOR on hydraulic cylinders and they meet ASME B30.1 standards. Cylinders are easily removed for other applications. Single- or double-acting cylinders are available; built-in relief valve on double-acting cylinders.

2 FULL RATED CAPACITY across width of upper frame, even with workhead moved to one side. (Heavy-duty presses only.)

3 LARGER WORK AREA than most competitors' models.

4 ALIGNMENT LEVER for simple pin replacement after raising or lowering the bed.

5 CLOSE MANUFACTURING TOLERANCE allows even load distribution over four alloy steel pins; not two, like some competitors. (Heavy-duty presses only.)

6 OPEN THROAT® FEATURE on 25 ton press provides additional work area by

mounting cylinder on outside for C-frame advantage.

7 FRAMES CAN BE USED HORIZONTALLY for pressing jobs on extra-long shafts (see photo on next page).

8 ELECTRIC, AIR OR HAND HYDRAULIC PUMPS are available. All are standard Power Team pumps.

CSA approved electric pumps are standard on all presses. Externally adjustable relief valve for precise operator control of working pressure

is standard on all electric pumps except PE10 and PE17 series.

24 volt hand switch for remote control on pumps equipped with solenoid valves.

9 ONE-MAN OPERATION for bed adjustment. Winch unit quickly raises or lowers bed to desired height. Self-locking winch mechanism prevents bed from dropping when handle is released.



Horizontal pressing capabilities

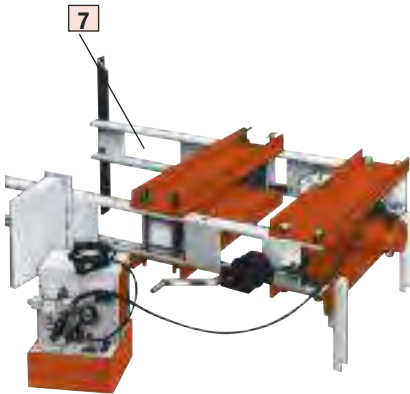

Page
C FRAME ...136

Page
H FRAME ...137
25-55 TON

Page
H FRAME ...140
100-200 TON

Page
H FRAME ...142
80-200 TON
ROLL BED

Page
ACCESSORIES ...144



Page
FLOOR CRANES ...146



Page
LOAD-ROTORS® ...147

10 3/8" I.D. HOSE on spring return cylinders on heavy-duty presses provides up to six times faster cylinder return than standard 1/4" I.D. hose.

11 FAST CYLINDER APPROACH to work provided by 2-speed hand, air or electric pumps.

12 RUGGED UPRIGHTS, 50 percent stronger than channel iron. Four post design means open side for easy loading of long material.

NOTE: Certain features do not apply to Power Team 10 ton, Roll-Bed, or economy presses.

NOTE: Certain press applications may require guarding. Because of the multitude of possible press uses, it is impossible to design a guard that will meet every customer need. The end user must provide their own guarding where the situations dictate.

IMPORTANT SAFETY INFORMATION:

Power Team has protective blankets available which may afford protection from injury to users and others should part breakage occur. Power Team recommends the use of these blankets for all pushing, pulling, pressing, and lifting applications. See page 209 for additional information.

SHOP PRESS

C Frame
25 Tons Press

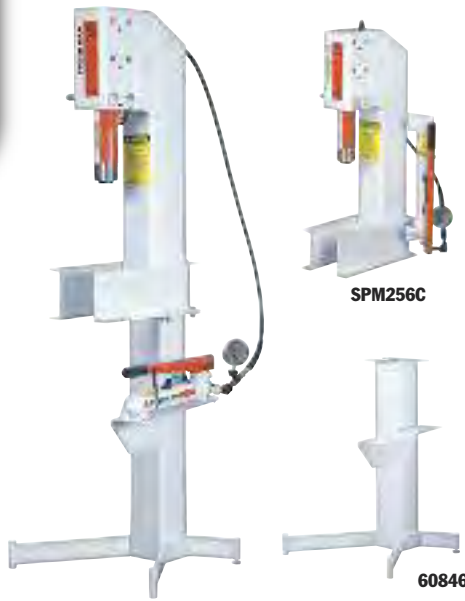

- Can be bench mounted or on optional pedestal base.
- Bench mount requires less than 1.5 sq. ft. of space; on optional pedestal, only 4 sq. ft. of floor space is needed.
- “Open Throat” design makes loading and unloading of work easy.
- Cylinder head adjusts to three convenient working positions, providing up to 20¹/₄” of “daylight.”
- Hydraulic cylinder delivers a 6¹/₄” stroke, is driven by a P59 two-speed hand pump.

Pedestal Base No. 60846 – Provides a stable base for SPM256C. Includes a bracket for mounting the pump on the side of pedestal press. Wt., 76 lbs.

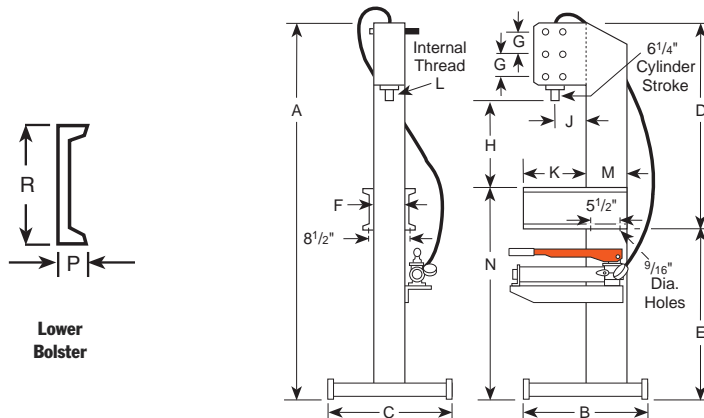

DIMENSIONS

A	B	C	D	E	F	G	H (Cyl. Retracted)	J	K	L	M	N	P	R	Floor Space
(in)	(in.)	(in.)	(in.)	(in.)	(in.)	(in.)	(in.)	(in.)	(in.)	(in.)	(in.)	(in.)	(in.)	(in.)	(in.)
77 ⁵ / ₈	24 ¹ / ₂	24	41 ⁵ / ₈	36	6	5	10 ³ / ₄ , 15 ¹ / ₄ , 20 ¹ / ₄	6 ¹ / ₂	12 ¹ / ₂	1 ¹ / ₂ – 16	8	43	2	7	24 x 24 ¹ / ₂

ORDERING INFORMATION

Capacity (tons)	Type Cyl. Used	Stroke	Cyl. Model	Order No.	Speed** Advance	Pressing	Type Pump	Pump Model	Prod.Wt. (lbs.)
25	Single-Acting	6 ¹ / ₄ ”	C256C	SPM256C*	.129 in./stroke	.03 in./stroke	Hand	P59	240
25	Single-Acting	6 ¹ / ₄ ”	C256C	SPX256C*	.129 in./stroke	.03 in./stroke	—	—	240

* SPM256C does not include No. 60846 pedestal base. Pump not included.

** Typical performance based on pump specifications. Actual speeds may vary with operating conditions.

SHOP PRESS

H Frame

10 Tons Bench/Floor Press

- Ideal for small pressing jobs; repairing small motors, armatures, removing and installing gears, bearings, other press-fit parts.
- Bench press has 15³/₈" x 18" work area; floor press bed height is adjustable from 5" to 41" with horizontal "daylight" of 21".
- Choices of power sources: single-speed hand pump, electric/hydraulic or air/hydraulic.
- Hydraulic gauges, hoses and fittings included.

PUMP ELECTRICAL SPECIFICATIONS

PE10 Series – 1/4 hp, 115 volt, 60 cycle, single phase. Also available in 230 volt, 50 cycle, add suffix "-220" to order number.



SP1010A



SPM1010

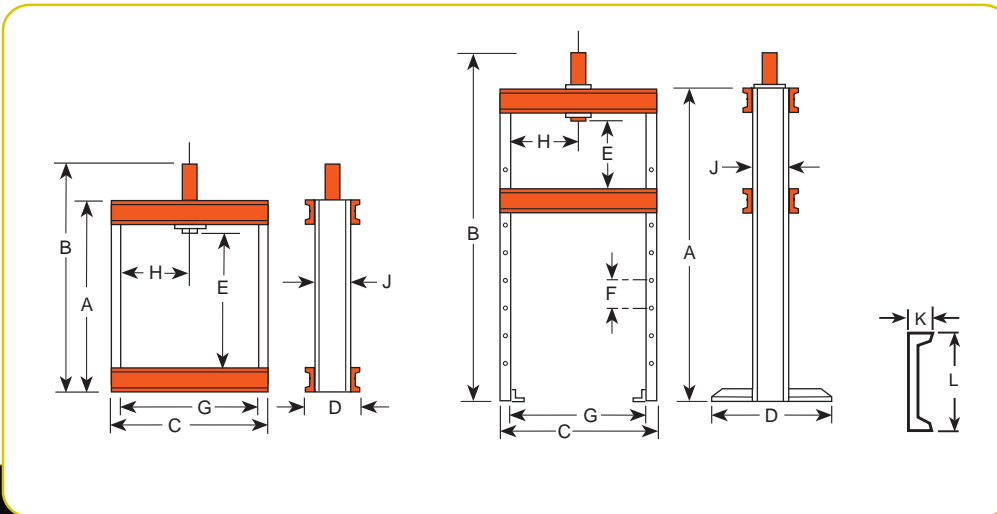

DIMENSIONS

Frame	A (in)	B (in.)	C (in.)	D (in.)	E (in.)	F (in.)	G (in.)	H (in.)	J (in.)	K (in.)	L (in.)	Bench Space (in.)	Floor Space (in.)
Bench	24 ¹ / ₂	33 ¹ / ₈	25 ¹ / ₄	7 ³ / ₁₆	15 ³ / ₈	—	22	11	4	1 ⁹ / ₁₆	4	7 ³ / ₁₆ X 25 ¹ / ₄	—
Floor	59	67 ⁵ / ₈	25 ¹ / ₄	28	5-41	6	22	2 ¹ / ₂ -18 ¹ / ₂ *	4	1 ⁹ / ₁₆	4	—	28 x 28 ¹ / ₄

*Lateral head movement

ORDERING INFORMATION

Frame	Cap. (tons)	Type of Cyl. Used	Stroke	Cylinder Model	Order No.	Speed (in./min.) ^{†††}	Type Pump	Pump Model [†]	Prod. Wt. (lbs.)
						Advance Pressing			
222481 Bench	10	Single-Acting	10 ¹ / ₈ "	C1010C	SPM1010	.06 in./stroke	Hand	P55	91
222480 Floor	10	Single-Acting	10 ¹ / ₈ "	C1010C	SPH1010	.06 in./stroke	Hand	P55	171
222480 Floor	10	Single-Acting	10 ¹ / ₈ "	C1010C	SPE1010	0.2 2.2	Elec. ††	PE102	175
222480 Floor	10	Single-Acting	10 ¹ / ₈ "	C1010C	SP1010A	0.3 3.7	Air	PA9H	162
222480 Floor	10	Double-Acting	10"	RD1010	SPE1010D	0.2 2.2	Elec. ††	PE104	192

† Optional air/hydraulic pumps available on request.

†† "Advance" position holds pressure with motor shut off. "Return" position advances cylinder with motor running and returns cylinder with motor shut off.

††† Typical performance based on 100 psi and 10,000 psi pump specifications. Actual speeds may vary with operating conditions.

PRESS

H Frame

Open Throat & Economy Press 25 Ton Presses



Hydraulic gauge and hydraulic fittings are included with presses.

OPEN THROAT PRESSES

- Design permits use as both "H" frame and "C" frame press; cylinder can be mounted on frame extension to handle jobs which won't fit between uprights.
- Open throat press models are also available with remote control to enable the operator to view work from all sides with fingertip control of cylinder piston travel.
- Off-center pressing loads of full capacity can be applied across entire width of frame.

ECONOMY PRESSES

- Rugged, yet reasonably priced. Handles many "big press" tasks, and perfect for many of the "in-between" jobs you see almost daily. (Note: stroke length limited to 6¹/₄" on economy models.)

FEATURES OF BOTH OPEN THROAT AND ECONOMY PRESSES

- Press bed height easily adjustable with winch. Bed will not drop when handle is released.
- Choice of power sources for rapid cylinder advance: two-speed hydraulic hand pump, electric/hydraulic or air/hydraulic.

PUMP ELECTRICAL SPECIFICATIONS

PE17 Series – 1/2 hp, 115 volt, 60 cycle, single phase.

PE21 Series – 1 hp, 115 volt, 60 cycle, single phase. Both pumps available in 230 volt, 50 cycle, add suffix "-220" to order no.

Open Throat feature enables cylinder to be mounted on outside of press frame for fast bearing removal and more.

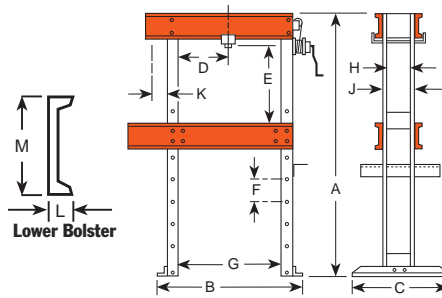

DIMENSIONS

A (in.)	B (in.)	C (in.)	D* (in.)	E (in.)	F (in.)	G (in.)	H (in.)	J (in.)	K (in.)	L (in.)	M (in.)	Floor Space (in.)
68	43	28	3 - 29	6 ⁷ / ₈ - 43 ³ / ₈	4 ¹ / ₂	32	5 ¹ / ₂	6 ¹ / ₂	7	2 ¹ / ₂	8	43 x 28

*Lateral head movement

ORDERING INFORMATION

Cap. (tons)	Type of Cylinder Used	Stroke	Cylinder Model	Order No.	Speed (in./min.)††† Advance	Pressing	Type Pump	Valve Type	Pump‡ Model	Prod.Wt. (lbs.)
"Open Throat" presses										
25	Single-Acting	14 ¹ / ₄ "	C2514C	SPA2514	9.8	1.2	Air	2-Way Foot	PA6	683
25	Single-Acting	14 ¹ / ₄ "	C2514C	SPM2514	.49	.03	Hand	Load-Release	P159	693
25	Single-Acting	14 ¹ / ₄ "	C2514C	SPE2514	46.6	3.3	Elec.	2-Way††	PE172	665
25	Single-Acting	14 ¹ / ₄ "	C2514C	SPE2514S	52	4.0	Elec.	3-Way†	PE213S	759
25	Double-Acting	14 ¹ / ₄ "	RD2514	SPE2514DS	52	4.0	Elec.	4-Way†	PE214S	787
"Economy" presses										
25	Single-Acting	6 ¹ / ₄ "	C256C	SPA256	9.8	1.2	Air	2-Way Foot	PA6	578
25	Single-Acting	6 ¹ / ₄ "	C256C	SPM256	.129	.129	Hand	Load-Release	P59	595
25	Single-Acting	6 ¹ / ₄ "	C256C	SPE256	46.6	3.3	Elec.	2-Way††	PE172	607

† Solenoid valve with 24 volt remote control hand switch.

†† Holds pressure with motor shut off. Also has an automatic dump setting. Furnished with a 10' remote motor control.

††† Typical performance based on 100 psi and 10,000 psi pump specifications. Actual speeds may vary under operating conditions.

‡ Pump standard with press. Other Power Team pumps can be substituted. dBA at idle and 10,000 psi: PE172-67/81 dBA; PE21-70 dBA measured at 3 foot distance, all sides.

PRESS

H Frame 55 Ton Presses

- Full off-center pressing at full rated capacity across width of upper frame without buckling or bending.
- Maximum “daylight” is 42" x 36", making positioning of even bulky work pieces easy.
- Height of press bed is easily adjusted with winch; friction brake prevents bed from dropping and handle from spinning upon release.
- Presses with single-acting cylinder offer choice of 2-speed hand operated, electric/hydraulic, or air/hydraulic pump. Models with double-acting cylinder have an electric/hydraulic pump.
- Press models equipped with remote control enable operator to view work from all sides with fingertip control of cylinder piston travel.
- Press can be used horizontally for special applications with user-supplied support legs.



Hydraulic gauge and hydraulic fittings are included with presses.

PUMP ELECTRICAL SPECIFICATIONS

PE17 Series – 1/2 hp, 115 volt, 60 cycle, single phase. Also available in 230 volt, 50 cycle.

PE21 Series – 1 hp, 115 volt, 60 cycle, single phase. Also available in 230 volt, 50 cycle.

PQ60 Series – 2 hp, 230 volt, 60 cycle, single phase. Also available in 230 volt, 50 cycle. To order presses with 230 volt, 50 cycle pumps, add suffix “-220” to order no.



No. SF50 – Straightening fixtures for use with 55-ton shop or 80-ton Roll-Bed® presses (2 ea.). Wt., 104 lbs. **Not part of press, order separately.**

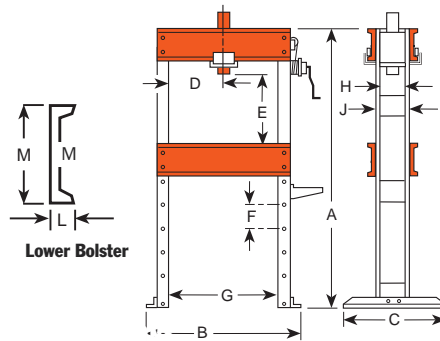

A (in.)	B (in.)	C (in.)	D* (in.)	E (in.)	F (in.)	G (in.)	H (in.)	J (in.)	L (in.)	M (in.)	Floor Space (in.)
72	48½	36	3¼-32¾	6 - 42	6	36	6¾	8	3	12	48½ x 36

*Lateral head movement

ORDERING INFORMATION

Cap. (tons)	Type of Cylinder Used	Stroke	Cylinder Model	Order No.	Speed (in./min.)†††	Type Pump	Valve Type	Pump‡ Model	Prod.Wt. (lbs.)
55	Single-Acting	6¾"	C556C	SPA556	4.5	Air	2-Way Foot	PA6	804
55	Single-Acting	6¾"	C556C	SPM556	.23	Hand	Load-Release	P159	814
					in./stroke				
55	Single-Acting	13¾"	C5513C	SPM5513	.665	Hand	2-Way	P460	960
					in./stroke				
55	Single-Acting	6¾"	C556C	SPE556	21.7	Elec.	2-Way††	PE172	836
55	Single-Acting	13¾"	C5513C	SPE5513	21.7	Elec.	2-Way††	PE172	980
55	Single-Acting	13¾"	C5513C	SPE5513S	24.4	Elec.	3-Way†	PE213S	1,056
55	Double-Acting	13¾"	RD5513	SPE5513D	21.7	Elec.	4-Way	PE174	993
55	Double-Acting	13¾"	RD5513	SPE5513DS	66.1	Elec.	4-Way†	PQ604S	1,114

* Frame is shipped assembled.

† Solenoid valve with 24 volt remote control hand switch.

†† Holds pressure with motor shut off. Also has an automatic dump setting. Furnished with a 10' remote motor control.

††† Typical performance based on 100 psi and 10,000 psi pump specifications. Actual speeds may vary with operating conditions.

‡ Pump standard with press. Other Power Team pumps can be substituted. dBA at idle and 10,000 psi: PE172—67/81; PE21 Series—70; PQ60—74/76; measured at 3 foot distance, all sides.



H FRAME PRESSES

100 Ton Presses

- Cylinder workhead glides across upper frame on rollers, locks in place for off-center pressing jobs. May be used horizontally for special pressing applications with user-supplied supports.
- Press bed is raised and lowered by winch which locks in place for insertion of bed retaining pins. Upper bolster can be lowered 8" for convenient positioning on repetitive jobs.
- Generous "daylight" of 42" x 50" accommodates bulky work pieces, uprights are placed for easy side entry of bars or shafts for straightening or bending.
- Choice of single- or double-acting cylinder. Hydraulic pump options include: 2-speed hand pump with large 2-gallon reservoir, PE172 electric/hydraulic pump or "PQ" series "Quiet" electric/hydraulic pump with low noise level.



Hydraulic gauge and hydraulic fittings are included with presses.



No. SF150 – Straightening fixtures for use with 100-ton shop press and 100-, 150-, and 200-ton Roll-Bed® presses (2 ea.). Wt., 196 lbs. **Not part of press, order separately.**

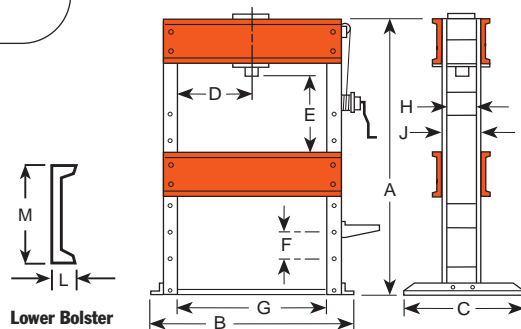

PUMP ELECTRICAL SPECIFICATIONS

PE17 Series – 1/2 hp, 115 volt, 60 cycle, single phase. Also available in 230 volt, 50 cycle, add suffix "-220" to order no.

PQ60 Series – 2 hp, 230 volt, 60 cycle, single phase. Available in 115 volt, 60 cycle and 230 volt, 50 cycle. To order 230 volt, 50 cycle, add suffix "-220" to order no. For 115 volt consult factory.

PQ120 Series – 3 hp, 460 volt, 60 cycle, three phase. Available in 220/380 volt, 50 cycle. To order 380 volt, 50 cycle, add suffix "-380" to order no.

DIMENSIONS

A (in.)	B (in.)	C (in.)	D* (in.)	E (in.)	F (in.)	G (in.)	H (in.)	J (in.)	L (in.)	M (in.)	Floor Space (in.)
77 ¹ / ₄	64	36	7 - 43	2 - 42	8	50	8	10	3 ³ / ₈	15	36 x 78 ¹ / ₄

*Lateral head movement

ORDERING INFORMATION

Cap. (tons)†	Type of Cyl. Used	Stroke	Cylinder Model	Order No.	Speed (in./min.)†† Advance in./stroke	Pressing in./stroke	Type Pump	Valve Type	Pump‡ Model	Prod. Wt. (lbs.)
100	Single-Acting	10 ³ / ₄ "	C10010C	SPM10010	.356	.01	Hand	3-way	P460	1,698
100	Single-Acting	10 ³ / ₄ "	C10010C	SPE10010	35	2.9	Elec.	3-way	PQ603	1,795
100	Single-Acting	10 ³ / ₄ "	C10010C	SPE10010R	11.5	.8	Elec.	2-way	PE172	1,690
100	Double-Acting	13 ³ / ₈ "	RD10013	SPE10013DS	35	5.8	Elec.	4-way*	PQ1204S	1,886

† Frame is shipped assembled. *Solenoid valve with 24 volt remote control hand switch.
 †† Typical performance based on 100 psi and 10,000 psi pump specifications. Actual speeds may vary under operating conditions.
 ‡ Pump standard with press. Other Power Team pumps can be substituted.
 dBA at idle and 10,000 psi: PE172—67/81; PQ60—74/76; PQ120—73/78. Measured at 3 foot distance, all sides.

H FRAME PRESSES

150-200 Ton Presses

- Standing 7½-feet tall, these giants handle the really big jobs. May be used horizontally for special pressing applications with user-supplied supports.
- Workhead has wide horizontal travel; rugged press frame withstands load of rated capacity across full width of frame.
- Winch mechanism provides easy positioning of press bed, locks in place for insertion of retaining pins. Upper bolster can be lowered 11" for convenient positioning on repetitive jobs.
- Uprights are placed for easy entry of bars or shafts for straightening or bending.
- Fast cylinder approach is provided by PQ1204S "Quiet" electric/hydraulic pump. Has remote control hand switch, enabling operator to view work from all sides with fingertip control of cylinder piston travel.



Hydraulic gauge and hydraulic fittings are included with presses.

PUMP ELECTRICAL SPECIFICATIONS

PQ120 Series – 3 hp, 460 volt, 60 cycle, three phase. Also available in 220/380 volt, 50 cycle, add suffix "-380" to order no.

NOTE: To order press with 230 volt, 60 cycle, single phase pump, order press less PQ1204S. Order pump No. PQ604S separately.

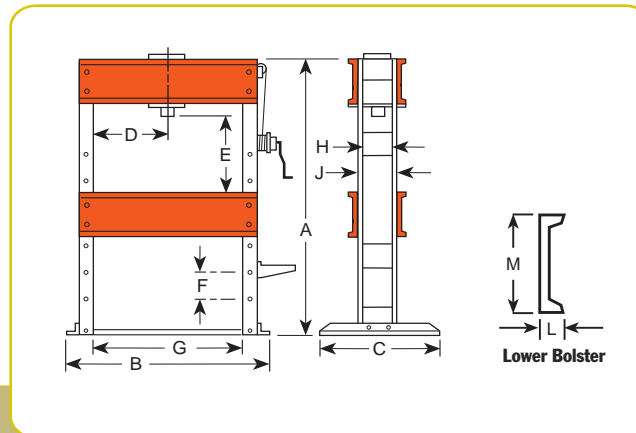

DIMENSIONS

A (in.)	B (in.)	C (in.)	D* (in.)	E (in.)	F (in.)	G (in.)	H (in.)	J (in.)	L (in.)	M (in.)	Floor Space (in.)
90	71	44	11 - 39	9 - 43¾	11	50	12½	15	4⅞	18	44 x 71

*Lateral head movement

ORDERING INFORMATION

Capacity (tons)†	Type of Cylinder Used	Stroke	Cylinder Model	Order No.	Speed (in./min.)††	Type Pump	Valve Type	Pump Model***	Prod. Wt. (lbs.)
150	Double-Acting	13⅞"	RD15013	SPE15013DS	24 3.9	Electric*	4-way**	PQ1204S	3,015
200	Double-Acting	13⅞"	RD20013	SPE20013DS	18 2.9	Electric*	4-way**	PQ1204S	3,276

† Frame is shipped assembled.

†† Typical performance based on 100 psi and 10,000 psi pump specifications. Actual speeds may vary under operating conditions.

* Pre-wired at factory for 460V.

** Solenoid valve with 24 volt remote control hand switch.

*** Pump standard with press. Other Power Team pumps can be substituted. dBA at idle and 10,000 psi: 73/78, measured at 3 foot distance, all sides.

ROLL-BED® PRESS

80-200 Ton

H Frame

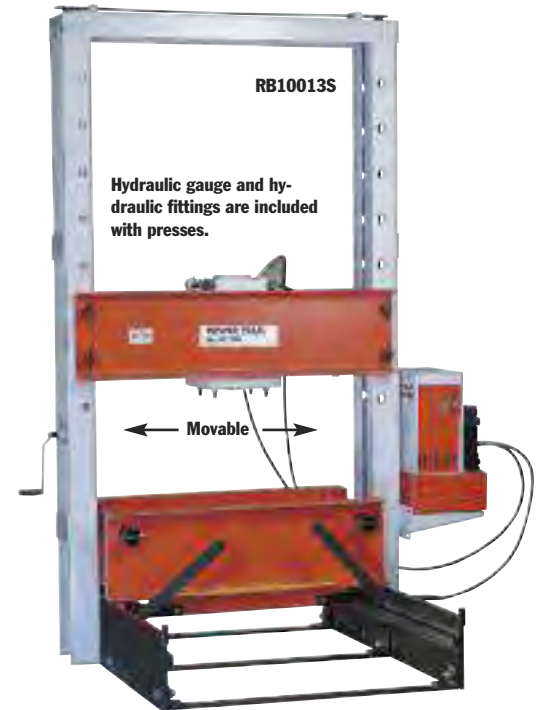

Heavy-Duty Straightening Fixtures



No. SF50 – Fixtures for use with 80-ton Roll-Bed® presses or 55-ton heavy-duty shop presses. (2 ea.). Wt. 104 lbs. **Not part of press, order separately.**



No. SF150 – Fixtures for use with 100-, 150- and 200-ton Roll-Bed® presses and 100-ton shop presses only (1 pr.). Wt. 196 lbs. **Not part of press, order separately.**



- The original, patented Roll-Bed® design. Bed rolls out for easy loading and unloading with a crane or other lifting device.
- Movable workhead glides easily side-to-side for full off-center load capacity across width of upper frame.
- “Daylight” is 50½" x 60" for 80- and 100-ton models; 51¼" x 64" on 150- and 200-ton presses.
- Fast approach of double-acting, 13⅜" stroke cylinder is provided by PQ1204S “Quiet” electric/hydraulic pump with remote control hand switch. Operator can view work from all sides with fingertip control of cylinder piston travel.

PRESS FEATURES:

- **Roll-Bed® design** – Bed glides in or out on bearings to make loading and unloading fast and easy.
- **Adjustable lower bed width** – For secure balancing and centering of heavy jobs. Loosen adjusting bolts to adjust bed from 4" to more than 27". See dimension “H.”
- **Movable workhead** – For off-center pressing jobs, workhead moves on bearings across upper bolster. Presses can be used at full capacity, regardless of where workhead is placed.
- **Lifting mechanism** – Simply turn crank handle to raise or lower upper bolster. Screw mechanism raises or lowers both sides evenly (a heavy-duty ½" drill motor can replace handle for automatic adjustment). Four locking pins hold bolster in place for pressing.

- **Optional heavy-duty straightening fixtures** – Make straightening jobs easy and accurate to within .004"! Rollers are ball bearing mounted and handle raises or lowers for easy turning of the work.

PUMP ELECTRICAL SPECIFICATIONS

PQ120 Series – 3 hp, 460 volt, 60 cycle, three phase. Available in 220/380 volt, 50 cycle, add suffix “-380” to order no.

NOTE: To order press with a 230 volt, 60 cycle, single phase pump, order press less PQ1204S. Order pump No. PQ604S separately.

NOTE: Different voltage and valve options can be obtained by substituting certain PA, PE or PQ series pumps. Consult the factory.



Lifting screw and locking pins make bolster raising a one-man job.



Bearings make bed positioning smooth and easy.



Lever lowers bed for pressing, raises it for rolling.



Cylinder is easily moved across width of upper bolster.



Width adjusts from 4" to over 27"; is secured with locking bolts.

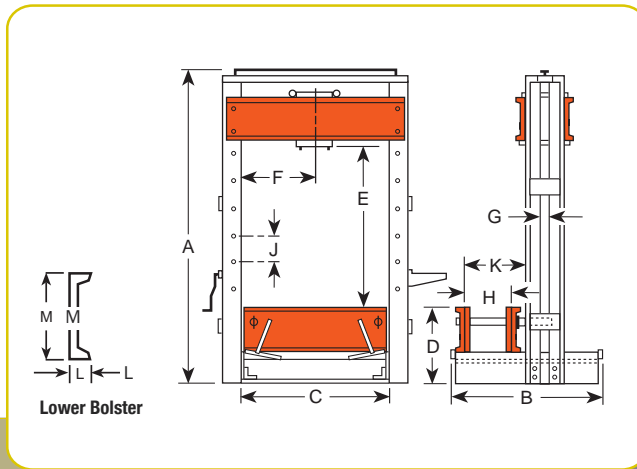

Lower Bolster



SHOP EQUIPMENT

DIMENSIONS

Cap Tons	A (in.)	B (in.)	C (in.)	D (in.)	E (in.)	F (in.)	G (in.)	H (in.)	J (in.)	K (in.)	L (in.)	M (in.)	Floor Space
80	112 ⁵ / ₈	64 ¹ / ₄	50 ¹ / ₂	27	12 - 60	14 ¹ / ₂ - 36	3	4 - 27 ¹ / ₄	8	36 ¹ / ₂	3 ³ / ₈	15	64 ¹ / ₄ x 60 ¹ / ₂
100	112 ⁵ / ₈	64 ¹ / ₄	50 ¹ / ₂	27	12 - 60	14 ¹ / ₂ - 36	3	4 - 27 ¹ / ₄	8	36 ¹ / ₂	3 ³ / ₈	15	64 ¹ / ₄ x 60 ¹ / ₂
150	123 ³ / ₄	68 ³ / ₄	51 ¹ / ₄	30	9 - 64	13 ⁷ / ₈ - 37 ³ / ₈	3	4 - 27 ¹ / ₈	11	37 ¹ / ₄	4 ¹ / ₈	18	68 ³ / ₄ x 63 ¹ / ₄
200	123 ³ / ₄	68 ³ / ₄	51 ¹ / ₄	30	9 - 64	15 ¹ / ₈ - 36 ¹ / ₈	3	4 - 27 ¹ / ₈	11	37 ¹ / ₄	4 ¹ / ₈	18	68 ³ / ₄ x 63 ¹ / ₄

ORDERING INFORMATION

Capacity (tons)†	Type of Cylinder Used	Stroke	Cylinder Model	Order No.	Speed (in./min.)††	Type Pump	Valve Type	Pump‡ Model	Prod. Wt. (lbs.)
80	Double-Acting	13 ¹ / ₈ "	RD8013	RB8013S	46 7.5	Elec.	4-way*	PQ1204S	2,886
100	Double-Acting	13 ¹ / ₈ "	RD10013	RB10013S	35 5.8	Elec.	4-way*	PQ1204S	2,944
150	Double-Acting	13 ¹ / ₈ "	RD15013	RB15013S	24 3.9	Elec.	4-way*	PQ1204S	4,458
200	Double-Acting	13 ¹ / ₈ "	RD20013	RB20013S	18 2.9	Elec.	4-way*	PQ1204S	4,546

* Solenoid valve with 24 volt remote control hand switch.

† Frame is shipped assembled.

‡ Pump standard with press. Other Power Team pumps can be substituted. dBA at idle and 10,000 psi: PQ120-73/78; measured at 3 foot distance, all sides.

†† Typical performance based on 100 psi and 10,000 psi pump specifications. Actual speeds may vary with operating conditions.

3,000 lbs maximum load can be supported on bed when raised on the rollers.

SHOP PRESS

Accessories

Rubber Tire Removing/Installing set

Now an easy way to press solid rubber tires. The TPP200 uses plates instead of combination rings to press a rim from an old tire into a new one. Plates are stacked so none is more than 2 in. smaller than the one under it to keep the plates from bending. They can be used on any Power Team press with 55-ton capacity or more. NOTE: Many tires require 100 tons of force or more, depending on tire size and condition. These plates withstand max. force of 150 tons.

No. TPP200 – Tire press plate set. Includes 13 press plates, spacer pushing adapter and press bed plate. For use on solid rubber tires from 4" to 17³/₄" I.D.

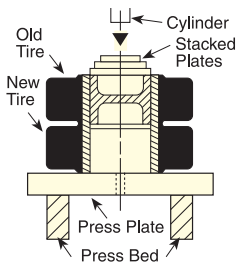

Pressing rim into new tire on Power Team Press.



TBP1622
16" x 22" x 2"



TPP1 - TPP13
3⁷/₈" - 17⁵/₈" x 3³/₄"



TPS6
3³/₄" x 6"

Order No.	Set No. TPP200 Tire Size I.D.	Plate O.D.
TPP1	4"	3 ⁷ / ₈ "
TPP2	5"	4 ⁷ / ₈ "
TPP3	6", 6 ¹ / ₄ "	5 ⁷ / ₈ "
TPP4	6 ¹ / ₂ "	6 ³ / ₈ "
TPP5	8"	7 ⁷ / ₈ "
TPP6	10"	9 ⁷ / ₈ "
TPP7	10 ¹ / ₂ "	10 ³ / ₈ "
TPP8	11 ¹ / ₄ "	11 ¹ / ₈ "
TPP9	12", 12 ¹ / ₈ "	11 ⁷ / ₈ "
TPP10	14"	13 ⁷ / ₈ "
TPP11	15"	14 ⁷ / ₈ "
TPP12	16"	15 ⁷ / ₈ "
TPP13	17 ³ / ₄ "	17 ⁵ / ₈ "
TPS6	Spacer/Pushing Adapter	3 ³ / ₄ " x 6"
TBP1622	Bed Plate	16" x 22" x 2"



PRESS ACCESSORIES, "V" BLOCKS & THREADED ADAPTERS

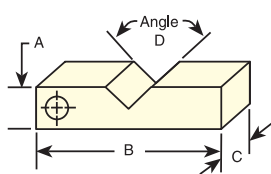

V-BLOCKS (in.)

Order No.	Width A	Length B	Thick C	Angle D
1890	2	9	1 ¹ / ₄	120°
1891	2 ¹ / ₂	11 ¹ / ₂	1 ³ / ₄	
1892	3 ¹ / ₂	14	2	
1893	5	14	1 ¹ / ₂	
207395	5 ³ / ₄	23	2 ¹ / ₂	

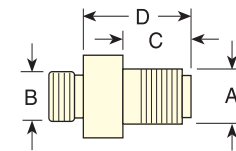

THREADED ADAPTER DIMENSIONS (in.)

Adapter No.	A	B	C	D
38597	1- 8	1- 8	3/4	1 ⁵ / ₁₆
38953	1 ¹ / ₄ - 7	1 ¹ / ₂ - 16	2 ³ / ₄	4 ³ / ₈
37368	1 ⁵ / ₈ - 5 ¹ / ₂	—	1 ¹¹ / ₁₆	2 ¹ / ₂
43562	2 ¹ / ₄ - 12	—	2 ¹ / ₄	3
38954	1 ⁵ / ₈ - 5 ¹ / ₂	1 ¹¹ / ₁₆ - 8	3 ¹ / ₄	4 ³ / ₁₆
43563	2 ¹ / ₄ - 12	2 ³ / ₄ - 12	2 ¹ / ₄	3 ³ / ₁₆
46070	2 ¹ / ₄ - 12	2 - 4 ¹ / ₂	2 ¹ / ₄	3 ³ / ₁₆

Press Accessory Kit

Make your Power Team press even more versatile with one of these accessory sets. These sets will eliminate makeshift set-ups. Many of these items can be used with pullers you already have.

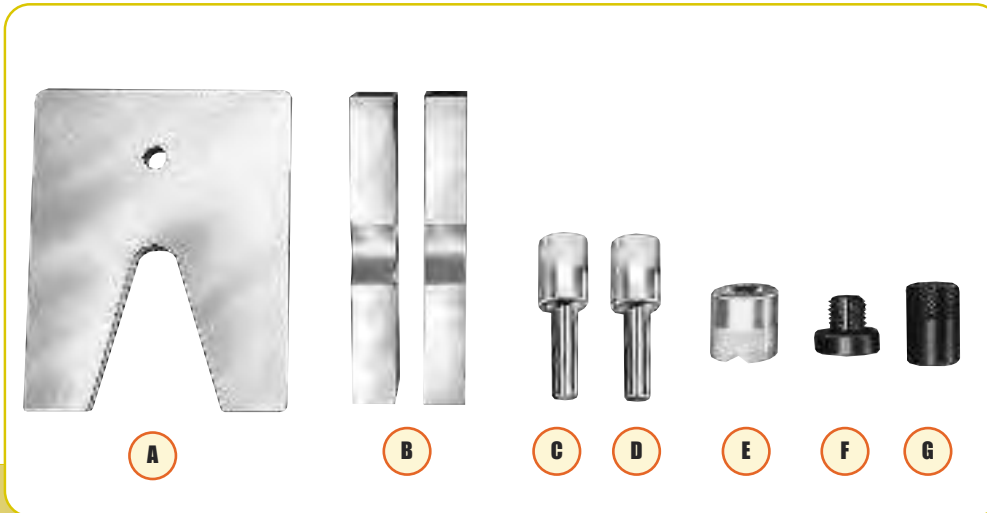

ORDERING INFORMATION

Use With Press:	Order No.	A		C	D	E	F		G
		Press Plate	V-Blocks				Pushing Adapter	Single-Acting Cyls.	
10 Ton	SPA10	1888	1890 (Pr.)	201923 1/2" dia. shank	201454 3/4" dia. shank	34806	Included in Set 38597		
25 Ton	SPA25	1889	1891 (Pr.)	34510 3/4" dia. shank	34511 1" dia. shank	34807	Included in Set 38953		
55 Ton	SPA55	—	1892 (Pr.)	34755 1" dia. shank	34756 1 1/2" dia. shank	34808	Not Included Order Separately — 37368		38954
80/100 Ton	SPA100	—	1893 ** (Pr.)	—	—	36469	Not Included Order Separately 43562		21332
150/200 Ton	SPA200	—	207395 (Pr.)	—	44458 2 1/4" dia. shank	44457	None* 46070 ***		43563 46070

* Pushing adapters thread directly into RD15013 and RD20013 cylinders.

** V-blocks, No. 1893, are recommended for use with 80-ton Roll-Bed® press. Not recommended for use with 100-ton Roll-Bed®.

*** For 80-ton Roll-Bed® press.

NOTE: Individual press accessories may be ordered separately.



CAUTION: Pushing adapters are designed for use with specific shaft sizes, and depending on the condition of the shaft ends, the adapter may not withstand the full press tonnage. Always use a protective blanket or other suitable guard when pressing.

SHOP EQUIPMENT



MOBILE FLOOR CRANES

2200-4400 lbs.

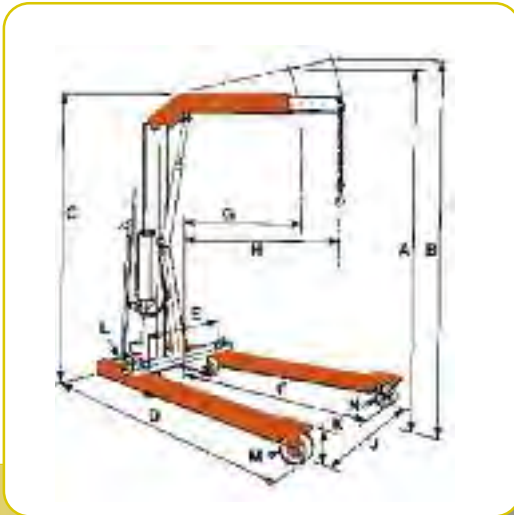

DIMENSIONS

	FC2200*	FC4400*
Cap., boom ret. (lbs.)	2,200	4,400
Cap., boom ext. (lbs.)	1,650	3,300
A Max. boom hgt., (ret.)	107"	111"
B Max. boom hgt., (ext.)	117"	122"
C Overall hgt., boom horiz.	80"	82"
D Overall length	83"	89"
E Min. throat width	24"	25"
F Inside leg length	54"	57½"
G Eff. boom reach (ret.)	33"	35½"
H Eff. boom reach (ext.)	48"	50½"
J Inside leg width	24" - 36" - 48"	26" - 40" - 52½"
	(3-position)	(3-position)
K Leg height	8"	9½"
L Dolly wheel diameter	5"	5"
M Wheel diameter	6"	8"
N Caster diameter	6"	6"
Floor space, folded	27" x 38"	31" x 42"
Height, folded	79"	86"

FC2200

U.S. Patent No. 3,367,512
Patented 1969 Canada

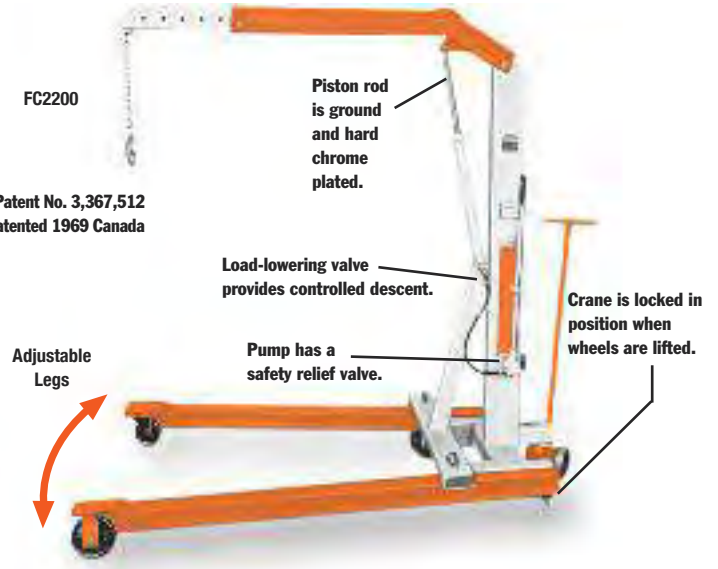

2,200 lbs. and 4,400 lbs. capacity
with space-saving fold-away
feature



- Adjustable legs spread to clear obstacles, telescoping boom for extra reach. Rugged construction, reliable hydraulics.
 - Boom collapses completely and legs fold for compact storage.
 - 2-speed hydraulic hand pump provides fast boom travel and precise operator controlled descent.
 - Roller bearing wheels and a steering dolly provide ease of mobility. Lifting chain is included.
- No. FC4400** – 4,400 lbs. cap. crane with fold-away feature, adj. leg spread, lifting chain and 2-speed hand pump. Wt., 646 lbs.

LOAD-ROTORS®

TILTERS

2000-6000 lbs.

Load-Rotors®



"Tilter" LR6000
6,000 Lbs. Capacity



LR2000
2,000 Lbs.
Cap.

LR4000
4,000 Lbs.
Cap.



- For lifting or positioning components, Power Team's heavy duty lifting slings are just right.
- The heavy-duty Load-Rotors®, when used with a crane or hoist, greatly reduce time and effort.
- A self-locking worm and gear set in the Load-Rotor® head permits rapid angle adjustment of the component being handled.
- Whenever you have big, heavy components to move or position, nothing helps you get the job done easier and faster than the 6,000 lb. "Tilter."

* Note: not to be used for overhead lifting.

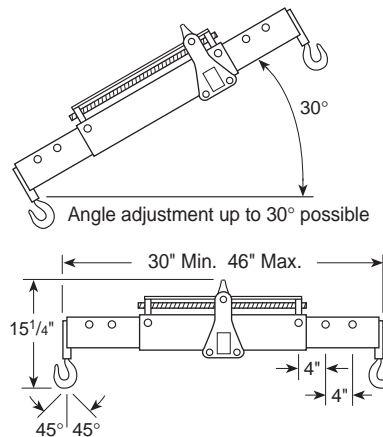

The working length is adjustable in three positions from 30" to 46". Maximum chain angle is 45°.



SHOP EQUIPMENT

ORDERING INFORMATION

Capacity (lbs.)	Order No.	Chain Size (in.)	Chain Lg. W/ Swivel Hooks (in.)	Lifting Eye Opening (in.)	Hex Drive End (in.)	Gear Ratio	Product Wt. (lbs.)
2000	LR2000	1/4	56	1 1/4	5/8	34:1	9
4000	LR4000	5/16	65	1 3/4	5/8	82:1	23
6000	LR6000	5/16	65	1 5/8	5/8	82:1	73

JACKS



STROKE

Series	Description	Pg	1.1 Ton	2 Ton	3 Ton	3.6 Ton	5 Ton	5.5 Ton	6 Ton	7 Ton	8 Ton	10 Ton	11 Ton	12 Ton	13 Ton	15 Ton
	Bottle Jack Std	150		4.5"	4.5"		4.75"				4.75"			5.875"		6.125"
	Bottle Jack Low Profile	151												3.75"		
	Toe Jacks Std	152						8.25"					9.25"			
	Toe Jacks Economy	153		4.875"			4.875"					5.875"				
	Bottle Jacks Telescoping	154							12"				10.3"		10"	7.125"
	Bottle Jacks Sidewinder	155					.75"/1.5					1.1875"				
SJ	Post Tension/Stressing Jacks	157														
IJ	Inflatable Jacks	158	2.7"			4.7"				6.3"				8.8"		
PL	High Tonnage Portable Jack RR	160														
PM	High Tonnage Portable Jack	162														

Page
BOTTLE JACKS...150
2-110 TON



Page
...151
LOW PROFILE
BOTTLE JACKS
12-30 TON



Page
...152
TOE JACKS
5 1/2 - 27 1/2 TON



Page
ECONOMY TOE
JACKS ...153
2-10 TON



Page
...154
TELESCOPING JACKS
BOTTLE JACKS



Page
...155
SIDEWINDER JACKS



Page
...156
MAINTENANCE SETS



Page
...157
POST TENSION JACKS
20-30 TON



Page
...158-159
INFLATABLE JACKS
1-74 TON



Page
...160-163
PORTABLE
HIGH TONNAGE
RAILROAD JACKS



20 Ton	22 Ton	23.8 Ton	27.5 Ton	30 Ton	33 Ton	34 Ton	46.3 Ton	50 Ton	55 Ton	60 Ton	74.6 Ton	100 Ton	110 Ton	150 Ton
6.25"	6.125"			6.25"	5.625"			6.75"					6.125"	
3.375"				3.125"										
			9.1875"											
1.1875"														
8.5"/10"				8.5"/10"										
		12"				14"	16.4"				20.5"			
										14"		14"		
								13.125"				13.125"		18.125"

BOTTLE JACKS

2-110 Ton

Portable hydraulic power



INDUSTRIAL LIFTING AND PUSHING APPLICATIONS.

- Choose from this complete line of premium-quality, standard bottle jacks. Ideal for use in any number of industrial lifting and pushing applications.

- The 9110B, 9015B, 9022B and 9033B feature a beveled base which allows the jack to “follow” the load, reducing the chance of dangerous side-loading.
- Many jacks feature screw extensions
- All jacks can be used in the vertical, angled or horizontal positions.

- Serrated or contoured saddles help stabilize the load for a safer lift.
- All jacks meet ASME B30.1 standards and carry the Power Team Marathon Lifetime Warranty.
- 110-ton jack features dual pumps for time-saving two-speed operation.



ORDERING INFORMATION*

Cap. Tons	Stroke (in.)	Order Number	Retracted Height (in.)	Length of Screw (in.)	Height w/Screw Ext. (in.)	No. Pump Strokes to Ext. Piston (in.)	Saddle Dia. (in.)	Base Size (in.)	Pump Handle Length (in.)	Handle Effort at Rated Cap. (lbs.)	Carry Handle	Product Weight (lbs.)
2	4 ¹ / ₂	9002A	7 ¹ / ₈	1 ¹⁵ / ₁₆	13 ⁹ / ₁₆	5	1	4 ¹¹ / ₃₂ x 2 ⁹ / ₁₆	12 ¹ / ₄	75	No	4.8
3	4 ¹ / ₂	9003A	7 ¹ / ₂	2 ³ / ₈	14 ³ / ₈	10	1 ¹ / ₈	4 ¹ / ₂ x 2 ²⁷ / ₃₂	19 ¹ / ₄	45	No	5.8
5	4 ³ / ₄	9005A	7 ⁷ / ₈	2 ³ / ₄	15 ³ / ₈	12	1 ³ / ₈	5 ³ / ₁₆ x 3	21 ⁷ / ₁₆	55	No	8
8	4 ³ / ₄	9008A	7 ⁷ / ₈	2 ³ / ₄	15 ³ / ₈	18	1 ¹ / ₂	6 x 3 ¹ / ₂	23 ¹³ / ₁₆	75	No	12.1
12	5 ⁷ / ₈	9112A	9 ¹ / ₂	3 ¹ / ₈	18 ¹ / ₂	26	1 ⁷ / ₈	6 ¹ / ₂ x 4 ³ / ₁₆	23 ¹³ / ₁₆	60	Yes	17.5
15	6 ¹ / ₈	9015B	9 ² / ₁₆	4 ¹ / ₂	19 ⁷ / ₈	27	2 ³ / ₈	5 ¹ / ₈ x 5 ¹ / ₂ †	27 ⁹ / ₁₆	90	No	18.3
20	6 ¹ / ₄	9120A	10 ⁵ / ₈	3 ⁵ / ₈	20 ¹ / ₂	22	2	7 ³ / ₁₆ x 5 ¹ / ₁₆	31 ¹ / ₂	70	Yes	28.5
22	6 ¹ / ₈	9022B	9 ⁷ / ₁₆	4 ⁵ / ₁₆	20 ¹ / ₂	36	2 ³ / ₈	6 ¹ / ₂ x 6 ⁵ / ₁₆ †	27 ⁹ / ₁₆	90	Yes	23.6
30	6 ¹ / ₄	9030A	11	—	17 ¹ / ₄	35	2 ³ / ₈	7 ⁹ / ₁₆ x 5 ⁹ / ₁₆	39 ³ / ₈	50	Yes	41.2
33	5 ⁵ / ₈	9033B	9 ⁷ / ₁₆	4 ³ / ₁₆	19 ³ / ₄	56	2 ⁹ / ₁₆	7 ¹ / ₄ x 6 ¹⁵ / ₁₆ †	27 ⁹ / ₁₆	88	Yes	32
50	6 ³ / ₄	9050A	12	—	18 ³ / ₄	35	3	9 ⁵ / ₁₆ x 7 ³ / ₈	39 ³ / ₈	85	Yes	78
110	6 ¹ / ₈	9110B	11 ¹³ / ₁₆	—	17 ¹⁵ / ₁₆	40/160‡	4 ³ / ₈	13 ³ / ₈ x 11 ⁷ / ₁₆	27 ⁹ / ₁₆	79	Yes	154.3

*See current price list for shipping weights.

† Comes with a Beveled Base

‡ 2 Speed: Rapid advance≈40 strokes; Lift mode≈160 strokes

BOTTLE JACKS

Low Profile
12, 20 & 30 Ton



THE RIGHT CHOICE FOR THOSE LOWER CLEARANCE JOBS.

- All the quality, features and lifting capacity of the standard jacks in short form. The 12-ton and 20-ton models feature screw extensions for added versatility.

- All jacks meet ASME B30.1 standards and carry the Power Team Marathon Lifetime Warranty.

- All jacks operate both vertically and horizontally for use in a variety of lifting, pushing and spreading applications.



ORDERING INFORMATION*

Cap. Tons	Stroke (in.)	Order Number	Retracted Height Min. (in.)	Length of Screw Ext. (in.)	Height w/Screw Ext. (in.)	No. Pump Strokes to Ext. Piston (in.)	Saddle Dia. (in.)	Base Size (in.)	Pump Handle Length (in.)	Handle Effort at Rated Cap. (lbs.)	Carry Handle	Product Weight (lbs.)
12	3 ³ / ₄	9012A	6 ³ / ₄	3	13 ¹ / ₂	26	1 ⁷ / ₈	6 ¹ / ₂ X 4 ³ / ₁₆	23 ¹³ / ₁₆	60	Yes	14
20	3 ³ / ₈	9020A	7 ¹ / ₈	1 ⁹ / ₁₆	12	22	2	7 ³ / ₁₆ X 5 ¹ / ₁₆	31 ¹ / ₂	70	Yes	22.2
30	3 ¹ / ₈	9130A	7 ¹ / ₈	—	10 ¹ / ₄	35	2 ³ / ₈	7 ⁹ / ₁₆ X 5 ⁹ / ₁₆	39 ³ / ₈	50	Yes	30.2

* See current price list for shipping weights.

† 2 Speed: Rapid advance≈40 strokes; Lift mode≈160 strokes

TOE JACKS

5.5, 11 & 27.5 Ton

GET UNDER EQUIPMENT WITH ONLY 11/16" OF GROUND CLEARANCE.

- With lifting points on the toe and on the top, these extremely rugged jacks are ideal for machine lifting, rigging, lift truck service and much more.
- Choose from 5.5-ton, 11-ton, and now, an amazing 27.5-ton lifting capacity.
- All jacks operate both vertically and horizontally.
- Base, toe and pumping assembly swivel independently, allowing the jack to work in confined areas.



ASME B30.1



The J Series Toe Jack is an extremely rugged jack used here for lift truck service.

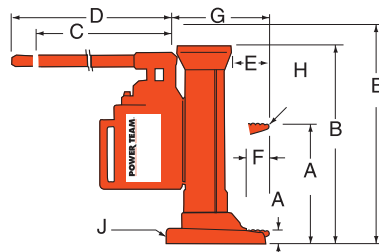

Order Number	A		B		C	D	E	F	G	H	J
	Ret. (in.)	Ext. (in.)	Ret. (in.)	Ext. (in.)							
J58T	1 ¹ / ₁₆	9 ³ / ₈	14 ³ / ₄	23	14 ¹ / ₂	17 ³ / ₄	2 ¹³ / ₁₆	2 ³ / ₁₆	6 ¹⁵ / ₁₆	1 ⁵ / ₈	5 ¹ / ₈
J109T	1 ¹ / ₁₆	10 ³ / ₈	16 ¹ / ₂	25 ³ / ₄	14 ¹ / ₂	17 ³ / ₄	3	2 ³ / ₁₆	7 ¹ / ₃₂	2 ¹ / ₂	6 ³ / ₄
J259T	2 ¹ / ₈	11 ³ / ₈	19 ⁷ / ₈	29 ⁷ / ₁₆	8 ¹ / ₄	29 ³ / ₄	5 ³ / ₄	4	10 ¹ / ₂	3 ¹ / ₂	10 ⁵ / ₈

Cap. Tons	Max Lift Stroke	Order Number	Strokes to Extend Piston 1 in.	Handle Effort at Max Load (lbs.)	Carry Handle	Product Wt. (lbs.)
5 ¹ / ₂	8 ¹ / ₄	J58T	8	83.9	Yes	43
11	9 ¹ / ₄	J109T	13	88	Yes	64
27 ¹ / ₂	9 ³ / ₁₆	J259T	21	88	Yes	203

*See current price list for shipping weights.

TOE JACKS

Economy

2, 5 & 10 Ton



**JUST THE POWER YOU NEED
AT A PRICE YOU CAN AFFORD.**

- These bottle jack-style toe jacks are loaded with many of the same features as our standard bottle jacks, but the toe-lift feature and swiveling pump handle make them ideal for machinery lifting and positioning.
- An internal pressure relief provides added safety by limiting the jack's lifting capability to the capacity of the toe.
- Spring return is an added feature on the larger jacks.
- Swiveling pump handle assembly available on the 5- and 10-ton models. The swiveling jack assembly allows you to access and pump the unit from numerous positions.

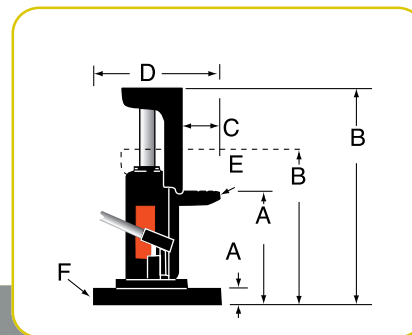

DIMENSIONS

Order Number	A		B		C	D	E	F
	Ret. (in.)	Ext. (in.)	Ret. (in.)	Ext. (in.)				
J24T	5/8	5 1/2	9 1/4	14	1 7/8	7 1/8	2	4 15/16
J55T	1	5 7/8	11 1/2	16 3/8	1 7/8	10 1/8	3	7 1/4
J106T	1 1/4	7 1/8	12 7/8	18 3/4	2 1/2	11 1/2	3 15/16	9 1/2

ORDERING INFORMATION*

Cap. Tons	Max Lift Stroke	Order Number	Strokes to Extend Piston		Handle Effort at Max Load (lbs.)	Product Carry Handle	Product Wt. (lbs.)
			1 in.				
2	4 3/4	J24T	14		42	Yes	18.3
5	4 7/8	J55T	22		60	Yes	53
10	5 7/8	J106T	31		73	Yes	83.8

*See current price list for shipping weights.

BOTTLE JACKS

Telescoping

6-15 Ton

THESE JACKS OFFER GREATER EXTENDED LIFTING CAPABILITY.



ASME B30.1

- Telescoping jacks offer all of the quality features and capabilities of the standard bottle jack line with a bonus. The super-long stroke of these jacks saves time and effort by eliminating the need to lift, crib, lift, etc. In most applications, the user can place the jack once and complete the lift.
- The 9015X offers very low clearance capability, making it the ideal choice for forklift maintenance or machine lifting.
- The taller 9006X, 9011X and 9013X all feature a unique beveled base that allows the jack to “follow” the load laterally as it is raised, greatly reducing side-loading of the piston.



ORDERING INFORMATION*

Cap. Tons	Stroke (in.)	Order Number	Retracted Height (in.)	Length of Screw Ext. (in.)	Height w/Screw Ext. (in.)	No. Pump Strokes to Ext. Piston (in.)	Saddle Dia. (in.)	Base Size Beveled Base † (in.)	Pump Handle Length (in.)	Handle Effort at Rated Cap. (lbs.)	Carry Handle	Product Weight (lbs.)
6	12	9006X	8 ¹ / ₂	—	20 ¹ / ₂	14	1 ³ / ₄	4 ³ / ₄ X 5 ¹ / ₄ †	27 ⁹ / ₁₆	79	No	14
11	10.3	9011X	7 ⁷ / ₈	2 ¹¹ / ₁₆	20 ⁷ / ₈	25	1 ⁵ / ₈	6 ⁵ / ₁₆ X 6 ¹ / ₂ †	27 ⁹ / ₁₆	88	No	19.5
13	10	9013X	9 ¹ / ₁₆	3 ⁵ / ₁₆	22 ⁷ / ₁₆	35	1 ⁷ / ₈	6 ¹⁵ / ₁₆ X 7 ⁵ / ₁₆ †	27 ⁹ / ₁₆	79	Yes	25
15	7 ¹ / ₈	9015X	6 ¹¹ / ₁₆	2 ³ / ₄	16 ¹ / ₂	32	2 ¹ / ₁₆	5 ⁵ / ₈ X 7 ⁵ / ₈	23 ⁵ / ₈	95	Yes	26.5

*See current price list for shipping weights.

SIDEWINDER JACKS

Mini jacks

5-20 Ton



COMPACT SIDEWINDER MINI JACK FITS IN YOUR PALM AND DELIVERS 5, 10 & 20 TONS OF LIFTING FORCE.

ASME B30.1



- Retracted height of just $2\frac{9}{16}$ " for the smallest jack and $5\frac{1}{8}$ " for the 20 ton, allows you to slip this jack into the narrowest of crevices.
- The perfect addition to any toolbox, this remarkable little jack has multiple uses that are limited only by your imagination. Use it as a jack or a spreader. Use it to turn your mechanical gear puller (puller capacity must match jack capacity) into a hydraulic puller. Use it vertically or horizontally in limited clearance.
- Jacks operate either horizontally or vertically. Handles function in line with base for easier use in confined spaces.



ORDERING INFORMATION*

Cap. Tons	Stroke (in.)	Order Number	Retracted Height Min. (in.)	Max Height (in.)	No. Pump Strokes to Ext. Piston	Saddle Dia. (in.)	Base Size (in.)	Pump Handle Length (in.)	Handle Effort at Rated Cap. (lbs.)	Carry Handle	Product Weight (lbs.)
5	$\frac{3}{4}$	9105A	$2\frac{1}{2}$	$3\frac{3}{8}$	30	$\frac{1}{9}$ / ₆₄	$2\frac{29}{32}$ Dia.	$\frac{9}{16}$	57	No	4.2
5	$1\frac{1}{2}$	9205A	$3\frac{1}{2}$	$5\frac{1}{8}$	38	$\frac{1}{9}$ / ₆₄	$2\frac{29}{32}$ Dia.	$\frac{9}{16}$	57	No	5.3
10	$1\frac{3}{16}$	9210A	$4\frac{3}{4}$	$5\frac{7}{8}$	36	$1\frac{21}{32}$	$4\frac{21}{64}$ Dia.	$17\frac{21}{64}$	62	No	12.1
20	$1\frac{3}{16}$	9220A	$5\frac{1}{8}$	$6\frac{5}{16}$	46	$2\frac{5}{64}$	$4\frac{23}{32}$ Dia.	$23\frac{13}{16}$	77	No	17.6

*See current price list for shipping weights.

MAINTENANCE SETS

Hydraulic system components



APPLICATION FLEXIBILITY

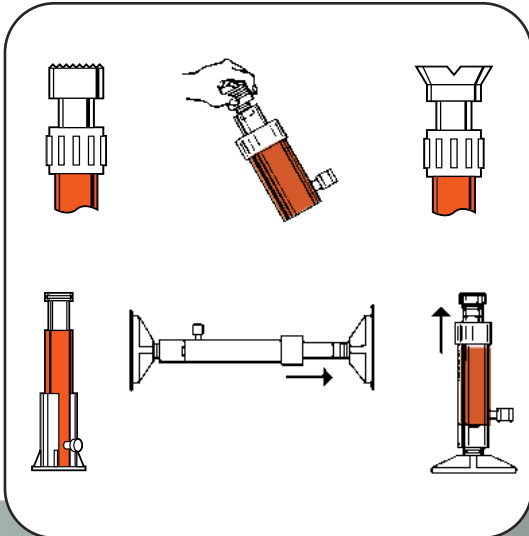

- Matched hydraulic system components, adapters and hydraulic spreader, contained in a rugged carrying and storage case.
- Portable sets are ideal for pushing, pulling, lifting, straightening, or clamping at remote job sites.
- Cylinders in set are rated at 10 tons at 10,000 psi. Set components are designed for full rated capacity of cylinders.
- Set IM10H/IM10L includes hand operated pump. Set IM10E includes the Quarter Horse® electrically driven portable power unit.



JACKS

ORDERING INFORMATION*

CONTENTS OF SET NO. IM10E		CONTENTS OF SET NO. IM10H			NO. IM10L	
Description	Order No.	Description	Order No.	Order No.	Order No.	Order No.
Hydraulic spreader	HS2000	Hydraulic spreader	HS2000	HS2000	HS2000	HS2000
Hand pump (electric)	PE102	Hand pump	P59	P59L	P59L	P59L
10,000 psi hyd. gauge	9041	10,000 psi hyd. gauge	9041	9041	9041	9041
Tee adapter	9670	Tee adapter	9670	9670	9670	9670
Hose & coupler assembly	9754	Hose & coupler assembly	9754	9754	9754	9754
90° V base	25395	90° V base	25395	25395	25395	25395
Threaded coupler	25664	Threaded coupler	25664	25664	25664	25664
Serrated saddle	31772	Serrated saddle	31772	31772	31772	31772
Flat base	32325	Flat base	32325	32325	32325	32325
Extension rod - 5" length	350897	Extension rod - 5" length	350897	350897	350897	350897
Extension rod - 10" length	38909	Extension rod - 10" length	38909	38909	38909	38909
Extension rod - 18" length	350898	Extension rod - 18" length	350898	350898	350898	350898
Cyl. support base	420062	Cyl. support base	420062	420062	420062	420062
Cyl. ass'y, 10 ton, 10 ¹ / ₈ " stroke	C1010CBT	Cyl. ass'y, 10 ton, 6 ¹ / ₈ " stroke	C106CBT	C106CBT	C106CBT	C106CBT
Cyl. ass'y, 10 ton, 6 ¹ / ₈ " stroke	C106CBT	Storage box*	350722	350722	350722	350722
Storage box*	350722					
	Prod. Weight – 106 lbs.		Prod. Weight – 89 lbs.	Prod. Weight – 81 lbs.		

* Actual product may differ from photo.

POST TENSION & Stressing jacks 20 & 30 Ton

**SJ2010
SJ3010**



**SJ2010DA
SJ3010DA**

- Power Team Monostrand Stressing Jacks are the most durable in the industry.
- Ideally suited for work on slab-on-grade where dirt, heat and high volume use take their toll.
- Available in single- or double-acting models.
- Standard single-acting units have a 10" stroke. Other stroke lengths are available on special order.
- Dead-end seaters for production work and field work available on special order. **(Part #400120)**
- Service repair is simple; components are long lasting and easily replaced.
- 3" detachable seater nose assembly easily replaced with optional 6" nose assembly.
- The jack of choice for high-rise and elevated work, thanks to fast return time and light weight.
- All hydraulic fluid controls are interior designed; more efficient and safer operation during tensioning and retraction.
- Standard double-acting units have an 8½" stroke; others available on special order.
- Specially designed Power Team Control Valves are available for post tensioning jacks. See pages 129.

ORDERING INFORMATION*

Description	Cyl. Cap. Tons	Stroke (in.)	Order Number	Recommended Pumps for this Stressing Jack	Oil Capacity (cu. in.)	Strand Diameter (in.)	Seater Type	Internal Pressure at Capacity	Tons at 10,000 psi	Weight (lbs.)
Post tension jack with spring seater, 0.50" strand.	20	10	SJ2010	PE554P/PE604T	45.2	.375-.50	Spring	8,948	22.4	55
Post tension jack with power seater, 0.50" strand.	20	10	SJ2010P	PE554PT/PE604PT	45.2	.375-.50	Power	8,948	22.4	55
Double-acting post tension jack with power seater, 0.50" strand.	20	8½"	SJ2010DA	PE554PT/PE604PT	53.0	.375-.50	Power	7,575	26.4	42
Post tension jack with spring seater, 0.60" strand.	30	10	SJ3010	PE554P/PE604T	63.6	.375-.60	Spring	9,549	31.4	76
Post tension jack with power seater, 0.60" strand.	30	10	SJ3010P	PE554PT/PE604PT	63.6	.375-.60	Power	9,549	31.4	76
Double-acting post tension jack with power seater, 0.60" strand.	30	8½"	SJ3010DA	PE554PT/PE604PT	67.6	.375-.60	Power	7,554	39.7	52

*See current price list for shipping weights.

STRESSING JACK ACCESSORIES AND HOSES—ORDERING INFORMATION

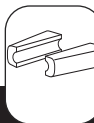
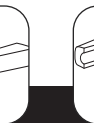
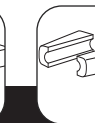
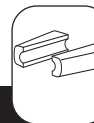
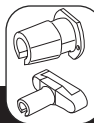
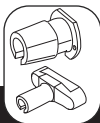

Used with Stressing Jack	3" Nose Piece	3" Wedge Seater	6" Nose Piece	6" Wedge Seater	3/8" Diameter Gripper Set	7/16" Diameter Gripper Set	1/2" Diameter Gripper Set	19/32" Diameter Gripper Set	Replacement Gripper Handle	Gripper Retainer Plate (2 used)
SJ2010	252564	252562	252759	252763	252568	252761	252567	NA	252570	252565
SJ2010P	252564	252562	252759	252763	252568	252761	252567	NA	252570	252565
SJ2010DA	252543	252542	252760	252764	252650	252762	252555	NA	252556	252544
SJ3010	252564	252562	252759	252763	252568	252761	252567	252569	252570	252565
SJ3010P	252564	252562	252759	252763	252568	252761	252567	252569	252570	252565
SJ3010DA	253363	253361	253364	253362	253390	NA	253391	253365	252556	252544

No. 9758 Hose - 10 ft. rubber, wire-braid (2-ply, 20,000 psi burst rating) 3/8" NPTF male hose ends

No. 9763 Hose - 10 ft. rubber, wire-braid (2-ply, 20,000 psi burst rating) 3/8" x 1/4" NPTF male hose ends



INFLATABLE JACKS

1-74 Ton

IJ Series Inflatable Air Jacks



The non-skid space age reinforced inflatable jack is perfect for many applications.

- Highly flexible and lightweight jacks only require an air supply of 116 psi maximum. Any non-explosive gas or water can also be used for inflation.
- Uninflated jacks are only 1" thick, making seemingly impossible lifting tasks routine.
- Space age reinforced, multi-layer aramid construction, widely overlapping on all sides. Tested at 175 psi.
- In rugged testing, jacks withstood tens of thousands of inflate/deflate cycles at 116 psi.
- Large surface area and material flexibility allow jacks to lift loads on soft or compressible surfaces without support cribbing being necessary.
- Safety first! The controller, shut-off and air hoses are all equipped with USA industrial interchange style air couplers. Female half coupler bodies have a locking collar, protecting operator from accidentally disconnecting jack while under load.
- Surface of jack has a non-skid pattern, assuring that the jack won't "walk away" from the job. Jacks can be used to lift a load from an uneven surface, are tolerant of side-loaded applications.
- Non-conducting material resists oil, ozone and most chemicals. Cold resistant down to -40° F, heat resistant up to 240° F (short term) or 200° F (long term).

- Field-replaceable nipples are made of tough steel, with internal thread to prevent abrasion damage. Ideal needle aperture of 1/4" allows rapid inflation, without risk of icing, and permits a safe lowering speed.
- Single jack controller with "dead man" control (350090). Can be used individually, or in multiples to regulate any number of jacks desired.
- Heavy attachment straps are provided on 4 largest sizes for attachment of a rope or hook to position the jack from a safe distance.
- Inflation hose system is color-coded (red and yellow) for easy recognition when using more than one jack.

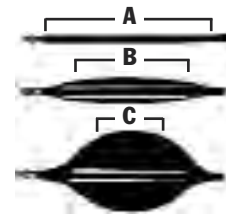

Maximum Effective Lifting Area

All lifting capacities mentioned in the charts are measured at the maximum effective lifting area (A). As the jack is inflated (B), this effective area decreases (C) due to the rounded shape of the jack. Lifting capacity also decreases (see performance chart).



Stack up to two jacks together to increase effective lifting height.

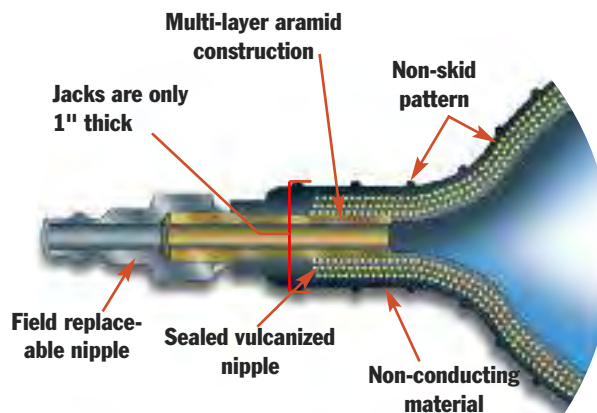



350090*



307159



350208
350209



350207



250343



250353



250682



15235



250341



250342

* NOTE: 350090 air controller may be used individually to control one jack (see single line system), or in multiples to control additional jacks (see dual line system).

No. 307159 – Pressure reducing valve. Allows use of bottled gases to operate jacks (works on CGA-580 Nitrogen/Argon/Helium bottles). Contains standard bottle fitting on inlet and 1/4" industrial interchange (female) outlet. Wt., 4 lbs.

No. 350090 – Air controller for single jack. Equipped with relief valve and pressure gauge.

No. 350207 – Shut-off hose with shut-off valve and pressure relief valve. Includes a female and male quick coupler.

No. 350208 – Air hose. Red, 30' long. Includes No. 250341 female and No. 250342 male quick coupler.

No. 350209 – Air hose. Same as 350208, except blue in color.

No. 250343 – Female quick coupler. 1/4" industrial interchange x 1/8" NPT female. Wt., 0.1 lb.

No. 250353 – Male quick coupler. 1/4" industrial interchange x 1/8" NPT male. Wt., 0.1 lb.

No. 250682 – Female quick coupler. 1/4" industrial interchange x 1/4" NPT male. Wt., 0.1 lb.

No. 15235 – Connector 1/8" NPT male x 1/4" NPT female. Wt., 0.1 lb.

No. 250341 – Female quick coupler. 1/4" industrial x 3/8" I.D. hose.

No. 250342 – Male Quick coupler. 3/8" I.D. Hose.

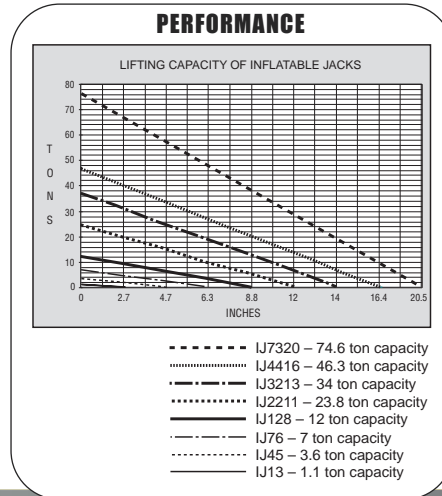
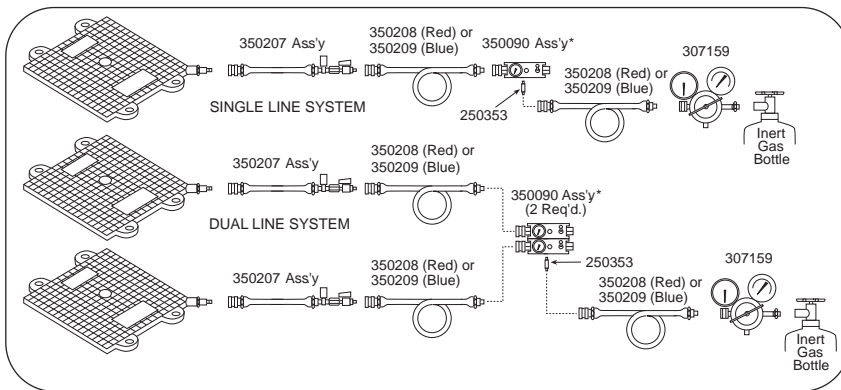

ORDERING INFORMATION*

Lifting Cap. (tons)	Lifting Height (in.)	Order Number	Air Contents at 116 psi (cu. ft.)	Max. Working Pressure (psi)	Length (in.)	Width (in.)	Collapsed Height (in.)	Product Weight (lbs.)
1.1	2 ⁴⁵ / ₆₄	IJ 13	.08	116	5 ¹ / ₂	5 ⁷ / ₆₄	1	1
3.6	4 ⁴⁵ / ₆₄	IJ 45	.50	116	10	7 ²⁹ / ₃₂	1	3
7	6 ¹⁹ / ₆₄	IJ 76	1.48	116	12	12	1	4
12	8 ⁵¹ / ₆₄	IJ 128	3.40	116	15 ⁴⁵ / ₆₄	15 ⁴⁵ / ₆₄	1	8
23.8	12	IJ 2211	9.50	116	21 ⁴⁵ / ₆₄	21 ⁴⁵ / ₆₄	1	16
34	14	IJ 3213	16.40	116	25 ³⁹ / ₆₄	25 ³⁹ / ₆₄	1	22
46.3	16 ¹³ / ₃₂	IJ 4416	25.70	116	29 ⁷ / ₂	29 ⁷ / ₂	1	29
74.6	20 ¹ / ₂	IJ 7320	51.40	116	37 ¹³ / ₃₂	37 ¹³ / ₃₂	1 ¹³ / ₆₄	58

*See current price list for shipping weights.

PORTABLE HIGH TONNAGE JACKS

60-100 Ton
Railroad Edition

- Patented load lowering valve. Lowers load smoothly and safely. Eliminates dangerous chatter and bounce.
- Full range of rod extensions. Jack comes fully equipped with extensions to match lifting pad heights on most rolling stock. Max. lifting height to 70".
- Low collapsed height, long stroke. 24" (61 cm) collapsed height for low-clearance lift pads. 14" (36 cm) stroke for maximum lift.
- Contact factory for lower collapsed heights.
- Adjustable, ergonomic handle. Handle tilts to start the job and is easily locked/unlocked without moving from operating position.
- Cribbing block set with handles and convenient storage rack. Provides solid mechanical load holding.
- High-profile, low rolling resistance, foam-filled tires. Jack can be moved and positioned with minimal effort. No chance of downtime due to punctured tires.
- Electric and air motor options. Quiet, powerful air and electric motor powered units available.
- Contact factory for custom cribbing block sizes and piston rod extensions.



POWER UNIT SPECIFICATIONS

Order No.	Motor	Power Req.	Motor Control	Valve Function	Power Cord	dBa @ 10,000 psi
PLE6014	1 $\frac{1}{8}$ HP	25 amps	20'	Lift	Pigtail	80/95
	110/115 VAC***		Remote Control	Hold		
	50/60 HZ			Lower		
	Single Phase			Manual		
PLA6014	Rotary Air Powered	50 CFM @ 80 PSI	20' Remote Air Control	Lift Hold Lower Manual	NA	82

*** For 220V order PLE6014-220



**Air Model
(PLA6014)**



**Electric Model
(PLE6014)**

ORDER INFORMATION

Capacity (Tons)	Stroke (in.)	Order Number	Retracted Height (in.)	Extended Ht. w/Extensions (in.)	Product Wt. Less Cribbing & Ext.
60	14	*PLE6014K	24	70	522
60	14	*PLA6014K	24	70	522
60	14	*PLE6014K-220	24	70	522
100	14	Consult Factory	24	59	522

*Includes cribbing block set stored on jack handle rack, and 7 extensions (1, 2, 3, 4, 5, 10, and 20 inches)

- PLE6014 = Jack, Electric, includes: Cart, Pump & Cylinder**
- PLE6014-220 = Jack, Electric (220 V.)**
- PLA6014 = Jack, Air, includes: Cart, Pump & Cylinder**
- CBS60 = Cribbing Block Set (5 cribbing blocks)**
- PL60EXT = Extension Set (Consists of 7 extensions)**

**CRIBBING BLOCKS
(CBS60, INCLUDED)**

Qty.	Height	Order Number
1	1 1/2"	351954
4	3"	351953

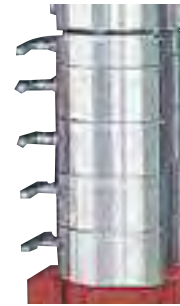

**EXTENSIONS
(PL60 EXT, INCLUDED)**

Extension Length (in.)	Order Number	Extension Weight (lbs.)
1	351931	4.9
2	351927	8.9
3	351928	14.1
4	351929	19.1
5	66053	20.9
10	66054	30.4
20	66055	48.6

LIFTING RANGE

Lifting range (in 1" increments):
24" - 70".

Only 3 extensions are needed
to provide this range.

Do NOT exceed 70" lifting
range on 60-ton unit or 59" on
100-ton unit.



JACKS

PORTABLE HIGH TONNAGE JACKS

55, 100 & 150 Ton

PORTABLE AND COMPACT, IDEAL FOR LOCOMOTIVE/RAILCAR, MINING AND HEAVY EQUIPMENT MAINTENANCE.



- Modular design - pump and cart separate from cylinder and base.
- Three tonnage capacity options - 55-ton, 100-ton and 150-ton.
- Three collapsed height options - 26", 33" and 45".
- Two standard power options - air (PA55) and electric (PE55).
- Two control options - remote motor control and remote valve/motor control.
- Accessory options - 6⁵/₈" extension, load-holding rings.
- Select the collapsed height to fit your most frequent application - add jacking modules to suit your needs.
- Remote operation for maximum operator safety and control - choose "motor only" or "motor and valve" control in the hand.
- Easy to maneuver - large tires and small "footprint" make it easy to scoot into the tightest quarters, then locate the exact lifting position.
- Adjustable, heavy-duty handle - makes this jack easy to move, position under vehicles. Can also be used to transport jack on site with a forklift.
- Load-holding rings (optional) - provide full rated mechanical load-holding capability.
- Shielded and sheltered hydraulic lines - for safer, longer, trouble-free service.
- Cylinder extension (optional) - adds more versatility by extending your jack's reach.
- Low-temperature oil (optional) - provides smooth, reliable operation in the coldest climate conditions.
- Modular design - allows you to change lifting modules to suit your tonnage or height requirements. Use the pump module as a portable power station for your other double-acting cylinders (10,000 psi).
- Exclusive load-control system - provides positive, chatter-free control when lowering the load.



ORDER INFORMATION

CRIBBING BLOCK SETS - INCLUDES ONE JACK MODULE EXTENSION

Order No.‡	55 Ton CBS55		100 Ton CBS100		150 Ton CBS150		200 Ton CBS200		300 Ton CBS300	
	No. in Set	1	4	1	4	1	4	1	4	
A	1 1/2"	3"	1 1/2"	3"	1 1/2"	3"	1 1/2"	3"		
B	1 3/4"	3 1/4"	1 3/4"	3 1/4"	1 3/4"	3 1/4"	1 3/4"	3 1/4"		
C	5 1/2"	5 1/2"	7 3/8"	7 3/8"	8 3/4"	8 3/4"	10"	10"		
Jack Module Ext.	6 13/16"		7"		6 5/8"		6 5/8"			
Total Stack Ht.	20 5/16"		20 1/2"		20 1/8"		20 1/8"			
Product Wt. (lbs.)	36		68		85		105			

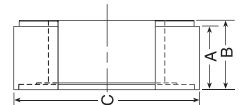

- Convert jack module into stable mechanical cribbing device.
- Increase retracted height up to 20 1/2 inches.

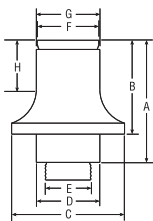

ORDER INFORMATION

JACK MODULE EXTENSIONS

		A	B	C	D	E	F	G	H	Prod. Wt.
(tons)	No.	(in.)	(in.)	(in.)	(in.)	(in.)	(in.)	(in.)	(in.)	(lbs.)
55	58945	8 13/16	6 13/16	5	2 5/8	1 11/16-8UN	2 1/2	2 5/8	3 5/8	21
100	58943	9	7	6 7/8	3 7/8	2 3/4-12UN	3 3/4	3 7/8	3 3/4	40
150	58944	8 5/8	6 5/8	8	4 1/2	3 1/4-8UNC	4 3/8	4 1/2	3 1/2	50

- Increases jack's reach.



Pump & cart modules

Pump and cart modules contain hydraulic pump, cart, remote control and all hoses and fittings required to connect to a jack module. Contact factory on folding handle cart option.

Remote Control		
Pump	Motor Only	Motor & Valve
Air	PMA55	PMA55S
Electric	PME55	PME55S
	PME355	PME355S
	PMA355	PMA355S

Jack modules

Jack modules easily separate from the pump and cart module.

Tonnage	Cylinder Stroke	Collapsed Height		
		26"	33"	45"
55	13 ¹ / ₈ "	JM25	JM35	JM45
100	13 ¹ / ₈ "	JM210	JM310	JM410
150	18 ¹ / ₈ "	JM215 [†]	JM315	JM415
200	18 ¹ / ₈ "	JM220 [*]	JM320	JM420
300	13 ¹ / ₈ "	JM230 ^{*†}	JM330 [†]	JM43 [†]

* collapsed height; 28 inches and stroke 13¹/₈ inches.

[†] stroke 13¹/₈ inches.

[†] Must use PM x355x versions of pump/cart modules above.



Air pump and cart module.



Electric pump and cart module.



26"

Jack Module



33"

Jack Module



45"

Jack Module

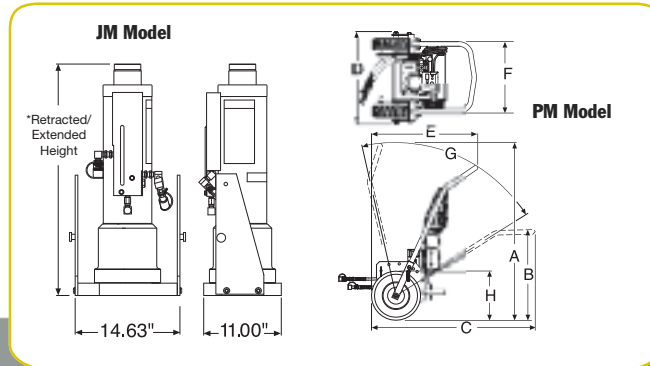

Dimensions

Model Series	A	B	C	D	E	F	G	H
PMA & PME	57 ⁵ / ₈ "	29 ⁵ / ₈ "	53 ¹ / ₄ "	30"	34 ⁵ / ₁₆ "	23 ³ / ₈ "	*70°	16" Tire Dia.

* Total range with varying degree increments.

ORDER INFORMATION – Pump and Cart Modules with Assembled Jack Module

Capacity (tons)	Ret. Height (in.)	Ext. Height (in.)	Stroke (in.)	Pump Type	Power Required	Valve Type	Remote Control	Order No.
55	26	39 ¹ / ₈	13 ¹ / ₈	Electric	25 amps	Manual	M	JEM5526
100	33	46 ¹ / ₈	13 ¹ / ₈	Air	50 CFM @ 80 psi	Manual	M	JAM10033
100	33	46 ¹ / ₈	13 ¹ / ₈	Air	50 CFM @ 80 psi	Air Pilot	M & V	JAR10033
150	26	39 ¹ / ₈	13 ¹ / ₈	Electric	25 amps	Manual	M	JEM15026
150	33	46 ¹ / ₈	13 ¹ / ₈	Air	50 CFM @ 80 psi	Manual	M	JAM15033



JACKS

HYDRAULIC & MECHANICAL TOOLS



TORQUE WRENCH ...166
Page
Square Drive



TORQUE WRENCH...168
Page
Low Clearance



PREDATOR AIR PUMP ...170
Page
Torque Wrench Pump



X1E1 & X1A1 TORQUE ...172
Page



PE30 SERIES...174
Page
Electric Torque Wrench Pump



PE55 TWP SERIES...175
Page
Electric Torque Wrench Pump



RWP55 SERIES...176
Page
Electric Torque Wrench Pump



NUT SPLITTER ...177
Page
Electric Torque Wrench Pump



FLANGE SPREADER ...178
Page
Electric Torque Wrench Pump



SPREADERS ...179
Page



C CLAMPS...180
Page



BEAD BREAKER...181
Page
Tire Removing Tool



PORTABLE PUNCHES...182
Page
HP20, HP35



TESTERS...184
Page



TESTERS SERVICE ACCESSORIES ...185
Page



RETAINING RING PLIERS...187
Page



SERVICE TOOLS...188
Page



WRENCHES & PRY BARS...189
Page



TORQUE WRENCH

Square Drive Predator Series

MAX TORQUE 33496 Nm 700 bar
24,705 Ft-Lb 10,152 PSI



360° SWIVEL



PREDATOR SERIES SQUARE DRIVE TORQUE WRENCHES

- Low Weight, High Strength Design
- Superior Torsional Strength
- Fast Operation Cycle
- Fine Tooth Pawl
- Floating Piston Design
- Internal Swivel Manifold Relief
- Rigid Steel Body Construction
- Compact Frame Size

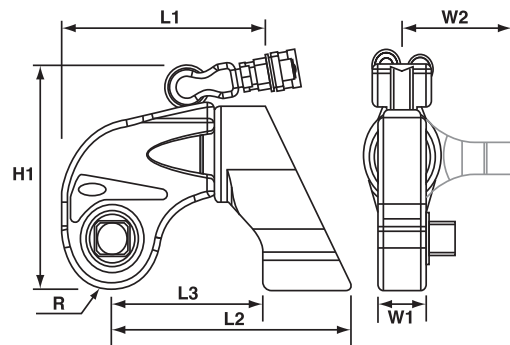

- Push Button Reversal of Square Drive
- Corrosion Resistant Finish
- 360° Reaction Arm
- Push to Click Reaction Arms
- Multi-Axis High Flow Swivel Manifold
- Simple Design
- Consistent Torque Output
- Fully Enclosed Drive Mechanism
- Accurate Torque Output
- Marathon Lifetime Warranty

Tool Model	L1		L2		L3		H1		R		W1		W2	
	(in.)	(mm)	(in.)	(mm)	(in.)	(mm)	(in.)	(mm)	(in.)	(mm)	(in.)	(mm)	(in.)	(mm)
TWSD1	5.5	139	6.7	170	4.4	112	5.7	145	1.1	28	1.3	33	3.4	86
TWSD3	6.7	170	7.7	196	4.9	124	6.9	175	1.5	38	1.8	46	4.1	104
TWSD6	7.7	196	9.3	236	5.6	142	8.1	206	1.8	46	2.0	51	5.4	137
TWSD11	9.2	234	11.5	292	7.0	178	9.5	241	2.2	56	2.4	61	6.5	165
TWSD25	12.0	305	14.8	376	9.1	231	12.4	315	2.8	71	3.0	76	7.9	200



Tool Model	Square Drive		Max. Torque		Tool Weight	
	(in.)	(mm)	(ft. lbs.)	(Nm)	(lbs.)	(kg)
TWSD1	3/4	19.0	1,390	1800	5.1	2.3
TWSD3	1	25.4	3,070	4160	9.9	4.5
TWSD6	1 1/2	38.1	6,020	8157	17.4	7.9
TWSD11	1 1/2	38.1	10,940	14823	28.9	13.1
TWSD25	2 1/2	63.5	24,700	33496	65.0	29.5

SQUARE DRIVE HEX DRIVES AND SOCKETS

Torque Wrench	Hexagon Drive Size A/F (in.)	Part No.	Hexagon Drive Size A/F (mm)	Part No.
TWSD1	0.63	TWD1-063	17mm	TWD1-017
	0.75	TWD1-075	19mm	TWD1-019
	0.88	TWD1-088	22mm	TWD1-022
	1.00	TWD1-100	24mm	TWD1-024
	-	-	27mm	TWD1-027
TWSD3	0.63	TWD3-063	17mm	TWD3-017
	0.75	TWD3-075	19mm	TWD3-019
	0.88	TWD3-088	22mm	TWD3-022
	1.00	TWD3-100	24mm	TWD3-024
	1.13	TWD3-113	27mm	TWD3-027
	1.25	TWD3-125	30mm	TWD3-030
	1.38	TWD3-138	32mm	TWD3-032
TWSD6	0.88	TWD6-088	22mm	TWD6-022
	1.00	TWD6-100	24mm	TWD6-024
	1.13	TWD6-113	27mm	TWD6-027
	1.25	TWD6-125	30mm	TWD6-030
	1.38	TWD6-138	32mm	TWD6-032
	1.50	TWD6-150	36mm	TWD6-036
TWSD11	1.63	TWD6-163	41mm	TWD6-041
	1.13	TWD11-113	27mm	TWD11-027
	1.25	TWD11-125	30mm	TWD11-030
	1.38	TWD11-138	32mm	TWD11-032
	1.50	TWD11-150	36mm	TWD11-036
TWSD25	1.63	TWD11-163	41mm	TWD11-041
	1.75	TWD11-175	46mm	TWD11-046
	1.50	TWD25-150	36mm	TWD25-036
	1.63	TWD25-163	41mm	TWD25-041
	1.75	TWD25-175	46mm	TWD25-046
	1.88	TWD25-188	50mm	TWD25-050
	2.00	TWD25-200	55mm	TWD25-055
	2.25	TWD25-225	60mm	TWD25-060
	2.50	TWD25-250	65mm	TWD25-065
	2.75	TWD25-275	70mm	TWD25-070



Socket Size in.	3/4" Drive Part No.	1" Drive Part No.	1-1/2" Drive Part No.	2-1/2" Drive Part No.	Socket Size mm	3/4" Drive Part No.	1" Drive Part No.	1-1/2" Drive Part No.	2-1/2" Drive Part No.
7/8	TWSIA088	TWSIB088	-	-	22	TWSMA022	TWSMB022	-	-
1-1/16	TWSIA106	TWSIB106	-	-	24	TWSMA024	TWSMB024	-	-
1-1/4	TWSIA125	TWSIB125	-	-	32	TWSMA032	TWSMB032	-	-
1-3/8	TWSIA138	TWSIB138	-	-	36	TWSMA036	TWSMB036	-	-
1-7/16	TWSIA144	TWSIB144	-	-	41	TWSMA041	TWSMB041	TWSMC041	-
1-5/8	TWSIA163	TWSIB163	TWSIC163	-	46	TWSMA046	TWSMB046	-	-
1-13/16	TWSIA181	TWSIB181	-	-	50	TWSMA050	TWSMB050	-	-
2	TWSIA200	TWSIB200	TWSIC200	-	55	-	TWSMB055	-	-
2-3/16	TWSIA219	TWSIB219	TWSIC219	-	60	-	TWSMB060	TWSMC060	-
2-3/8	TWSIA238	TWSIB238	TWSIC238	-	65	-	TWSMB065	TWSMC065	-
2-9/16	-	TWSIB256	TWSIC256	-	70	-	TWSMB070	TWSMC070	-
2-3/4	-	TWSIB275	TWSIC275	-	75	-	-	TWSMC075	-
2-15/16	-	TWSIB294	TWSIC294	-	80	-	TWSMB080	TWSMC080	TWSMF080
3-1/8	-	TWSIB313	TWSIC313	TWSIF313	85	-	TWSMB085	TWSMC085	TWSMF085
3-3/8	-	TWSIB338	TWSIC338	TWSIF338	90	-	TWSMB090	TWSMC090	TWSMF090
3-1/2	-	TWSIB350	TWSIC350	TWSIF350	95	-	TWSMB095	TWSMC095	TWSMF095
3-3/4	-	TWSIB375	TWSIC375	TWSIF375	100	-	TWSMB100	-	TWSMF100
3-7/8	-	TWSIB388	-	TWSIF388	110	-	TWSMB110	TWSMC110	TWSMF110
4-1/8	-	TWSIB413	TWSIC413	TWSIF413	115	-	-	TWSMC115	TWSMF115
4-1/4	-	TWSIB425	TWSIC425	TWSIF425	120	-	-	TWSMC120	-
4-5/8	-	-	TWSIC463	TWSIF463	135	-	-	-	TWSMF135
5	-	-	-	TWSIF500	150	-	-	-	TWSMF150
5-3/8	-	-	-	TWSIF538					
5-3/4	-	-	-	TWSIF575					
6-1/8	-	-	-	TWSIF613					



TORQUE WRENCH

Low Clearance Predator Series

MAX TORQUE 39,024 Nm 700 bar
28,782 Ft-Lb 10,000 PSI

THE LIGHTWEIGHT, HEAVY-DUTY TOOL FEATURES A LONG NECK, SHORT HEIGHT, AND SMALL RADIUS FOR INACCESSIBLE BOLTING AREAS FOUND IN INDUSTRY.

- Low Weight, High Strength Design
- Superior Torsional Strength
- Fast Operation Cycle
- Fine Tooth Pawl
- Floating Piston Design
- Auto-Connect Drive Piston
- Compact Frame Size
- Rigid Steel Body Construction
- Internal swivel manifold Relief
- Built-in Reaction Pad

PREDATOR LOW CLEARANCE TORQUE WRENCHES

The TWLC Predator Series Wrench was designed for the most inaccessible bolting areas found in industry. Its long neck, short height and small radius have all added to its great success



- Small Nose Radius
- Tool Free Link Change
- Corrosion Resistant Finish
- Multi-Axis High Flow Swivel Manifold
- Simple Design
- Consistent Torque Output
- Marathon Lifetime Warranty

* Links sold separately.
Tool is not shipped with link.

HOSES – DUAL LINE

TWH15	15', 1/4" ID non-conductive 4.6m, 9.5mm ID non-conductive
TWH20	20', 1/4" ID non-conductive 6m, 9.5mm ID non-conductive
TWH50	50', 1/4" ID non-conductive 15.2m, 9.5mm ID non-conductive

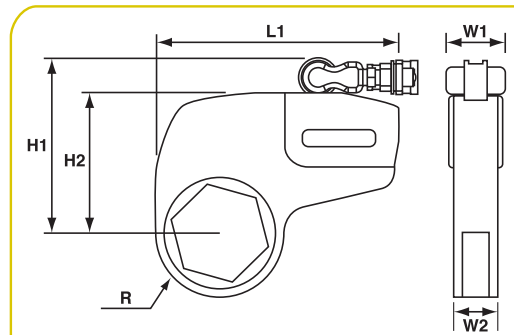

Tool Model	L1		H1		H2		R		W1		W2	
	(in.)	(mm)	(in.)	(mm)	(in.)	(mm)	(in.)	(mm)	(in.)	(mm)	(in.)	(mm)
TWLC2	7.6	193	5.4	137	4.1	104	1 1/4 - 1 7/8	32-48	1.7	43	1.3	33
TWLC4	8.8	223	6.4	163	5.1	130	1 1/2 - 1 7/8	38-47	2.0	51	1.7	43
TWLC8	10.4	264	7.7	196	6.2	158	2 - 2 7/8	51-74	2.7	69	2.1	53
TWLC15	12.0	305	8.8	224	7.3	185	2 3/8 - 2 1/2	60-64	3.1	79	2.5	64
TWLC30	15.4	391	10.9	277	9.4	239	3 - 4 1/2	76-114	4.2	107	3.2	81

Tool Model	Hex Range		Max. Torque		Tool Weight	
	(in.)	(mm)	(ft.)	(Nm)	(lbs)	(kg)
TWLC2	1 1/4 - 2 3/8	32 - 60	1,575	2,135	6.2	2.8
TWLC4	1 1/2 - 3 1/8	38.1 - 79	3,975	5,389	12.6	5.7
TWLC8	2 3/8 - 3 7/8	60 - 98	7,950	10,770	22.9	10.3
TWLC15	2 9/16 - 4 5/8	65 - 117	14,850	20,133	37.3	16.9
TWLC30	3 1/8 - 6 1/8	79 - 155	28,800	39,047	77.0	34.9





Tool	Link Part No.	Nut A/F		Reducer			Reducer			Reducer			
		in.	mm	in.	mm	Part No.	in.	mm	Part No.	in.	mm	Part No.	
TWLC2	TWL2-032	1.25	32	-	-	-	-	-	-	-	-	-	
	TWL2-036	1.44	36	-	-	-	-	-	-	-	-	-	
	TWL2-041	1.63	41	1.63-1.44	41-36mm	TWR2-041036	1.63-1.25	41-32mm	TWR2-041032	-	-	-	
	TWL2-046	1.81	46	1.81-1.63	46-41mm	TWR2-046041	1.81-1.44	46-36mm	TWR2-046036	1.81-1.25	46-32mm	TWR2-046032	
	TWL2-050	2.00	50	2.00-1.81	50-46mm	TWR2-050046	2.00-1.63	50-41mm	TWR2-050041	2.00-1.44	50-36mm	TWR2-050036	
	TWL2-055	2.19	55	2.19-2.00	55-50mm	TWR2-055050	2.19-1.81	55-46mm	TWR2-055046	2.19-1.63	55-41mm	TWR2-055041	
	TWL2-060	2.38	60	2.38-2.19	60-55mm	TWR2-060055	2.38-2.00	60-50mm	TWR2-060050	2.38-1.81	60-46mm	TWR2-060046	
TWLC4	TWL4-041	1.63	41	1.63-1.44	41-36mm	TWR4-041036	1.63-1.25	41-32mm	TWR4-041032	-	-	-	
	TWL4-046	1.81	46	1.81-1.63	46-41mm	TWR4-046041	1.81-1.44	46-36mm	TWR4-046036	1.81-1.25	46-32mm	TWR4-046032	
	TWL4-050	2.00	50	2.00-1.81	50-46mm	TWR4-050046	2.00-1.63	50-41mm	TWR4-050041	2.00-1.44	50-36mm	TWR4-050036	
	TWL4-055	2.19	55	2.19-2.00	55-50mm	TWR4-055050	2.19-1.81	55-46mm	TWR4-055046	2.19-1.63	55-41mm	TWR4-055041	
	TWL4-060	2.38	60	2.38-2.19	60-55mm	TWR4-060055	2.38-2.00	60-50mm	TWR4-060050	2.38-1.81	60-46mm	TWR4-060046	
	TWL4-065	2.56	65	2.56-2.38	65-60mm	TWR4-065060	2.56-2.19	65-55mm	TWR4-065055	2.56-2.00	65-50mm	TWR4-065050	
	TWL4-070	2.75	70	2.75-2.56	70-65mm	TWR4-070065	2.75-2.38	70-60mm	TWR4-070060	2.75-2.19	70-55mm	TWR4-070055	
	TWL4-075	2.94	75	2.94-2.75	75-70mm	TWR4-075070	2.94-2.56	75-65mm	TWR4-075065	2.94-2.38	75-60mm	TWR4-075060	
	TWL4-080	3.13	80	3.13-2.94	80-75mm	TWR4-080075	3.13-2.75	80-70mm	TWR4-080070	3.13-2.56	80-65mm	TWR4-080065	
TWLC8	TWL8-060	2.38	60	2.38-2.19	60-55mm	TWR8-060055	2.38-2.00	60-50mm	TWR8-060050	2.38-1.81	60-46mm	TWR8-060046	
	TWL8-065	2.56	65	2.56-2.38	65-60mm	TWR8-065060	2.56-2.19	65-55mm	TWR8-065055	2.56-2.00	65-50mm	TWR8-065050	
	TWL8-070	2.75	70	2.75-2.56	70-65mm	TWR8-070065	2.75-2.38	70-60mm	TWR8-070060	2.75-2.19	70-55mm	TWR8-070055	
	TWL8-075	2.94	75	2.94-2.75	75-70mm	TWR8-075070	2.94-2.56	75-65mm	TWR8-075065	2.94-2.38	75-60mm	TWR8-075060	
	TWL8-080	3.13	80	3.13-2.94	80-75mm	TWR8-080075	3.13-2.75	80-70mm	TWR8-080070	3.13-2.56	80-65mm	TWR8-080065	
	TWL8-085	3.38	85	3.38-3.13	85-80mm	TWR8-085080	3.38-2.94	85-75mm	TWR8-085075	3.38-2.75	85-70mm	TWR8-085070	
	TWL8-090	3.50	90	3.50-3.38	90-85mm	TWR8-090085	3.50-3.13	90-80mm	TWR8-090080	3.50-2.94	90-75mm	TWR8-090075	
	TWL8-095	3.75	95	3.75-3.50	95-90mm	TWR8-095090	3.75-3.38	95-85mm	TWR8-095085	3.75-3.13	95-80mm	TWR8-095080	
	TWL8-100	3.88	100	3.88-3.75	100-95mm	TWR8-100095	3.88-3.50	100-90mm	TWR8-100090	3.88-3.38	100-85mm	TWR8-100085	
	TWL8-105	-	105	-	105-100mm	TWR15-105100	-	105-95mm	TWR15-105095	-	105-90mm	TWR15-105090	
	TWL8-110	4.25	-	4.25-3.88	-	TWR15-425388	4.25-3.75	-	TWR15-425375	4.25-3.50	-	TWR15-425350	
TWLC15	TWL15-070	2.75	70	2.75-2.56	70-65mm	TWR15-070065	2.75-2.38	70-60mm	TWR15-070060	2.75-2.19	70-55mm	TWR15-070055	
	TWL15-075	2.94	75	2.94-2.75	75-70mm	TWR15-075070	2.94-2.56	75-65mm	TWR15-075065	2.94-2.38	75-60mm	TWR15-075060	
	TWL15-080	3.13	80	3.13-2.94	80-75mm	TWR15-080075	3.13-2.75	80-70mm	TWR15-080070	3.13-2.56	80-65mm	TWR15-080065	
	TWL15-085	3.38	85	3.38-3.13	85-80mm	TWR15-085080	3.38-2.94	85-75mm	TWR15-085075	3.38-2.75	85-70mm	TWR15-085070	
	TWL15-090	3.50	90	3.50-3.38	90-85mm	TWR15-090085	3.50-3.13	90-80mm	TWR15-090080	3.50-2.94	90-75mm	TWR15-090075	
	TWL15-095	3.75	95	3.75-3.50	95-90mm	TWR15-095090	3.75-3.38	95-85mm	TWR15-095085	3.75-3.13	95-80mm	TWR15-095080	
	TWL15-100	3.88	100	3.88-3.75	100-95mm	TWR15-100095	3.88-3.50	100-90mm	TWR15-100090	3.88-3.38	100-85mm	TWR15-100085	
	TWL15-105	-	105	-	105-100mm	TWR15-105100	-	105-95mm	TWR15-105095	-	105-90mm	TWR15-105090	
	TWL15-110	-	110	-	110-105mm	TWR15-110105	-	110-100mm	TWR15-110100	-	110-95mm	TWR15-110095	
	TWL15-115	-	115	-	115-110mm	TWR15-115110	-	115-105mm	TWR15-115105	-	115-100mm	TWR15-115100	
	TWL15-463	4.63	-	4.63-4.25	-	TWR15-463425	4.63-3.88	-	TWR15-463388	4.63-3.75	-	TWR15-463375	
	TWLC30	TWL30-080	3.13	80	3.13-2.94	80-75mm	TWR30-080075	3.13-2.75	80-70mm	TWR30-080070	3.13-2.56	80-65mm	TWR30-080065
		TWL30-085	3.38	85	3.38-3.13	85-80mm	TWR30-085080	3.38-2.94	85-75mm	TWR30-085075	3.38-2.75	85-70mm	TWR30-085070
TWL30-090		3.50	90	3.50-3.38	90-85mm	TWR30-090085	3.50-3.13	90-80mm	TWR30-090080	3.50-2.94	90-75mm	TWR30-090075	
TWL30-095		3.75	95	3.75-3.50	95-90mm	TWR30-095090	3.75-3.38	95-85mm	TWR30-095085	3.75-3.13	95-80mm	TWR30-095080	
TWL30-100		3.88	100	3.88-3.75	100-95mm	TWR30-100095	3.88-3.50	100-90mm	TWR30-100090	3.88-3.38	100-85mm	TWR30-100085	
TWL30-105		-	105	-	105-100mm	TWR30-105100	-	105-95mm	TWR30-105095	-	105-90mm	TWR30-105090	
TWL30-425		4.25	-	4.25-3.88	-	TWR30-425388	4.25-3.75	-	TWR30-425375	4.25-3.50	-	TWR30-425350	
TWL30-110		-	110	-	110-105mm	TWR30-110105	-	110-100mm	TWR30-110100	-	110-95mm	TWR30-110095	
TWL30-115		-	115	-	115-110mm	TWR30-115110	-	115-105mm	TWR30-115105	-	115-100mm	TWR30-115100	
TWL30-463		4.63	-	4.63-4.25	-	TWR30-463425	4.63-3.88	-	TWR30-463388	4.63-3.75	-	TWR30-463375	
TWL30-120		-	120	-	120-115mm	TWR30-120115	-	120-110mm	TWR30-120110	-	120-105mm	TWR30-120105	
TWL30-500		5.00	-	5.00-4.63	-	TWR30-500463	5.00-4.25	-	TWR30-500425	5.00-3.88	-	TWR30-500388	
TWL30-130		-	130	-	130-120mm	TWR30-130120	-	130-115mm	TWR30-130115	-	130-110mm	TWR30-130110	
TWL30-135		5.38	135	5.38-5.00	135-125mm	TWR30-135125	5.38-4.63	135-120mm	TWR30-135120	5.38-4.25	135-115mm	TWR30-135115	
TWL30-145		5.75	145	-	-	-	-	-	-	-	-	-	
TWL30-150	-	150	-	-	-	-	-	-	-	-	-		
TWL30-155	6.13	155	-	-	-	-	-	-	-	-	-		

AVAILABLE UPON REQUEST

HYDRAULIC TOOLS



TORQUE WRENCH PUMPS

Hydraulic/Air Predator Series

**CONSTANT HORSEPOWER
PUMP OR HORSEPOWER
LIMITING PUMP. QUALITY
ENGINEERED AND PRECISION-
MACHINED USING STRONG
LIGHTWEIGHT ALLOYS.**

PREDATOR SERIES HYDRAULIC AIR PUMPS

The new Predator Series air pumps are the first constant horsepower pump or horsepower limiting pump in the portable hydraulic pump market.

What can torque wrench users expect? In a word..... SPEED.

A few advantages of the Predator Series Pumps:

- Up to twice the tool speed of typical 2-speed pumps
- Continuous Duty Operation
- External Pressure Adjustment
- Four Tool Manifold (Optional)
- Calibratable Gauge
- Roll Bar (Optional)
- Sealed Hydraulic Reservoir
- Modular Pumping Cartridges
- 1,500 psi/103 Bar Return Side Relief Protection
- Exhaust air heat exchanger-built in
- FRL included
- Quiet operation



CAUTION: This Pump should not be used for lifting applications

Patent Pending

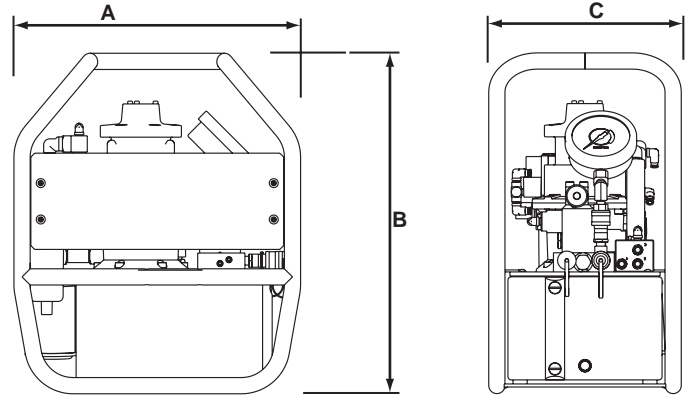

Tool Model.	Required Air Pressure	Max. Pressure Output	RPM	dBa at Idle & 700 bar	Reservoir Usable				A Height	B Width	C Length	Product Weight (w/oil)	
					48 bar	172 bar	350 bar	700 bar					
PCHA60T3B0-C	1,4 m ³ /min @ 6 bar	700 bar	3,000	75	19.8 L/min.	7.6 L/min.	3.6 L/min.	2 L/min.	3.8L	505mm	257mm	711mm	36.3kg
	50cfm/ @ 80psi	10,000 psi	3,000	75	1,240 in. ³ /min.	475 in. ³ /min.	220 in. ³ /min.	120 in. ³ /min.		19.88"	10.13"	28.00"	80 lbs

- Continuously variable performance curve offers maximum flow throughout the pressure range for greater productivity
- Designed for heavy-duty, extended cycle operation
- Internal oil path warms exhaust air to avoid freezing while cooling hydraulic oil to achieve optimum oil temperature
- ATEX II, CAT2, GDcT4 Compliant enables application in potentially explosive environments
- FRL Air Preparation Serviceable filter, regulator, lubricator ensures clean, lubricated & consistent air supply

- Easy operator adjustment to achieve corresponding torque values
- 1,500 psi/103 Bar Return Side Relief protection standard protection for return side of tool
- Marathon Lifetime Warranty Offers protection against defects in workmanship & material

 **CAUTION: This Pump should not be used for lifting applications**

**Pneumatic remote control
25 ft. cord standard**

**Calibratable, vibration damped
gauge easy to read 4" diameter,
10,000 psi/700 bar**



**Powerful 4 HP air motor
starts under load & yields up to twice
the flow of other air pumps for greater
application speed & productivity**

**Easily replaceable pump cartridges
minimize downtime & service costs**

**Muffled exhaust protects against elevated
noise to ensure operator comfort**

**Four-tool manifold option en-
ables application of up to four
torque wrenches for greater
worksite productivity**

**Optional roll bar design offers
protection from damage**

The above chart shows a traditional two stage hydraulic pump flow curve where high flow transitions to low flow at around 700 psi. The chart also shows that the Predator Series pump has much higher flow and flow remains smooth throughout the pressure curve. Flow is continually changing based on pressure, giving the maximum horsepower and flow for that pressure. The biggest increase in flow is between 1,000 & 5,000 psi.

For tools such as torque wrenches that normally operate between 1,000 & 5,000 psi, the impact is significant – tools operate twice as fast, increasing productivity or getting the job done in much less time.

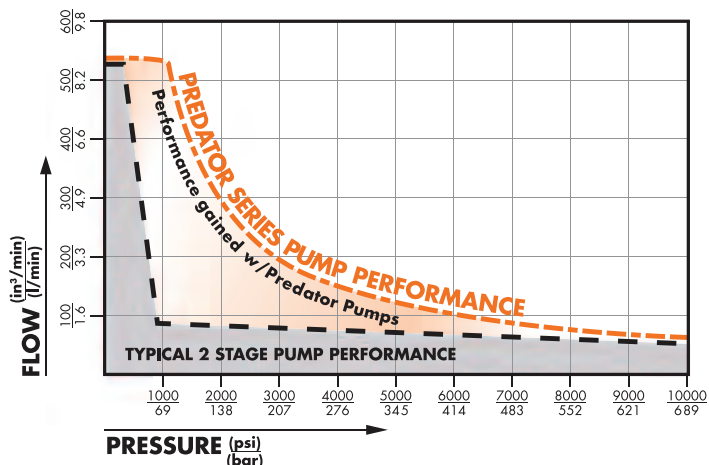

TORQUE WRENCH

Electric Pumps

X1E1-PT

700 bar



**ELECTRIC 115V 60HZ
TORQUE WRENCH PUMPS**

**THE POWER TEAM X1E1-PT:
SOLD FOR YEARS TO END CUSTOMERS.**



CAUTION: This Pump should not be used for lifting applications

FEATURES BENEFITS

- Base pump unit, Power Team PE55 series – the standard in the industry
- Two-speed high performance pump
- Retract side internal relief-valve protects tool
- 4-way 2-position solenoid valve standard
- Utilizes rugged electrical controls
- External adjustable pressure regulator
- Hand remote standard
- For single or double-acting tools

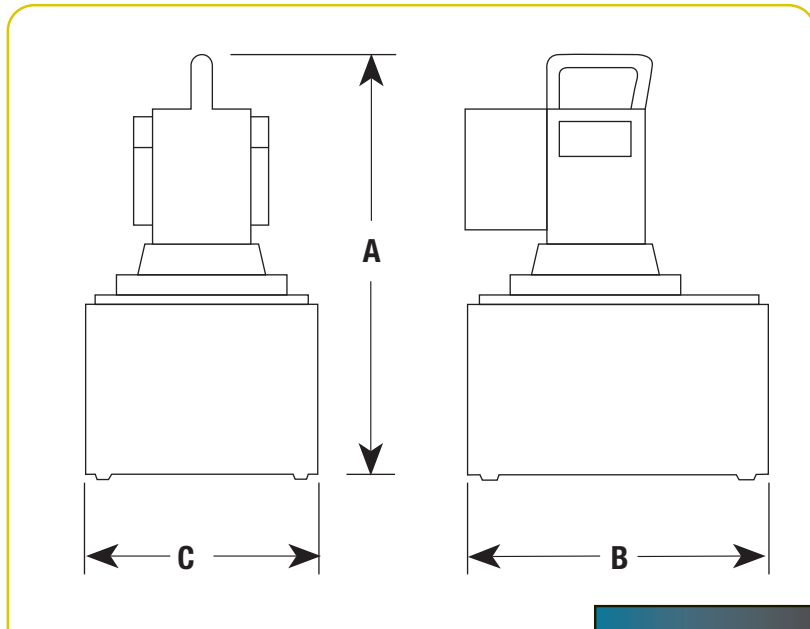

Pump Number	Description	Oil Delivery	Oil Reservoir	Weight	A	B	C
X1E1-PT	Electric-Powered Torque Wrench Pump	55 in ³ @10,000 PSI	2.5 Gal	72.8 lbs.	18	13	13 ⁷ / ₈

TORQUE WRENCH

Air Pumps

X1A1-PT

700 bar



CAUTION: This Pump should not be used for lifting applications



**AIR-POWERED
TORQUE WRENCH PUMPS**

X1A1-PT FEATURES THE SAME RUGGED TIME-PROVEN DESIGN AS THE POWER TEAM X1E1-PT

- Base pump unit, Power Team PA55 series – the standard in the industry
- Two-speed high performance pump
- Retract side internal relief-valve protects tool
- 4-way 2-position air valve standard
- External adjustable pressure regulator
- Hand remote standard

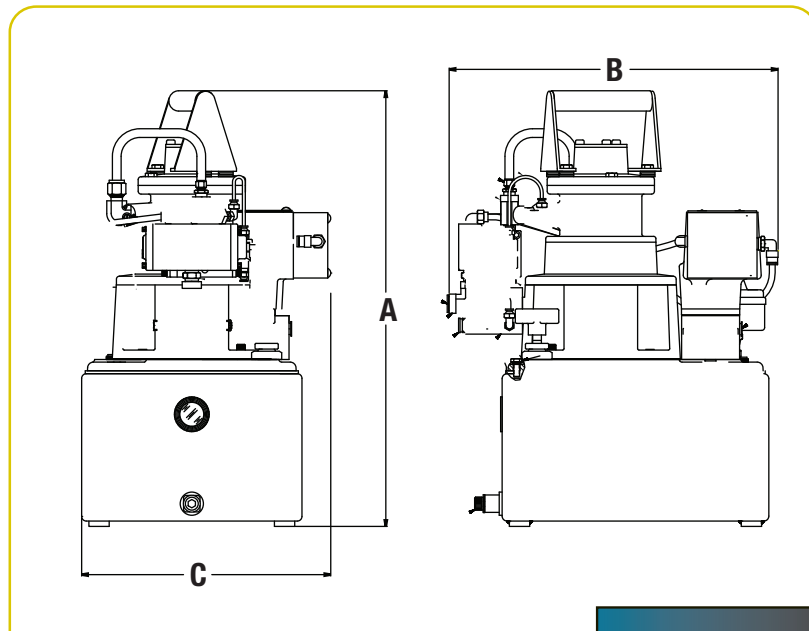

HYDRAULIC TOOLS



Pump Number	Description	Oil Delivery in ³	Oil Reservoir	Weight	A	B	C
X1A1-PT	Air-Powered Torque Wrench Pump	55	2.5 Gallon	75	18 ³ / ₄	18	10 ³ / ₄

TORQUE WRENCH PUMP

Hydraulic/Electric
PE30 Series

300 CU. IN./MIN MAX FLOW 10,000 PSI

VANGUARD® ELECTRIC HYDRAULIC TORQUE WRENCH PUMPS

- Two-speed general duty pump
- External adjustable pressure regulator
- Retract side internal relief valve protects tool
- Hand remote
- Use for double or single acting tools

CAUTION: This system should not be used for lifting applications.



Pump Model	Oil Delivery per min.	Oil Reservoir gal.	Usable Oil in. ³	Overall Width in.	Overall Length in.	Overall Height in.	Pump Weight w/Oil lbs.
PE30TWP							
PE30TWP-E110*	300 in ³ @ 100 psi						
PE30TWP-E220*	30 in ³ @ 10,000 psi	1.25	280	13.82	13.13	16.62	68

	Electric Motor	Electrical Data	Electrical Control
		4,000 rpm	
PE30TWP	1hp, 115V/60Hz, 13 amps		
PE30TWP-E220	220V/50Hz, 7 amps		
PE30TWP-E110	110V/50Hz, 13 amps		

*CE Approved - designed for 50 Hz applications

TORQUE WRENCH PUMP

Hydraulic/Electric
PE55 Series

VANGUARD® ELECTRIC HYDRAULIC TORQUE WRENCH PUMPS

- Two-speed high performance pump
- External adjustable pressure regulator
- Retract side internal relief valve protects tool
- Hand remote
- Use for double or single acting tools
- Four-tool manifold (-4 model only) allows use of up to four tools simultaneously

**704 CU. IN/MIN
10,000 PSI**



PE55TWP



PE55TWP-4

CAUTION: This system should not be used for lifting applications.

Pump Model	Oil Delivery per min.	Oil Reservoir gal.	Usable Oil in.3	Overall Width in.	Overall Length in.	Overall Height in.	Pump Weight w/Oil lbs.
PE55TWP							
PE55TWP-E110*	704 in ³ @ 0 psi	2.5	525	17.14	9.5	18.12	75
PE55TWP-E220*	56 in ³ @ 10,000 psi						
PE55TWP-4							
PE55TWP-4-E110*	704 in ³ @ 0 psi	2.5	525	18.49	9.5	19.15	78
PE55TWP-4-E220*	56 in ³ @ 10,000 psi						
X1E1-PT (Electric)							

	Electrical Data	
	Electric Motor	Electrical Control
PE55TWP	1-1/8 hp, 12000 rpm 115V, 25 amps	Remote control with 20-foot cord
PE55TWP-E110*	110V/50Hz, 25 amps	
PE55TWP-E220*	220V/50Hz, 13 amps	

* CE Approved-designed for 50Hz. applications.



TORQUE WRENCH PUMP

Air/Hydraulic
PA55 SERIES

AIR HYDRAULIC TORQUE WRENCH PUMP

- Use where air is the preferred source of power
- Powerful 3 hp motor starts under load
- External adjustable pressure regulator
- Retract side internal relief valve protects tool
- Use for double or single acting tools

**MAX FLOW 465 CU.
IN./MIN. 10,000 PSI**

**COUPLERS
INCLUDED
WITH PUMP**

⚠ CAUTION: This system should not be used for lifting applications.



Pump Model	Oil Delivery per min.	Oil Reservoir gal.	Usable Oil in. ³	Overall Width in.	Overall Length in.	Overall Height in.	Pump Weight w/Oil lbs.
RWP55	465 in ³ @ 100 psi 55in ³ @ 10,000 psi	2.5	590	16.55	9.5	19.83	76
RWP55-4 (4-tool manifold)	465 in ³ @ 100 psi 55in ³ @ 10,000 psi	2.5	590	16.55	9.5	19.83	76



HYDRAULIC TOOLS

Air Motor	Motor Data	Air Control
3 hp, 50 cfm @ 80 psi		Pneumatic remote control with 25-foot cord

NUT SPLITTERS

Hydraulic
15 & 25 Ton Capacity

HYDRAULIC NUT SPLITTERS – 15- & 25-TON CAPACITY

- “Dial-in” feature on HNS150 makes adjustment of splitter simple, without the worry of damaging the bolt
- Specially designed “tool steel” cutter blade penetrates the nut to the precise point where it cracks, stopping short of the bolt threads
- Nut splitter features a dramatically improved cutter blade with an 800% greater resistance to chipping and breaking over previous models

- All models feature a rugged one-piece cutting frame coupled to a heavy-duty hydraulic cylinder
- Compact size allows you to use it in confined areas where it will deliver enough force to split the toughest “fused” or rusted-on grade 2H nuts
- Simply split nut on one side, spin nut splitter 1/2 turn and make second cut on opposite side; nut separates into halves for easy removal



HNS150



HNS225



Align mark on
cutter blade
with scale.

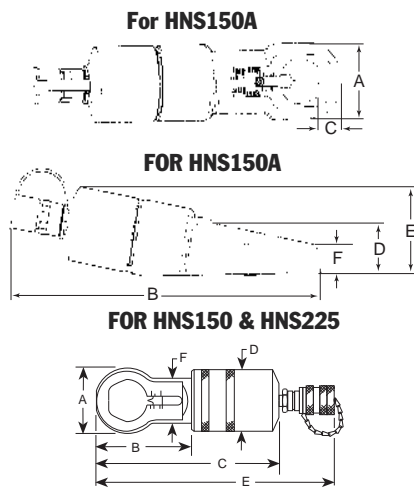

FOR HNS150 & HNS225

Tool Model	A	B	C	D	E	F	HEAD THICKNESS	REPLACEMENT BLADE	TOOL WEIGHT
HNS150	2.875	3.375	7.875	2.75	10.375	2.0625	1	308840	8.1
HNS150A	3.02	14.20	1.03	2.11	3.70	1.16	1	351985	15.8
HNS225	4.25	6	14.375	3.875	N/A	3.25	1.5	308022	29

HYDRAULIC TOOLS



CAPACITIES

Tool Model	2 or A	Nut Grade 5 or B	8 or C	2H
HNS150	1/2 - 1-1/2 in. hex	1/2 - 1-1/2 in. hex	1/2 - 1-5/16 in. hex	1/2 - 1-1/8 in. hex
HNS150A	1/2 - 1-1/2 in. hex	1/2 - 1-1/2 in. hex	1/2 - 1-5/16 in. hex	1/2 - 1-1/8 in. hex
HNS225	1-1/8 - 2-1/4 in. hex	1-1/8 - 2-1/4 in. hex	1-1/8 - 2-1/16 in. hex	1-1/8 - 1-11/16 in. hex

PIPE FLANGE

Hydraulic Spreaders

5 & 10 Ton



HFS3A

- You'll never again have to resort to "hammer and chisel" methods that waste time and effort. Flange spreaders should be used in pairs to provide even spreading force.
- Standard 60° wedge is suitable for most flanges; 30° "thin" and 60° "blunt" wedges are optional.
- The HFS3A is designed for applications where total thickness of flanges and max. spread gap is 3" or less and flange bolts are a min. of $1\frac{1}{16}$ " dia.
- Use HFS6A if total thickness of flanges and max. spread gap is 6" or less, and flange bolts are a min. of $1\frac{3}{16}$ " dia.



350823



350822



350549



350550

Capacity (tons)	Order Number	Standard Wedge Type	Optional Wedges		Min. Flange Opening			Max. Flange Opening			Min. Combined Flange Opening	Pin Dia. (in.)	Weight (lbs.)
			30° Thin	60° Blunt	60° Std.	60° Blunt	30°	60° Std.	60° Blunt	30°			
5	HFS3A	60° Sharp	350823	350822	$\frac{1}{16}$ "	1"	$\frac{3}{16}$ "	$1\frac{1}{4}$ "	$1\frac{1}{4}$ "	$\frac{23}{32}$ "	3 $\frac{1}{2}$ "	$\frac{11}{16}$ "	9
10	HFS6A	60° Sharp	350549	350550	$\frac{1}{16}$ "	1 $\frac{1}{2}$ "	$\frac{3}{16}$ "	2"	2"	$\frac{31}{32}$ "	6 $\frac{9}{16}$ "	$\frac{13}{16}$ "	18

SPREADERS

Hydraulic
1-1¹/₂ Ton



HS2000
(Forged Steel)

THE HYDRAULIC PRY BAR!

- Use to lift machines or as a clamp; spread concrete forms or rebar or perform straightening jobs.
- Conforms to ASME B30.1 standard.
- High strength alloy steel forged upper and lower jaws on HS2000.
- Jaws are spring-return; retract automatically when pressure is released.

No. HS2000 – 1-ton capacity spreader. Full 2,000 lbs. capacity at 10,000 psi. with 4" spread. Can be "dead-ended" at 4"

spread under full load. Needs only ⁹/₁₆" clearance to engage jaws.

No. HS3000 – 1¹/₂-ton capacity spreader. Full 3,000 lb. capacity at 10,000 psi. with 11¹/₂" spread. Greater than competitive units. Needs only 1³/₁₆" clearance to engage jaws. Can be "dead-ended" at 11¹/₂" spread at full load.

HS3000
(High Grade Ductile Iron)



Tested to conform to ASME B30.1 standard

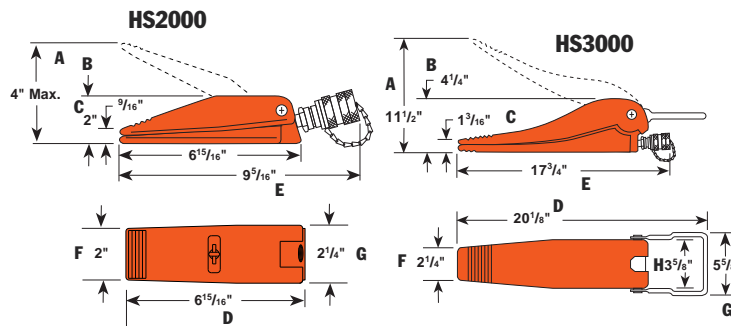

1	4	HS2000	4	2	⁹ / ₁₆ "	6 ¹⁵ / ₁₆ "	9 ⁵ / ₁₆ "	2	2 ¹ / ₄ "	—	.63	⁹ / ₁₆ "	4.8
1 ¹ / ₂	11 ¹ / ₂	HS3000	11 ¹ / ₂	4 ¹ / ₄	1 ³ / ₁₆ "	20 ⁷ / ₈ "	17 ³ / ₄ "	2 ¹ / ₄ "	5 ⁵ / ₈ "	3 ⁵ / ₈ "	3.5	1 ¹ / ₄ "	22

HS2000 SPECIFICATIONS

Maximum rated capacity....1 ton @ 10,000 psi
 Maximum spread4"
 Minimum clearance required⁹/₁₆"
 Cu. in. oil required63

HS3000 SPECIFICATIONS

Maximum rated capacity... 1¹/₂-ton @ 10,000 psi
 Maximum spread..... 11¹/₂"
 Minimum clearance required1³/₁₆"
 Cu. in. oil required 3.50

HYDRAULIC TOOLS



C-CLAMPS

Hydraulic Accessories

- In 5, 10 and 25 ton capacities. For use with Power Team general purpose single-acting series cylinders of comparable capacity.
- For clamping, pressing and bending. Ideal for welding and metal fabrication for fit-up of sheet or plate steel.
- Clamps withstand full rated capacity of the cylinders for which they are intended.
- To minimize the effects of off-center loading, the CC5, CC10 and CC25 should be used with the optional 350144 and 350145 swivel caps.



CC10

"C" CLAMPS 5, 10 & 25 TONS

Items pictured are:
CC10
C104C
201923

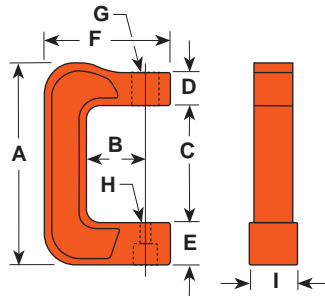

A (in.)	B (in.)	C (in.)	D (in.)	E (in.)	F (in.)	G (in.)	H (in.)	I (in.)	Weight (lb.)	Cap. (tons)	Order Number (C-Clamp only)	Use With Cyl. No.
12 ³ / ₈	3 ³ / ₄	7 ⁵ / ₁₆	2	2 ¹ / ₂	7 ³ / ₄	1 ¹ / ₂ "-16 UN	7/ ₈	3	25	5	CC5	C51C-C57C
15 ⁷ / ₈	6	9 ¹³ / ₁₆	2	3	10 ³ / ₄	2 ¹ / ₄ "-14 UNS	7/ ₈	3 ¹ / ₂	50	10	CC10	C101C-C1010C
21	6	13	3	4	12 ⁵ / ₁₆	3 ⁹ / ₁₆ "-12 UNS	1 ⁷ / ₁₆	4 ⁵ / ₈	65	25	CC25	C251C-C2514C

OPTIONAL ACCESSORIES FOR USE WITH CC5, CC10 & CC25 HYDRAULIC CLAMPS

Swivel Caps

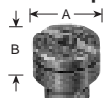

5/10 ton
350144*
A-1³/₈"
B-3³/₄"

25 ton
350145
A-2"
B-1"

Threaded Adapters

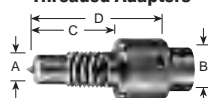

10 ton
38597
A-1 - 8
B-1 - 8
C-3³/₄"
D-2"

25 ton
38953
A-1¹/₄-7
B-1¹/₂-16
C-2³/₄"
D-4³/₈"

Pushing Adapters

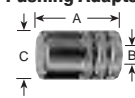

10 ton
28228**
A-2³/₈"
B-1 - 8
C-1¹/₂"

25 ton
28229**
A-2⁷/₈"
B-1¹/₄-7
C-1³/₄"

Pushing Adapters

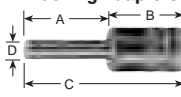

10 ton
201923**
A-3¹/₄"
B-2¹/₄"
C-5³/₈"
D-1¹/₂"
E-1 - 8

25 ton
34510**
A-3¹/₄"
B-2⁵/₈"
C-5⁷/₈"
D-3³/₄"
E-1¹/₄-7

Pushing Adapters

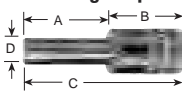

10 ton
201454**
A-3¹/₁₆"
B-2⁵/₈"
C-5¹/₁₆"
D-3³/₄"
E-1 - 8

25 ton
34511**
A-3¹/₄"
B-2³/₈"
C-5¹/₈"
D-1"
E-1¹/₄-7

V Pushing Adapters

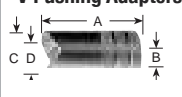

10 ton
34806**
A-2⁵/₈"
B-1 - 8
C-1¹/₂"
D-1"

25 ton
34807**
A-3¹/₈"
B-1¹/₄-7
C-1³/₄"
D-1¹/₄"

Pushing Adapters

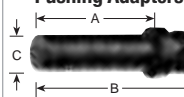

5 ton
309874*
A-2¹/₃₂"
B-2²⁵/₃₂"
C-5⁵/₈"

* May be used with CC5
** Must be used with a threaded adapter.



HYDRAULIC TOOLS

TIRE REMOVING

BB Series tool

10 Ton Hydraulic

TIRE REMOVING TOOL

- Made to fit into the pry bar pocket
- Hydraulic pressure does all the unseating.
- Lightweight and portable.
- P55 hydraulic hand pump and 9764 hose recommended to be used with BB1600.



HYDRAULIC TOOLS



Tool Model	Tool Weight lbs.	Rim Size	Cylinder Capacity (@10,000)	Stroke (in.)
BB1600	22.5	25"-49"	11.2	4
BB1601	24	25"-49"	11.2	4
		Single, two, three piece rims		

HYDRAULIC PUNCHES

20 & 35 Ton



HP35

REFER TO PAGE 227 FOR PUNCH INFORMATION

- Punch smooth, precise holes in seconds; much faster than drilling.
- Fully portable for construction, maintenance and service applications, or can be mounted on a workbench for production jobs. Has carrying handle for precise locating.
- Rugged, forged steel “C” frame for great strength and durability.
- Dual action, spring loaded stripper holds material during punching operation, strips material from punch on return. Scribe lines on stripper aid in locating the punch (HP 35 only).

- Double Acting prevents binding and speeds retraction (HP20 only).
 - **The PE172** electric/hydraulic pump is an ideal power source.
- No. HP35** – Punch only, includes metal case and die change tools. Wt., 42.5 lbs.
- No. HP35S** – Punch with punches and dies. Includes HP35 punch, metal case and 250459 punch/die set. Wt., 44 lbs.
- No. HP35P** – Punch set with pump. Same as HP35SP but does not include punch/die set. Wt., 86.3 lbs. NOTE: Available in 220 volt, 50 Hz. Order with suffix “-220”.

- No. HP35SP** – Punch set with pump. Includes HP35 punch, PE172 electric/hydraulic pump, 9756 hose, 9798 hose half coupler, 250459 punch/die set, metal case. Wt., 87.8 lbs. NOTE: 220 volt, 50 Hz. Order with suffix “-220”.
- No. 250459** – Punch/die set for round holes. Includes one each: PD437 $\frac{7}{16}$ " punch/die, PD562 $\frac{9}{16}$ " punch/die, PD688 $\frac{11}{16}$ " punch/die, PD812 $\frac{13}{16}$ " punch/die. Wt., 1.5 lbs.

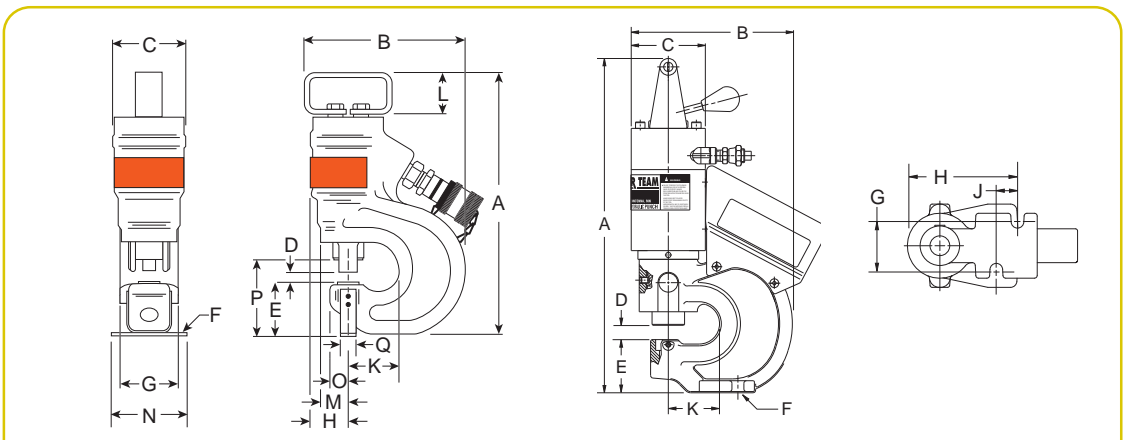

Cap.	Order Number	Max. Oper. Press.	Max. Oil Cap.	Max. Material Thickness	Mtng. Holes																
					A (in.)	B (in.)	C (in.)	D (in.)	E (in.)	F (in.)	G (in.)	H (in.)	J (in.)	K (in.)	L (in.)	M (in.)	N (in.)	O (in.)	P (in.)	Q (in.)	
20	HP20	10,000 psi	3.9 cu.in.	$\frac{1}{2}$	$16\frac{1}{2}$	$7\frac{61}{64}$	$3\frac{21}{32}$	$\frac{5}{8}$	$2\frac{19}{32}$	$\frac{9}{16}$	$2\frac{1}{8}$	$4\frac{7}{8}$	$1\frac{5}{16}$	$2\frac{1}{4}$	—	—	—	—	—	—	
35	HP35	10,000 psi	4.6 cu.in.	$\frac{1}{2}$	$13\frac{3}{4}$	9	$3\frac{3}{4}$	$\frac{9}{16}$	$2\frac{7}{8}$	$\frac{1}{4}$	3	$1\frac{13}{16}$	—	$2\frac{13}{16}$	$2\frac{1}{4}$	$1\frac{1}{2}$	$3\frac{1}{2}$	$\frac{7}{8}$	4	$\frac{3}{4}$	

No. HP20 – Basic punch. Wt., 33 lbs.

No. HP20S – Punch frame with cylinder, valve, handle, two coupling nuts, plus five punch and die sets in 1/4", 5/16", 3/8", 7/16", and 17/32" dia. Wt., 35 lbs.

No. HP20SP* – Complete punch set with PE102A pump (115V, 50/60 Hz), 9682 nipple, two 9792 female couplers and two 9793 male couplers. Also includes two 9758 10' hoses, 9680 coupling, and same punch and die sets as in HP20S (above). Tool is completely assembled and pre-filled with oil. In storage box. Wt., 83 lbs.



HP20



Punch Set HP20SP
Includes the PE102A pump, hoses, couplers, punch and die sets in sizes 1/4", 5/16", 3/8", 7/16", and 17/32" diameter, with storage box.



Flat Die

Coupling Nut

Punch

PUNCH/DIE SETS FOR HP20 & HP35 HYDRAULIC PUNCHES

For use with HP20 Hydraulic Punch

For use with HP35 Hyd. Punch

Punch Size (in.)	Punch Style	Punch No.	Flat Die No.	Bevel Die No.	Coupling Nut No.	Punch/w Flat Die Set	Punch/w Bevel Die Set	Punch Size (in.)	INCHES		MM	
									Hole Dia.	Bolt	Hole Dia.	Bolt
1/4	○ Round	251970	251983	—	252001	—	—	1/4	1/4	#10	6.3	—
5/16		251971	251984	—	252001	PD313	—	5/16	5/16	1/4	7.9	—
3/8		251972	251985	251996	252001	PD375	PD375B	3/8	3/8	5/16	9.5	M8
7/16		251973	251986	251997	252001	PD437	PD437B	7/16	7/16	3/8	11.2	M10
17/32		251974	251987	251998	252001	PD531	PD531B	17/32	17/32	7/16	13.5	M12
9/16		251975	251988	251999	252001	PD562	PD562B	9/16	9/16	1/2	14.3	—
11/16		251976	251989	—	252001	PD688	—	11/16	11/16	5/8	17.5	M16
25/32		251977	251990	—	252002	PD781	—	25/32	25/32	—	19.8	M18
13/16		251978	251991	—	252002	PD812	—	13/16	13/16	3/4	20.6	—
1/2	□ Square	251979	251992	—	252002	—	—	—	—	—	—	—
17/32		251980	251993	—	252002	—	—	—	—	—	—	—
1/4 X 3/4	○ Obround	251981	251994	—	252002	—	—	—	—	—	—	—
3/8 X 3/4		251982	251995	—	252002	—	—	—	—	—	—	—

TYPICAL 20 TON STYLE TOOLING

HYDRAULIC TOOLS



ACCESSORIES FOR HP20 HYDRAULIC PUNCH

No. HP20FS – Optional foot switch mounted in foot switch guard. Supplied with 10 foot cord and male remote connector. Wt., 2 lbs.

No. HP20HS – Optional handswitch. Supplied with 10 foot cord and male remote connector. Wt., 2 lbs.

No. 252000 – Optional coupling nut wrench. Makes punch/die changes easier without “rounding-off” coupling nuts. Wt., 0.5 lbs.

TESTERS

Hydraulic

50, 75 & 200 GPM



HT50A



HT200

50-, 75- AND 200-GPM IN-LINE HYDRAULIC TESTERS

- Accurately measure oil flow, pressure and temperature on in-plant equipment, forklifts, machine tools and more.
- Temperature and flow readings are in Metric and English, accurate to within $\pm 2\%$ of full scale.
- Dual pressure gauges for high and low pressure readings; low pressure gauge is automatically shut off and protected as pressure rises beyond its maximum reading.
- Automatic pressure compensating

feature lets you increase flow without affecting pressure setting.

- Reverse flow through tester will not cause damage; replaceable safety disc ruptures if pressure exceeds upper limit.
- Solid state voltage regulator eliminates errors caused by voltage change during testing.

50-, 75- AND 200-GPM IN-LINE HYDRAULIC TESTERS

- Troubleshoots systems with capacities to 200 gpm at pressures less than 5,000 psi. Accurately measure oil flow

to $\pm 5\%$, pressure to within 2% and temperature readings within 1%.

- Pressure gauge is liquid filled to dampen system pulsation.

For more precise low pressure readings, an optional dual pressure gauge kit is available (see page 185).

No. HT50A – Hydraulic circuit tester with single liquid filled pressure gauge, 0-5,000 psi, 0-354 bar. Includes two adapter unions for $\frac{3}{4}$ " male NPT fittings. Wt., 37 lbs.

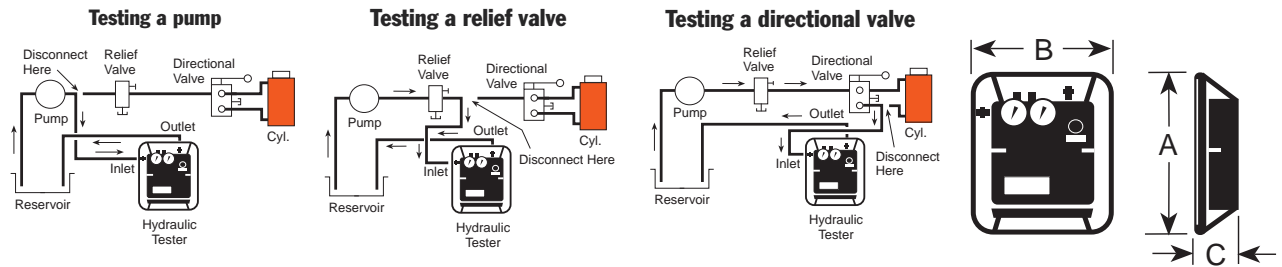

Order Number	Max Flow (gpm)	Scale	Flow Ranges		Max. Oper. Pressure		Temp. Scale Range		Port Sizes	Weight		A in. (mm)	B in. (mm)	C in. (mm)
			gpm	L/min.	psi	BAR	°F	°C		lbs.	kg.			
HT50A	50	—	0-50	0-200	5,000	345	20-240	-6 to 114	$1\frac{1}{16}$ -1.2UN Female "O" Ring with Union Adapt. $\frac{3}{4}$ " Female NPTF	30.3	16.8	12 $\frac{1}{4}$ (311)	6 $\frac{1}{4}$ (159)	10 (255)
HT75	75	High Low	15-75 3-15	50-300 10-60	5,000	345	100-250	40-120	$\frac{3}{4}$ " NPT Swivel	18.2	8.6	13 $\frac{3}{4}$ (349.25)	11 $\frac{7}{8}$ (301.62)	5 $\frac{3}{4}$ (146.05)
HT200	200	High Low	25-200 5-40	100-750 20-150	5,000	345	100-250	40-120	1 $\frac{1}{2}$ "* SAE Split Flange	28.2	13.6	15 $\frac{7}{8}$ (403.47)	13 $\frac{3}{4}$ (336.55)	6 $\frac{3}{4}$ (171.45)

For a complete listing of accessories for the HT series of hydraulic system testers, see pages 185-186. *Not included, must be ordered separately, see page 186.

TESTER

Hydraulic Service

Accessories



307281

DUAL GAUGE CONVERSION KIT FOR 50 GPM TESTER.

Provides more precise low pressure readings. Remove pressure gauge block and gauge from tester and replace it with this block. Install high pressure gauge from tester (0-5,000 psi) onto this new block.

No. 307281 – Dual gauge conversion kit. Consists of gauge mounting block, pulsation dampener, thermal overload protector, low pressure gauge and gauge protector. Wt. 1 lb.

307281 Low pressure gauge calibrated 0-600 psi 0-42 bar.



37045

No. 37045 – Auxiliary power cord. For use with any 12 or 24 volt battery to remotely power tester. Wt. 0.1 lb.
CAUTION: For use on negative ground systems only.

Auxiliary power cords for use with 75 and 200 gpm testers

No. 204990 – Auxiliary power converter. Permits use of 120/230 volt outlet to power tester. Wt. 1 lb.



204990

**9785
9786
8987
9788**



Hoses

No. 9785 – Hose, $\frac{3}{4}$ " I.D. x $\frac{3}{4}$ " NPTF male both ends. 10 ft. length. 2,250 psi working pressure. (2 req'd on 50 and 75 gpm testers) Wt., 0.7 lb.

The following hose assemblies are all 4-ply spiral wound wire, 10 ft. long. For use with 200 gpm testers.

No. 9786 – Hose, 1" I.D. x $\frac{1}{4}$ " NPT male both ends. Recommended max. flow 90 gpm, with a working pressure of 4,000 psi. Wt., 14 lbs.

No. 9787 – Hose, $\frac{1}{4}$ " I.D. x $\frac{1}{4}$ " NPT male both ends. Recommended max. flow 140 gpm, with a working pressure of 3,000 psi. Wt., 21 lbs.

No. 9788 – Hose, $\frac{1}{2}$ " I.D. x $\frac{1}{2}$ " NPT male both ends. Recommended max. flow 200 gpm, with a working pressure of 2,500 psi. Wt., 25 lbs.

HYDRAULIC TOOLS

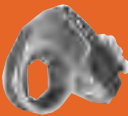

203264

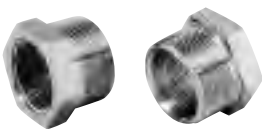

Hose reducer bushings

No. 203264 – Consists of two hose reducer bushings, $\frac{1}{4}$ " NPT female x $\frac{1}{2}$ " NPT male end. Needed to adapt No. 9786 1" I.D. hose and No. 9787 $\frac{1}{4}$ " I.D. hose to tester. Wt., 2.2 lbs.

HYDRAULIC TESTER

Service Accessories

Fittings/Adapters For the 200
GPM Hydraulic Tester

ATTACH TO THE HT200 HYDRAULIC TESTER BY THE USE OF FLANGED-HEAD ADAPTERS AND SPLIT FLANGES, OR BY A SET OF FEMALE SOTRAIGHT ADAPTERS.

FLANGED HEAD ADAPTER UNIONS AND SPLIT FLANGE KIT

















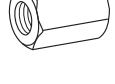



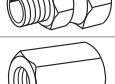

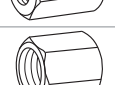

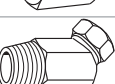
- No. 203154** – Straight flange adapter. 1½" flanged-head to 1½" NPSM female swivel. Wt., 2.2 lbs.
- No. 203155** – 45° flange adapter. 1½" flanged-head by 1½" NPSM female swivel. Wt., 3.2 lbs.
- No. 203156** – 90° flange adapter. 1½" flanged-head by 1½" NPSM female swivel. Wt., 4.2 lbs.
- No. 203017** – Split flange kit. Consists of four flange halves and attaching bolts to permit use of 1½" I.D. flange adapters listed at left. Wt., 2.9 lbs.

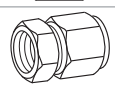
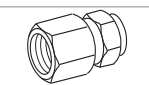

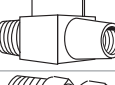
FEMALE STRAIGHT FLANGE ADAPTER

- No. 203003** – Consists of two female straight flange adapters with attaching bolts. When attached to inlet/outlet ports, allows connection of 1½" NPT male hose ends to tester. Wt., 8.5 lbs.

HYDRAULIC FITTINGS FOR USE WITH ALL TESTERS.

	No. 16954 – 90° swivel adapter, ¾" NPTF male x ¾" NPSM female. Wt., 0.8 lb.		No. 26073 – Swivel adapter, ¾" NPTF female x ½" NPSM female. Wt., 0.3 lb.
	No. 22041 – Coupler, ¾" NPTF male x ¾"-16 female ORB. Wt., 0.5 lb.		No. 26074 – 45° swivel adapter, ¾" NPSM female x ¾" NPTF male. Wt., 0.6 lb.
	No. 22042 – Coupler, ¾" –16 female ORB x 1½"-12 female 37° JIC. Wt., 0.4 lb.		No. 26075 – Swivel adapter, ¾" NPSM female x ¾" NPTF female. Wt., 0.4 lb.
	No. 22043 – Coupler, ¾" –16 female ORB x 9/16"-18 female 37° JIC. Wt., 0.4 lb.		No. 26076 – Swivel adapter, ¾" NPTF male x ¾" NPSM female. Wt., 0.4 lb.
	No. 22044 – Coupler, ¾" –16 female ORB x ½"-20 female 37° JIC. Wt., 0.4 lb.		No. 26077 – Cap, ¾" NPTF. Wt., 0.6 lb.
	No. 27737 – Swivel adapter, ¾" –16 male x ¾" NPSM female. For use with No. 9785 hose, which has ¾" NPTF male thread. Wt., 0.3 lb.		No. 26078 – Plug, ¾" NPTF. Wt., 0.3 lb.
	No. 27287 – Coupler, ¾" –16 UNF female ORB x 7/8"-14 UNF female 37° JIC. Wt., 0.4 lb.		No. 26079 – Adapter, ¾" NPTF female x 1½"-12 male ORB. Wt., 0.4 lb.
	No. 13449 – Cap, 1½"-12 UNF female, ¾" O.D. tube, 37° flare. Wt., 0.2 lb.		No. 208402 – 45° union adapter, 7/8"-14 UNF male 37° JIC x ¾" NPTF female. 3,000 psi working pressure. Wt., 0.6 lb.
	No. 26068 – 45° swivel adapter, 1" NPTF male x ¾" NPSM female. Wt., 0.8 lb.		No. 208401 – 45° union adapter, 7/8"-14 UNF male 37° JIC x ¾" NPTF female. Wt., 0.7 lb.
	No. 26069 – Swivel adapter, 1" NPTF female x ¾" NPSM female. Wt., 0.5 lb.		No. 206753 – Coupler, 1½"-12 UNF female 37° JIC x ¾" NPTF female. Wt., 1.1 lbs.
	No. 26070 – Adapter, 1" NPTF male x ¾" NPTF female. Wt., 0.3 lb.		No. 26666 – Connector, 1½"-12 UNF male 37° JIC x ¾" NPTF male. Wt., 0.4 lb.
	No. 26071 – Service tee, ¾" NPTF female (2) x ¾" NPTF male. Wt., 0.9 lb.		No. 28984 – Straight adapter, ¾" NPTF female x 1½"-12 UN male 37° JIC. Wt., 0.6 lb.
	No. 26072 – Swivel adapter, ¾" NPSM female x ½" NPTF male. Wt., 0.4 lb.		No. 28985 – Straight adapter union, 1½"-12 UN female 37° JIC x ¾" NPTF female. Wt., 1.3 lbs.

NOTE: The recommended maximum working pressure on the above fittings is 5,000 psi except the 208402.



RETAINING RING PLIERS

Internal and External



7313



714

HORSESHOE LOCK RING PLIER

- For removing horseshoe lock rings used on hydraulic brakes, differentials, etc. Plier is 8" long; max. spread: $\frac{15}{16}$ "

No. 714 – Horseshoe lock ring plier. Wt., 0.4 lb.

No. 7313 – External snap ring plier easily removes snap rings used to retain bearings on shafts. Max. spread: $\frac{17}{16}$ ".

RETAINING RING PLIER KITS

- Choose from four sets; internal ring, external ring and convertible pliers for either internal or external rings.

No. 7053K – Replaceable tip pliers kit. This versatile kit contains (1) internal and (1) external pliers with (8) tip sets. Two sets each: .038 dia. 90° bend, .047" dia. straight, .047" dia. 90° bend, .070" dia. straight. Recommended for $\frac{1}{4}$ "–2" rings. Packaged in plastic storage case. Wt., 0.8 lb.

No. 15702 – Replaceable tip kit (only) for No. 7053K.

No. 7123K – Convertible pliers kit. Contains **No. 1120** (.038" dia./straight tip) and **No. 1340** (.070" dia./straight tip). Each pliers "converts" to handle both internal and external rings. Packaged in a reusable plastic storage case. Wt., 0.8 lb.

No. 7125K – Convertible pliers kit. Contains **No. 1125** (.038" dia./45° bent tip) and **No. 1345** (.070" dia./45° bent tip). Each pliers "converts" to handle both internal and external rings. Packaged in a reusable plastic storage case. Wt., 0.8 lb.

No. 7406K – Professional pliers kit. Contains (6) retaining convertible pliers to handle both internal and external rings from $\frac{1}{4}$ "–2". Includes straight and 90° off-set pliers with .038", .047", and .070" tip diameters. Includes Nos. 1120, 1131,

1320, 1329, 1340 and 1349. Packaged in an impact resistant storage case. Wt., 2 lbs.

REPLACEMENT TIPS FOR 7300 AND 7301 PLIERS

No. 209201 – Replacement tips (pr.) for the 7300 and 7301 pliers. Wt., 0.1 lb.

Fed. Spec.: GGG-P-480



7053K
internal &
external
plier, 4 sizes
of tips.

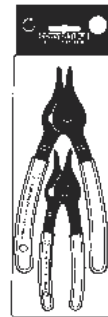

7123K



7406K

RETAINING RING PLIERS SELECTION GUIDE

Plier No	Tip Bend	Tip Size Dia. (in.)	For Int'l Rings* Bore Dia. (in.)	For External Rings* Shaft Dia. (in.)
0100	Str.	.038	.375 – 1.023	—
0200	Str.	.038	—	.250 – .875
0300	Str.	.070	1.062 – 1.750	—
0400	Str.	.070	—	.938 – 1.438
0500	Str.	.090	1.812 – 3.500	—
0600	Str.	.115	—	1.500 – 3.500
7300	Str.	.120	3.062 – 6.000	—
7301	Str.	.120	—	3.543 – 6.500
Convertible Pliers				
1120	Str.	.038	.375 – .562	.250 – .672
1125	45°	.038	.375 – .562	.250 – .672
1131	90°	.038	.375 – .562	.250 – .672
1320	Str.	.047	.625 – 1.023	.687 – .875
1329	90°	.047	.625 – 1.023	.687 – .875
1340	Str.	.070	1.062 – 1.750	.938 – 1.438
1345	45°	.070	1.062 – 1.750	.938 – 1.438
1349	90°	.070	1.062 – 1.750	.938 – 1.438

*Capacities are shown for basic style rings.

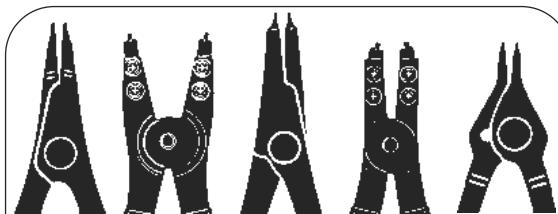

External Internal Convertible

No. 0200 No. 7301 No. 0100 No. 7300 No. 1120
 No. 0400 No. 0300 No. 1320
 No. 0600 No. 0500 No. 1340

No. 1125*
 No. 1345*
 No. 1131**
 No. 1329**
 No. 1349**

Fed. Spec.: GGG-P-480-E

* 45° Angled Tips ** 90° Angled Tips



CAUTION: Always wear safety goggles when using pliers

SERVICE TOOLS

Accessories

PHOTO TACHOMETER

- Infrared light source, micro-processor controlled crystal display.
- Strong magnetic base is included.

Machine speed: It is critical for proper machining operations. Speeds too fast or too slow can shorten tool life and cause expensive, unnecessary machine downtime. This digital photo tach can take readings from revolving shafts on drill presses, grinders, lathes and other machines. It can also be used to check engine operation on in-plant vehicles like forklifts. The 3344 is accurate to within ± 1 rpm. The $\frac{3}{32}$ " high liquid crystal display is easily visible even in high ambient light areas.

HTS50 HEAVY-DUTY PIPE SEALANT WITH TEFLON®

- Seals new or damaged threads; resists water, chemicals and oils.
- Replaces conventional tape methods; forms a clog-free seal. Effective at 10,000 psi.

When "plumbing" a hydraulic system, there's now a better answer than tapes which can tear or shred, possibly plugging filters, valves or gauges. This compound combines the lubri-

No. 3344A – Digital Photo Tachometer. With memory, photo probe assembly, magnetic base, 108" of reflective tape and plastic case. Wt., 4.5 lbs.

No. 39811 – Replacement magnetic base assembly. Wt. 0.3 lb.

No. 45329 – Replacement photo probe assembly. Wt., 0.4 lb.

No. 204666 – Replacement retro-reflective indicator tape, 108" long x $\frac{1}{2}$ " wide. Wt., 0.1 lb.

SPECIFICATIONS

Readout: Liquid crystal display: 4 ($\frac{13}{32}$ " high) digits, low battery indicator, memory mode indicator, high and low RPM memory mode indicator.



3344A

Range: 200 to 9999 rpm. Accuracy: $\pm .25\%$, ± 1 rpm. Update time: $\frac{1}{4}$ second.

Power switch: Membrane switch (automatic shut-off after one minute of no signal input).

Power source: 9 volt alkaline battery. Light source: Infrared with 15-foot plug-in cable.

Light holder assembly: 30 lb. rated magnet; 2" dia. x $\frac{1}{4}$ " high (4" high overall with post).

Size: $3\frac{7}{8}$ " w, 6" h x $1\frac{1}{2}$ " d.

C case: $13\frac{1}{2}$ " w, 10" h x 4" d.

cating qualities of Teflon® with a fast curing anaerobic sealant. Seals all metal fittings, plugs and threaded joints quickly and easily. Cures to form a permanent seal which is inert to hydrocarbons, most acids, chemicals, solvents and steam. Allows adjustment up to 16 hours after assembly; cannot loosen under vibration. Prevents galling of mating parts upon disassembly. Withstands temperatures from -65° F to +375° F.

No. HTS50 – Sealant, 50 ml. tube. Wt., 0.4 lb. (Teflon® is a registered trademark of duPont Co.)

HTS50



"O" RING SEAL PICKS

Even the seemingly simple job of removing and installing "O" ring seals can be difficult without the aid of the proper tool. The 7312 all metal "O" ring seal pick does the

job with ease. Two special picks in set No. 7103 get right to the trouble areas.

No. 7312 – "O" ring seal pick. Wt., 0.1 lb.

No. 7103 – Set of two "O" ring seal picks. Wt., 0.1 lb.

7312



7103



UNIVERSAL OUTSIDE THREAD CHASER

Restore damaged threads on shafts, housings, cages, etc., for re-assembly of matching parts. Eliminates need for thread-cutting equipment. Will not harm threads. V-pads and dies can be replaced. Cap. $1\frac{1}{4}$ " to 5" O.D.

No. 7402 – Thread chaser, complete (with 6 dies: threads per inch – 4, 5, 6, 7, $7\frac{1}{2}$, 8, 9, 10, 11, $11\frac{1}{2}$, 12, 14, 16, 18, 20 and 24). Wt., 4.5 lbs.

No. 202817 – Metric die set (3 dies: mm per thread: 1, 1.25, 1.5, 1.75, 2, 2.5, 3, 3.5, and 4). Wt., 0.2 lb.

7402



MAGNETIC PICK-UP TOOL

Has permanent magnetic head for retrieving parts from otherwise inaccessible places.

No. 7395 – Pick-up tool with pocket clip. 6" lg. Wt., 0.1 lb.

7395



MECHANICAL TOOLS

WRENCHES, PRY BARS

Spanners & Jimmy Bars

RATCHETING CHAIN WRENCHES

Special head design allows you to turn wrench in either direction. Ratcheting action makes it possible to re-grip without removal. For parts of most any size and shape.

No. 7400 – Chain wrench, cap. 1/2" to 4 3/4" O.D. (Capacity= 333 ft. lbs.) Wt., 2 lbs.

No. 7401 – Chain wrench, cap. 3" to 6 3/4" O.D. (Capacity= 666 ft. lbs.) Wt., 5 lbs.

No. 209199 – Replacement chain with pin for No. 7400 chain wrench (16" long).

No. 209200 – Replacement chain with pin for No. 7401 chain wrench (24" long).

ADJUSTABLE HOOK

SPANNER WRENCH

Needed wherever turret adjusting nuts or packing gland nuts are used. Cap.: 1 1/2" to 4". Handle overall length: 19".

No. 885 – Adjustable hook spanner wrench. Wt., 3 lbs.

ADJUSTABLE HOOK SPANNER WRENCHES

Replace many fixed-size wrenches... cover range of capacities needed to service industrial tractors and other equipment. Drop-forged jaws adjust to eleven positions for a capacity of 4 3/4" to 12 3/4" O.D. Handle overall length: 24"; diameter: 1".

No. 7307 – Spanner wrench with one 3/8" thick jaw. Wt., 7.3 lbs.

No. 7308 – Spanner wrench with two interchangeable jaws: one 3/8" thick, one 3/4" thick. Wt., 11 lbs.

HEAVY-DUTY ADJUSTABLE SPANNER

Extra heavy construction. Has one 3/4" thick, eleven-position hook-jaw for a capacity of 4 3/4" to 12 3/4" O.D. Drop-forged. Handle length: 25 3/4"; handle dia.: 1 5/16".

No. 7309 – Heavy duty adjustable hook spanner wrench. Wt., 13.3 lbs.

ADJUSTABLE GLAND NUT WRENCH

Designed to handle 2" to 6" dia. hydraulic cylinder gland nuts on many construction vehicles. Fits 1/4" and 5/16" dia. pin holes; features a 3/4" sq. drive.

No. 1266 – Adjustable gland nut wrench. Wt., 3 lbs.

No. 204928 – Replacement pin for No. 1266

PRY BARS

Our rolling head pry bars are an extremely popular and useful tool. Head may be used for almost any prying job since a great deal of leverage can be obtained. Long tapered body may be used as a lining-up drift.

No. 7162 – Pry bar; 3/8" round, 6" long. Wt., .3 lb.

No. 7163 – Pry bar; 7/16" round, 12" long. Wt., .6 lb.

No. 7164 – Pry bar; 9/16" round, 16" long. Wt., 1.1 lbs.

No. 7165 – Pry bar; 3/4" round, 18" long. Wt., 2.2 lbs.

JIMMY BARS

Ideal for general lifting or prying. Heat treated chrome alloy steel to resist bending or breaking.

No. 7166 – Jimmy bar; 5/8" round, 18" long. Wt., 1.4 lbs.

No. 7167 – Jimmy bar; 3/4" round, 24" long. Wt., 2.5 lbs.

No. 7168 – Jimmy bar; 7/8" round, 30" long. Wt., 4.3 lbs.

"MAJOR PERSUADER" JIMMY BARS

Two big jimmy bars for big jobs. Forged from chrome alloy steel.

No. 7420 – Jimmy bar; 7/8" round, 46" long. Wt., 7.5 lbs.

No. 7421 – Jimmy bar; 1" round, 54" long. Wt., 11.3 lbs.



PULLERS



Page
PULLER BASICS...192-195



Page
...209
**PROTECTIVE
BLANKETS**



Page
MECHANICAL JAW PULLERS...196



Page
...210
**2/3 JAW PULLERS
GRIP-O-MATIC**



Page
MECHANICAL PUSH PULLERS...198



Page
...211
**PULLER
ACCESSORIES
GRIP-O-MATIC**



Page
PULLING ATTACHMENTS...200



Page
...212-213
PUSH PULLER



Page
PULLING SLIDE HAMMER...202

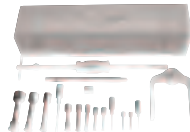

Page
...216
**HYDRAULIC
PULLER SETS**



Page
PULLER SETS...204



Page
...221
BEARING PUSHER



Page
ADAPTERS...206



Page
...222
UNIVERSAL PULLER



Page
MANUAL PULLER SETS...208



Page
...224
**ROLLER BEARING
PULLER/ INSTALLER**



Page
...226
**BEARING, BUSHING,
SEAL DRIVERS**



PULLER SELECTION BASICS

3 Basic Puller Scenarios

CONSIDERATIONS:

Determine the type of puller or puller combination. Which puller type is best suited for gripping the part?

Is a combination of puller types required?

Determine the reach needed for your particular pulling problem. The puller you select must have a reach equal or greater than the corresponding sizes of the part to be pulled.

Determine the spread need. The spread

is determined by the width of the part being pulled. The puller's spread should be greater than the width of the part to be pulled.

Estimate the force needed to solve your pulling problem. A puller with the proper reach and spread will usually have enough capacity to remove the corresponding part. When in doubt, always use a puller with a larger capacity than what may be needed. Rusted parts or parts with a large area of resistance may need more pulling force.

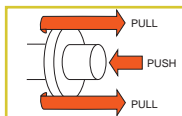

1

PULLING A GEAR, BEARING, WHEEL, PULLEY, ETC., FROM A SHAFT

In order to perform a proper pull, be certain that you firmly grip the gear, bearing, wheel, pulley, etc., and apply force to the shaft. Use a 3-jaw puller, instead of a 2-jaw, whenever possible for better gripping power and a more uniform displacement of pulling force.

RECOMMENDED TOOLS:



Jaw-type pullers: Either manual or hydraulic. For extra force and convenience, use a hydraulic puller. Both are available in 2 or 3 jaw configurations and are used to grip the outer circumference of a part or can be used with a pulling attachment, such as a bearing/pulley attachment. **(pages 196-197, 210-213, 222-223)**



Push-Pullers can thread directly into a threaded part for easy and secure removal. Push-Pullers can be used in conjunction with bearing/pulley attachments which grip the part from behind. A wide assortment of male and female threaded adapters are available as well as metric adapters. **(pages 198-199, 214-215)**



Slide hammers are best suited for light-duty tasks. Slide hammers can be used for multiple- with pulling problems when combined pulling attachments. **(pages 202-203)**



Bearing/pulley attachments provide a "knife-like" edge to get behind parts for added versatility and secure removal of parts. Great for parts that don't offer adequate grip with jaw-type pullers. **(page 201)**



Adapters Whether you need an adapter compatible with any number of threaded hole sizes, protection of part to be pulled or for assisting the installation of a component; Power Team offers a variety of adapters to assist in the removal or installation of parts. **(pages 206-207)**



2

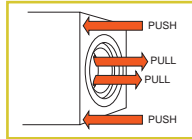

PULLING INTERNAL BEARING RACES, RETAINER, SEALS, ETC.

By extending the narrow jaws of an internal pulling attachment through the center of the part to be pulled, a straight pull is insured, and damage to the housing is avoided. While parts within a "blind hole" in a housing do present a problem, Power Team has the internal pulling attachment or a combination of an internal pulling attachment and puller to handle the situation.

RECOMMENDED TOOLS:



Internal pulling attachments have narrow jaws which extend through the center of the part to be pulled. They provide a straight pull and avoid damaging housings. Internal attachments feature adjustable jaws to fit various diameter parts. (page 200)

Slide hammer with internal attachment is ideal for removing parts from blind holes, especially where there is no housing to brace puller legs against. (pages 202-203)



Push-puller with internal attachment. Push-puller is available in both manual and hydraulic versions. (pages 198-199)



3

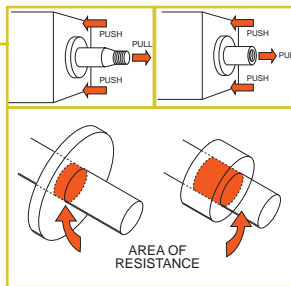

PULLING A PRESS-FITTED SHAFT FROM A HOUSING

Note: Manual pullers require that the shaft being pulled is no more than twice the diameter of the puller's forcing screw. To determine the recommended tonnage for hydraulic pullers, multiply the diameter of the shaft to be pulled by ten. Example: For a 1" shaft, we recommend 10 tons of pulling force.

A shaft with a threaded end can be removed without damage by using one of our slide hammer, manual Push-puller or hydraulic Push-pullers, in conjunction with the proper threaded adapter. Removal is easy! If the shaft to be removed has external threads, simply choose one of our female threaded adapters of proper size/thread. If the shaft has internal threads, simply choose the correct size male threaded adapter.

RECOMMENDED TOOLS:



Slide hammer puller matched with a set of threaded adapters is a perfect tool for light duty pulling needs. (pages 202-203, 206-207)

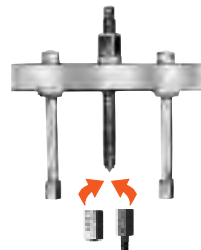

Push-pullers matched with a set of threaded adapters make for an extra versatile pulling tool. (pages 198-199, 206-207, 214-215)



PULLER SELECTION BASICS

Choosing the Right Puller



Puller with a bearing pulling attachment was used to take a bearing off a utilities well pump motor.

WHY OUR ROLLED PULLER THREADS ARE SUPERIOR:

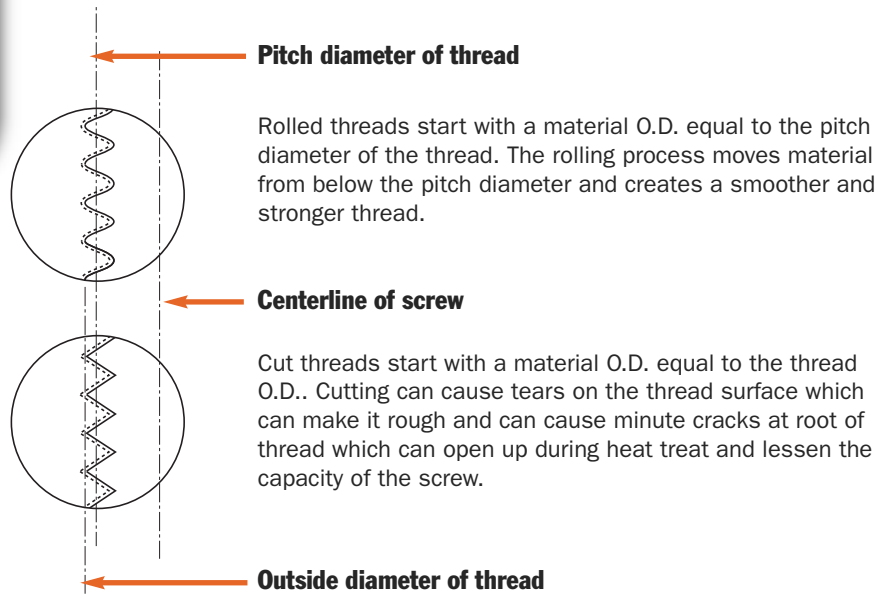

Features

Benefits



- Grip-O-Matic® feature on jaw type pullers
- 2-way, 3-way and 2/3-way combination pullers
- 1 to 37 ton mechanical pullers
- 5 to 50 ton hydraulic pullers
- 2¹/₈" (54 mm) to 27⁵/₈" (702 mm) reach
- 3¹/₄" (83 mm) to 44" (1,118 mm) of spread
- Forged alloy steel jaws
- Machined puller jaw toes
- Alloy steel heads (forged or flame cut)
- Rolled "V" threads
- Special coating on threads
- Heat treated alloy steel cross bolts
- Standard hydraulic cylinders on Grip-O-Matic® series
- Adjusting nut on Super Grip-O-Matic® series

- The harder the pulling force, the tighter the jaws grip
- A wide variety of pullers; select a specific puller for a specific application or select one or more pullers for general applications
- Strongest possible part; the grain of the material follows the contour of the part.
- Larger and stronger pulling toe than most competitors
- Heat treated and designed for maximum strength
- Stronger and smoother than cut threads
- Resists corrosion, traps lubrication better than black oxide
- Designed for max. shear strength
- Cylinder can be removed from puller and used in other hydraulic applications
- Allows for controlled jaw spread adjustment

NOTE: The puller application photos shown in this catalog are shown without protective blankets for clarity of photos. Power Team strongly recommends you always make your pull with a protective device in place.



Operator safety comes first!

Tons of force are being exerted with your Pulling System. You must respect this force, and observe safety precautions at all times

⚠ CAUTION

It is impossible to predict the exact force required for every pulling job: setup requirements and the size, shape and condition of the parts being pulled vary a great deal. In addition, the Power Team Pulling System is so versatile, it is possible that components in a pulling setup may have different tonnage ratings.

The lowest “capacity” component, then, determines the capacity of the setup. For example: When an accessory with a 1 ton capacity is used with a 10 ton capacity puller, the setup can be used only at a force of one ton.

These tools should be used only by trained personnel familiar with them.

Always wear eye protection during a job since work parts, or the pulling tool itself, may break and parts may fly. It is recommended to cover the work with a Power Team Protective Blanket or use a shield while force is being applied. If you are at all unsure which tool or attachment to select, contact the Power Team factory.

A few easy tips to remember:

- 1. Wear safety glasses at all times!** You have only one pair of eyes, so protect them from possible flying parts.
- 2. Keep your pulling tools in shape!** Clean and lubricate the puller’s forcing screw frequently, from threads to tip, to assure long service life and proper operation.
- 3. Cover work with a protective blanket!** With high forces being exerted on the part being pulled, breakage may sometimes result. By covering the work with a protective blanket, the mechanic reduces the danger of flying parts.
- 4. Apply force gradually!** The component should give a little at a time. Do not try speed removal by using an impact wrench on the puller screw.
- 5. Use the right size puller!** If you have applied maximum force and the part has not moved, go to a larger capacity puller. Resist sledging.
- 6. Align puller legs and jaws!** Be sure the setup is rigid and that the puller is square with the work.
- 7. Mount puller so grip is tight!** Tighten the adjusting strap-bolts when using a jaw type puller. Always use a 3-jaw puller whenever possible. A 3-jaw puller gives a more secure grip, more even pulling power. Apply force gradually. — Never use an extension on a wrench. — Never use an impact wrench. — Never strike the end of the forcing screw. Always cover work with a protective blanket.
- 8. Do not couple puller legs!** The tonnage capacity of a Push-Puller® is reduced when longer than standard legs are used, or when legs are in compression. The chance of breaking, bending or misaligning legs increases. Keep reach to a minimum. Use shortest legs possible to reach workpiece. Thread legs into workpiece, pulling attachment or adapters evenly. Uneven legs will cause greater pull or push on one side, creating a bending action which could cause damage to work piece or cause a leg to break. The sliding plates must always be on the opposite side of the cross block from the forcing screw nut or hydraulic cylinder. Always cover work with a protective blanket.

Bearing pulling attachments:

These attachments may not withstand the full tonnage of the pullers with which they are used. The shape and condition of the part being pulled affects the tonnage at which the puller blocks and/or studs may bend or break. Always select the largest attachment which will fit the part to be pulled.

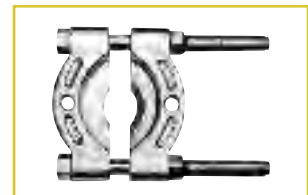
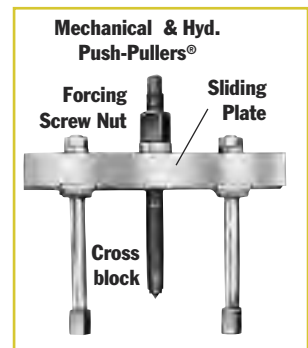

JAW PULLERS

Mechanical

2 & 3 Jaw Pullers

Choosing the right size puller:

Compare the “reach” and “spread” of the pulling job with that of the pullers listed. The puller selected must have dimensions greater than those of the job.

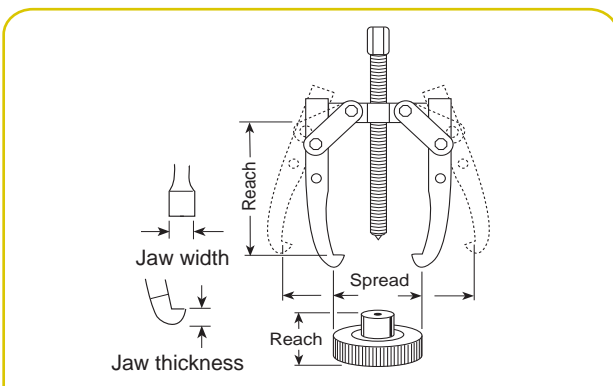
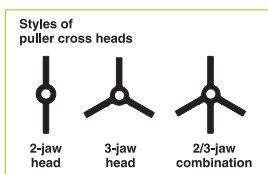









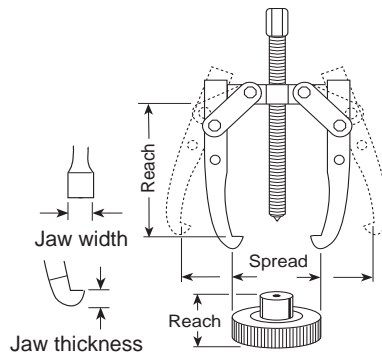



- Grip-O-Matic® feature on all pullers. The harder the pull, the tighter the grip for removing gears, bearings and countless other press fitted parts.
- 2-way, 3-way and 2/3 way combination pullers make it easy to select a specific puller for a specific application.
- Forged from high quality steel, heat treated and subjected to rigorous tests which exceed rated puller capacity.
- Meets Fed. Spec.: GGG-P-00781-D

Order No.	Max.		Screw Size (in.)	Jaw		Capacity, Style and Weight
	Reach (in.)	Spread (in.)		Thickness (in.)	Width (in.)	
1020	2 ¹ / ₈	3 ¹ / ₄	5 ¹⁶ / ₁₆ -24 x 3 ⁷ / ₈	9 ⁹ / ₆₄	1 ¹ / ₄	1-Ton, 2-Jaw; 5 oz.
1021	2 ¹ / ₈	3 ¹ / ₄				
1022	3 ³ / ₈	4	3 ⁸ / ₈ -24 x 4 ⁷ / ₈	Upper 3 ¹⁵ / ₁₆ Lower 1 ¹ / ₈	Upper 1 ¹ / ₄ Lower 1 ¹ / ₂	2-ton, 2-Jaw; 14 oz. (Reversible Jaws)
1023	3 ³ / ₈	4 ³ / ₄				
1024	3 ¹ / ₄	6	9 ¹⁵ / ₁₆ -20 x 6 ¹⁵ / ₁₆	Upper 1 ¹⁵ / ₁₆ Lower 1 ¹ / ₄	Upper 3 ³ / ₈ Lower 3 ³ / ₄	5-Ton, 2-Jaw; 1 lb., 12 oz. (Reversible Jaws)
1026	3 ¹ / ₄	7				



- Alloy steel heads are forged for maximum strength.
- Forcing screw threads are rolled, not cut. This process creates a smoother and stronger thread.
- Heat treated alloy steel cross bolts for maximum shear strength.
- Machined puller jaw toes produce larger and stronger pulling toes.



Order No.	Max.		Screw Size (in.)	Jaw		Capacity, Style and Weight	
	Reach (in.)	Spread (in.)		Thickness (in.)	Width (in.)		
1025  1027 	1025	5½	6	9/16-20 x 6 15/16	Upper 5/16 Lower 1/4	Upper 3/8 Lower 3/4	5-Ton, Long 2-Jaw; 2 lbs. (Reversible Jaws)
	1027	5½	7	9/16-20 x 6 15/16	Upper 5/16 Lower 1/4	Upper 3/8 Lower 3/4	5-Ton, Long 2/3-Jaw; 3 lbs., 10 oz. (Rev. Jaws)
1035  1037 	1035	5	9	11/16-18 x 9	Upper 5/16 Lower 11/32	Upper 1 Lower 1	7-Ton, 2-Jaw; 4 lbs., 8 oz. (Reversible Jaws)
	1037	5	10½	11/16-18 x 9	Upper 5/16 Lower 11/32	Upper 1 Lower 1	7-Ton, 2/3-Jaw; 6 lbs., 2 oz. (Rev. Jaws)
1036  1038 	1036	8¾	9½	11/16-18 x 9	11/32	1	7-Ton, Long 2-Jaw; 5 lbs., 6 oz.
	1038	8¾	11	11/16-18 x 9	11/32	1	7-Ton, Long 2/3-Jaw; 8 lbs., 2 oz.
1039/1040  1041/1042 	1039	11	12	13/16-16 x 12	9/16	1	13-Ton, 2-Jaw; 10 lbs., 13 oz.
	1040	15¼	15½	13/16-16 x 12	9/16	1	13-Ton, Long 2-Jaw; 13 lbs.
	1041	11	12	13/16-16 x 12	9/16	1	13-Ton, 2/3-Jaw; 16 lbs., 4 oz.
	1042	15¼	17	13/16-16 x 12	9/16	1	13-Ton, Long 2/3-Jaw; 18 lbs., 12 oz.
1043/1044  1045/1046 	1043	14½	14	1"6 x 12	9/16	1	17½-Ton, Long 2/3-Jaw; 18 lbs., 12 oz.
	1044	18¾	16	1-14 x 13½" lg.	13/16	1 9/32	17½-Ton, Long 2-Jaw; 23 lbs.
	1045	14½	14	1-14 x 13½	13/16	1 9/32	17½-Ton, 3-Jaw; 33 lbs.
	1046	18¾	16	1-14 x 13½	13/16	1 9/32	17½-Ton, Long 3-Jaw; 37 lbs.
1048  1050 	1048	22¼	20	1¼-12 x 16 5/8	1 1/16	1½	25-Ton, Long 2-Jaw; 42 lbs., 12 oz.
	1050	22¼	20	1¼-12 x 16 5/8	1 1/16	1½	25-Ton, Long 3-Jaw; 60 lbs.



For puller piece part identification, order Power Team parts catalog PC97

PUSH PULLERS

Mechanical

10, 17¹/₂, & 30 Ton Cap.

Selection and capacity rating – Each Push-Puller's specified tonnage "capacity" is determined using its standard legs in tension. Using longer legs, or a setup in which the legs are in compression, will reduce the "capacity". Always select the largest "capacity" puller and the shortest legs that will fit the job.

- Can apply a pushing or pulling force, depending on how the puller is set up.
- Optional leg kits adapt your Push-Puller® to extra long or extra short reach.
- A wide variety of threaded adapters, bearing pulling attachments and internal pulling attachments can be used in combination with our Push-Pullers.®
- Meets Fed. Spec.: GGG-P-00781-D

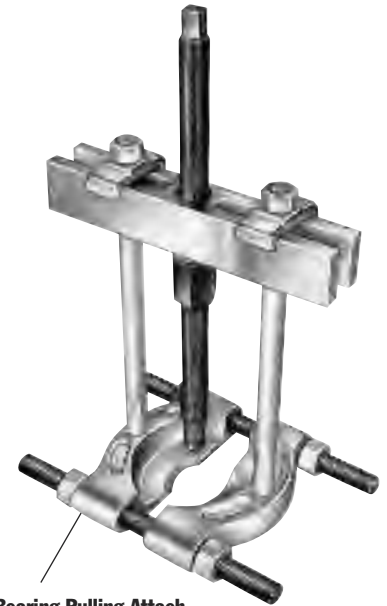

Bearing Pulling Attachment

ASSEMBLING THE TOOL TO APPLY PUSHING OR PULLING FORCE:

1. Determine if you want the tool's forcing screw to push or pull.
2. To exert pushing force, the forcing nut is installed beneath the cross block, as shown on left.
3. To cause the forcing screw to pull, the forcing nut is placed on top of the cross block.
4. The sliding plates must always be placed on the opposite side of the cross block from the forcing nut.

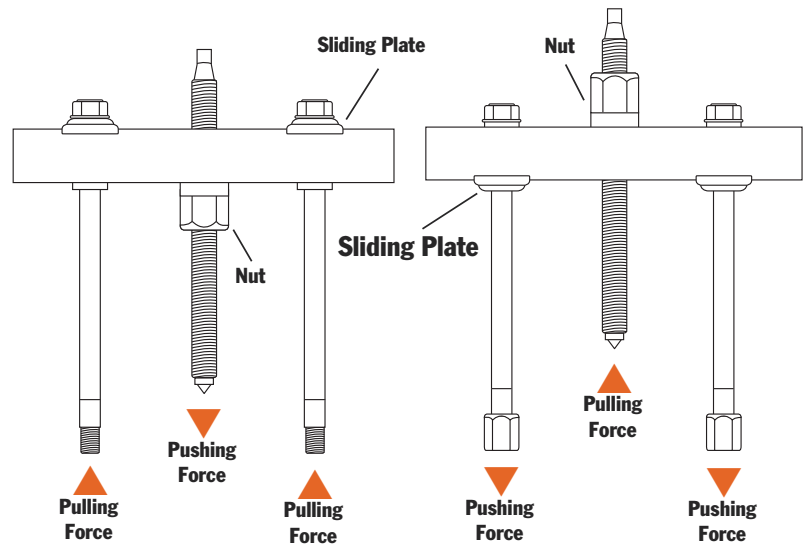

Available Adapters (page 206-207)



Male/Female



Step Plate



Shaft Protector



Female



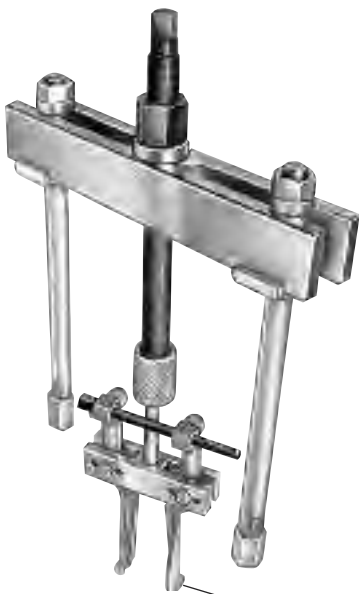

Internal Pulling Attachment

No. 927 – 10-Ton Capacity can be used with No. 1123 bearing pulling attachment or No. 679 pulley pulling attachment. May also be used with Nos. 1150, 1151, 1152, or 1153 internal pulling attachments.

No. 938 – 17½-Ton Capacity can be used with Nos. 1124 and 1130 bearing pulling attachments or Nos. 679 and 680 pulley pulling attachments. May also be used with Nos. 1150, 1151, 1153, 1165, or 1166 internal pulling attachments.

No. 939 – 30-Ton Capacity can be used with Nos. 1126 and 1127 bearing pulling attachments or No. 680 pulley pulling attachment (two 8012 adapters are required to connect 680 to puller). Can be used with No. 1165 internal pulling attachment.

927		Max.				
	Reach	Spread	Screw	Size	Notes / Weight	
	8¼"	2⅝" – 7¼"	¾"–16 x 12"		½" of forcing screw tip end is threaded ⅝"-18. No. 1100 legs and No. 24827 leg ends included. Wt., 7 lbs.	
927	Order No. Leg Length & Wt.		Order No. Leg Length & Wt.			
	1103	4¾" 1 lb.		1102	11¾" 2 lbs., 4 oz.	
	1100	6¾" 1 lb., 8 oz.		1101	15¾" 3 lbs., 4 oz.	
	Extra Legs (pair) for No. 927 Push-Puller (Reach equals leg length plus 1½" with leg end caps.)					

938		Max.				
	Reach	Spread	Screw	Size	Notes / Weight	
	11⅝"	3⅞"–11¾"	1"–14 x 13¼"		Leg ends threaded ⅝"-18. No. Spread 1106 legs and No. 24827 leg ends included. Wt., 20 lbs., 12 oz.	
938	Order No. Leg Length & Wt.		Order No. Leg Length & Wt.			
	1107	4.5" 2 lbs., 8 oz.		1105	22½" 9 lbs.	
	1106	9½" 4 lbs., 8 oz.		1108	30" 11½ lbs.	
	1104	16½" 6 lbs., 8 oz.				
	Extra Legs (pair) for No. 938 Push-Puller (Reach equals leg length plus 2" with leg end caps.)					

939		Max.				
	Reach	Spread	Screw	Size	Notes / Weight	
	10½"	7"–16¼"	1½"–12 x 17¼"		Leg ends threaded 1"–14. No. 1109 legs and No. 28390 leg ends included. Wt., 44 lbs.	
939	Order No. Leg Length & Wt.		Order No. Leg Length & Wt.			
	1109	8" 8 lbs.		1111	28" 22 lbs.	
	1110	18" 15 lbs.				
	Extra Legs (pair) for No. 939 Push-Puller (Reach equals leg length plus 2⅝" with leg end caps.)					



PULLER ATTACHMENTS

1 1/2" - 9" Jaw Spreads

RECOMMENDED FOR THE REMOVAL OF BEARINGS, BEARING CUPS, BUSHINGS AND OIL SEALS.

- Handles internal pulling jobs, such as, bearing/bearing cup removal, bushing removal, oil seals, etc.
- Remove hard to get at parts easily and without damage!
- Use with corresponding Power Team Slide Hammer or Push-Puller.®
- Adjustable jaws fit various diameters
- Meets Fed. Spec.: GGG-P-00781-D

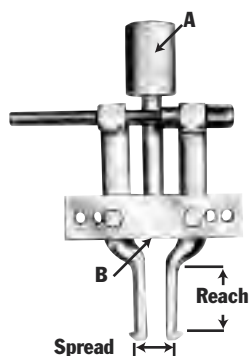

CAUTION – These attachments may not withstand the full tonnage of the pullers they are used with. The shape and condition of the part being pulled affects the tonnage at which the jaws may slip off. Always select the largest attachment which will fit behind the part being pulled.

Order No.	Jaw		A (in. - thd.)	B (in. - thd.)	Wt. (lbs.)	Application
	Spread (in.)	Reach (in.)				
1153	1 1/2-5	2 1/8	1-14	5/8-18	4 lbs., 4 oz.	Use with Nos. 927 and 938 Push-Pullers,
1150	1 1/2-6	4	1-14	5/8-18	4 lbs., 4 oz.	
1151	1 1/2-7	5 1/4	1-14	5/8-18	4 lbs., 8 oz.	
1152	1 1/2-6	4	-	5/8-18	3 lbs., 8 oz.	Use with Nos. 927 and 938 Push-Pullers, 1155 and 1156 slide hammer pullers, or 24832 and 24833 puller screw.
1154	1 1/2-6	4	1-8	5/8-18	4 lbs., 8 oz.	Use with No. PPH17.
1165	3-9	5 7/8	1 1/2-12	1-14	13 lbs., 8 oz.	Use with No. 939 Push-Puller.
1166	3-9	5 7/8	1 1/4-7	1-14	13 lbs., 8 oz.	Use with No. PPH30.
Puller Screws						
24832	13 3/4 long		5/8-18	1 lb.	Use with Nos. 1150, 1151, 1152, and 1153. Acts as a regular forcing screw when threaded directly into block of pulling attachment.	
24833	5 1/2 long		5/8-18	6 oz.	Use with Nos. 1150, 1152, and 1153. Acts as a regular forcing screw when threaded directly into block of pulling attachment.	



PULLER ATTACHMENTS

Bearing & Pulley



USED WHERE SPACE DOES NOT PERMIT HOOKING PULLER JAWS DIRECTLY ON PART TO BE PULLED.

- “Knife-like” edges fit behind bearings and other hard-to-grip parts for easy removal, even where clearance is limited.
- Usable with both Grip-O-Matic® jaw type pullers and Push-Pullers®.
- All puller blocks are made from forged alloy steel
- Meets Fed. Spec.: GGG-P-00781-D

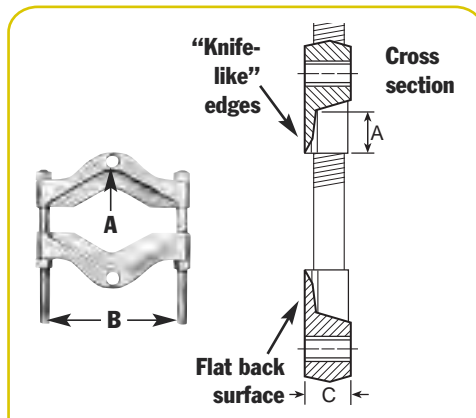

Attachment clamps down into V-groove to distribute load.
Use with Grip-O-Matic® pullers or Push-Pullers.

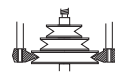

X = Thread of tapped hole in adapter.
Y = Distance between adjusting screws.

Order No.	Max. Spread (in.)	Min. Spread (in.)	A (in.)	B (in.)	Wt.	Application - (Use with Puller Nos.)
1121	1 ⁵ / ₁₆ "	1/4"	5/16"-18	1 ¹¹ / ₁₆ "	12 oz.	1020, 1022, and 1023.
1122	2"	1/8"	3/8"-16	2 ⁷ / ₁₆ "	1 lb., 4 oz.	1024, 1025, 1026, 1027, 7392 and 7393.
1123	4 ⁵ / ₈ "	1/2"	5/8"-18	4 ³ / ₈ "	5 lbs.	1035, 1036, 1037, 1038, and 927.
1124	5 ³ / ₄ "	1/2"	5/8"-18	6"	12 lbs.	1035, 1040, 1041, 1042, PH172, PPH17, and 938.
1126	8"	5/8"	1"-14	7 ¹ / ₂ "	19 lbs., 12 oz.	1047, 1043, and 939.
1127	13 ³ / ₈ "	3/4"	1"-14	10 ¹ / ₄ "	41 lbs., 12 oz.	1047, 1073, and 939.
1128	12 ⁷ / ₈ "	5"	1 ³ / ₄ -12	13"	100 lbs.	PH302*, PH502*, PH553C, and PPH50. (When using 1128 with PPH50, two 8024 adapter are required to connect PPH50 to the puller tees.)
1130	9"	1/2"	5/8-18	6"	12 lbs., 9 oz.	1035, 1040, 1041, 1042, PH172, PPH17, and 938.
V-belt pulley pulling attachments						
679	5 ⁷ / ₈ "	1 ³ / ₄	5/8-18	6	4 lbs., 4 oz.	1035, 1036, 1037, 1038, and 927.
680	10"	1 ⁵ / ₈	5/8-18	10 ¹ / ₁₆	22 lbs., 4 oz.	1039, 1040, 1041, 1042, 1047, PH172, PPH30* and 938. (When using 680 with PPH30, two 8012 adapters are required.)

Pulling attachment accessory – “Knife-like” edges of attachment fit behind bearings or other parts for easy removal with “Enforcer 55”, even if space does not permit hooking puller jaws directly to part being pulled.

No. 1128 – Spread: 5" to 12⁷/₈". Wt., 100 lbs.

* Indicates discontinued puller model.

1128-1129

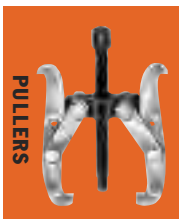
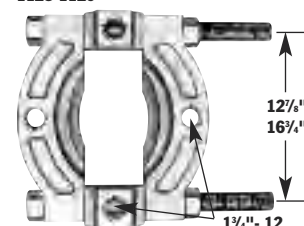

SLIDE HAMMER PULLERS

Blind hole puller set – Removal of bearings, bushings, sleeves and other friction-fitted parts from blind holes can now be accomplished with ease. Set provides selection of expanding collets $\frac{5}{16}$ " to $1\frac{3}{4}$ " I.D. Collet is placed through bore of part to be removed, then expanded with actuator pin so that lips of collet secure a positive grip for pulling. Pulling force is exerted by means of a forcing screw and bridge assembly or with a slide hammer.



Set No. 981

No. 981 – Blind-hole puller set with slide hammer, forcing screw, bridge, actuator pins, collets, and storage box. Wt., 21 lbs.

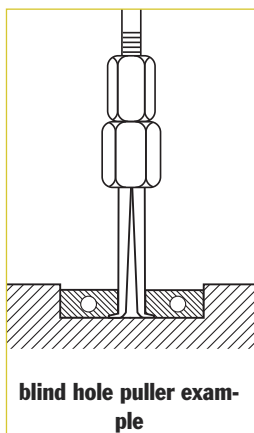

Order No.	Description	Order No.	Description
24835	Forcing Screw	28253	Actuator Pin ($\frac{3}{16}$ " dia.)
24836	Forcing Screw Nut	28256	Actuator Pin ($\frac{1}{2}$ " dia.)
22185	Hammer 2 $\frac{1}{2}$ lbs.	41331	Bridge
208627	Shank & Tee Bar Assembly	28323GY8	Metal Box
28250	Actuator Pin ($\frac{1}{8}$ " dia.)	10419	Metal Box

Order No.	Inch Range	MM Range	Order No.	Inc Range	MM Range
33856*	$\frac{5}{16}$ " to $\frac{3}{8}$ "	8 to 9.5	33861**	$\frac{3}{4}$ " to $\frac{7}{8}$ "	19.1 to 22.2
33857*	$\frac{3}{8}$ " to $\frac{7}{16}$ "	9.5 to 11.1	33862**	$\frac{7}{8}$ " to 1"	22.2 to 25.4
33858**	$\frac{7}{16}$ " to $\frac{1}{2}$ "	11.1 to 12.7	33863***	1" to $1\frac{1}{4}$ "	25.4 to 31.7
33859**	$\frac{1}{2}$ " to $\frac{5}{8}$ "	12.7 to 15.9	33864***	$1\frac{1}{4}$ " to $1\frac{1}{2}$ "	31.7 to 38.1
33860**	$\frac{5}{8}$ " to $\frac{3}{4}$ "	15.9 to 19.1	33865***	$1\frac{1}{2}$ " to $1\frac{3}{4}$ "	38.1 to 44.4

*Use with $\frac{1}{8}$ " actuator pin. **Use with $\frac{3}{16}$ " actuator pin. ***Use with $\frac{1}{2}$ " actuator pin

Slide hammer puller set – This very handy set is ideal for those close-quarter, inside pulling jobs. Very practical for pulling motor, generator, and magneto bearings. Also good for removing small-bore bushings, bearings, and oil seals.

No. SS2 – Slide hammer puller set. Wt., 5.8 lbs.

Jaw Set	Inside Spread	
	Min. (in.)	Max. (in.)
1172	$\frac{1}{2}$	2
1174	$\frac{1}{2}$	$1\frac{3}{8}$

Slide hammer puller set – This useful set contains a reversible-jaw slide hammer puller with a 2.5 lb. sliding hammer plus an assortment of special jaws (3 of each size) and adapters. In this set, you get all the versatility you demand of a slide hammer puller.

No. 1178 – Slide hammer puller set with 2.5-lb. sliding hammer. Wt., 13.8 lbs.

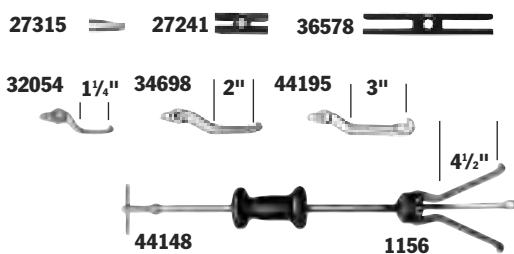

Jaw	2-Jaw Spread				3-Jaw Spread			
	Inside		Outside		Inside		Outside	
	Min. (in.)	Max. (in.)	Min. (in.)	Max. (in.)	Min. (in.)	Max. (in.)	Min. (in.)	Max. (in.)
44195	$1\frac{1}{2}$	$4\frac{1}{2}$	$\frac{3}{4}$	5	$1\frac{1}{2}$	$4\frac{3}{4}$	1	$4\frac{1}{2}$
32054	$\frac{3}{4}$	$2\frac{3}{8}$	—	—	1	$2\frac{3}{4}$	—	—
44148	$2\frac{3}{4}$	$5\frac{1}{2}$	$\frac{3}{4}$	$7\frac{1}{2}$	$\frac{3}{4}$	$6\frac{1}{4}$	1"	$6\frac{1}{2}$
34698	$1\frac{1}{4}$	$3\frac{1}{2}$	1	$4\frac{1}{2}$	$1\frac{1}{2}$	$4\frac{1}{4}$	$1\frac{1}{2}$ "	$4\frac{1}{2}$

Sliding hammers only -

No. 22185 – 2.5 lb. sliding hammer.

No. 34331 – 5 lb. sliding hammer.

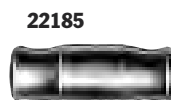

Bearing cup remover – The 7136 is perfect for pulling internal bearing cups, seals, bushings, etc. Jaw spread - $1\frac{5}{16}$ " to $3\frac{1}{4}$ ", reach to $3\frac{1}{2}$ ". Use with any slide hammer having $\frac{5}{8}$ "-18 thread (Power Team 1155, 1156 or 927 Push-Puller®).

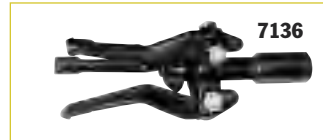

No. 7136 – Universal bearing cup remover. Wt., 1.5 lbs.

Pilot bearing pullers -These very versatile pullers are built especially for inside pulling jobs, and particularly for removing flywheel pilot bearings on machines and construction vehicles. Also very practical for pulling motor, generator and magneto bearings.

Special slide hammer puller – Ideal for pulling jobs in very close quarters, as in removal of small-bore bushings, bearings, oil seals, etc. Internal pulling attachment has jaw spread of $1\frac{1}{2}$ " to $1\frac{3}{8}$ ". Handle end has a $1\frac{1}{2}$ "- 20 thread.

Order No.	Reach (in.)	I.D. Spread		Wt. (lbs.)
		Min. (in.)	Max. (in.)	
1170	$\frac{3}{4}$	$\frac{1}{2}$	$1\frac{1}{2}$	4.9
1171	1	$\frac{7}{8}$	$2\frac{1}{8}$	4.9
1172	$1\frac{3}{4}$	$\frac{1}{2}$	2	4.9

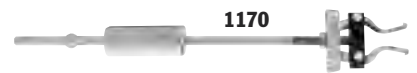

No. 1173 – Slide hammer puller. Wt., 3.5 lbs.

No. 1174 – Puller head, less slide hammer.



Basic slide hammer units – Compatible with internal pulling attachment (see page 208). Compatible with threaded adapters (see page 206-207). 24" in length, $\frac{5}{8}$ "-18 threaded end.

No. 1155 – Basic slide hammer unit with 5 lb. hammer. Wt., 7.3 lbs.

No. 1156 – Basic slide hammer unit with 2.5 lb. hammer. Wt., 4.8 lbs.

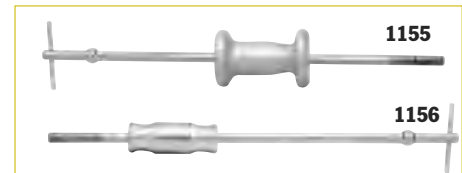

Reversible-jaw slide hammer pullers – Ideal for pulling gears, bearings, outer races, grease retainers, oil seals, etc. Two or three jaws may be used and positioned for “inside” or “outside” pulling jobs. Both have $\frac{5}{8}$ "- 18 threaded end so attachments and adapters may be used.

No. 1176 – Slide hammer puller with 2.5 lb. hammer, 27241 two-way head and 34698 jaws.

No. 1177 – Same as 1176 but with 5 lb. hammer.

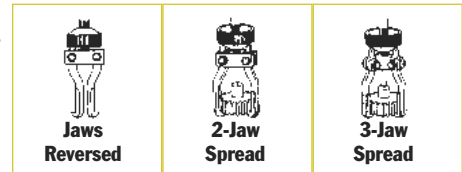

Order No.	2 Jaw Spread				3 Jaw Spread				Prod. Wt. (lbs.)	Overall Length
	Inside		Outside		Inside		Outside			
	Min. (in.)	Max. (in.)	Min. (in.)	Max. (in.)	Min. (in.)	Max. (in.)	Min. (in.)	Max. (in.)		
1176	$1\frac{1}{4}$	$3\frac{1}{2}$	1	$4\frac{1}{2}$	$1\frac{1}{2}$	$4\frac{1}{2}$	$1\frac{1}{2}$	$4\frac{1}{2}$	8	27
1177	$1\frac{1}{4}$	$3\frac{1}{2}$	1	$4\frac{1}{2}$	$1\frac{1}{2}$	$4\frac{1}{2}$	$1\frac{1}{2}$	$4\frac{1}{2}$	10.5	27

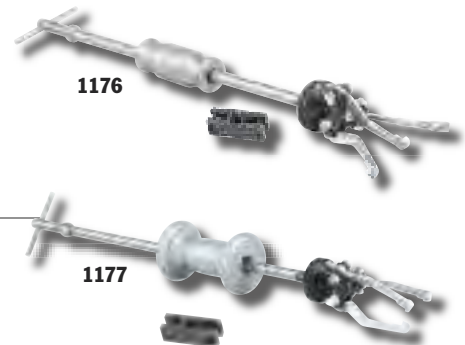

Slide hammer pullers with cup pulling attachments – These combine a basic slide hammer with No. 1152 internal pulling attachment for removing oil seals, outer races, and bearing cups from blind holes.

No. 1157 – Slide hammer puller consisting of 1156 slide hammer and 1152 internal pulling attachment.

No. 1158 – Same as 1157 but with 1155 slide hammer.

Order No.	Reach Max. (in.)	Spread Min. (in.)	Spread Max. (in.)	Prod. Wt. (lbs.)	Overall Length (in.)
1157	4	$1\frac{1}{2}$	6	9.8	28
1158	4	$1\frac{1}{2}$	6	12.3	28

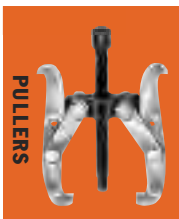



PULLER SETS



10 ton capacity Push-Puller® set – Contains three popular Power Team bar-type pullers in one versatile set, packed in a handy plastic storage case. Tools included permit damage-free pulling of gears, bearings, harmonic balancers, and other parts having tapped holes. Ideal for servicing off-road construction equipment and machinery.

Multi-purpose puller set – This new assortment of pulling tools gives you a wide range of job versatility. You get a 5 lb. slide hammer puller, hub puller, two sizes of Power Team Grip-O-Matic® jaw-type pullers, a bearing pulling attachment plus a cross-bar gear and pulley puller, all contained in a handy plastic storage case.

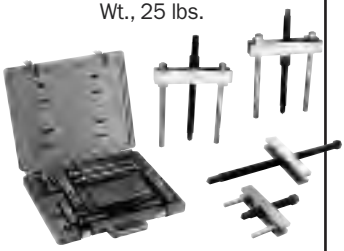
Lock-on, jaw-type puller set – Components can be assembled to create several versatile puller versions. The puller head is turned to securely lock the jaws onto the part being removed. Both a 2-way and 3-way puller head are included, plus three long-reach and three short-reach puller jaws in a plastic storage box. Easily removes gears, bearings and other press-fitted parts.

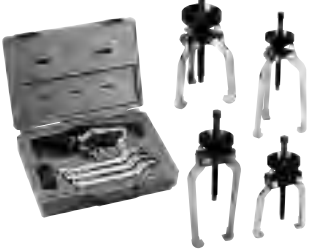
Order No.	Set Contents	Description																																		
1180 10 ton Push-Puller® set, in plastic storage case. Wt., 25 lbs. 	927	10 Ton Push-Puller®; 8 ³ / ₈ " reach, 2 ¹ / ₄ " to 7 ¹ / ₄ " spread. Comes with 6 ³ / ₄ " puller legs, other leg sizes are available separately (See page 199).																																		
	522	Gear and pulley puller; spread range when used with 1/2" cap screws: 2" to 7 ³ / ₄ ". Cap screws not included.																																		
	7393	Gear and pulley puller with standard 5 ¹ / ₂ " forcing screw, plus special 13" forcing screw. Includes two hex head cap screws, 3/8"-16 x 3" long. Spread range: 1 ¹ / ₂ " to 4 ¹ / ₄ ".																																		
1181 Multi-purpose puller set. Wt., 25 lbs. 	1177	Slide hammer puller with 5 lb. hammer, 2-way and 3-way heads. Reversible: either two or three jaws may be used to handle both "inside" and "outside" pulling jobs.																																		
	7208	Hub puller. Includes a spare locknut which permits use with No. 1177 slide hammer.																																		
	1023	2 ton combination 2- or 3-jaw Grip-O-Matic® puller. Has 3 ³ / ₈ " max. reach, 4 ³ / ₄ " max. spread.																																		
	1027	5 ton combination 2- or 3-jaw Grip-O-Matic® puller. Has 5 ¹ / ₂ " max. reach, 7" max. spread.																																		
	7393	Bar-type gear and pulley puller with 5 ¹ / ₂ " long screw. Includes two hex head cap screws, 3/8"-16 x 3" long. Spread range: 1 ¹ / ₂ " to 4 ¹ / ₄ ".																																		
1182 Jaw-type puller set. Wt., 6.8 lbs. 	<table border="1"> <thead> <tr> <th rowspan="2">Puller Jaws Order</th> <th rowspan="2">Inside* Min. (in.)</th> <th colspan="2">2-Jaw</th> <th colspan="3">3-Jaw Spread</th> <th colspan="2">Outside</th> </tr> <tr> <th>Max. (in.)</th> <th>Outside Min. (in.)</th> <th>Max. (in.)</th> <th>Inside* Min. (in.)</th> <th>Max. (in.)</th> <th>Min. (in.)</th> <th>Max. (in.)</th> </tr> </thead> <tbody> <tr> <td>44195</td> <td>1¹/₂</td> <td>4¹/₂</td> <td>3/4</td> <td>5</td> <td>1¹/₂</td> <td>4³/₄</td> <td>1</td> <td>4¹/₂</td> </tr> <tr> <td>44148</td> <td>2³/₄</td> <td>5¹/₂</td> <td>3/4</td> <td>7¹/₂</td> <td>3¹/₄</td> <td>6¹/₄</td> <td>1</td> <td>6¹/₄</td> </tr> </tbody> </table>		Puller Jaws Order	Inside* Min. (in.)	2-Jaw		3-Jaw Spread			Outside		Max. (in.)	Outside Min. (in.)	Max. (in.)	Inside* Min. (in.)	Max. (in.)	Min. (in.)	Max. (in.)	44195	1 ¹ / ₂	4 ¹ / ₂	3/4	5	1 ¹ / ₂	4 ³ / ₄	1	4 ¹ / ₂	44148	2 ³ / ₄	5 ¹ / ₂	3/4	7 ¹ / ₂	3 ¹ / ₄	6 ¹ / ₄	1	6 ¹ / ₄
	Puller Jaws Order	Inside* Min. (in.)			2-Jaw		3-Jaw Spread			Outside																										
			Max. (in.)	Outside Min. (in.)	Max. (in.)	Inside* Min. (in.)	Max. (in.)	Min. (in.)	Max. (in.)																											
	44195	1 ¹ / ₂	4 ¹ / ₂	3/4	5	1 ¹ / ₂	4 ³ / ₄	1	4 ¹ / ₂																											
	44148	2 ³ / ₄	5 ¹ / ₂	3/4	7 ¹ / ₂	3 ¹ / ₄	6 ¹ / ₄	1	6 ¹ / ₄																											

* Can be used for internal pulling tasks when used with a slide hammer.

STRONG BOX

Puller Sets

10 Ton Cap Push-Pullers,[®]
2 & 3 Jaw Pullers & Specialty
Pullers



IPS10B

10 ton capacity Strong Box puller set –

Here's a set of pullers that gives you almost unheard of versatility. This rugged, lockable metal storage cabinet contains pullers, attachments and extra puller jaws good for a variety of applications. Cabinet may be mounted on a wall, stand, or workbench.



IPS10HB

10 ton capacity hydraulic/manual puller set in Strong Box –

This lockable metal Strong Box contains both hydraulic and manual pullers, plus attachments. The rugged storage cabinet keeps the tools organized and secure from unauthorized borrowers!

- Have the puller you need on hand, when you need it, protected from unauthorized or casual borrowers.
- Almost unheard of versatility
- Rugged, lockable storage cabinet.
- Wall, stand or workbench mountable.

Order No.	Set Contents	Description
IPS10B Cabinet (25 ³ / ₄ " x 29 ¹ / ₂ " x 10") with tool board, adapter board, and tool set. Wt., 98 lbs.	927	10 ton capacity Push-Puller [®] with 6 ³ / ₄ " legs
	1027	5 ton combination 2/3-jaw puller
	1037	7 ton combination 2/3-jaw puller
	1101	15 ³ / ₄ " puller legs (pair)
	1122	Bearing pulling attachment
	1123	Bearing pulling attachment
	1152	Internal pulling attachment
	7393	Gear and pulley puller
	8005, 8006, 8007, 8010	Male/female threaded
	8013, 8015, 8019	Adapters (2 ea.)
	8035, 8037, 8038, 8039, 8040	Female threaded adapters
	8050 thru 8053	Shaft protectors
	8057 thru 8062	Step plate adapters
	43892	Long jaws for 1037 (3)
	212867	Cabinet, tool board and adapter board
IPS10HB Cabinet (25 ³ / ₄ " x 29 ¹ / ₂ " x 10") with tool board, pullers, and hydraulics. Wt., 119 lbs.	*PH103C	10 ton combination 2/3-jaw hydraulic puller
	1027	5 ton combination 2/3-jaw puller
	1042	13 ton combination 2/3-jaw puller
	1177	Slide hammer puller
	44148	3 jaws for slide hammer puller (4 ¹ / ₂ ")
	44195	3 jaws for slide hammer puller (3")
	36578	Slotted cross head for slide hammer puller
	27315	Seal hook for slide hammer puller
	1152	Internal pulling attachment (1 ¹ / ₂ " to 6" spread)
	24832	Forcing screw for 1152
	215315	Cabinet and tool board



* See page 220.

PULLER ADAPTERS

Specialty Metric

Gear and pulley pullers – Ideal for pulling many small parts having tapped holes. The Nos. 7392 and 7393 may be used with the No. 1122 pulling attachment to remove bearings, etc. Pullers include two hex head cap screws, $\frac{3}{8}$ " – 16 NC x 3" long. Spread: $1\frac{1}{2}$ "– $4\frac{1}{4}$ ". Width of puller block is $4\frac{7}{8}$ ". Cap screws are not included with the No. 522, but any cap screws up to $\frac{1}{2}$ " diameter may be used. No. 522 spread, when used with $\frac{1}{2}$ " dia. cap screws, is 2"– $7\frac{3}{4}$ ". Width of the No. 522 puller block is $8\frac{1}{4}$ ".

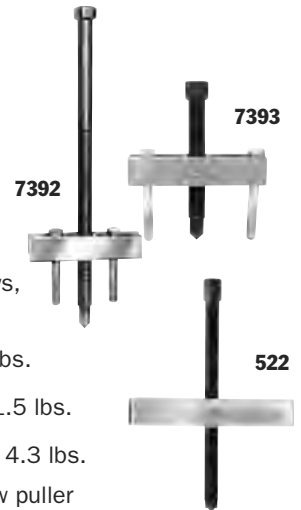

No. 7392 – Puller with $\frac{5}{8}$ "-18 x 13" long screw. Wt., 2 lbs.

No. 7393 – Puller with $\frac{5}{8}$ "-18 x $5\frac{1}{2}$ " long screw. Wt., 1.5 lbs.

No. 522 – Puller with $\frac{3}{4}$ "-16 x $11\frac{5}{8}$ " long screw. Wt., 4.3 lbs.

4-in-1 puller set – You can quickly assemble a 2- or 3-jaw puller with standard or long reach jaws.

No. PA7 – Four-In-One puller set, 7 ton capacity. Standard jaw max. reach is 5". Maximum spread is $10\frac{1}{2}$ ". Long jaw maximum reach is $8\frac{3}{4}$ ". Maximum spread is 11". Wt., 10.8 lbs.

Flange type puller – Slotted holes in puller body permit cap screws to be positioned to handle bolt-circle diameters from $1\frac{1}{2}$ " to $4\frac{5}{8}$ ".

No. 518 – Flange type puller. Includes 3 cap screws, $\frac{3}{8}$ " – 24 NF x 3" long and 3 cap screws $\frac{3}{8}$ " – 16 NC x 3" long. Forcing screw is $\frac{5}{8}$ "-18 x 5" long. Wt., 3.4 lbs.

Metric adapters – Add metric capability to your Push-Puller® legs or forcing screws! Four separate metric kits available with a variety of sizes for your Push-Puller® legs or forcing screws! Each packaged in a convenient plastic organizer case.



Order No.	Kit Contents	Female End	Male End	Length	Order No.	Kit Contents	Female End	Male End	Length
No. 8110 Male Metric Wt., 3 lbs.	8111	$\frac{5}{8}$ "-18	M6 x 1.0	$2\frac{1}{4}$ "	No. 8120 Male Metric Wt., 3 lbs.	8121	$\frac{5}{8}$ "-18	M14 x 1.5	$2\frac{1}{4}$ "
	8112	$\frac{5}{8}$ "-18	M8 x 1.0	$2\frac{1}{4}$ "		8122	$\frac{5}{8}$ "-18	M14 x 2.0	$2\frac{1}{4}$ "
	8113	$\frac{5}{8}$ "-18	M8 x 1.25	$2\frac{1}{4}$ "		8123	$\frac{5}{8}$ "-18	M16 x 1.5	$2\frac{3}{4}$ "
	8114	$\frac{5}{8}$ "-18	M10 x 1.25	$2\frac{1}{4}$ "		8124	$\frac{5}{8}$ "-18	M16 x 2.0	$2\frac{3}{4}$ "
	8115	$\frac{5}{8}$ "-18	M10 x 1.50	$2\frac{1}{4}$ "		8125	$\frac{5}{8}$ "-18	M20 x 1.5	$2\frac{3}{4}$ "
	8116	$\frac{5}{8}$ "-18	M12 x 1.25	$2\frac{1}{4}$ "		8126	$\frac{5}{8}$ "-18	M20 x 2.5	$2\frac{3}{4}$ "
	8117	$\frac{5}{8}$ "-18	M12 x 1.75	2"					

Note: The adapters in each of these sets are also available separately.

Female threaded adapters - Use these adapters on the ends of Push-Puller® forcing screws, legs, or slide hammers in the removal and installation of shafts, axles, and housings.

Set No. 8044 – consists of a set of 6 adapters (Nos. 8037-8042)



Order No.	Female End "A"	Female End "B"	Order No.	Female End "A"	Female End "B"
8035*	$\frac{1}{2}$ "-20	$\frac{5}{8}$ "-18	8040	$\frac{5}{8}$ "-18	1"-14
8036*	1"-14	1"-14	8041	$\frac{5}{8}$ "-18	$1\frac{1}{8}$ "-12
8037	$\frac{5}{8}$ "-18	$\frac{5}{8}$ "-18	8042	$\frac{5}{8}$ "-18	$1\frac{1}{4}$ "-12
8038	$\frac{5}{8}$ "-18	$\frac{3}{4}$ "-16	8043*	$\frac{5}{8}$ "-18	$1\frac{1}{2}$ "-12
8039	$\frac{5}{8}$ "-18	$\frac{7}{8}$ "-14			

Note: All adapters available separately.

*Not included in set No. 8044. Order separately.

Male-female threaded adapters – These adapters are used on ends of Push-Puller® legs, with forcing screws or slide hammers to assist in pulling shafts, bearing caps, pinions, and many other parts.

Order No.	Female End	Male End	Length	Order No.	Female End	Male End	Length
8000	5/8"-18	1/4"-20	2 1/4"	8015	5/8"-18	3/4"-10	2 1/4"
8001	5/8"-18	5/16"-18	2 1/4"	8016	1"-14	3/4"-10	2 1/2"
8002	5/8"-18	7/16"-14	2 1/4"	8017	5/8"-18	7/8"-14	2 1/4"
8003	5/8"-18	7/16"-20	2 1/4"	8018	5/8"-18	7/8"-9	2 1/4"
8004	5/8"-18	3/8"-24	2 1/4"	8019	5/8"-18	1"-14	2 1/4"
8005	5/8"-18	3/8"-16	2 1/4"	8020	1"-8	5/8"-18	3"
8006	5/8"-18	1/2"-20	2 1/4"	8021	1"-8	1"-14	3"
8007	5/8"-18	1/2"-13	2 1/4"	8022	5/8"-18	1/8" pipe	2 1/4"
8008	5/8"-18	9/16"-18	2 1/4"	8023	1 1/4"-12	1"-14	4 1/2"
8009	5/8"-18	9/16"-12	2 1/4"	8024	1 1/4"-12	1 3/4"-12	4 1/2"
8010	5/8"-18	5/8"-11	2 1/4"	8025	1 1/4"-7	5/8"-18	4"
8011	1"-14	5/16"-11	2 1/2"	8027	1 1/4"-7	1"-14	4"
8012	1"-14	5/8"-18	3 3/16"	8028	1 5/8"-5 1/2	1"-8	4"
8013	5/8"-18	3/4"-16	2 1/4"	8029	1 5/8"-5 1/2	1"-14	4"
8014	1"-14	3/4"-16	2 1/2"				

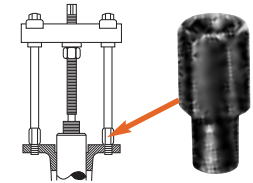

Fed. Spec.: GGG-P-00781-D

Note: Nos. 8000-8029 – each sold individually.

Step plate adapter sets – Power Team step plate adapters are necessary for pulling and installing bearings, gears, or other parts on hollow shafts or housings. Puller screw forces against step plate adapter, as shown at right. May be used with Power Team jaw-type pullers, Push-Pullers® and shop presses.

Set No. 8075 – set of 11 adapters (Nos. 8057-8067).

Set No. 8076 – set of 6 adapters (Nos. 8068-8073).

Order No.	Set No. 8075		Order No.	Set No. 8075		Order No.	Set No. 8076	
	Dia. "A" (in.)	Dia. "B" (in.)		Dia. "A" (in.)	Dia. "B" (in.)		Dia. "A" (in.)	Dia. "B" (in.)
8057	1	3/4	8063	1 7/8	1 5/8	8068	2 5/8	2 1/8
8058	1 1/8	7/8	8064	2	1 5/8	8069	2 3/4	2 1/4
8059	1 1/4	1	8065	2 1/8	1 3/4	8070	2 7/8	2 3/8
8060	1 3/8	1 1/8	8066	2 3/8	1 7/8	8071	3	2 1/2
8061	1 5/8	1 1/4	8067	2 1/2	2	8072	3 1/4	2 3/4
8062	1 3/4	1 3/8				8073	3 1/2	3

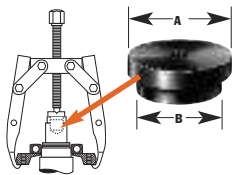

Shaft protector set -- Power Team shaft protectors are designed to protect shaft centers from distortion when extreme pressures are applied with jaw-type pullers or Push-Pullers®. Shaft protectors are inserted between the end of the puller screw and the shaft.

Set No. 8056 – Set of 6 shaft protectors (Nos. 8050 thru 8055).

Order No.	"A" (in.)	"B" (in.)	"C" (60°) (in.)	"D" (60°) (in.)	Order No.	"A" (in.)	"B" (in.)	"C" (60°) (in.)	"D" (60°) (in.)
8050	1 1/2	3/4	3/8	7/16	8053	3/4	3/4	1/4	1/4
8051	1 1/4	3/4	3/8	3/8	8054	5/8	5/8	3/4	1/4
8052	1	3/4	3/8	5/16	8055	5/8	5/8	3/16	3/16

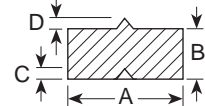
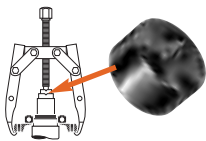

CAUTION: All the items shown may not withstand the full tonnage of the pullers they may be used with. Refer to page 195.

PULLER SETS

Manual
10 & 17½ Ton

10 ton manual puller set – This puller set is just what you need for removing gears, bearings, etc. Includes pullers, attachments, and many accessories.



IPS10M

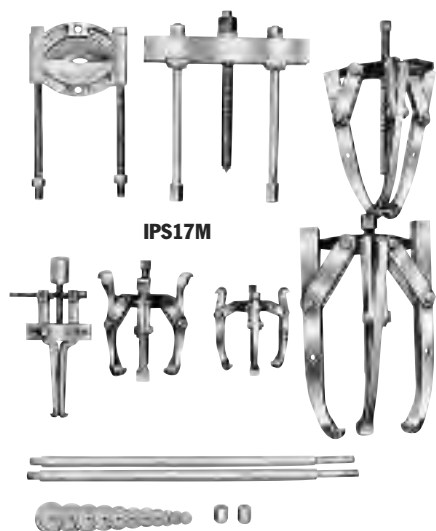

IPS17M

17½ ton manual puller set – The pullers and accessories in this set can be used for hundreds of applications including quick and easy maintenance involving removal and replacement of press-fit parts.

Manual Puller Set No.
Order No.

IPS10M
10 ton capacity
Wt., 53 lbs.

Set
Contents Pullers

927 10 ton capacity Push-Puller® with 6¾" legs
1023 2 ton combination 2/3-jaw puller
1026 5 ton combination 2/3-jaw puller
1027 5 ton combination 2/3-jaw puller
1037 7 ton combination 2/3-jaw puller
1178 Slide hammer set

Set
Contents Accessories

8075 Step plate adapter set
8044 Female threaded adapter set
8035 Female threaded adapter: ½"-20 x ¾"-18
1151 Bearing cup pulling attachment
1121 Bearing pulling attachment
1122 Bearing pulling attachment
1123 Bearing pulling attachment
1101 15½" long puller legs for 927 (pr.)

IPS17M
17½ ton capacity
Wt., 116 lbs.

938 17½ ton capacity Push-Puller® with 9½" legs
1027 5 ton combo 2/3-jaw puller, with long jaws
1037 7 ton combination 2/3-jaw puller
1041 13 ton combination 2/3 jaw puller
1045 17½ ton 3-jaw puller

8075 Step plate adapter set
1105 22½" legs for 938
1130 Bearing pulling attachment
1151 Bearing cup pulling attachment
8038 Female adapter: ⅝"-18 F. x ¾"-16 F. (2)



PROTECTIVE BLANKETS

and Security Chests

PB1230C



Power Team protective blanket – Our blankets are designed to contain broken or flying parts from the most extreme forces, thus resulting in a much safer work environment.

Testing results – In our lab, this style of blanket held the parts of a necked-down grade 8 bolt, which shattered in a 100 ton center-hole hydraulic cylinder. The blanket sustained no visible damage when shot with a force and impact that shattered safety glasses!

- Made of see-through, high-tensile, tear resistant material.
- Effectively contain broken or flying parts from the most extreme pulling, pressing, pushing or stressing forces.
- Ideal for use with pullers and forcing presses.

PROTECT YOURSELF AND YOUR EQUIPMENT.

- Unlike rigid, fixed guards, these blankets can be wrapped and strapped around a job.
- The clear protective blankets allow you to visually monitor the job from start to finish.
- Protective blankets come in a carrying/storage pouch to reduce aging caused by prolonged exposure to light.

Order No.	Size (in.)	Number of Straps	Wt. (lbs.)
PB1230C	12 x 30	2	2.8
PB2036C	20 x 36	2	4.2
PB2860C	28 x 60	3	9.3
PB3372C	33 x 72	3	11.7
PB44120C	44 x 120	4	24.2
PB51156C	51 x 156	4	34.4



Note: Custom sizes are available on a special order basis. Please consult factory.

Job-site and maintenance security chests – Protect your valuable tools and equipment from theft and weather. When the day's work is finished, you want to rest assured that your tools

and equipment will be present the next day. In these times, security is a real concern. These rugged, lockable chests are the answer that many of our customers have been asking for.



- Rugged, 16 gauge steel construction with fully arc welded seams for extra strength and weather protection.
- Full length piano hinges, mating cover to body, protect against weather and theft.
- Single or double latch security tabs for padlocks.
- Mechanical cover supports, two 2¹/₄" high skids.
- Fold-down 3/4" pipe handles on each end of chest.
- Pre-drilled for optional casters, which enhance mobility.
- Durable baked enamel finish.

Order No.	Dimensions				Storage		Optional Caster Wheels
	A (in.)	B (in.)	C (in.)	D (in.)	Cap. (cu. ft.)	Wt. (lbs.)	
MB5	34 ³ / ₄	14	32	19	5	66	No. 251646 – Set of four 4" casters (two swivel and two rigid). Furnished with mounting screws. Wt., 12.5 lbs.
MB8	39 ³ / ₄	19	42	19	8.8	90	
MB16	49 ³ / ₄	24	48	24	16	126	No. 251647 – Set of four 6" casters (two swivel and two rigid). Furnished with mounting screws. Wt., 15.3 lbs.



HYDRA GRIP-O-MATIC®

Use with

2 & 3 Jaw Pullers
6, 8, 11 & 30 Ton



PH82K



PH303C

PH63C

- You get the world's most copied puller design; the harder the pulling force, the tighter the jaws grip for secure holding force.
- Power Team pullers are tested for top performance and reliability at maximum capacity and jaw spread.
- Removing a wide variety of gears, bearings, bushings, pulleys and other press-fitted parts becomes a routine task.
- Easily metered release valve control knob.
- Spring loaded live centering cone.
- Bladder type oil reservoir.
- Rapid adjustment.
- Use with 2 or 3 jaws.
- Supplied with a sturdy storage/carrying case.
- Features Power Team's exclusive Marathon Limited Lifetime Warranty

Hydra Grip-O-Matic® pulling system - These pullers are ideal for pulling a wide variety of press-fitted parts including bushings, bearings, wheels, gears and pulleys. Grip-O-Matic® pullers have been rigorously tested for top performance and reliability. PH82K is a complete pulling system which includes a hydraulic power module, 2-way puller head, jaws, legs and bearing splitter attachment; all contained in a convenient carrying case.



HST11S

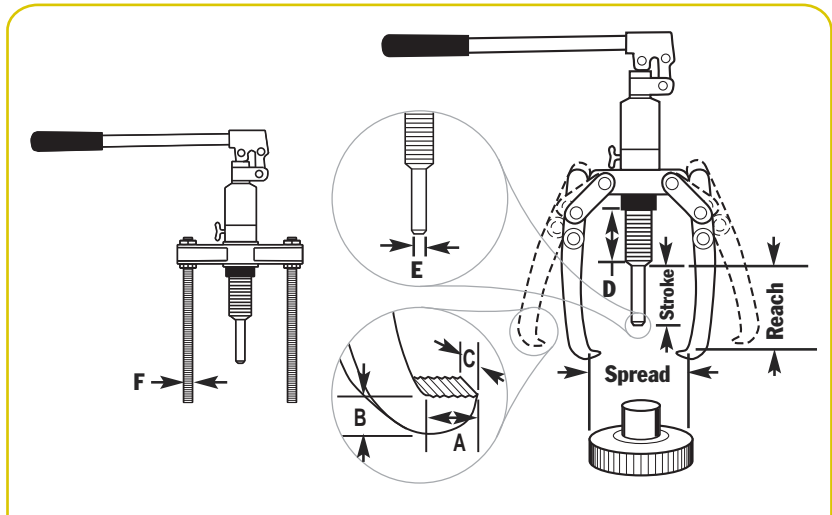

PULLERS

Cyl. Cap. (tons)	Order No.	Reach		Min. Reach (in.)	Max. Studs (in.)	Spread Jaws (in.)	Stroke (in.)	A (in.)	B (in.)	C (in.)	D (in.)	E (in.)	F (in.)	Wt. (lbs.)
		Studs (in.)	Jaws (in.)											
6	PH63C	—	6	—	—	7 ⁷ / ₈	3 ¹ / ₈	7 ⁷ / ₁₆	1 ¹ / ₄	7 ⁷ / ₈	3 ¹ / ₄	7 ⁷ / ₈	—	10.8
8	PH83C	—	7 ¹ / ₂	—	—	9 ¹³ / ₁₆	3 ¹ / ₈	7 ⁷ / ₁₆	3 ³ / ₈	1	3 ¹ / ₄	1 ¹ / ₈	—	14.5
11	PH113C	—	9	—	—	11	3 ¹ / ₈	9 ⁹ / ₁₆	3 ³ / ₈	1 ¹ / ₈	3 ¹ / ₄	1 ¹ / ₈	—	17.6
30	PH303C	10 ¹ / ₂	14 ³ / ₄	—	—	21 ¹ / ₄	4 ¹ / ₄	1 ¹ / ₁₆	1 ⁷ / ₁₆	1 ¹ / ₂	6 ¹¹ / ₁₆	2 ¹ / ₈	5 ⁵ / ₈ -18 UNF	112
8	PH82K	10 ¹ / ₂	8 ⁵ / ₃₂	4 ²⁹ / ₃₂	11 ⁵¹ / ₆₄	9 ²¹ / ₃₂	3 ¹ / ₈	2 ³ / ₆₄	1	5 ⁵ / ₈	3 ¹ / ₄	7 ⁷ / ₈	5 ⁵ / ₈ -18 UNF	35
11	HST11S*	—	5 ²⁹ / ₃₂	—	—	16 ¹ / ₈	3 ¹ / ₈	—	—	—	3 ¹ / ₄	7 ⁷ / ₈	—	32

* (Max bar size 2.3622" or 60 mm)



K82



Hydra Grip-O-Matic® puller accessory kits

K82 accessory kit for the Hydra-Grip-O-Matic® puller No. PH83C. Includes 2-way puller head, 2 jaws, 2 threaded legs and sturdy carrying/storage case.

No. K83 – Accessory kit for PH83C Grip-O-Matic® hydraulic puller. K83 2/3 way head accessories kit for a Hydra Grip-O-Matic® puller No. PH83C. Includes 2/3 way puller head, 3 jaws, 3 threaded legs (5/8-18 thread) and sturdy carrying/ storage case. Also can be used with 1123, 1124, 1130 pulling attachments.



K83



Puller Accessory converts PH113C into a Hydraulic Straightening Tool –

Portable...Good for straightening mechanical shafts, round bars, etc. Simply remove pump and cylinder from puller head and insert them into the straightening tool accessory. This product is widely used in steel mills, wire roll companies, wire extruding companies, textile industry, and any straightening situation where portability and power are required. Contoured heat-treated shaft adapter included.

No. HST11 – Spread: 3¹/₂" to 16¹/₈", Reach: 5²⁹/₃₂". Wt., 21 lbs.

Long jaw set for PH83C and PH113C Grip-O-Matic® pullers – This long jaw set is the perfect addition to the PH83C or PH113C Grip-O-Matic® hydraulic pullers. The extra long jaws give you the added capability of pulling a wider variety of parts. Jaw capacity is 8 tons when used with the PH83C puller; 15 tons when used with the PH113C puller.

No. 1188 – Spread: 11" to 12¹/₂", Reach: 12¹/₂".

HST11



Shaft adapter included



PULLERS

Hydraulic

5, 10, 17 1/2, 30 & 50 Ton

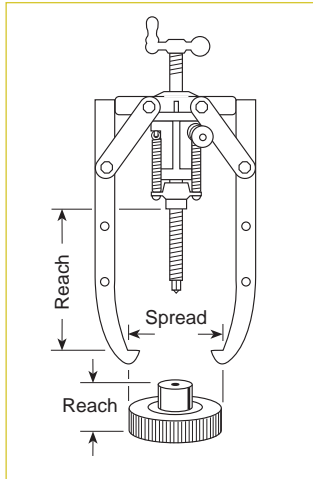

5 ton capacity, 2/3 jaw puller –

No. PH53C – Combination 2-jaw/3-jaw puller set. Includes 1057 5 ton puller, RPS55 hydraulic set (C55C cylinder, P12 10,000 psi hand pump, fittings, coupler, and 6 ft. hose), and 309874 pushing adapter. Wt., 20 lbs.

No. PH53CR – Combination 2-jaw/3-jaw puller set. Includes 1057 5 ton puller, C55C cylinder, and 309874 pushing adapter. Wt., 12 lbs.

No. 1057 – 5 ton cap. 2-jaw/3-jaw puller only. Wt., 7.8 lbs.

- Remove gears, bearings, and other press-fitted parts with speed and ease.
- Broad capacity range of 5, 10, 17 1/2, 30 and 50 tons.
- 5 and 10 ton sets include: single-acting, spring return hydraulic cylinder with hose, coupler and dust cap; single-speed hydraulic hand pump; puller.
- 17 1/2, 30 and 50 tons sets include: Power-Twin® single acting, spring return hydraulic cylinder with hose, coupler and dust cap; single-speed hydraulic hand pump; puller, adjusting screw and crank.
- Hydraulic cylinder of all models is readily removable from puller for use with pump in other hydraulic applications. You get maximum maintenance versatility for your investment.

Fed. Spec.: GGG-P-00781-D

Available components -

No. 309874 – 5/8" diameter pushing adapter. (Included with PH53C and PH53CR hydraulic puller sets.) Wt., 3 lb.

No. 309875 – 7/8" diameter pushing adapter. Wt., .8 lb.

No. 47997 – 2-way/3-way puller head. (Can be used to convert No. 1038 7 ton manual puller into a 5 ton hydraulic puller.) Wt., 2.3 lbs.

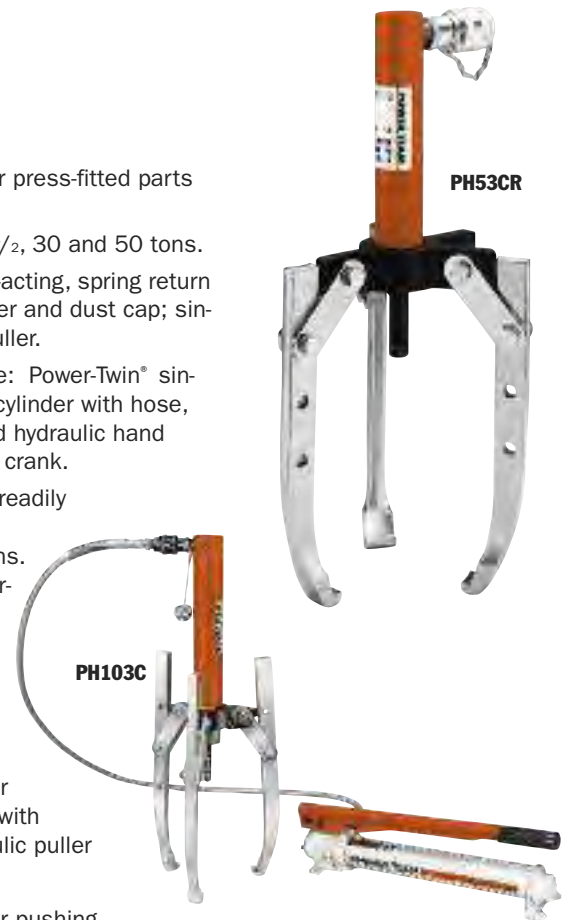

10 ton capacity, 2/3 jaw puller -

No. PH103C – Combination 2-jaw/3-jaw puller; 10 ton capacity. Set includes 1060 10 ton puller, RPS1010 cylinder and pump set, 202179 threaded adapter, and 34602 pushing adapter. Wt., 52 lbs.

No. PH103CR – Combination 2-jaw/3-jaw puller, 10 ton capacity. Set includes 1060 10 ton puller, 202179 threaded adapter, 34602 pushing adapter, and C1010C cylinder only. (Pump and hose not included.) Wt., 32 lbs.

No. 1060 – Combination 2-jaw/3-jaw puller only; 10 ton capacity. (Cylinder and pump set, hose, coupler, and adapter No. 202179 not included.) Wt., 17 lbs.

NOTE: This puller may be used with any 10 ton single-acting cylinder having a 2 1/4"-14 straight collar thread.





17½ ton capacity, 2-jaw puller –

No. PH172 – 2-jaw puller with RT172 center-hole Power-Twin® cylinder, cylinder half coupler, P55 pump, 6-ft. hose, hose half coupler, 1"– 8 x 20" long adjusting screw, and adjusting crank. Wt., 61 lbs.

No. 1064 – Puller only. (Cylinder, pump, hose, coupler, screw, and crank not included). Wt., 22 lbs.

17½ ton capacity, 3-jaw puller –

No. PH173 – 3-jaw puller with RT172 center-hole Power-Twin® cylinder, cylinder half coupler, P55 pump, 6-ft. hose, hose half coupler, 1"– 8 x 20" long adjusting screw, and adjusting crank. Wt., 75 lbs.

No. PH173R – 3-jaw puller with screw and crank, and RT172 center-hole twin cylinder. Wt., 56 lbs.

No. 1066 – Puller only. (Cylinder, pump, hose, coupler, screw, and crank not included). Wt., 36 lbs.

30 ton capacity, 3-jaw puller –

No. PH303 – 3-jaw puller with RT302 center-hole Power-Twin® cylinder, cylinder half coupler, P55 pump, 6-ft. hose, hose half coupler, 1¼"– 7 x 24" lg. adjusting screw, and adjusting crank. Wt., 149 lbs.

No. PH303R – 3-jaw puller with screw and crank, and RT302 center-hole twin cylinder. Wt., 130 lbs.

No. 1074 – Puller only. (Cylinder, pump, hose, coupler, screw, and crank not included). Wt., 90 lbs.

50 ton capacity, 3-jaw puller –

No. PH503 – 3-jaw puller with RT503 center-hole Power-Twin® cylinder, cylinder half coupler, P55 pump, 6-ft. hose, hose half coupler, 1⅝"– 5½ x 30⅜" long adjusting screw, and adjusting crank. Wt., 286 lbs.

No. 1080 – 3-jaw puller only. (Cylinder, pump, hose, coupler, screw, and crank not included). Wt., 191 lbs.

PULLER ONLY

Order No.	Cap. (Tons)	Jaws	Jaw Reach (in.)	Jaw Spread (in.)	Jaw Thickness (in.)	Jaw Width (in.)	Wt. (lbs.)
1057	5	2/3	8¾	11½	11/32	63/64	7.8
1060	10	2/3	15	17	9/16	63/64	17
1064	17½	2	11½	16	13/16	19/32	22
1066	17½	3	11½	20	13/16	19/32	36
1074	30	3	197/16	34	11/8	15/8	90
1080	50	3	275/8	44	113/32	17/8	191

CAUTION: Always use a 3-jaw puller where clearance permits in order to provide a more stable setup and a more even pulling force.



PUSH-PULLERS®

Hydraulic

17½, 30-50 Ton

The power to make impossible jobs become routine.

- Can apply a hydraulic pushing or pulling force, depending on how the puller is set up.
- Each unit includes perfectly matched hydraulic components that can be detached from the Push-Puller® for other tasks requiring dependable Power Team power; assuring maximum return on your investment.
- Optional leg kits adapt your Push-Puller® to extra long or extra short reach.
- A wide variety of threaded adapters, bearing pulling attachments and internal pulling attachments can be used in combination with our Push-Pullers®.

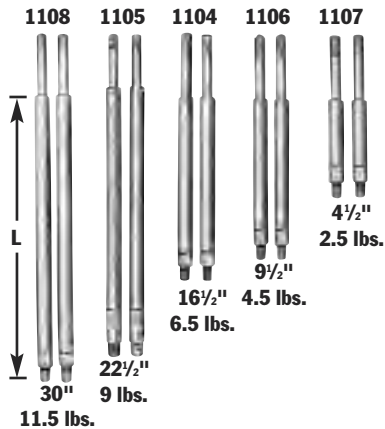

NOTE: L = leg length: 4½", 9½", 16½", 22½", 30"; subtract 4⅞" from leg length to determine reach when using leg end caps.

ASSEMBLING THE TOOL TO APPLY PUSHING OR PULLING FORCE:

1. Determine if you want the tool's forcing screw to push or pull.
2. To exert pushing force, the forcing nut is installed beneath the cross block, as shown on left.
3. To cause the forcing screw to pull, the forcing nut is placed on top of the cross block.
4. The sliding plates must always be placed on the opposite side of the cross block from the forcing nut.

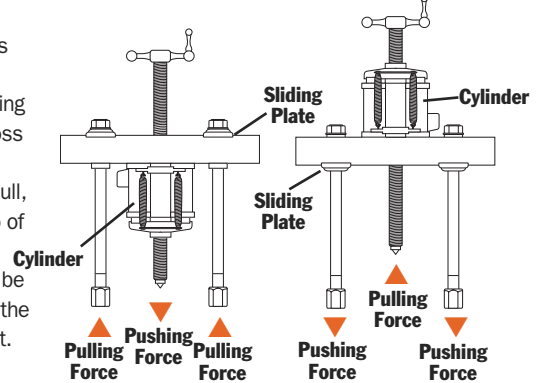

Selection and capacity rating – Each Push-Puller's specified tonnage "capacity" is determined using its standard legs in tension. Using longer legs, or a setup in which the legs are in compression, will reduce the "capacity". Always select the largest "capacity" puller and the shortest legs that will fit the job.

Power Twin® cylinder – This unique center-hole cylinder powers each Push-Puller®. Puller screw runs right between the twin spring cylinder. A basic head allows you to change from a tapped hole to a plain hole by merely changing the head insert.

17½ ton capacity Push-Puller® –

No. PPH17 – Push-Puller® with RT172 center-hole Power Twin® cylinder, cylinder half coupler, P55 pump, 9767 6-ft. hose, 9798 hose half coupler, 16½" legs, 24827 leg ends, 1"-8 x 20" lg. adjusting screw and adjusting crank. Wt., 59 lbs.

No. PPH17R – Same as above, but without P55 pump, 9767 6-ft. hose and 9798 hose half coupler. Wt., 40 lbs.

No. 1062 – Puller only. (Cylinder, pump, hose, coupler, screw and crank not included.) Wt., 20 lbs.

USE WITH:

Bearing pulling attachments: **Nos. 1124 and 1130.**

Pulley pulling attachment: **No. 679.**

Internal pulling attachment: **No. 1154.**

Legs: **Nos. 1104, 1105, 1106, 1107 and 1108** - Pair of legs for 17½-ton "capacity" Push-Puller®.

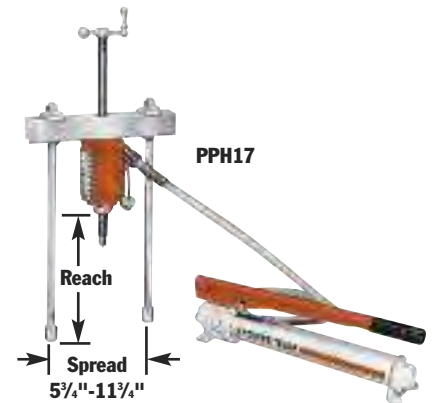

Leg Ends – Upper leg ends are threaded ¾"-16. Lower leg ends are threaded ⅝"-18" lg.



30 ton capacity Push-Puller® -

No. PPH30 – Push-Puller® with RT302 center-hole Power Twin® cylinder, cylinder half coupler, P55 pump, 9767 6-ft. hose, 9798 hose half coupler, 18" legs, 28390 leg ends, 1¹/₄"-7 x 24" lg. adjusting screw and adjusting crank. Wt., 102 lbs.

No. PPH30R – Same as above, but without P55 pump, 9767 6-ft. hose and 9798 hose half coupler. Wt., 82 lbs.

No. 1070 – Puller only. (Cylinder, pump, hose, coupler, screw and crank not included.) Wt., 42 lbs.

USE WITH:

Bearing pulling attachments. **No. 680** (Use two 8012 adapters to connect to puller.)

Pulley pulling attachment: **No. 679.**

Internal pulling attachment: **No. 1166.**

Legs: **Nos. 1109, 1110 and 1111** - Pair of legs for 30 ton "capacity" Push-Puller®.

50 ton capacity Push-Puller® -

No. PPH50 – Push-Puller® with RT503 center-hole Power Twin® cylinder, cylinder half coupler, P55 pump, 9767 6-ft. hose, 9798 hose half coupler, 24" legs, 1⁵/₈"-5¹/₂ x 30³/₈" lg. adjusting screw and adjusting crank. Wt., 201 lbs.

No. PPH50R – Same as above, but without P55 pump, 9767 6-ft. hose and 9798 hose half coupler. Wt., 181 lbs.

No. 1076 – Puller only. (Cylinder, pump, hose, coupler, screw and crank not included.) Wt., 106 lbs.

USE WITH:

Bearing pulling attachments: **Nos. 1128 and 1129.**

Legs: **Nos. 1112 and 1113** - Pair of legs for 50 ton "capacity" Push-Puller®.

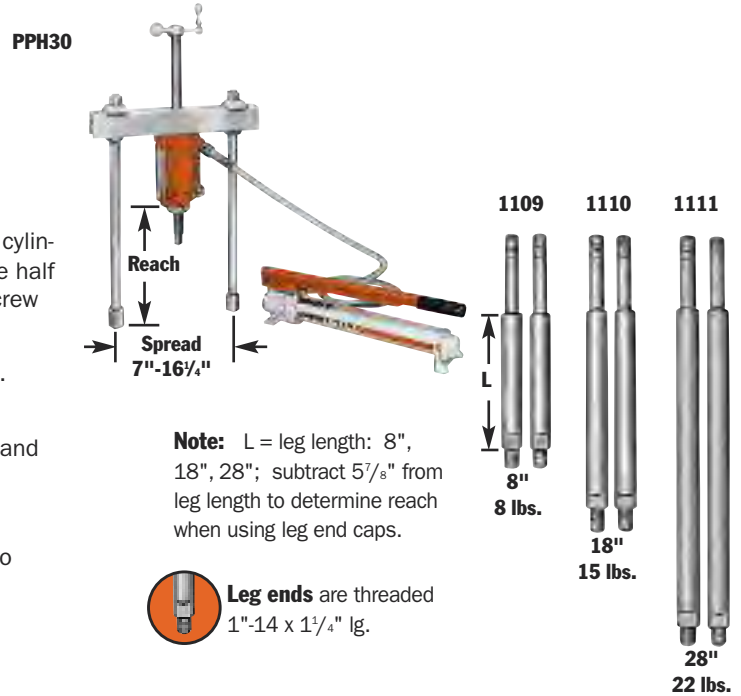

Note: L = leg length: 8", 18", 28"; subtract 5⁷/₈" from leg length to determine reach when using leg end caps.



Leg ends are threaded 1"-14 x 1¹/₄" lg.

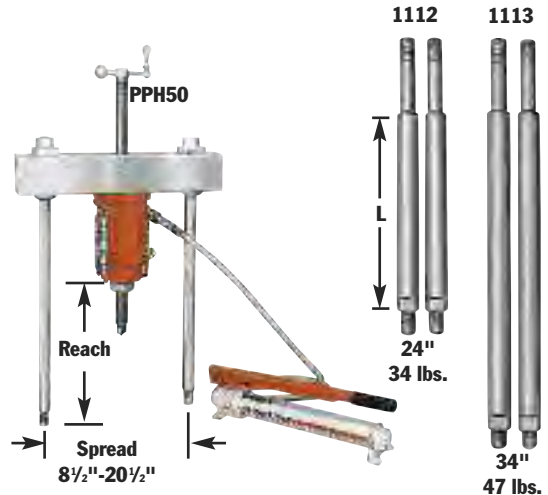

Leg ends are threaded 1¹/₄"-12 x 1³/₄" lg.



PULLER SETS

17¹/₂, 30 & 50 Ton



Wooden storage box No. 3084350R9 is included with the sets listed on this page. 36" L x 17¹/₂" W x 14" D
Metal storage boxes also available (see page 209).



17¹/₂ ton hydraulic puller set - This set includes a 3-jaw puller and a Push-Puller[®]. Ideal for heavy duty applications; put this set to work wherever large gears, bearings, wheels, pulleys, etc. are found.

No. IPS17H – 17¹/₂ ton capacity hydraulic puller set. Includes hydraulics, pullers, wooden storage box and accessories listed below. Wt., 137 lbs.

No. DB17H – Board for storing IPS17H set. Must be ordered separately. Size 5/8" x 4' x 4'. Wt., 30 lbs.



PULLERS

17¹/₂ ton hydraulic master puller sets

– Having this Power Team puller set at your fingertips will not only reduce your downtime, but also increase your profits.

No. IPS17 – 17¹/₂ ton capacity puller set. Includes hydraulics, pullers, wooden storage box and accessories listed below. Wt., 191 lbs.

No. IPS17B – Puller set with MB5 metal box. Wt., 213 lbs.



Set Contents	Hydraulics	Set Contents	Accessories
P55	Single-stage hyd. hand Pump assembly	1154	Bearing cup pulling attach
RT172	17 ¹ / ₂ ton cylinder with threaded insert	1122	Bearing pulling attachment
9798	Hose half coupler	1123	Bearing pulling attachment
9767	Hydraulic hose – 6'	1130	Bearing pulling attachment
9670	Tee adapter	Threaded Adapters	
9059	Pressure gauge	679	V-belt pulley puling attachment
Pullers		8005	5/8" – 18 F. x 3/8" – 16 M. (2)
1062	17 ¹ / ₂ ton cap. Push-Puller [®] with 16 ¹ / ₂ " legs	8006	5/8" – 18 F. x 1/2" – 20 M. (2)
24814	Speed crank	8007	5/8" – 18 F. x 1/2" – 13 M. (2)
32118	Adjusting screw	8010	5/8" – 18 F. x 5/8" – 11 M. (2)
201923	Pushing adapter	8013	5/8" – 18 F. x 3/4" – 16 M. (2)
1105	22 ¹ / ₂ " legs (pr)	8015	5/8" – 18 F. x 3/4" – 10 M. (2)
1066	17 ¹ / ₂ ton 3-jaw hyd. puller	8017	5/8" – 18 F. x 7/8" – 14 M. (2)
1027	Combination 2/3-jaw puller	8018	5/8" – 18 F. x 7/8" – 9 M. (2)
41224	17 ¹ / ₂ ton 2-jaw puller head	8019	5/8" – 18 F. x 1" – 14 M. (2)
24832	Puller screw	8020	1" – 8 F. x 5/8" – 18 M. (1)
1037	Combination 2/3-jaw puller	8021	1" – 8 F. x 1" – 14 M. (1)
1041	Combination 2/3-jaw puller	8044	Female threaded adapter set
28228	Cylinder cap	8038	5/8" – 18 F. x 3/4" – 16 F. (2)
		8056	Set of 6 shaft protectors (8050-8055)
		8075	Set of 11 adaptors (8057-8067)

Set Contents	Hydraulics	Set Contents	Accessories
P55	Single-stage hydraulic hand pump assembly	1154	Bearing cup pulling attach.
RT172	17 ¹ / ₂ ton cylinder with threaded insert	1130	Bearing pulling attachment
9798	Hose half coupler	1105	22 ¹ / ₂ " legs (pr)
9767	Hydraulic hose – 6'	24814	Speed crank
9670	Tee adapter	28228	Screw cap
9059	Pressure gauge	32118	Adjusting screw
Pullers		201454	Pushing adapter
1062	17 ¹ / ₂ ton cap. Push-Puller [®] with 16 ¹ / ₂ " legs	41224	2-jaw head for 1066
1066	17 ¹ / ₂ ton 3-jaw hyd. puller	Threaded Adapters	
		8020	1" – 8 F. x 5/8" – 18 M. (1)
		8038	5/8" – 8 F. x 3/4" – 16 F. (1)

30 ton capacity puller set – Just what you need for those big jobs. Not only do you get a 30 ton hydraulic Push-Puller®, you also get a 2-jaw and 3-jaw hydraulic puller. Plus, many popular accessories and the hardware to tackle the big jobs right away.

No. IPS30H – 30 ton capacity hydraulic maintenance puller set. Includes hydraulics, pullers, wooden storage box and accessories listed below. Wt., 330 lbs.



Set Contents	Hydraulics	Set Contents	Pullers
P55	Single-stage hydraulic hand pump assembly	1074	30 ton, 3-jaw hyd. puller
RT302	30 ton cylinder with threaded insert	41226	2-way head for 1074
9798	Hose half coupler	1070	30 ton cap. hydraulic Push-Puller® with 18" legs
9767	Hydraulic hose – 6'	1111	28" legs for 1070
9670	Tee adapter	27198	Speed crank
9059	Pressure gauge	28229	Screw cap
Accessories		34510	Pushing adapter
8036	Female threaded adapters 1" – 14F. x 1" – 14F. (2)	34758	Adjusting screw
1166	Bearing cup pulling attach.		
1127	Bearing pulling attachment		

50 ton capacity puller set - For those really big jobs, this 50 ton puller set is what you need. Just think of the jobs you can do with a 50 ton hydraulic Push-Puller®, a 2-jaw and a 3-jaw puller, both with a 50 ton capacity. Of course, you also get many versatile accessories and attachments.

No. IPS50H – 50 ton capacity hydraulic maintenance puller set. Includes hydraulics, pullers, wooden storage box and accessories listed below. Wt., 576 lbs.

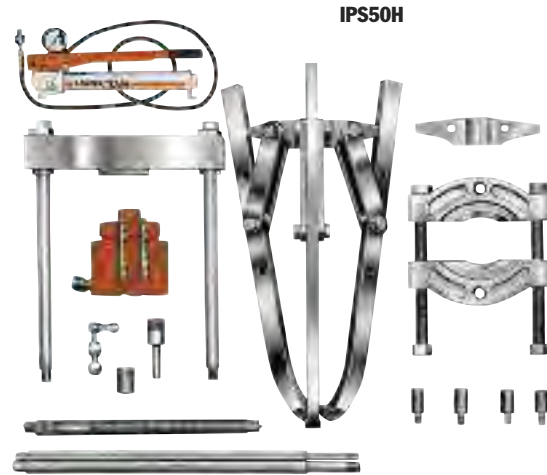

CAUTION: All the items shown may not withstand the full tonnage specified. Example: When an accessory with a 1 ton capacity is used with a 7 ton puller, the setup can be used only at a force of 1 ton.

Order No.	Hydraulics	Order No.	Pullers
P55	Single-stage hydraulic hand pump assembly	1080	50 ton, 3-jaw hyd. puller
RT503	50 ton cylinder with threaded insert	50449	2-way head for 1080
9798	Hose half coupler	1076	50 ton cap. hydraulic Push-Puller® with 24" legs
9767	Hydraulic hose – 6'	1113	34" legs for 1076
9670	Tee adapter	29595	Speed crank
9059	Pressure gauge	28230	Screw cap
Threaded Adapters		34755	Pushing adapter
8024	1 1/4" – 12F. x 1 3/4" – 12M. (2)	32698	Adjusting screw
8028	1 5/8" – 5 1/2 F. x 1" – 8M.	Accessories	
8029	1 5/8" – 5 1/2 F. x 1" – 14M.	1128	Bearing pulling attachment



PULLER SETS

Hydraulic

17 1/2 & 30 Ton

17 1/2 & 50 Ton



Note: Wooden storage box No. 3084360R9 is provided with this set.
40"L x 17"H x 24"D
Metal storage boxes also available (see page 209).



2-jaw puller reaches through spokes of gear to grip hub. Hand pump supplies hydraulic power.



Flexible coupler is removed from electric motor shaft with 2-jaw puller.



Typical setup for removing sprocket drive pinion shaft. Puller screw is attached to shaft by threaded adapter. Shaft is now ready to be pulled out hydraulically.



PULLERS

IPS3017

17 1/2 and 30 ton capacity puller sets

– These heavy-duty maintenance sets will more than pay for themselves, especially in saving you costly damage to parts. This set lets you tackle hundreds of applications where pushing and pulling are required.

No. IPS3017 – 17 1/2 and 30 ton capacity manual and hydraulic puller set. Includes hydraulics, pullers, and accessories listed below. Wt., 537 lbs.

No. IPS3017B – Puller set with MB8 metal box. Wt., 563 lbs.

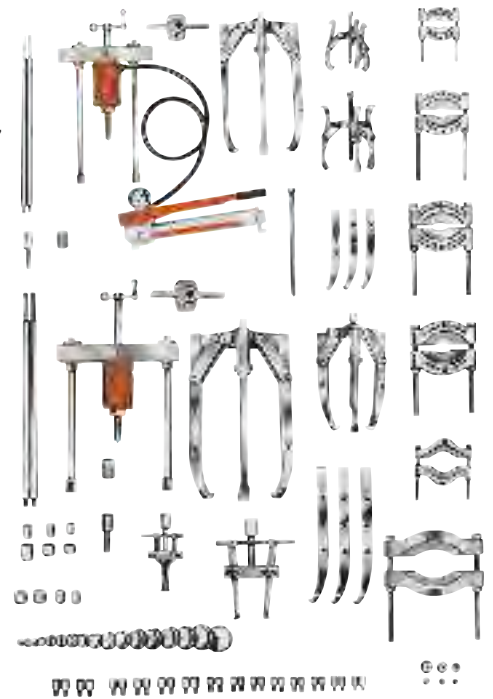

Order No.	Hydraulics	Order No.	Accessories
P55	Single-stage hyd. hand pump assembly	24832	Special puller forcing screw
RT172	17 1/2 ton center-hole twin cylinder w/ threaded insert	8075	Step plate adapter set
RT302	30 ton center-hole twin cylinder w/ threaded insert	8076	Step plate adapter set
9798	Hose half coupler	8056	Shaft protector set
9767	Hydraulic hose – 6'	679	Pulley pulling attachment
9670	Tee adapter	680	Pulley pulling attachment
9059	Pressure gauge	1154	Bearing cup pulling attach.
Pullers		1166	Bearing cup pulling attach.
1062	17 1/2 ton cap. hydraulic Push-Puller® w/ 16 1/2" legs	1122	Bearing pulling attachment
1070	30 ton cap. hydraulic Push-Puller® w/ 18" legs	1123	Bearing pulling attachment
1066	17 1/2 ton 3-jaw hyd. puller	1126	Bearing pulling attachment
1074	30 ton 3-jaw hyd. puller	1130	Bearing pulling attachment
41224	17 1/2 ton 2-jaw puller head	Threaded Adapters	
41226	30 ton 2-jaw puller head	8005	5/8" – 18 F. x 3/8" – 16 M. (2)
1027	Combination 2/3-jaw puller	8006	5/8" – 18 F. x 1/2" – 20 M. (2)
1037	Combination 2/3-jaw puller	8007	5/8" – 18 F. x 1/2" – 13 M. (2)
1041	Combination 2/3-jaw puller	8010	5/8" – 18 F. x 5/8" – 11 M. (2)
43892	Long jaws (3) for 1037	8012	1" – 14 F. x 5/8" – 18 M. (2)
30902	Long jaws (3) for 1041	8013	5/8" – 18 F. x 3/4" – 16 M. (2)
1105	22 1/2" legs for 1062	8015	5/8" – 18 F. x 3/4" – 10 M. (2)
1111	28" legs for 1070	8017	5/8" – 18 F. x 7/8" – 14 M. (2)
24814	Speed crank	8018	5/8" – 18 F. x 7/8" – 9 M. (2)
27198	Speed crank	8019	5/8" – 18 F. x 1" – 14 M. (2)
28229	Screw cap	8020	1" – 8 F. x 5/8" – 18 M. (1)
28228	Cylinder cap	8021	1" – 8 F. x 1" – 14 M. (1)
32118	Adjusting screw	8025	1 1/4" – 7 F. x 5/8" – 18 M. (2)
34758	Adjusting screw	8027	1 1/4" – 7 F. x 1" – 14 M. (2)
34510	Pushing adapter	8036	1" – 14 F. x 1" – 14 F. (2)
201923	Pushing adapter	8038	5/8" – 18 F. x 3/4" – 16 F. (2)
		8044	Female threaded adapter set

CAUTION: All the items shown may not withstand the full tonnage specified. Example: When an accessory with a 1 ton capacity is used with a 7 ton puller, the setup can be used only at a force of 1 ton.

IPS5017

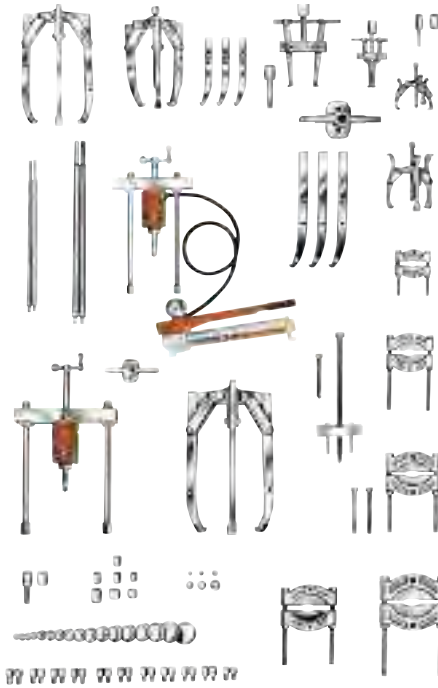

17½ and 50 ton capacity puller sets – If your looking for a maintenance puller set that will handle a wide variety of applications, this is the one for you. The mechanical and hydraulic pullers and attachments are designed to handle most removing and installing jobs with a minimal amount of effort.

No. IPS5017 – 17½ and 50 ton capacity manual and hydraulic puller set. Includes hydraulics, pullers, wooden storage box and accessories listed below. Wt., 892 lbs.

No. IPS5017B – Puller set with MB16 metal box. Wt., 915 lbs.

Order No.	Hydraulics	Order No.	Accessories
P55	Single-stage hyd. hand pump assembly	8075	Step plate adapter set
RT172	17½ ton center-hole twin cylinder w/ threaded insert	8076	Step plate adapter set
RT503	50 ton center-hole twin cylinder w/ threaded insert	8056	Shaft protector set
9798	Hose half coupler	1154	Bearing cup pulling attach.
9767	Hydraulic hose – 6'	1166	Bearing cup pulling attach.
9670	Tee adapter	1122	Bearing pulling attachment
9059	Pressure gauge	1123	Bearing pulling attachment
	Pullers	1126	Bearing pulling attachment
1062	17½ ton cap. hydraulic Push-Puller® w/ 16½" legs	1127	Bearing pulling attachment
1076	50 ton cap. hydraulic Push-Puller® w/ 24" legs	1130	Bearing pulling attachment
1066	17½ ton 3-jaw hyd. puller	34479	Reducing adapter for 1166
1080	50 ton 3-jaw hyd. puller	10215	Hex nut; ¾" – 16 (2)
41224	17½ ton 2-jaw puller head	24829	Short bolt
50449	50 ton 2-jaw puller head		Threaded Adapters
1027	Combination 2/3-jaw puller	8005	⅝" – 18 F. x ⅜" – 16 M. (2)
1037	Combination 2/3-jaw puller	8006	⅝" – 18 F. x ½" – 20 M. (2)
1041	Combination 2/3-jaw puller	8007	⅝" – 18 F. x ½" – 13 M. (2)
43892	Long jaws (3) for 1037	8010	⅝" – 18 F. x ⅝" – 11 M. (2)
30902	Long jaws (3) for 1041	8013	⅝" – 18 F. x ¾" – 16 M. (2)
1105	22½" legs for 1062	8015	⅝" – 18 F. x ¾" – 10 M. (2)
1113	34" legs for 1076	8019	⅝" – 18 F. x 1" – 14 M. (2)
24814	Speed crank	8020	1" – 8 F. x ⅝" – 18 M. (1)
29595	Speed crank	8021	1" – 8 F. x 1" – 14 M. (1)
28228	Screw cap	8023	1¼" – 12 F. x 1" – 14 M. (2)
28230	Cylinder cap	8028	1⅝" – 5½ F. x 1" – 8 M. (1)
32118	Adjusting screw	8029	1⅝" – 5½ F. x 1" – 14 M. (1)
32698	Adjusting screw	8038	⅝" – 18 F. x ¾" – 16 F. (1)
34755	Pushing adapter	8044	Female threaded adapter set
201923	Pushing adapter		
7392	Gear and pulley puller		
24833	Forcing screw for 7392		

CAUTION: All the items shown may not withstand the full tonnage specified. Example: When an accessory with a 1 ton capacity is used with a 7 ton puller, the setup can be used only at a force of 1 ton.



Note: Wooden storage box No. 3084360R9 is provided with this set. 45"L x 22½"H x 30"D
Metal storage boxes also available (see page 209).



Combination of 50 ton capacity Push-Puller and cup pulling attachment simplifies the removal of a final drive axle seal.



Hydraulically powered Push-Puller removes drive wheel. Pulling attachment is used to provide gripping surface.



3-jaw puller provides grip while hydraulic hand pump provides power to push shaft from housing. Shaft protector is used on end of puller screw.



PULLER SETS

Hydraulic

17¹/₂, 30 & 50 Ton

17¹/₂, 30 & 50 ton capacity puller set – Here's the ultimate in industrial puller sets! You'll find a puller for just about every job. Included in this "master set" are 17¹/₂, 30 and 50 ton hydraulics, along with an extensive assortment of pullers, attachments and adapters.

No. IPS5317 – 17¹/₂, 30 and 50 ton capacity manual and hydraulic puller set. Includes hydraulics, pullers, wooden storage box and accessories listed below. Wt., 1260 lbs.

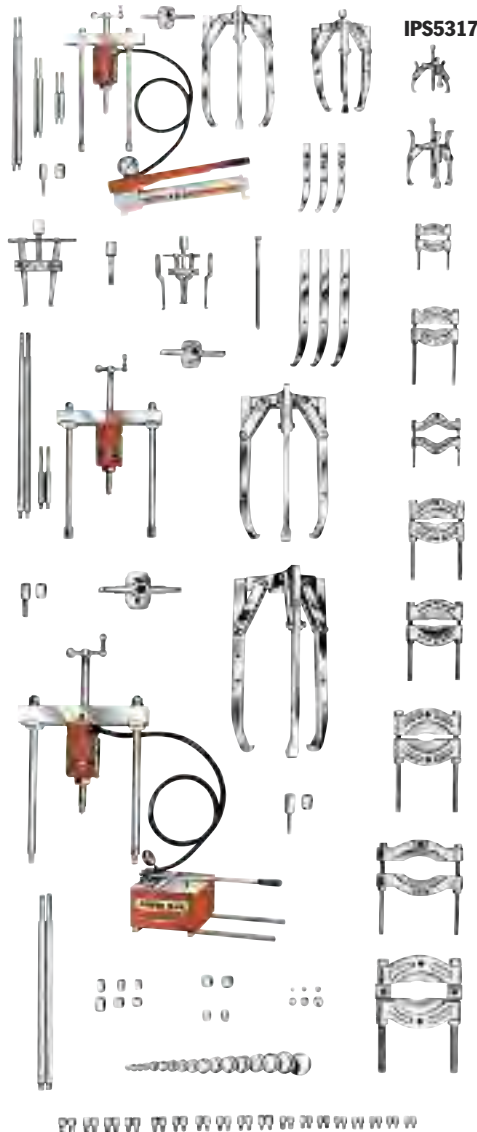

Note: Wooden storage box No. 3084400R9 is provided with this set. 46"L x 22¹/₂"H x 36"D Metal storage boxes also available (see page 209).

Set Contents	Hydraulics	Set Contents	Accessories
P55	Single-stage hyd. hand pump assembly	28230	Screw cap
P460	Two-stage hyd. hand pump w/ 3-way control valve	32118	Adjusting screw
RT172	17 ¹ / ₂ ton center-hole twin cylinder w/ threaded insert	32698	Adjusting screw
RT302	30 ton center-hole twin cylinder w/ threaded insert	34758	Adjusting screw
RT503	50 ton center-hole twin cylinder w/ threaded insert	34510	Pushing adapter
9798	Hose half coupler (2)	34755	Pushing adapter
9767	Hydraulic hose – 6' (2)	201923	Pushing adapter
9670	Tee adapter	8075	Step plate adapter set
9059	Pressure gauge	8076	Step plate adapter set
Pullers		8056	Shaft protector set
1062	17 ¹ / ₂ ton cap. hydraulic Push-Puller® w/ 16 ¹ / ₂ " legs	679	Pulley pulling attachment
1070	30 ton cap. hydraulic Push-Puller® w/ 18" legs	680	Pulley pulling attachment
1076	50 ton cap. hydraulic Push-Puller® w/ 24" legs	1154	Bearing cup pulling attach.
1066	17 ¹ / ₂ ton 3-jaw hyd. puller	1166	Bearing cup pulling attach.
1074	30 ton 3-jaw hyd. puller	1122	Bearing pulling attachment
1080	50 ton 3-jaw hyd. puller	1123	Bearing pulling attachment
41224	17 ¹ / ₂ ton 2-jaw puller head	1126	Bearing pulling attachment
41226	30 ton 2-jaw puller head	1127	Bearing pulling attachment
50449	50 ton 2-jaw puller head	1128	Bearing pulling attachment
1027	Combination 2/3-jaw puller	1130	Bearing pulling attachment
1037	Combination 2/3-jaw puller	34479	Reducing adapter
1041	Combination 2/3-jaw puller	Threaded Adapters	
43892	Long jaws (3) for 1037	8005	5/8" – 18 F. x 3/8" – 16 M. (2)
30902	Long jaws (3) for 1041	8006	5/8" – 18 F. x 1/2" – 20 M. (2)
32136	Long jaws (2) for 1154	8007	5/8" – 18 F. x 1/2" – 13 M. (2)
1105	22 ¹ / ₂ " legs for 1062	8010	5/8" – 18 F. x 5/8" – 11 M. (2)
1106	9 ¹ / ₂ " legs for 1062	8012	1" – 14 F. x 5/8" – 18 M. (2)
1107	4 ¹ / ₂ " legs for 1062	8013	5/8" – 18 F. x 3/4" – 16 M. (2)
1109	8" legs for 1070	8015	5/8" – 18 F. x 3/4" – 10 M. (2)
1111	28" legs for 1070	8017	5/8" – 18 F. x 7/8" – 14 M. (2)
1113	34" legs for 1070	8018	5/8" – 18 F. x 7/8" – 9 M. (2)
Accessories		8019	5/8" – 18 F. x 1" – 14 M. (2)
24832	Special puller forcing screw	8020	1" – 8 F. x 5/8" – 18 M. (1)
24814	Speed crank	8021	1" – 8 F. x 1" – 14 M. (1)
27198	Speed crank	8023	1 ¹ / ₄ " – 12 F. x 1" – 14 M. (2)
29595	Speed crank	8024	1 ¹ / ₄ " – 12 F. x 1 ³ / ₄ " – 12 M. (2)
28228	Screw cap	8025	1 ¹ / ₄ " – 7 F. x 5/8" – 18 M. (2)
28229	Screw cap	8027	1 ¹ / ₄ " – 7 F. x 1" – 14 M. (2)
		8028	1 ⁵ / ₈ " – 5 ¹ / ₂ F. x 1" – 8 M. (1)
		8029	1 ⁵ / ₈ " – 5 ¹ / ₂ F. x 1" – 14 M. (1)
		8036	1" – 14 F. x 1" – 14 F. (2)
		8038	5/8" – 18 F. x 3/4" – 16 F. (2)
		8044	Female threaded adapter set

CAUTION: All the items shown may not withstand the full tonnage specified. Example: When an accessory with a 1 ton capacity is used with a 7 ton puller, the setup can be used only at a force of 1 ton.

BEARING PUSHERS

8 Ton

These pushers are ideal for installing a wide variety of press-fit parts, including bushings, wheels, bearings, gears, and pulleys. Applications for the pushers will be found in motor repair shops, steel mills, mines, quarries, shipyards, utilities, maintenance shops, agricultural machinery repair, and the list goes on.

- Power Team, a leader in hydraulic tools for over 80 years, now adds patented, pushing systems to the world's most complete line of innovative equipment.
- Power Team pushers have been rigorously tested for top performance and reliability at maximum capacity.
- These pushing systems are covered by Power Team's exclusive Lifetime Marathon Warranty — assuring you of the highest quality and reliability.



PHP8H

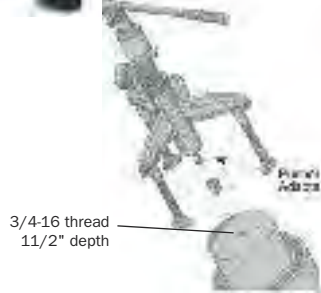

3/4-16 thread
1 1/2" depth



PHP8R

BEARING PUSHER KITS

- Portable pushing kits include an external Grip-O-Matic puller, an internal puller, hydraulic cylinder, and a tri-section pulling attachment, all in one compact, lightweight unit complete with carrying case.

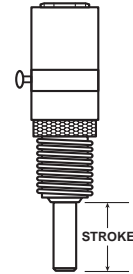
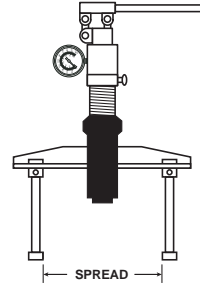
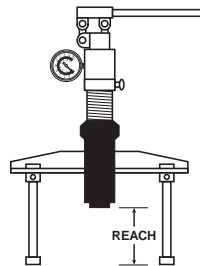

Order No.	Description	Cylinder Capacity	Reach in/mm	Spread in/mm	Stroke	Weight with Case lb/kg
PHP8H	Manual-Hydraulic Pusher	8 tons	2.16-15.16/ 55-385	2.28-10.62/ 58-270	3.23/82	74/33.5
PHP8R	Remote Hydraulic Pusher	8 tons	2.16-15.16/ 55-385	2.28-10.62/ 58-270	3.23/82	77.3/33
PHP8H-1	Manual-Hydraulic Pusher/Puller Kit	8 tons	2.16-15.16/ 55-385	2.28-10.62/ 58-270	3.23/82	117/53
PHP8R-1	Remote Hydraulic Pusher/Puller Kit	8 tons	2.16-15.16/ 55-385	2.28-10.62/ 58-270	3.23/82	114/52

IMPORTANT SAFETY INFORMATION: Power Team recommends the use of protective blankets for all pushing operations. For ease of visual clarity, we have shown the pusher application photos without these safeguards.



UNIVERSAL PULLERS

55 Ton & 100 TON



Note: Four cylinder extensions (not pictured) are included. The included lifting eyes (not pictured) permit use of an overhead crane to raise entire assembly.

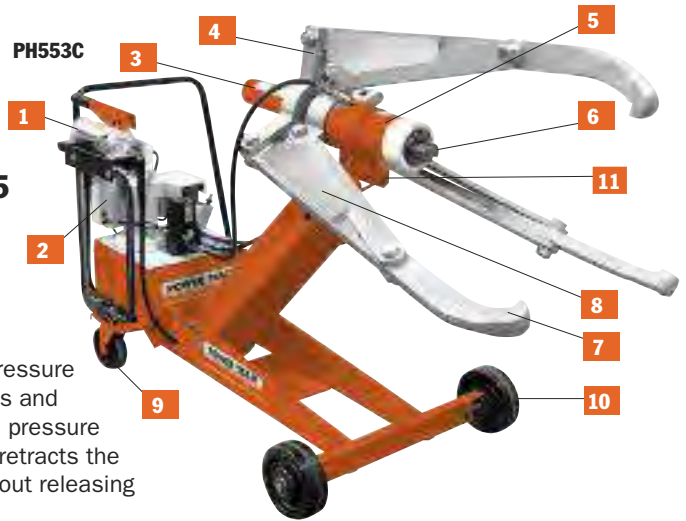

ENFORCER 55

- 1** Hydraulic lift system for easy, precise position of puller.
- 2** Unique dual pump arrangement: Low pressure pump positions, holds and opens jaws. The high pressure pump advances and retracts the pushing cylinder without releasing clamped jaws.
- 3** Hydraulically-actuated jaws. Cylinder moves in or out to provide a safe, secure grip on workpiece.
- 4** Puller can be assembled in 2 or 3 jaw configurations.
- 5** Choice of cylinder with a 6¹/₄" or 13¹/₄" stroke.
- 6** Self-centering: Center cylinder on work; puller jaws will automatically grip work evenly.
- 7** Super Grip-O-Matic® feature means the harder the pull, the tighter the puller jaws grip. No chains or cages required to keep puller jaws from slipping or springing off the part being pulled.
- 8** Guards at pinch points protect operator.
- 9** Cart's swivel casters give ease of mobility.
- 10** Large wheels make movement of cart easy.
- 11** Puller can be mounted on cart 90 degrees to right or left of puller cart centerline, permitting use in tight quarters, such as between machinery.

Conversion kit No. 251468 – Kit converts PH553C series to PH553CL series. Jaws are 12" longer. Kit contains three jaws and six straps with guards. Wt., 250 lbs.

Pushing Adapters

Order No.	A (in.)	B (in.)	Qty.*
251002	2 ³ / ₄	2 ³ / ₄	1
350593†	2 ³ / ₄	6	2
350594	2 ³ / ₄	3	1
350637	2 ³ / ₄	10	1

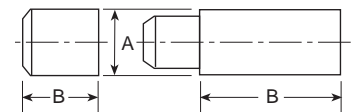

*Number of adapters supplied with each Enforcer.
†Only 1 for units with 13¹/₄" Stroke.

(251002)

Order No.	Min. Spread (in.)	Reach		Overall Length* (in.)	Cyl. Stroke (in.)	Power Source Requirements	Prod. Wt. (lbs.)	Puller Jaw Tip Dimensions		
		Min. Spread (in.)	Max. Spread (in.)					A (in.)	B (in.)	C (in.)
PH553C	4	22	48	14	90	6 ¹ / ₄	115 V, 60Hz, 25 Amp Cap.	7 ⁷ / ₈	1 ¹ / ₄	1 ⁷ / ₈
PH553C13	4	15	48	7	90	13 ³ / ₄	115V, 60Hz, 25 Amp Cap.			
PH553CL13	2 ¹ / ₂	25 ⁵ / ₈	45 ¹ / ₄	22	102	13 ³ / ₄	115V, 60Hz, 25 Amp Cap.			
PH553C-230	4	22	48	14	90	6 ¹ / ₄	230V, 50/60Hz, 15 Amp Cap.			
PH553C13-230	4	15	48	7	90	13 ³ / ₄	230V, 50/60Hz, 15 Amp Cap.			
PH553CL-230	2 ¹ / ₂	32 ⁵ / ₈	45 ¹ / ₄	29	102	6 ¹ / ₄	230V, 50/60Hz, 15 Amp Cap.			
PH553CL13-230	2 ¹ / ₂	25 ⁵ / ₈	45 ¹ / ₄	22	102	13 ³ / ₄	230V, 50/60Hz, 15 Amp Cap.			

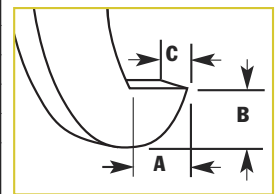

Note: See other pulling attachments on page 201

Note: Cart and Puller (cart width is 32")

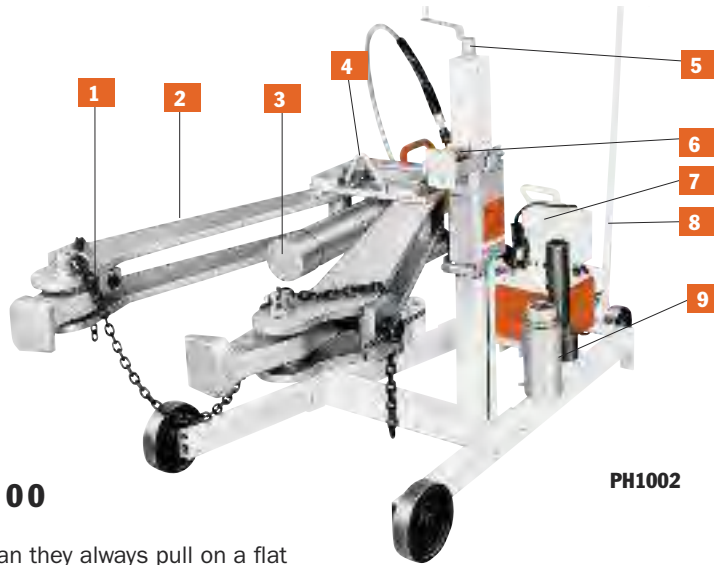

ENFORCER 100

PH1002

An ideal puller for steel mills, mines, oil fields, utility projects, paper mills, construction sites, railroads, airline shops, shipyards or anywhere else where large equipment and machinery pose tough maintenance challenges.

- 1 Adjustable jaws mean they always pull on a flat surface. Retaining chain holds jaws in place during positioning.
- 2 Grip-O-Matic® feature means jaws grip progressively tighter as more pulling force is applied.
- 3 100 ton hydraulic cylinder is single-acting, spring return type with a maximum working pressure of 10,000 psi.
- 4 Lifting bracket allows puller to be lifted if the workpiece center is more than 36" off the floor.
- 5 Adjusting screw allows operator to move vertical position of the puller.
- 6 Spring loaded feature means Enforcer 100 will align itself on uneven pulls.
- 7 Hydraulic pump is a 2-stage, high pressure unit controlled by remote hand switch with 25 foot cord.
- 8 Tow bar provides puller with plenty of mobility.
- 9 Pushing adapters have a diameter of 4¹/₈" and 2¹/₂".

"Enforcer 100" universal puller –

No. PH1002 – 100 ton, 2-jaw universal hydraulic puller. Includes: 2-jaw Grip-O-Matic® puller, PE552S 2-speed electric/hydraulic power unit, C10010C 100 ton hydraulic cylinder with 10¹/₄" stroke and six adapters. Wt., 890 lbs.

No. PH1002J – Same as PH1002, but without hydraulic power unit. Wt., 825 lbs.

PE552S – Pump only. 1¹/₈ hp, 115 volt, 50/60Hz, single phase, draws 25 amps at full load. Also available in 220 volt, 50Hz.

Note: For 220 volt, 50 Hz applications, order Part No. PH1002-220

Ram extensions

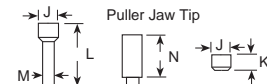

Order No.	Adapter Type	Amount included w/puller	J (in.)	K (in.)	L (in.)	M (in.)	N (in.)
44745	Push	1	4 ¹ / ₈	—	13 ¹ / ₂	2 ¹ / ₂	—
44766	Ext.	4	4 ¹ / ₈	—	—	—	8
303045	Push	1	4 ¹ / ₈	3 ¹ / ₂	—	—	—

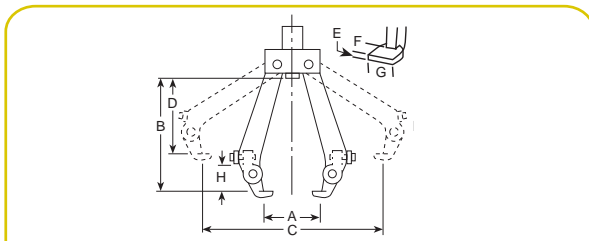

Order No.	Reach			Puller Jaw Tip	Cylinder Height	Vertical Stroke Adjust. (in.)	Overall Length (in.)	Max. Thickness Workpiece	Wheel Dia.	Power Source Requirements
	Min. Spread A (in.)	Min. Spread B (in.)	Max. Spread C (in.)							
PH1002	15	42	48	34	10 ¹ / ₄	12-36	94	12	8	115v, 50/60Hz, 25 Amp Cap.
PH1002J	15	42	48	34	10 ¹ / ₄	12-36	94	12	8	—



ROLLER BEARING PULLER/INSTALLER

(Railroad Edition)
100 Ton Pulling Capacity



Our roller bearing pullers are ideal for replacing tough, worn-out bearings on RR freight cars.



The photo above shows the Universal Puller in position on the roller bearing assembly, which is ready for removal.

- Quickly remove or install tapered roller bearings.
- Designed with cooperation of major bearing manufacturers.
- It's a fast, simple, one-man operation with 100-tons of pulling force provided.
- Completely portable for easy, convenient positioning and out-of-the-way storage.
- The standard in most wheel shops.

Universal railroad axle journal roller bearing puller/installer – For years, the standard in most wheel shops. Power Team now has four models to choose for greater flexibility. With both sling and jack models available and two pumps to choose from, you can tailor the unit to match your needs. With the proper equipment and know-how, removal and installation of axle journal roller bearings takes an absolute minimum of time and effort.

Each unit will service a full line of bearings with rotating end caps, from class B thru GG. No other method can match Power Team's simplicity. Removal is very easy. Simply remove the end caps, slip the pulling shoe between the bearings and the wheel, actuate the pump, and in seconds, 100 tons of pulling force removes the bearing. Installation is just as easy! Each unit is CSA certified (LR19814) and comes complete with a heavy-duty 100-ton hydraulic cylinder, 10,000 PS.I. (700 bar) pump with remote control solenoid valve, hydraulic pressure gauge (No. 11543), a pulling shoe and installing tube.

Order No.	Model Type	Cylinder Type	Valve Type	Pump Information		
				H.P	Phase	Voltage
PR2100J	† Jack	Double Acting	Solenoid	2**	1	115 or 230*
PR3100J	† Jack	Double Acting	Solenoid	3	3	230 or 460*
PR2100S	† Sling	Double Acting	Solenoid	2	1	115 or 230*
PR3100S	† Sling	Double Acting	Solenoid	3	3	230 or 460*

* Prewired at factory for this voltage. Other voltages available upon request.

** The 2 H.P., 115 volt requires 30 amp service.

Tooling order information - IMPORTANT...This tooling chart applies only to standard AAR configurations for freight care applications. In order to provide adapters needed to service housing-type locomotive and passenger car bearings, as well as metric bearings, Power Team must be provided with the following information: bearing manufacturer's name and general arrangement drawing number, size of bearing to be serviced, railroad name and location and part numbers of adapters already in your possession if you currently own a Puller/Installer.

Tool Description	Class and size of bearing assembly			
	TBU & SP "Metric Tooling"			
	120	130	140	150
Pulling Shoe Insert Adapter	No. 351830	No. 30512	No. 30521	No. 30520
Guide Tube & Cap Screw Assembly	No. 253341	No. 253342	No. 253343	No. 253344
Cap Screw**	No. 253339	No. 253394	No. 253339	No. 253395
Guide Tube Adapter	No. 21247	No. 21247	No. 21247	No. 21247
Installing Tube Adapter Ring	No. 253335	No. 253336	No. 253337	No. 253338

** Screws are supplied with the guide tube and should be ordered as replacements only.





PR3100J



PR3100S

Tool Description	Class and size of bearing assembly to be serviced									
	Class B 4 7/8" x 8" (No.)	Class C 5" x 9" (No.)	Class D 5 1/2" x 10" (No.)	Class E 6" x 11" (No.)	Class EE 5 1/2" Axle (No.)	Class EE 6" Axle (No.)	Class F 6 1/2" x 12" (No.)	Class G 7" x 12" (No.)	Class G 6 1/2" Axle (No.)	Class GG 6 1/2" Axle (No.)
Pulling Shoe	No. 420845 is included as part of basic machine – Do Not Order							420846	420846	420846
Pulling Shoe	30522	30512	30521	30520	30520	30519	30519	—	—	—
Insert Adapter										
Guide Tube & Cap Screw Assembly	253313	253314	253317	253318	253316	253327	253320	253321	253319	253323
Cap Screw**	253156	253349	253308	253155	253307	253308	253310	253326	253309	253309
Guide TubeNo. Adapter	23934	21248	21248	21247	21247	21247	21247	21247	21247	21247
Installing Tube	No. 30416 is included as part of basic machine – Do Not Order							30417	30417	30417
Installing Tube Adapter Ring	21242	21258	21256-1	21255-1	21255-1	21257-1	21257-1	30586	30585	30585

Note: Adapters listed above are for servicing the following roller bearing assemblies: Brenco "Crown-Taper", New Departure-Hyatt "Hy-Roll Taper", SKF "Expediter" and Timken "AP".

** Screws are supplied with the guide tube and should be ordered as replacements only.

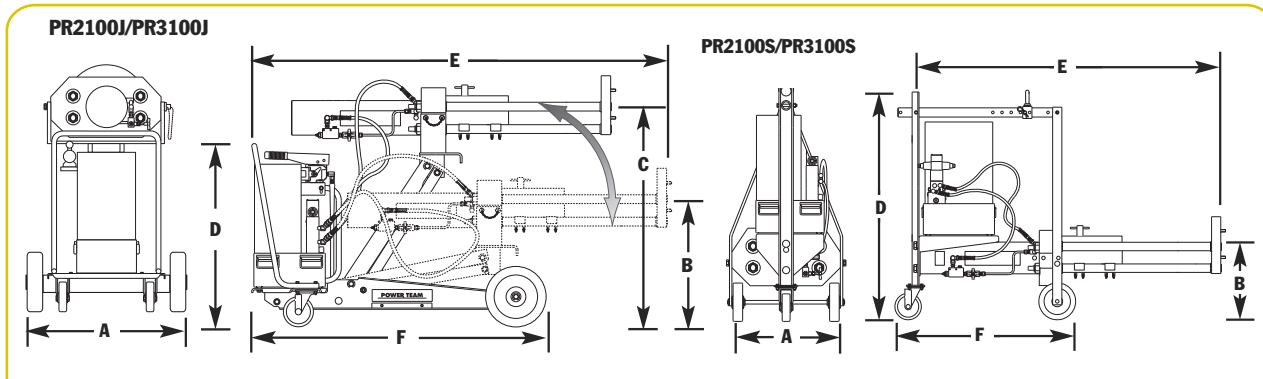

Order No.	Stroke (in.)	Capacity			Speed			A (in.)	B (in.)	C (in.)	D (in.)	E (in.)	F (in.)	Weight (lbs.)
		Pull (Tons)	Inst. (Tons)	Advance (in./min.)	Pull (in./min.)	Inst. (in./min.)								
PR2100J	15 1/2	100	68	35 7/16	3 3/16	4 7/16	32	15 1/16	41 11/16	36 29/32	78	58 3/4	1,162	
PR3100J	15 1/2	100	68	35 7/16	3 3/16	4 7/16	32	15 1/16	41 11/16	36 29/32	78	58 3/4	1,146	
PR2100S	15 1/2	100	68	35 7/16	3 3/16	4 7/16	24 3/8	11	—	50 1/2	64 1/4	38 3/4	1,003	
PR3100S	15 1/2	100	68	35 7/16	3 3/16	4 7/16	24 3/8	11	—	50 1/2	64 1/4	38 3/4	1,008	



DRIVERS

Bearing, Bushing And Seal



**No. 27793
Starter Set**



7180

**27797 Master Set
(Board not included)**

Patent No. 4,429,447

Universal bearing cup installer

This installer adjusts to fit bearing cups from 3⁵/₈" to 6¹/₂" O.D. Replaces over two dozen plates and drivers. Simply adjust the jaws to fit the cup I.D., lock the jaws, slip the new cup on and drive it home with a hammer. Will not damage new bearings.

No. 7180 – Univ. bearing cup installer. Wt., 10 lbs.

Assemble your own "custom-made" driver tools

These sets include discs and handles for custom seal driver assembly to provide a pilot (to prevent cocking), a spacer (so force is applied on the proper area) and a driver (for even force dist.). Discs range

from 1/2" thru 4 1/2" diameters in 1/16" increments. Each set includes a handy plastic box with pre-cut tool tray.

No. 27793 – Starter Set. Contains handle and discs especially selected to provide the driver sizes most frequently needed. Maximum utility at a modest investment! Wt., 4 lbs.

No. 27794 – Basic Set. Wide coverage, low investment! Includes 41 discs and two handles. Size range: 1/2" thru 3" diameter. Wt., 22 lbs.

No. 27795 – Big Job Set. Used for servicing large components. You get coverage of 3 1/16" thru 4 1/2" diameter with the 24 discs and handle provided. Wt., 45 lbs.

No. 27797 – Master Set. For maximum coverage. Three handle sizes and all 65

discs listed in chart at left are included. Range: 1/2" thru 4 1/2" diameter. Wt., 68 lbs.

No. 212377 – Tool organizer board. Will accommodate all components of 27797 Master Set. Tools not included. Wt., 5 lbs.

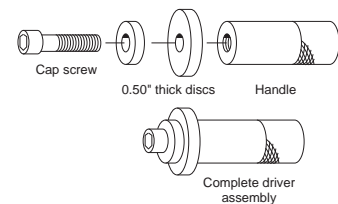

These sets have the proper-size driver for any seal, bearing or bushing installing job. Select the proper-size discs, attach to handle with cap screws and strike with hammer.

Order No.	DISCS Inch	MM	Order No.	DISCS Inch	MM	Order No.	DISCS Inch	MM
27492	9/16	14.3	27513†	1 7/8	47.6	27535	3 1/4	82.6
27493†	5/8	15.9	27514	1 15/16	49.2	27536	3 5/16	84.1
27494	1 1/16	17.5	27515	2	50.8	27537	3 3/8	85.7
27495†	3/4	19.0	27516	2 1/16	52.4	27538	3 7/16	87.3
27496	13/16	20.6	27517	2 1/8	54.0	27539	3 1/2	88.9
27497†	7/8	22.2	27518	2 3/16	55.6	27540	3 9/16	90.5
27498	15/16	23.8	27519	2 1/4	57.2	27541	3 5/8	92.1
27499†	1	25.4	27520	2 5/16	58.7	27542	3 11/16	93.7
27500	1 1/16	27.0	27521	2 3/8	60.3	27543	3 3/4	95.3
27501†	1 1/8	28.6	27522	2 7/16	61.9	27544	3 13/16	96.8
27502	1 3/16	30.2	27523	2 1/2	63.5	27545	3 7/8	98.4
27503†	1 1/4	31.8	27524	2 9/16	65.1	27546	3 15/16	100.0
27504	1 5/16	33.3	27525	2 5/8	66.7	27547	4	101.6
27505†	1 3/8	34.9	27526	2 11/16	68.3	27548	4 1/16	103.2
27506	1 7/16	36.5	27527	2 3/4	69.8	27549	4 1/8	104.8
27507†	1 1/2	38.1	27528	2 13/16	71.4	27550	4 3/16	106.4
27508	1 9/16	39.7	27529	2 7/8	73.0	27551	4 1/4	108.0
27509†	1 5/8	41.3	27530	2 15/16	74.6	27552	4 5/16	109.5
27510	1 11/16	42.9	27531	3	76.2	27553	4 3/8	111.1
27511†	1 3/4	44.4	27532	3 1/16	77.8	27554	4 7/16	112.7
			27533	3 1/8	79.4	27555	4 1/2	114.3

† = Items contained in 27793 starter set.

SET COMPONENTS

Order No. Description

10012†	1/4"-20 UNC X 7/8"*
10020†	1/4"-20 UNC X 1 1/4"*
10854†	1/4"-20 UNC X 1 3/4"*
10855†	1/4"-20 UNC X 2 3/4"*
12001†	1/4"-20 UNC X 2 1/4"*
27487†	Small Handle 5" X 3/4" Dia.
27488	Med. Handle 6" X 1 1/4" Dia.
27489	Large Handle 6" X 1 5/8" Dia.
27490	Extension Tube
7350†	Allen Wrench



SELECTING A PUNCH

The following information is provided as a convenient general reference guide for metal punching operations.

HOLE SIZE VS. MATERIAL THICKNESS

Punching holes in metal is the fast, economical way to get precise hole size, smoothness and minimum burr. Compressive strength of the punch steel determines that the thickness of the metal being punched must not exceed the diameter of the punch. This relationship varies with the type of material. For example: the minimum hole diameter will be 1/4" in 1/4" mild steel, 1/4" in 3/16" stainless steel, and 1/4" in 5/16" aluminum.

MAXIMUM RATED CAPACITY

All punching tools have their maximum capacity for safe, dependable operation over a long life span. The hydraulic punches listed in this catalog have a "rated capacity" based on their design strength. Before selecting a tool, use the following charts to determine the specific tonnage required to punch the size and shape holes through the type and gauge metal considered.

DETERMINING TONNAGES FOR ROUND HOLES

To determine tonnages for hot rolled mild steel (typically used in bar size angle iron, channels, tees and zees) with a 50,000 PSI shear strength, read directly from chart #1. Example: To punch a 3/8" diameter hole thru 3/8" thick mild steel, chart #1 shows 11.1 tons are required.

For ASTM A-36 steel (typically used for structural size wide flange, H and I beams, tees and zees) with a 60,000 PSI shear strength, read direct from chart #2. Example: To punch a 1/4" round hole in 1/4" thick A-36 steel, chart #2 shows 5.9 tons of force is needed.

CHART #1		TONS OF PRESSURE REQUIRED TO PUNCH MILD STEEL												TONS OF PRESSURE
Material		Round Hole Diameter												
Thickness		1/8"	3/16"	1/4"	5/16"	3/8"	7/16"	1/2"	9/16"	5/8"	11/16"	3/4"	13/16"	
Gauge	Inches													
20	1/32	.4	.5	.7	.9	1.1	1.2	1.4	1.6	1.8	1.9	2.1	2.3	
18	3/64	.5	.7	.9	1.2	1.4	1.6	1.9	2.1	2.4	2.6	2.8	3.1	
16	1/16	.6	.9	.6	1.5	1.8	2.1	2.3	2.6	2.9	3.2	3.5	3.8	
14	5/64	.7	1.1	1.2	1.8	2.2	2.6	2.9	3.3	3.7	4.0	4.4	4.8	
12	7/64	1.0	1.5	1.5	2.6	3.1	3.6	4.1	4.6	5.1	5.7	6.2	6.7	
11	1/8	1.2	1.8	2.1	2.9	3.5	4.1	4.7	5.1	5.9	6.2	7.1	7.6	
10	9/64	1.3	2.0	2.4	3.3	4.0	4.6	5.3	5.9	6.6	7.3	7.9	8.6	
3/16"	3/16	—	2.8	2.6	4.6	5.5	6.4	7.4	8.3	9.2	10.1	11.0	12.0	
1/4"	1/4	—	—	3.7	6.1	7.4	8.6	9.8	11.1	12.3	13.5	14.7	16.0	
5/16"	5/16	—	—	4.9	7.8	9.2	10.7	12.3	13.9	15.4	17.0	18.5	20.0	
3/8"	3/8	—	—	—	—	11.1	12.8	14.8	16.5	18.5	20.2	22.1	23.8	
1/2"	1/2	—	—	—	—	—	—	19.7	22.0	24.6	26.9	29.5	31.8	

CHART #2		TONS OF PRESSURE REQUIRED TO PUNCH ASTM-A36 STRUCTURAL STEEL												TONS OF PRESSURE
Material		Round Hole Diameter												
Thickness		1/8"	3/16"	1/4"	5/16"	3/8"	7/16"	1/2"	9/16"	5/8"	11/16"	3/4"	13/16"	
Gauge	Inches													
12	7/64	1.2	1.9	2.5	3.1	3.7	4.3	4.9	5.6	6.2	6.8	7.4	8.0	
11	1/8	1.4	2.1	2.8	3.5	4.2	4.9	5.7	6.4	7.1	7.8	8.5	9.2	
10	9/64	—	2.4	3.2	4.0	4.8	5.6	6.4	7.2	7.9	8.7	9.5	10.3	
3/16"	3/16	—	3.3	4.4	5.5	6.6	7.7	8.8	9.9	11.0	12.1	13.2	14.3	
1/4"	1/4	—	4.4	5.9	7.4	8.6	10.3	11.8	13.2	14.7	16.2	17.7	19.1	
5/16"	5/16	—	—	7.4	9.2	11.0	12.9	14.7	16.5	18.4	20.2	22.0	24.0	
3/8"	3/8	—	—	8.8	11.0	13.3	15.5	17.7	19.9	22.1	24.3	26.5	28.7	
1/2"	1/2	—	—	—	—	—	—	23.6	26.5	29.4	32.4	35.3	38.3	

MEASUREMENTS/ SPECIFICATIONS

Die Clearance

CHART #3 TONS OF PRESSURE REQUIRED TO SHEAR 1" LENGTH

Material Thickness	Mild Steel	Stainless Steel	Brass	TONS OF PRESSURE
3/16	4.25	7.0	3.25	
1/4	6.25	9.5	4.5	
5/16	8.0	12.0	5.5	
3/8	9.5	14.25	6.25	
7/16	11.0	16.5	7.75	
1/2	12.5	18.75	8.75	

DETERMINING TONNAGES FOR IRREGULAR SHAPED HOLES

When punching irregular shaped holes (square, obround, etc...) multiply the length of metal to be cut by the multiplier given for a 1" length of cut in chart #3. Example: The shear length (or total dis-

tance around a 1/2" square hole) is 2". To punch such a hole in 1/4" thick mild steel, multiply 2" x 6.25 (from chart #3) = 12.5 tons. For stainless steel this would be 2" x 9.5 = 19 tons.

DIE CLEARANCE

The relationship of the larger die hole size to the punch size is die clearance and is stated as a percentage of the thickness of the material being punched. The range of clearances varies from 10% for thin materials to 20% for thicker materials. For 0.75" material, the total die clearance is .150".



Clearance should always be specified when there is any reason for doubt (see illustrations below). Effects of die clearance are more noticeable in thicker materials (such as 0.50") than in thinner materials (such as 0.19"). When ordering die sets, specify the type and thickness of material being punched (see chart #4).

CHART #4 CLEARANCE FOR MILD STEEL

Material Thickness	Approximate Decimal Thickness	Overall Clearance-Add to Punch Size	TONS OF PRESSURE
7 gauge	.1793	.021	
3/16	.1875	.023	
1/4	.250	.037	
5/16	.3125	.047	
3/8	.375	.057	
1/2	.500	.075	

NOTE: Most grades of half hard aluminum use the same clearance as shown above. In many cases, your own experience may dictate that you call for clearances different from the above, especially when punching other materials such as stainless steel. Special clearances may be ordered for that purpose.

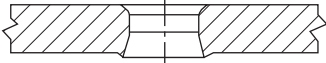
DIE CLEARANCE HAS THE FOLLOWING EFFECTS:

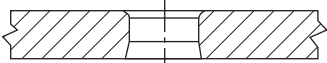
Too much clearance	Too little clearance	Correct Clearance
		
<ol style="list-style-type: none"> 1. Extra roll-in at top of the hole. 2. Too much burr at bottom of the hole. 	<ol style="list-style-type: none"> 1. More punching pressure needed. Can reduce tool life. 2. High stripping force causes part distortion and extra punch wear. 	<ol style="list-style-type: none"> 1. Straighter hole thru material. 2. Minimum distortion at top of hole. 3. Minimum burr at bottom of hole.

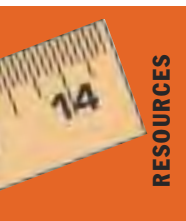

USE THE 50, 75 OR 200 GPM TESTER TO SIMULATE ACTUAL OPERATING CONDITIONS OF THE SYSTEM UNDER TEST

Testing the pump: Operator runs engine at a specific rpm and adjusts tester's pressure compensating valve to simulate a work load. By comparing meter readings with manufacturer specs, proper operation of pump can be confirmed. If oil flow and pressure do not meet specs, the pump is faulty. Or, if test results and specifications agree, the operator will know that the problem is elsewhere in the system and that other tests must be performed. Regardless of the component being tested, hook-up and testing is accomplished in minutes. NOTE: These hydraulic testers should always be used with the owner's manual/ manufacturers' specifications for the system under test.

Cyl. Caps furnished with "C" Series Cylinders:

5 ton cylinders	No. 201375
10 ton cylinders	No. 201362
15 ton cylinders	No. 201362
25 ton cylinders	No. 201412
55 ton cylinders	No. 36161
75 ton cylinders	No. 36161
100 ton cylinders	No. 36161

PERFORMANCE

The table at right gives you an idea of what to expect when coupling RD series cylinders to a Power Team pump. Actual performance will vary according to job conditions.

Pump	Cylinder	Time to Extend Cylinder 1"	
		100 psi	10,000 psi
PE55	RD55	1.0 sec.	12.0 sec.
	RD100	1.8 sec.	22.5 sec.
	RD200	3.5 sec.	45.0 sec.
	RD400	7.2 sec.	85.0 sec.
PQ120 Series	RD200	3.4 sec.	20.6 sec.
	RD300	4.9 sec.	30.0 sec.
	RD400	6.4 sec.	39.0 sec.
PE400 Series	RD300	3.0 sec.	8.5 sec.
	RD400	3.9 sec.	11.1 sec.
	RD500	4.9 sec.	14.1 sec.

NOTE: Base mounting holes are standard on all RD cylinders. Orientation of base mounting holes to coupler. Orientation on RD300, RD400 & RD500 series is random.

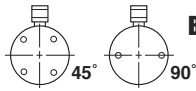

BASE MOUNTING HOLES FOR "RD" CYLINDERS

Tonnage	10	25	55	80	100	150	200	300	400	500
No. of Holes	2	4	4	4	4	4	4	4	4	6
Thread Size	3/8"-16	1/2"-13	5/8"-11	5/8"-11	3/4"-10	1"-8	1 1/4"-7	1 1/4"-7	1 1/2"-12	1 3/8"-12
Depth	5/8"	3/4"	7/8"	7/8"	1"	1"	1 1/4"	1 3/4"	1 7/8"	2"
B.C. Dia.	2"	2 3/4"	3 1/2"	4 1/2"	5 1/2"	6"	6 1/2"	6 1/4"	7 1/4"	8"
Orientation	90°	45°	45°	45°	45°	45°	45°	Random	Random	Random

MOUNTING HOLES FOR "RLS" CYLINDERS

RLS50	1 1/32" C'bore x 1/4" deep, 7/32" thru hole	RLS200	39/64" C'bore x 13/32" deep, 13/32" thru hole	RLS500S	45/64" C'bore x 1/2" deep, 15/32" thru hole	RLS1000S	51/64" C'bore x 9/16" deep, 17/32" thru hole
RLS100	27/64" C'bore x 11/32" deep, 9/32" thru hole	RLS300	39/64" C'bore x 7/16" deep, 13/32" thru hole	RLS750S	51/64" C'bore x 9/16" deep, 17/32" thru hole	RLS1500S	13/16" C'bore x 9/16" deep, 17/32" thru hole

POST TENSION/STRESSING JACK DIMENSIONS

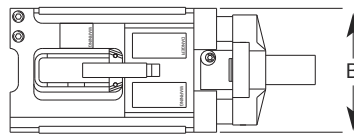
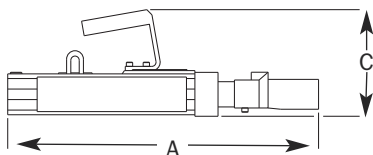

Order Number	A (in.)	B (in.)	C (in.)	Weight (lbs.)
SJ2010	21	9	6 1/2	55
SJ2010	22	10 13/64	7	76
SJ3010	22	10 13/64	7	76
SJ3010P	22	10 13/64	7	76
SJ2010DA	18 1/2	7 1/2	6 1/2	42
SJ3010DA	18 1/2	8 1/2	6 1/2	52

MEASUREMENTS/ SPECIFICATIONS

Conversion Formulas

	DECIMALS	MILLIMETERS
1/64	.015625	— 0.397
1/32	.03125	— 0.794
3/64	.046875	— 1.191
1/16	.0625	— 1.588
5/64	.078125	— 1.984
3/32	.09375	— 2.381
7/64	.109375	— 2.778
1/8	.1250	— 3.175
9/64	.140625	— 3.572
5/32	.15625	— 3.969
11/64	.171875	— 4.366
3/16	.1875	— 4.763
13/64	.203125	— 5.159
7/32	.21875	— 5.556
15/64	.234375	— 5.953
1/4	.2500	— 6.350

DECIMAL & MILLIMETER EQUIVALENTS

17/64	.265625	— 6.747	21/32	.65625	— 16.669
9/32	.28125	— 7.144	43/64	.671875	— 17.066
19/64	.296875	— 7.541	11/16	.6875	— 17.463
5/16	.3125	— 7.938		DECIMALS	MILLIMETERS
21/64	.328125	— 8.334	45/64	.703125	— 17.859
11/32	.34375	— 8.731	23/32	.71875	— 18.256
	DECIMALS	MILLIMETERS	47/64	.734375	— 18.653
23/64	.359375	— 9.128	3/4	.7500	— 19.050
3/8	.3750	— 9.525	49/64	.765625	— 19.447
25/64	.390625	— 9.922	25/32	.78125	— 19.844
13/32	.40625	— 10.319	51/64	.796875	— 20.241
27/64	.421875	— 10.716	13/16	.8125	— 20.638
7/16	.4375	— 11.113	53/64	.828125	— 21.034
29/64	.453125	— 11.509	27/32	.84375	— 21.431
15/32	.46875	— 11.906	55/64	.859375	— 21.828
31/64	.484375	— 12.303	7/8	.8750	— 22.225
1/2	.5000	— 12.700	57/64	.890625	— 22.622
33/64	.515625	— 13.097	29/32	.90625	— 23.019
17/32	.53125	— 13.494	59/64	.921875	— 23.416
35/64	.546875	— 13.891	15/16	.9375	— 23.813
9/16	.5625	— 14.288	61/64	.953125	— 24.209
37/64	.578125	— 14.684	31/32	.96875	— 24.606
19/32	.59375	— 15.081	63/64	.984375	— 25.003
39/64	.609375	— 15.478	1	1.000	— 25.400
5/8	.6250	— 15.875			
41/64	.640625	— 16.272			

1 mm = .03937"
.001" = .0254 mm

SI* CONVERSION FORMULAS

APPROXIMATE CONVERSION

MULTIPLY	BY	TO GET OR MULTIPLY	BY	TO GET
SI* UNIT	CONV FACTOR	NON-SI UNIT	CONV FACTOR	SI* UNIT
LENGTH				
millimeter (mm)	X 0.03937	= inch	X 25.4	= mm
(1 inch = 25.4 mm exactly)				
centimeter (cm)	X 0.3937	= inch	X 2.54	= cm
meter (m)	X 3.28	= foot	X 0.305	= m
meter (m)	X 1.09	= yard	X 0.914	= m
kilometer (km)	X 0.62	= mile	X 1.61	= km
AREA				
millimeter ² (mm ²)	X 0.00155	= inch ²	X 645	= mm ²
centimeter ² (cm ²)	X 0.155	= inch ²	X 6.45	= cm ²
meter ² (m ²)	X 10.8	= foot ²	X 0.0929	= m ²
meter ² (m ²)	X 1.2	= yard ²	X 0.836	= m ²
hectare (ha)	X 2.47	= acre	X 0.405	= ha
kilometer ² (km ²)	X 0.39	= mile ²	X 2.59	= km ²
VOLUME				
centimeter ³ (cm ³)	X 0.061	= inch ³	X 16.4	= cm ³
liter (l)	X 61	= inch ³	X 0.016	= l
milliliter (ml)	X 0.034	= oz-liq	X 29.6	= ml (1 ml = 1 cm ³)
liter (l)	X 1.06	= quart	X 0.946	= l
liter (l)	X 0.26	= gallon	X 3.79	= l
meter ³ (m ³)	X 1.3	= yard ³	X 0.76	= m ³
MASS				
gram (g)	X 0.035	= ounce	X 28.3	= g
kilogram (kg)	X 2.2	= pound	X 0.454	= kg
metric ton (t)	X 1.1	= ton (short)	X 0.907	= t

APPROXIMATE CONVERSION

MULTIPLY	BY	TO GET OR MULTIPLY	BY	TO GET
SI* UNIT	CONV FACTOR	NON-SI UNIT	CONV FACTOR	SI* UNIT
FORCE (N = kg • m/s²)				
newton (N)	X 0.225	= pound	X 4.45	= N
kilonewton (kN)	X 225	= pound	X 0.00445	= kN
TORQUE				
newton meter (N•m)	X 8.9	= lb. in.	X 0.113	= N•m
newton meter (N•m)	X 0.74	= lb. ft.	X 1.36	= N•m
PRESSURE (Pa = N/m²)				
kilopascal (kPa)	X 4.0	= in. H ₂ O	X 0.249	= kPa
kilopascal (kPa)	X 0.30	= in. Hg	X 3.38	= kPa
kilopascal (kPa)	X 0.145	= p.s.i.	X 6.89	= kPa
megapascal (MPa)	X 145	= p.s.i.	X 0.00689	= MPa
Bar	X 14.5	= p.s.i.	X .0689	= Bar
POWER (w = J/s)				
kilowatt (kw)	X 1.34	= hp	X 0.746	= kw
kilowatt (kw)	X 0.948	= Btu/s	X 1.055	= kw
watt (w)	X 0.74	= ft. lb/s	X 1.36	= w
TEMPERATURE				
°C = (°F - 32) ÷ 1.8		°F = (°C X 1.8) + 32		
FLOW				
cu. cm./min.	X .061	= cu. in./min.	X 16.4	= cu. cm./min.
liters/min.	X .2642	= GPM	X 3.785	= liters/min.

* System International (Modern Metric System)



Power Team's commitment to quality is evident in everything we do, from raw material receipt to how we support our customers years after they purchase our products. Power Team is registered to ISO 9001:2000 international quality standard. ISO 9001:2000 requires compliance with standards for management, administration, product development, manufacturing and continual improvement. Our

Registration verifies that Power Team has adopted and maintains documentation for processes ranging from suppliers to customers, inspection, handling, and training. ISO 9001 also requires periodic internal and external audits to ensure all aspects of work affecting quality control are monitored. This always has been, and will continue to be, our philosophy. That's our guarantee to you.

ASME B30.1

Power Team hydraulic cylinders fully comply with the criteria set forth in the American Society of Mechanical Engineers standard ASME B30.1:

1. Our cylinders are designed to have a minimum of a 2-to-1 safety factor on typical material yield strength;

Each cylinder is tested at 125 percent of rated pressure at full travel and is inspected to assure functionality and freedom from leaks.

ASME B40.1

Power Team heavy-duty pressure gauges are designed in accordance with the recommendations set forth in the American Society of Mechanical Engineers standard ASME B40.1, Grade B.

CE MARK

Power Team is committed to designing, manufacturing, and marketing products that meet or exceed the needs of the customers we serve. Power Team supplies a Letter of Incorporation or a Declaration of Conformity and CE Marking for products that conform with European community directives.

IJ100

Power Team hoses meet the criteria set forth in the Material Handling Institute's specification #IJ100 for hydraulic hose. Under the procedures outlined in this standard, hydraulic hose shall:

1. Have an average minimum life of 30,000 cycles at full rated capacity.
2. Have a minimum burst pressure of at least twice the rated operating pressure.



Where specified, Power Team electric power pump assemblies meet the design, assembly, and test requirements of the Canadian Standards Association. Note: If CSA certification is required, it must be requested at the time the pump is ordered.

NEMA

Where specified, Power Team electric power pump assemblies meet the design, assembly, and test requirements of NEMA 12, a National Electrical Manufacturers' Association standard relating to electrical components used to resist moisture and dust.

POWER TEAM PRODUCT DESIGN CRITERIA

All Power Team brand hydraulic components are designed and/or tested to be safe for use at maximum operating pressures of 10,000 psi unless otherwise specifically noted.

QUALITY ASSURANCE

All of our hydraulic cylinders are subjected to quality checks during production. All steel bar is certified and has material traceability to the mill. Before leaving the factory, all cylinders are pressure tested to 12,500 psi, except the RT series which are tested to 10,000 psi to insure on-the-job reliability. We have made every effort to include the latest specifications for our products in this catalog. Please call the Power Team factory for the most current product specifications. The Power Team Lifetime Marathon Warranty is described in more detail on pgs. 233 of this catalog.

MEASUREMENTS / SPECIFICATIONS

Torque Wrench Selection Guide

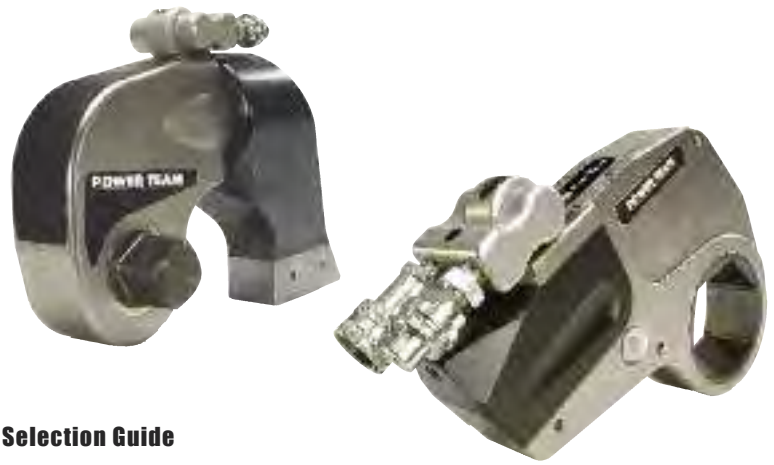

Torque Wrench Selection Guide

TOOL GUIDELINE

BOLT - TORQUE				RECOMMENDED MODEL					
SAE1 SAE 2 30,000 PSI	ASTM 193 B7 BOLT	8-7 A/F HEAVY HEX NUT	ASTM 354 B8 60000 PSI	FT. LBS.	Nm	SQUARE DRIVE MAKE-UP ONLY	LOW CLEARANCE MAKE-UP	SQUARE DRIVE Break Out	LOW CLEARANCE Break Out
1"	7/8"	1-7/16"		300	408	TWSD1	TWLC2	TWSD1	TWLC2
1-1/8"	1"	1-5/8"	7/8"	425	578	TWSD1	TWLC2	TWSD1	TWLC2
				500	680	TWSD1	TWLC2	TWSD1	TWLC2
1-1/4"			1"	600	816	TWSD1	TWLC2	TWSD1	TWLC2
1-3/8"	1-1/8"	1-13/16"		700	952	TWSD1	TWLC2	TWSD1	TWLC2
	1-1/4"	2"	1-1/8"	800	1,088	TWSD1	TWLC2	TWSD3	TWLC4
1-1/2"				900	1,224	TWSD1	TWLC2	TWSD3	TWLC4
				1,000	1,360	TWSD1	TWLC2	TWSD3	TWLC4
1-5/8"	1-3/8"	2-3/16"	1-1/4"	1,250	1,700	TWSD1	TWLC2	TWSD3	TWLC4
				1,350	1,836	TWSD1	TWLC2	TWSD3	TWLC4
	1-1/2"	2-3/8"	1-3/8"	1,500	2,040	TWSD3	TWLC2	TWSD3	TWLC4
1-3/4"				1,600	2,176	TWSD3	TWLC4	TWSD6	TWLC4
1-7/8"				1,800	2,448	TWSD3	TWLC4	TWSD6	TWLC4
	1-5/8"	2-9/16"		2,000	2,720	TWSD3	TWLC4	TWSD6	TWLC4
2"				2,200	2,992	TWSD3	TWLC4	TWSD6	TWLC8
	1-3/4"	2-3/4"	1-5/8"	2,600	3,536	TWSD3	TWLC4	TWSD6	TWLC8
2-1/4"				3,000	4,080	TWSD3	TWLC4	TWSD6	TWLC8
	1-7/8"	2-15/16"	1-3/4"	3,700	5,032	TWSD6	TWLC4	TWSD11	TWLC8
2-1/2"	2"	3-1/8"		4,000	5,440	TWSD6	TWLC8	TWSD11	TWLC15
			1-7/8"	4,400	5,984	TWSD6	TWLC8	TWSD11	TWLC15
2-3/4"			2"	5,100	6,936	TWSD6	TWLC8	TWSD11	TWLC15
	2-1/4"	3-1/2"		6,000	8,160	TWSD6	TWLC8	TWSD25	TWLC15
3"		3-7/8"	2-1/4"	7,000	9,520	TWSD11	TWLC8	TWSD25	TWLC15
	2-1/2"			8,000	10,880	TWSD11	TWLC15	TWSD25	TWLC30
3-1/4"				9,000	12,240	TWSD11	TWLC15	TWSD25	TWLC30
3-1/2"	2-3/4"	4-1/4"	2-1/2"	10,000	13,600	TWSD11	TWLC15	TWSD25	TWLC30
				11,500	15,640	TWSD25	TWLC15	TWSD25	TWLC30
3-3/4"			2-3/4"	13,000	17,680	TWSD25	TWLC15	Please Inquire	TWLC30
4"				14,500	19,720	TWSD25	TWLC15	Please Inquire	
				15,500	21,080	TWSD25	TWLC30	Please Inquire	
4-1/4"	3-1/4"	5"	3"	16,500	22,440	TWSD25	TWLC30	Please Inquire	
				19,500	26,520	TWSD25	TWLC30	Please Inquire	
4-1/2"	3-1/2"	5-3/8"	3-1/4"	20,500	27,880	TWSD25	TWLC30		
				21,500	29,240	TWSD25	TWLC30	For	
				24,500	33,320	TWSD25	TWLC30	Higher	
4-3/4"	3-3/4"	5-3/4"	3-1/2"	25,500	34,680	Please Inquire	TWLC30	Torque	
6-1/2"	4-1/4"			29,500	40,120	Please Inquire	Please Inquire	Values	



LIFETIME MARATHON™ WARRANTY



POWER TEAM®

All Power Team products and parts, with the exception noted below, are warranted against defects in materials and workmanship for the life of the product or part. (The life of the product or part is defined as that point in time when it no longer functions due to normal wear.) This warranty does not cover any product or part that has been worn out, abused, heated, ground or otherwise altered, used for a purpose other than that for which it was intended or used in a manner inconsistent with any instructions regarding its use. Chains, batteries, electric motors, gas engines, knives and cutter blades which are sold with Power Team products are not covered by this warranty. All electric motors and gas engines are separately warranted by their manufacturer under the conditions stated in their separate warranty.

Power Team's electronic products are warranted against defects in material and workmanship for one year.

To qualify for warranty consideration, return the Power Team product, freight prepaid, to a Power Team authorized repair center or to the Power Team factory. If any product or part manufactured by Power Team is found to be defective by Power Team, in its sole judgement, Power Team will, at its option, either repair or replace such defective product or part and return it via best ground transportation, freight prepaid. THIS REMEDY SHALL BE THE EXCLUSIVE REMEDY AVAILABLE FOR ANY DEFECTS IN THE PRODUCTS OR PARTS MANUFACTURED AND SOLD BY POWER TEAM OR FOR DAMAGES RESULTING FROM ANY OTHER CAUSE WHATSOEVER, INCLUDING WITHOUT LIMITATION, POWER TEAM'S NEGLIGENCE. POWER TEAM SHALL NOT, IN ANY EVENT, BE LIABLE TO ANY BUYER FOR CONSEQUENTIAL OR INCIDENTAL DAMAGES OF ANY KIND, WHETHER FOR DEFECTIVE OR NON-CONFORMING GOODS, NEGLIGENCE, ON THE BASIS OF STRICT LIABILITY OR FOR ANY OTHER REASON.

Power Team's warranty is expressly limited to persons who purchase Power Team's products or parts for the resale or use in the ordinary course of the buyer's business.

THIS WARRANTY IS EXCLUSIVE, AND POWER TEAM MAKES NO OTHER WARRANTY OF ANY KIND WHATSOEVER, EXPRESSED OR IMPLIED, WITH RESPECT TO THE PRODUCTS MANUFACTURED AND SOLD BY IT, WHETHER AS TO MERCHANTABILITY, FITNESS FOR A PARTICULAR PURPOSE, OR ANY OTHER MATTER. No agent, employee or representative of Power Team has any authority to bind Power Team to any affirmation, representation or warranty concerning Power Team products or parts, except as stated herein.

The purpose of this exclusive remedy shall be to provide the buyer with repair or replacement of products or parts manufactured by Power Team found to be defective in materials or workmanship or negligently manufactured. This exclusive remedy shall not be deemed to have failed of its essential purpose so long as Power Team is willing and able to replace said defective products or parts in the prescribed manner.



Every effort has been made to assure the accuracy of product descriptions in this catalog at the time of printing. SPX Hydraulic Technologies reserves the right to modify or discontinue products without prior notice.

Power Team University



Proper training is needed to operate and maintain hydraulic equipment with safety and efficiency. Power Team offers a range of classes to help you safely operate and maintain your tools.

Safety Training

Workplace safety should be a high priority to assure high pressure hydraulic tools are used in accordance with recommended safety procedures. Power Team Safety Training Seminars demonstrate the proper methods for operating high pressure hydraulic tools to avoid equipment damage and lost time accidents. Safety seminars can be conducted at a customer facility, job site or Power Team headquarters.

Maintenance & Repair Training

Maintaining Power Team products in good operating condition enhances operating efficiency and extends service life. This seminar explains the proper methods for keeping Power Team products operating at peak levels of performance and reliability. Topics include understanding hydraulic circuits, product maintenance, troubleshooting, and field repairs. Three and five day seminars are structured to meet your product knowledge requirements.

Class schedules are posted on powerteam.com. Contact your district sales manager for more details or call **800-477-8326**.

SPX[®]

HYDRAULIC TECHNOLOGIES

6-39



CYLINDERS

**World Headquarters
The Americas
Customer Service Center**

5885 11th Street
Rockford, Illinois 61109
Tel: 815-874-5556

**European
Customer Service Center**

Albert Thijsstraat 12
6471 WX Eygelshoven
The Netherlands
Tel: 31 (45) 5678877
Fax: 31 (45) 5678878
infoeurope@powerteam.com

**Asia Pacific
Customer Service Center**

7 Gul Circle
Singapore 629563
Singapore
Tel: (65) 6265 3343
Fax: (65) 6265 6646
infoasia@powerteam.com

**China
Customer Service Center**

No. 1568 Hua Shan Road
Treasury Building
11th Floor
Shanghai 200052, China
Tel: 86 (21) 2208.5888
Fax: 86 (21) 2208.5682
infochina@powerteam.com

40-103



PUMPS

Customer Service/
Order Entry
Tel: 800.541.1418
Fax: 800.288.7031

104-133



ACCESSORIES

Technical Services
Tel: 800.477.8326
Fax: 800.765.8326
info@powerteam.com

134-147



SHOP EQUIP

148-163



JACKS

164-189



TOOLS

190-226



PULLERS

227-233



RESOURCES

POWERTEAM.COM

Distributed by:

